

High Luminous Efficacy
Red LED Emitter
LZ4-00R110



Key Features

- High Luminous Efficacy 10W Red LED
- Ultra-small foot print – 7.0mm x 7.0mm x 4.1mm
- Surface mount ceramic package with integrated glass lens
- Very low Thermal Resistance (3°C/W)
- Individually addressable die
- Very high Luminous Flux density
- New industry standard for Lumen Maintenance (>90% at 100,000 Hours)
- JEDEC Level 2 for Moisture Sensitivity Level
- Autoclave compliant (JEDEC JESD22-A102-C)
- Lead (Pb) free and RoHS compliant
- Reflow solderable (up to 6 cycles)
- Emitter available on [Standard MCPCB](#) (optional)

Typical Applications

- Emergency lighting
- Architectural Lighting
- Automotive and Marine lighting
- Airfield lighting and signs
- Buoys
- Beacons
- Machine vision

Description

The LZ4-00R110 Red LED emitter provides 10W power in an extremely small package. With a 7.0mm x 7.0mm x 4.1mm ultra-small footprint, this package provides exceptional luminous flux density. LedEngin's LZ4-00R110 LED offers ultimate design flexibility with individually addressable die. The patent-pending design has unparalleled thermal and optical performance. The high quality materials used in the package are chosen to optimize light output and minimize stresses which results in monumental reliability and lumen maintenance. The robust product design thrives in outdoor applications with high ambient temperatures and high humidity.

Table of Contents

Product Nomenclature	3
IPC/JEDEC Moisture Sensitivity	3
Average Lumen Maintenance Projections	3
Luminous Flux Binning.	4
Dominant Wavelength Binning	4
Forward Voltage Binning	4
Absolute Maximum Ratings	5
Optical Characteristics	5
Electrical Characteristics	5
Mechanical Dimensions	6
Pin-Out	6
Recommended Solder Pad Layout	6
Reflow Soldering Profile	7
Typical Radiation Pattern	7
Typical Relative Spectral Power Distribution	8
Typical Dominant Wavelength Shift over Temperature	8
Typical Relative Light Output	9
Typical Relative Light Output over Temperature	9
Typical Forward Current Characteristics	10
Current Derating Curves	10
Emitter Tape & Reel Specifications	11
Company Information	12

Product Nomenclature

The LZ Series part number designation is defined as follows:



Where:

- A – designates the number of LED die in the package (“4” for 10W)
- B – designates the package level (“0” for Emitter)
- C – designates the radiation pattern (“0” for Lambertian)
- D and E – designate the color (“R1” for Red – 627nm Dominant Wavelength)
- F and G – designate the Power (“10” for 10W typical rating)
- H – designates the Flux bin (See Table 2)
- J and K – designate the Dominant Wavelength bin (see Table 3)
- L – designates the V_F bin (See Table 4)

Ordering information:

For ordering LedEngin products, please reference the base part number. The base part number represents any of the flux, dominant wavelength, or forward voltage bins specified in the binning tables below. For ordering products with special bin selections, please contact a LedEngin sales representative or authorized distributor.

IPC/JEDEC Moisture Sensitivity Level

Table 1 - IPC/JEDEC J-STD-20 MSL Classification:

Level	Floor Life		Soak Requirements			
	Time	Conditions	Standard	Accelerated	Standard	Accelerated
	Time	Conditions	Time (hrs)	Conditions	Time (hrs)	Conditions
2	1 Year	≤ 30°C/ 60% RH	168 +5/-0	30°C/ 60% RH	n/a	n/a

Notes for Table 1:

1. The standard soak time is the sum of the default value of 24 hours for the semiconductor manufacturer’s exposure time (MET) between bake and bag and the floor life of maximum time allowed out of the bag at the end user of distributor’s facility.

Average Lumen Maintenance Projections

Lumen maintenance generally describes the ability of a lamp to retain its output over time. The useful lifetime for solid state lighting devices (Power LEDs) is also defined as Lumen Maintenance, with the percentage of the original light output remaining at a defined time period.

Based on long-term WHTOL testing, LedEngin projects that the LZ Series will deliver, on average, 90% Lumen Maintenance at 100,000 hours of operation at a forward current of 700 mA per die. This projection is based on constant current operation with junction temperature maintained at or below 110°C.

Luminous Flux Bins

Table 2:

Bin Code	Minimum Luminous Flux (Φ_V) @ $I_F = 700\text{mA}$ ^[1,2] (lm)	Maximum Luminous Flux (Φ_V) @ $I_F = 700\text{mA}$ ^[1,2] (lm)	Typical Luminous Flux (Φ_V) @ $I_F = 1000\text{mA}$ ^[2] (lm)
Q	228	285	301
R	285	356	388
S	356	445	485

Notes for Table 2:

1. Luminous flux performance guaranteed within published operating conditions. LedEngin maintains a tolerance of $\pm 10\%$ on flux measurements.
2. Future products will have even higher levels of luminous flux performance. Contact LedEngin Sales for updated information.

Dominant Wavelength Bins

Table 3:

Bin Code	Minimum Dominant Wavelength (λ_D) @ $I_F = 700\text{mA}$ ^[1,2] (nm)	Maximum Dominant Wavelength (λ_D) @ $I_F = 700\text{mA}$ ^[1,2] (nm)
R2	620	630
R4	630	640
R6	640	650

Notes for Table 3:

1. Dominant wavelength is derived from the CIE 1931 Chromaticity Diagram and represents the perceived hue.
2. LedEngin maintains a tolerance of $\pm 0.5\text{nm}$ on dominant wavelength measurements.

Forward Voltage Bins

Table 4:

Bin Code	Minimum Forward Voltage (V_F) @ $I_F = 700\text{mA}$ ^[1,2] (V)	Maximum Forward Voltage (V_F) @ $I_F = 700\text{mA}$ ^[1,2] (V)
B	8.96	9.92
C	9.92	10.88
D	10.88	11.84
E	11.84	12.80

Notes for Table 4:

1. LedEngin maintains a tolerance of $\pm 0.04\text{V}$ for forward voltage measurements.
2. Forward Voltage is binned with all four LED dice connected in series.

Absolute Maximum Ratings

Table 5:

Parameter	Symbol	Value	Unit
DC Forward Current ^[1]	I_F	1000	mA
Peak Pulsed Forward Current ^[2]	I_{FP}	1500	mA
Reverse Voltage	V_R	See Note 3	V
Storage Temperature	T_{stg}	-40 ~ +125	°C
Junction Temperature	T_J	125	°C
Soldering Temperature ^[4]	T_{sol}	260	°C
Allowable Reflow Cycles		6	
Autoclave Conditions ^[5]		121°C at 2 ATM, 100% RH for 168 hours	
ESD Sensitivity ^[6]		> 8,000 V HBM Class 3B JESD22-A114-D	

Notes for Table 5:

- Maximum DC forward current (per die) is determined by the overall thermal resistance and ambient temperature. Follow the curves in Figure 10 for current derating.
- Pulse forward current conditions: Pulse Width \leq 10msec and Duty Cycle \leq 10%.
- LEDs are not designed to be reverse biased.
- Solder conditions per JEDEC 020c. See Reflow Soldering Profile Figure 3.
- Autoclave Conditions per JEDEC JESD22-A102-C.
- LedEngin recommends taking reasonable precautions towards possible ESD damages and handling the LZ4-00R110 in an electrostatic protected area (EPA). An EPA may be adequately protected by ESD controls as outlined in ANSI/ESD S6.1.

Optical Characteristics @ $T_C = 25^\circ\text{C}$

Table 6:

Parameter	Symbol	Typical	Unit
Luminous Flux (@ $I_F = 700\text{mA}$) ^[1]	Φ_V	260	lm
Luminous Flux (@ $I_F = 1000\text{mA}$) ^[1]	Φ_V	317	lm
Dominant Wavelength	λ_D	627	nm
Viewing Angle ^[2]	$2\Theta_{1/2}$	90	Degrees
Total Included Angle ^[3]	$\Theta_{0.9V}$	100	Degrees

Notes for Table 6:

- Luminous flux typical value is for all four LED dice operating concurrently at rated current.
- Viewing Angle is the off axis angle from emitter centerline where the luminous intensity is $\frac{1}{2}$ of the peak value.
- Total Included Angle is the total angle that includes 90% of the total luminous flux.

Electrical Characteristics @ $T_C = 25^\circ\text{C}$

Table 7:

Parameter	Symbol	Typical	Unit
Forward Voltage (@ $I_F = 700\text{mA}$) ^[1]	V_F	9.4	V
Forward Voltage (@ $I_F = 1000\text{mA}$) ^[1]	V_F	10.0	V
Temperature Coefficient of Forward Voltage ^[1]	$\Delta V_F / \Delta T_J$	-6.5	mV/°C
Thermal Resistance (Junction to Case)	$R\Theta_{J-C}$	3	°C/W

Notes for Table 7:

- Forward Voltage typical value is for all four LED dice connected in series.

Mechanical Dimensions (mm)

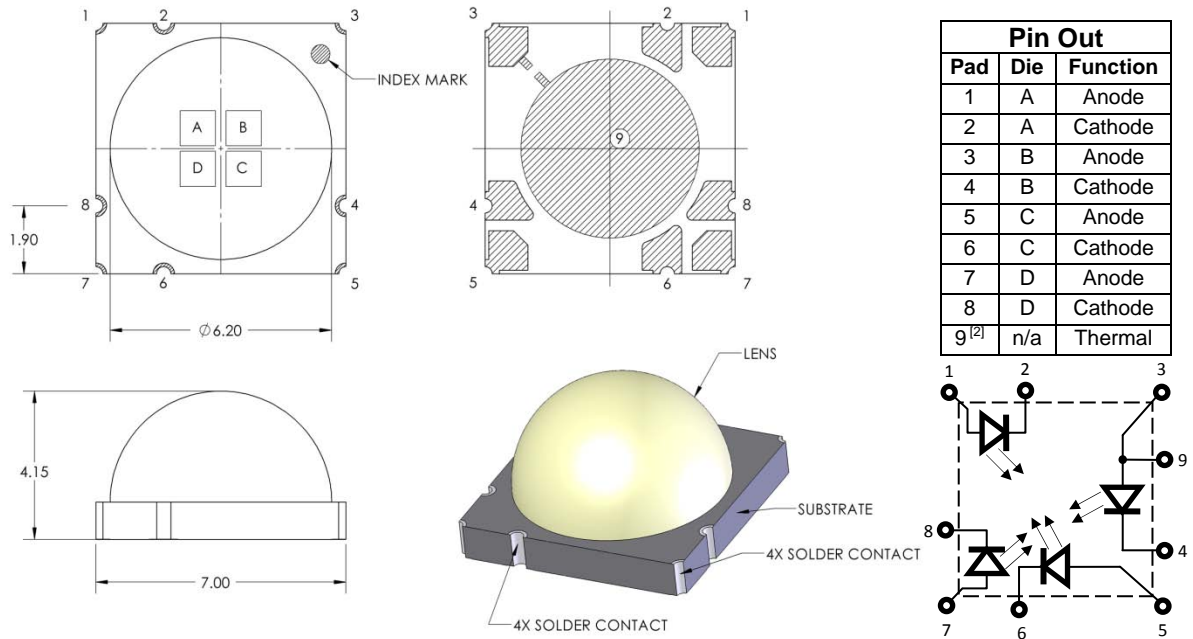

Figure 1: Package outline drawing.

Notes for Figure 1:

1. Unless otherwise noted, the tolerance = ± 0.20 mm.
2. Thermal contact, Pad 9, is electrically connected to Pad 3. Do not connect any pad to the thermal contact, Pad 9. When mounting the LZ4-00R110 onto a MCPCB, by default its dielectric layer provides for the necessary electrical insulation in between all contact pads. LedEngin offers a [LZ4-20R110](#) MCPCB option which provides for electrical insulation between all contact pads. Please refer to Application Note MCPCB Option 2, or contact a LedEngin sales representative for more information.

Recommended Solder Pad Layout (mm)

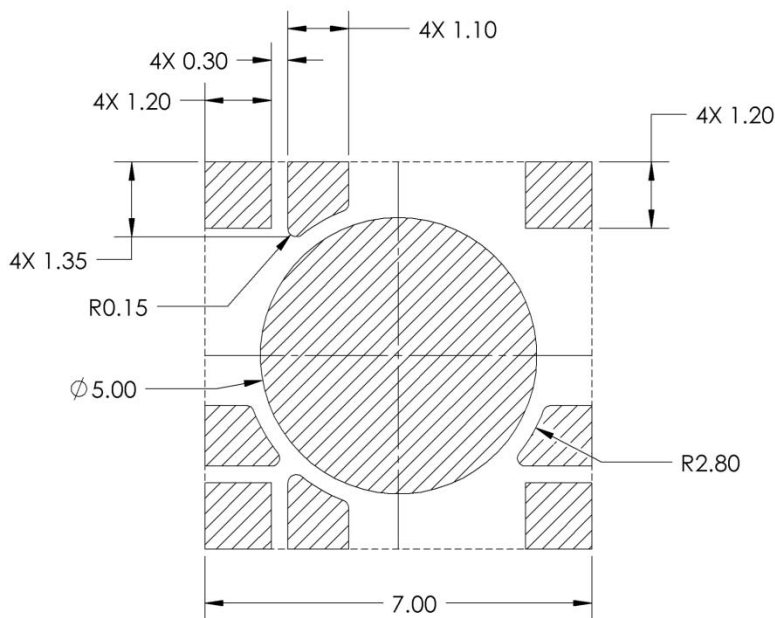

Figure 2: Recommended solder mask opening (hatched area) for anode, cathode, and thermal pad.

Note for Figure 2:

1. Unless otherwise noted, the tolerance = ± 0.20 mm.

Reflow Soldering Profile

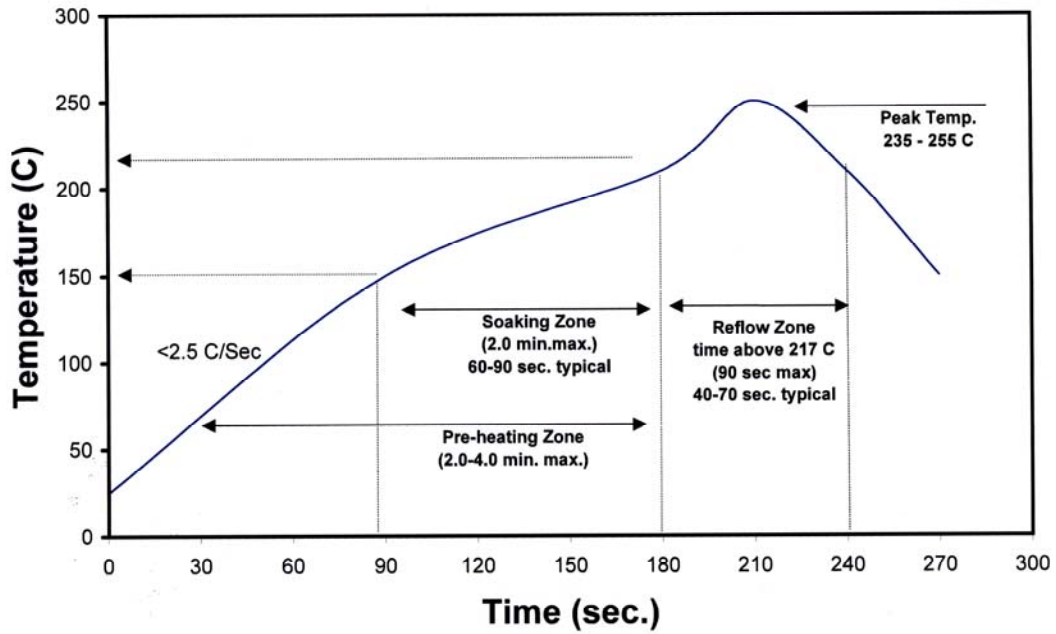

Figure 3: Reflow soldering profile for lead free soldering.

Typical Radiation Pattern

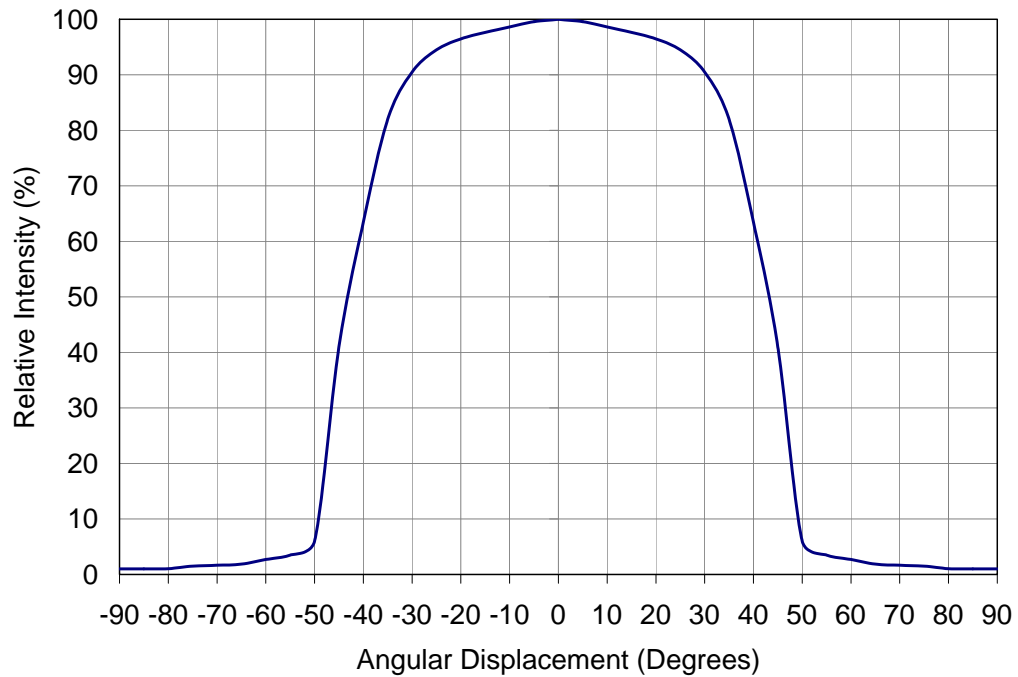

Figure 4: Typical representative spatial radiation pattern.

Typical Relative Spectral Power Distribution

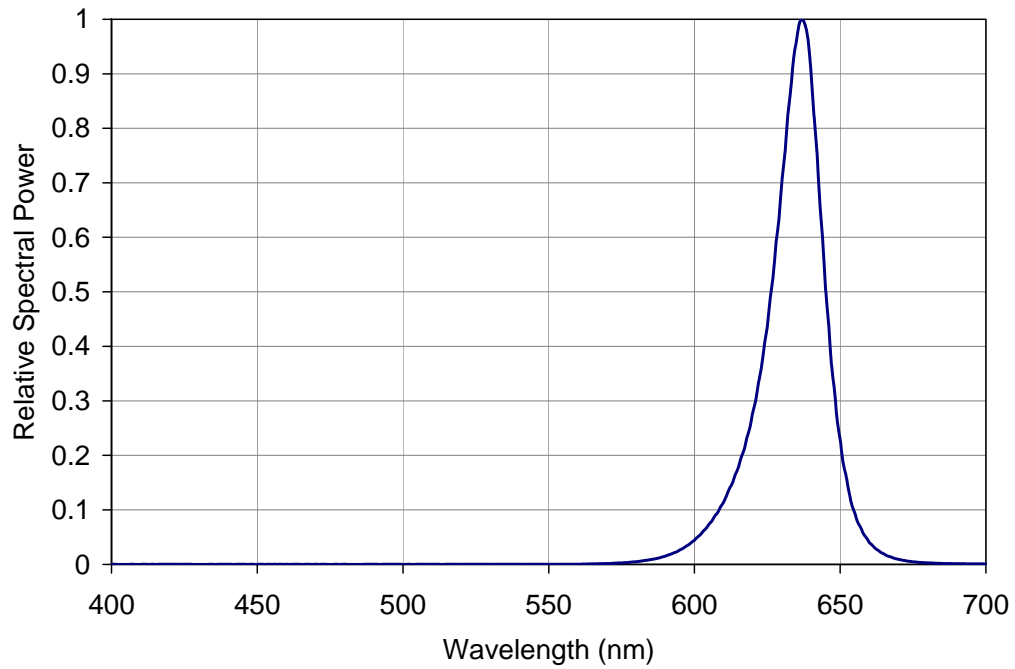

Figure 5: Relative spectral power vs. wavelength @ $T_c = 25^\circ\text{C}$.

Typical Dominant Wavelength Shift over Temperature

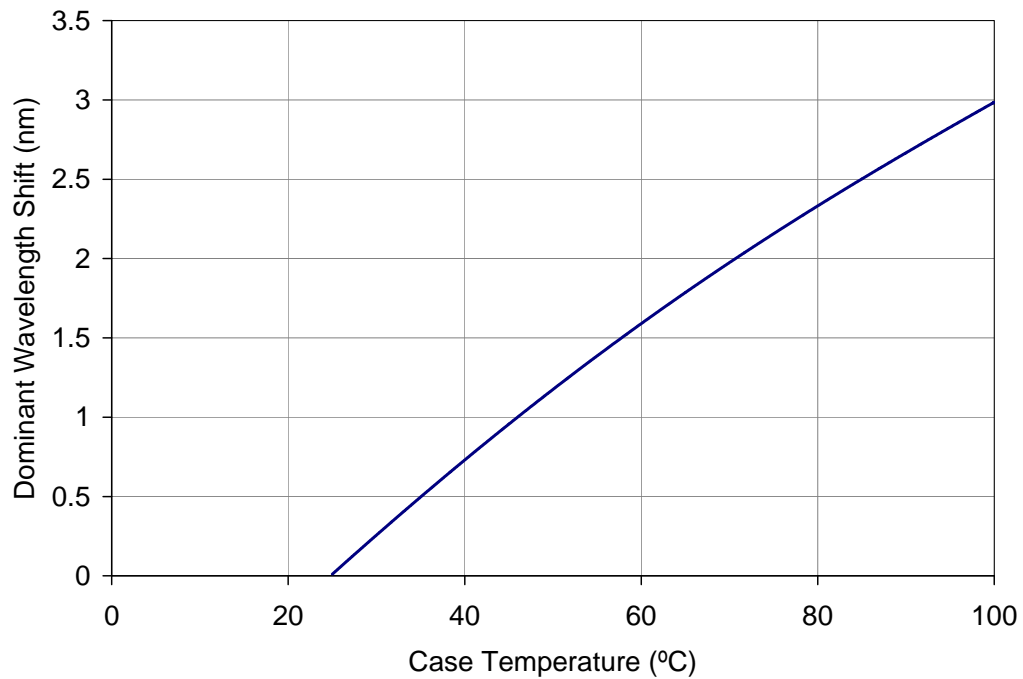

Figure 6: Typical dominant wavelength shift vs. case temperature.

Typical Relative Light Output

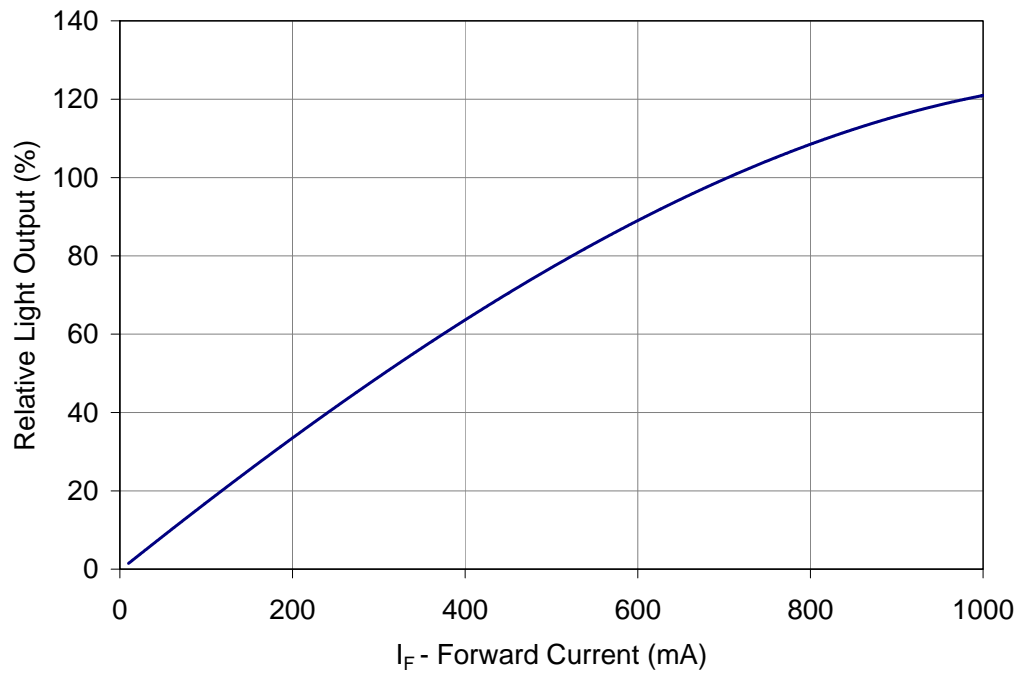

Figure 7: Typical relative light output vs. forward current @ T_C = 25°C.

Typical Relative Light Output over Temperature

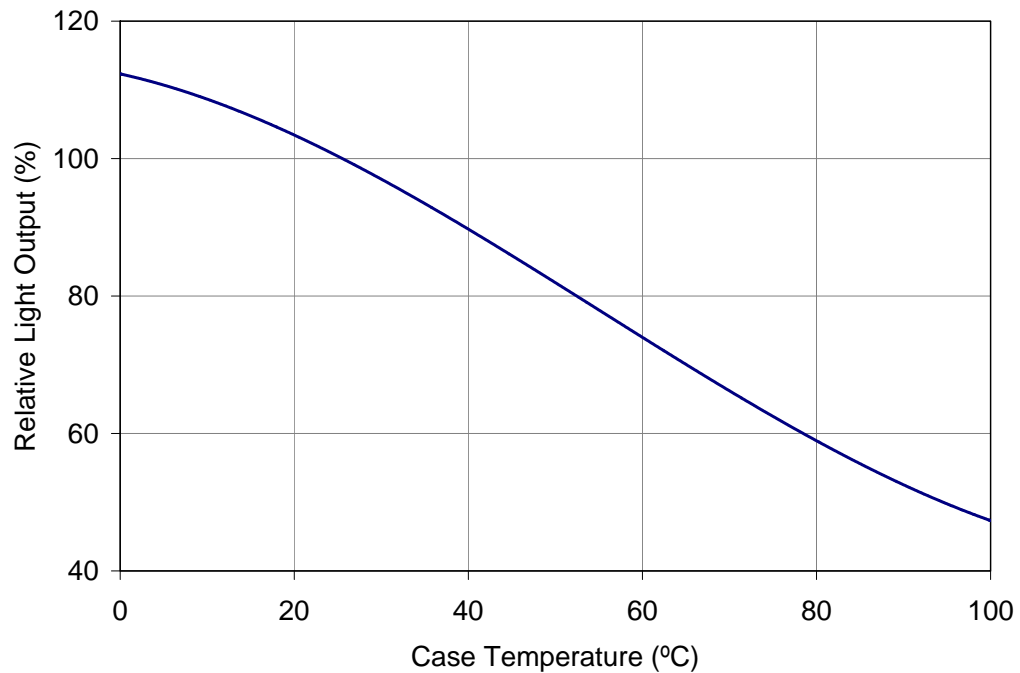

Figure 8: Typical relative light output vs. case temperature.

Typical Forward Current Characteristics

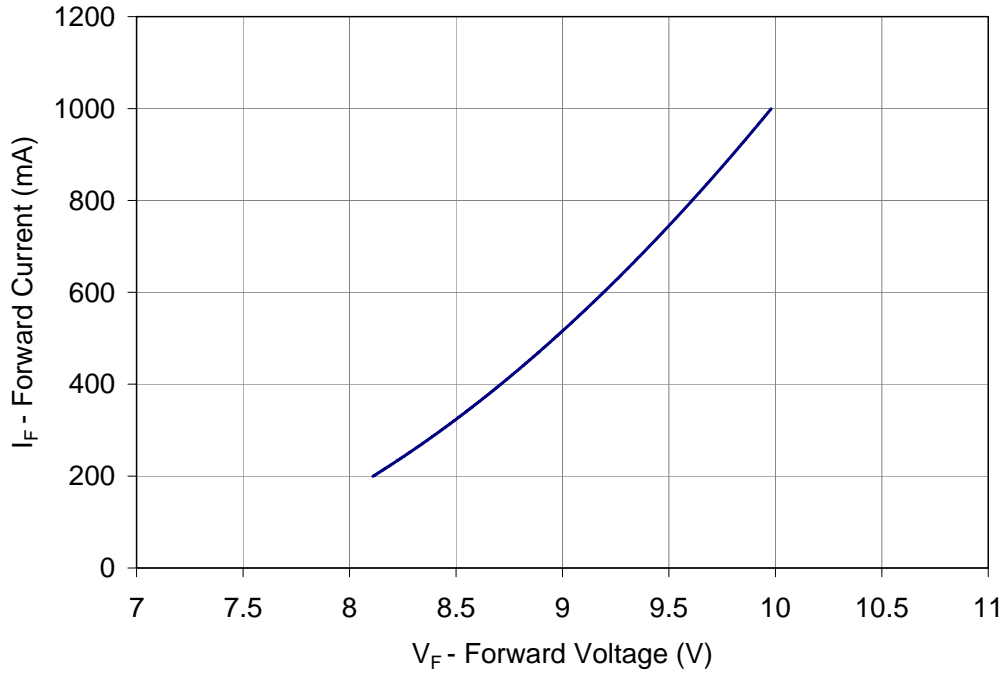

Figure 9: Typical forward current vs. forward voltage @ T_C = 25°C.

Note for Figure 9:

1. Forward Voltage curve assumes that all four LED dice are connected in series.

Current Derating

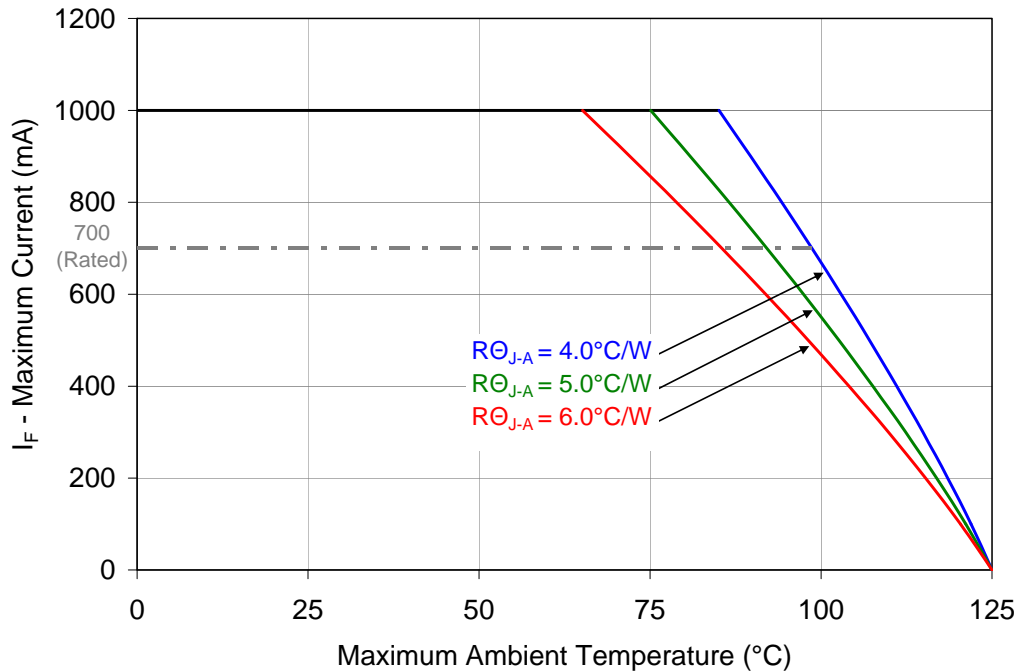

Figure 10: Maximum forward current vs. ambient temperature based on T_{J(MAX)} = 125°C.

Notes for Figure 10:

1. Maximum current assumes that all four LED dice are operating concurrently at the same current.
2. R_{Θ_{J-C}} [Junction to Case Thermal Resistance] for the LZ4-00R110 is typically 3.0°C/W.
3. R_{Θ_{J-A}} [Junction to Ambient Thermal Resistance] = R_{Θ_{J-C}} + R_{Θ_{C-A}} [Case to Ambient Thermal Resistance].

Emitter Tape and Reel Specifications (mm)

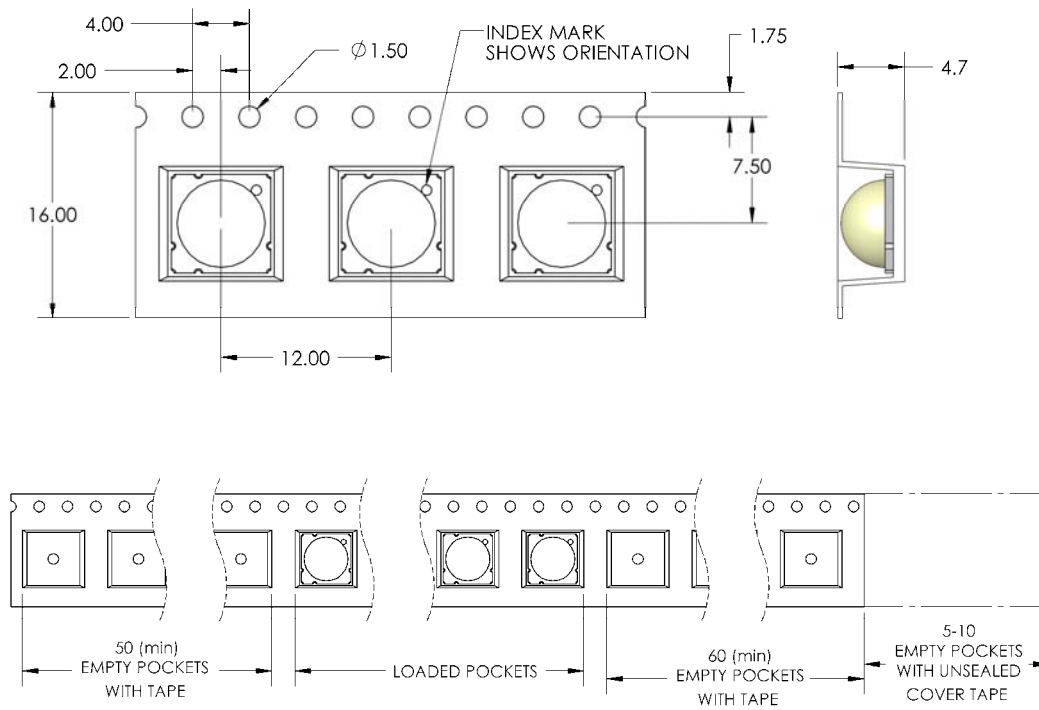

Figure 11: Emitter carrier tape specifications (mm).

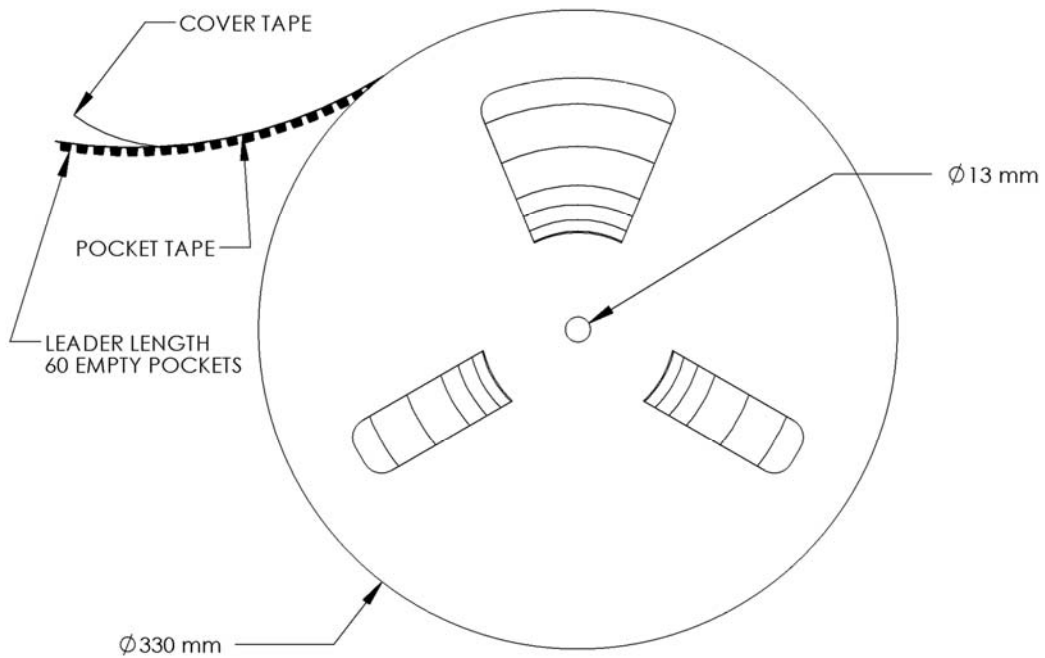

Figure 12: Emitter Reel specifications (mm).

Company Information

The LZ4-00R110 Red LED emitter is developed, manufactured, and marketed by LedEngin, Inc., located in Santa Clara, CA. LedEngin is a global market leader in advanced high-power LED emitters and light-source modules. LedEngin provides total solutions from 3W to 15W in single packages with ultra-small footprints in all colors from White, Dental Blue, Blue, Green, Red, RGB, and UV. LedEngin supports customers to generate solid-state lighting designs that conserve natural resources. LedEngin is focused on differentiated Ultra High-Brightness LED solutions for diverse global markets using its patent-pending package designs and manufacturing processes. LedEngin offers catalog as well as full custom solutions to enable flexible system designs for its customers. LedEngin is dedicated to long-term win-win partnering with its customers and suppliers.

LedEngin reserves the right to make changes to improve performance without notice.

Please contact Sales@ledengin.com for more information.