

32-bit Microcontrollers

CMOS

FR80 MB91660 Series

MB91661/F662/664/V650

■ DESCRIPTION

The MB91660 series is a line of Fujitsu microcontrollers based on a 32-bit RISC CPU core that feature a variety of peripheral functions for embedded applications that demand high-performance and high-speed CPU processing.

This series is based on the FR80* family CPU and is implemented as a single chip.

* : FR, the abbreviation of FUJITSU RISC controller, is a line of products of Fujitsu Microelectronics Limited.

■ FEATURES

- FR80 CPU
 - 32-bit RISC, load/store architecture, five-stage pipeline
 - General-purpose registers : 32-bit × 16
 - 16-bit fixed-length instructions (basic instructions) : 1 instruction per cycle
 - Instructions suitable for embedded applications
 - Memory-to-memory transfer, bit processing, barrel shift instructions, etc.
 - Instruction support for high level languages
 - Function entry and exit instructions, instructions for register multi-load and multi-store
 - Bit search instruction
 - "1" detection, "0" detection, transition point detection
 - Branch instructions with delay slots
 - Reduced overhead when processing branches
 - Register interlock functions
 - Facilitate coding in assembly language
 - Built-in multiplier/instruction-level support
 - Signed 32-bit multiplication : 5 cycles
 - Signed 16-bit multiplication : 3 cycles
 - Interrupts (save PC and PS) : 6 cycles, 16 priority levels
 - Harvard architecture allowing program access and data access to be executed simultaneously
 - The prefetch function for instructions using the 4-word instruction queue in the CPU

(Continued)

For the information for microcontroller supports, see the following web site.

This web site includes the "**Customer Design Review Supplement**" which provides the latest cautions on system development and the minimal requirements to be checked to prevent problems before the system development.

<http://edevic.fujitsu.com/micom/en-support/>

MB91660 Series

- Instruction compatible with FR family CPU
 - Additional bit search instructions
 - No resource instructions and coprocessor instructions
- Maximum operating frequency
 - CPU : 33 MHz
 - Resources : 33 MHz
 - External bus : 33 MHz
- External bus interface
 - Operating frequency : Max 33 MHz
 - 24 address lines, 8- or 16-bit data I/O (separate busses or multiplexed bus)
 - Chip select output available for 4 independent programmable areas
 - Programmable automatic wait cycle insertion for each area
- DMA controller (DMAC)
 - 8 channels
 - Address space : 32 bits (4 Gbytes)
 - Transfer modes : Block transfer/burst transfer/demand transfer
 - Address update : Increment/decrement/fixed (increment/decrement step size of 1, 2, or 4)
 - Transfer data length : Selectable from 8-bit, 16-bit, 32-bit
 - Block size : 1 to 16
 - Number of transfers : 1 to 65535
 - Transfer requests
 - Requests from software
 - Interrupt requests from peripheral resources (interrupt requests are shared, including external interrupts)
 - Requests from external pins
 - Reload functions : Reload can be specified on all channels
 - Priority order : Fixed (ch.0 > ch.1 > ch.2 > ch.3 > ...) or round-robin
 - Interrupt requests : Interrupts can be generated for transfer complete, transfer error, and transfer interrupted.
- Multifunction serial interface
 - 4 channels with 16-byte FIFO, 8 channels without FIFO
 - Operation mode is selectable from UART/CSIO/I²C for each channel (For ch.0, I²C is not available.)
 - UART
 - Full-duplex double buffer
 - Selectable parity on/off
 - Built-in dedicated baud rate generator
 - External clock can be used as a serial clock
 - Error detection function for parity, frame and overrun errors
 - CSIO
 - Full-duplex double buffer
 - Built-in dedicated baud rate generator
 - Overrun error detection function
 - I²C
 - Supports both standard mode (Max 100 kbps) and Fast mode (Max 400 kbps)
 - Some channels are 5 V tolerant

(Continued)

- Interrupts
 - Total of 32 external interrupts (some pins are 5 V tolerant)
 - Interrupts from peripheral resources
 - Programmable interrupt levels (16 levels)
 - Can be used to return from stop mode, sleep mode
- A/D converter
 - 24 channels, 1 unit
 - 10-bit resolution
 - Conversion time : approx. 1.2 μ s (PCLK = 33 MHz)
 - Priority conversion (2 levels)
 - Conversion modes : Single-shot conversion mode, scan conversion mode
 - Activation sources : Software, external trigger, base timer
 - Built-in FIFO for storing conversion data (for scan conversion:16, for priority conversion:4)
- D/A converter
 - 3 channels
 - 8-bit resolution
- Base timer
 - 16 channels
 - Operation mode is selectable from the followings for each channel
 - 16/32-bit reload timer
 - 16-bit PWM timer
 - 16/32-bit PWC timer
 - 16-bit PPG timer
 - Cascading connection between 2 channels allows them to be used as one 32-bit timer
 - Multiple channels can be started simultaneously
 - Input/output select function
- 16-bit reload timer
 - 3 channels (including 1 channel for REALOS)
 - Interval timer function
 - Count clock select function (peripheral clock (PCLK) divided by 2 to 64)
- Compare timer
 - 32-bit input capture : 8 channels
 - 32-bit output compare : 8 channels
 - 32-bit free-run timer : 2 channels
- Other interval timers
 - Up/down counter : 4 channels
 - Watch counter : 1 channel
 - Watchdog timer : 1 channel

(Continued)

- USB function / HOST
 - 1 channel
 - Supports Full-Speed only
 - The USB function and USB HOST are the switch types (USB I/O multiplexed)
 - Support of DMA transfer

[USB Function]

 - Support of up to six endpoints
 - Endpoint 0 is provided for the fixed use of control transfers
 - Bulk or interrupt transfer can be selected for endpoint 1 to 5
 - Double buffer structure for endpoint 1 to 5

[USB HOST]

 - Support control transfer, bulk transfer, interrupt transfer, and isochronous transfer
 - Automatic detection of connection/disconnection of USB devices
 - Automatic processing of a handshake packet for IN/OUT token processing
 - Support of a maximum packet length of up to 256 bytes
 - Support for a wakeup function
- Slave interface
 - Equipped with a register for communication along with large-capacity transmission/ reception FIFO that enables large amount of data transmission and reception.
 - Buffer: reception 1.5 Kbytes, transmission 1.5 Kbytes
 - Host function: A function to process by storing to a buffer. Once the buffer is full, this function stops data reception.
Communication control is possible during data transmission/ reception. This enables CPU load reduction and efficiency of communication.
 - 16-bit data port
 - Transmission/ reception data port control function
- Main timer
 - 1 channel
 - Counts the oscillation stabilization wait time of the main clock (MCLK)
 - Counts the oscillation stabilization wait time of the PLL clock (PLLCLK)
 - Can be used as an interval timer while the main clock (MCLK) oscillations is stable
- Sub timer
 - 1 channel
 - Counts the oscillation stabilization wait time of the sub clock (SBCLK)
 - Can be used as an interval timer while the sub clock (SBCLK) oscillations is stable
- Clock generation
 - Main clock (MCLK) oscillator
 - Sub clock (SBCLK) oscillator
 - PLL clock (PLLCLK) oscillator
- Low-power dissipation mode
 - Stop mode
 - Watch mode
 - Sleep mode
 - Doze mode
 - Clock division function

(Continued)

(Continued)

- Other features
 - I/O port
 - INIT pin is provided as a reset pin
 - Watchdog timer reset, software reset
 - Delay interrupt
 - Power supply
 - Single power supply (When USB not used: 2.7 V to 3.6 V, When USB used: 3.0 V to 3.6 V)

MB91660 Series

■ PRODUCT LINEUP

Part number Parameter	MB91V650	MB91F662	MB91661	MB91664
Product type	Evaluation product	Flash memory product	MASK ROM product	
Built-in program memory capacity	— (Support by emulation memory)	512 Kbytes (Flash)	384 Kbytes (ROM)	128 Kbytes (ROM)
Built-in RAM capacity	128 Kbytes	48 Kbytes	32 Kbytes	16 Kbytes
External bus interface	Yes			
DMA controller (DMAC)	8 channels			
Base timer	16 channels			
Multifunction serial interface	Without FIFO : 8 channels (ch.0 to ch.7) With FIFO : 4 channels (ch.8 to ch.11)			
External interrupt	32 (some pins are 5 V tolerant)			
10-bit A/D converter	32 channels (2 units)	24 channels (1 unit)		
8-bit D/A converter	3 channels			
16-bit reload timer	3 channels			
Compare timer	32-bit input capture : 8 channels 32-bit output compare : 8 channels 32-bit free-run timer : 2 channels			
Up/Down counter	4 channels			
Watch counter	1 channel			
I/O port	154	99		
USB function / HOST	1 channel			
Slave interface	Yes			
Main timer	1 channel			
Sub timer	1 channel			
Wild register	16 channels			
Debug function	DSU4	—		

■ PACKAGES

Product name Package	MB91F662	MB91661	MB91664
FPT-120P-M21	○	○	○

○ : Supported

Note: Refer to "■ PACKAGE DIMENSIONS" for detailed information on each package.

PIN ASSIGNMENT

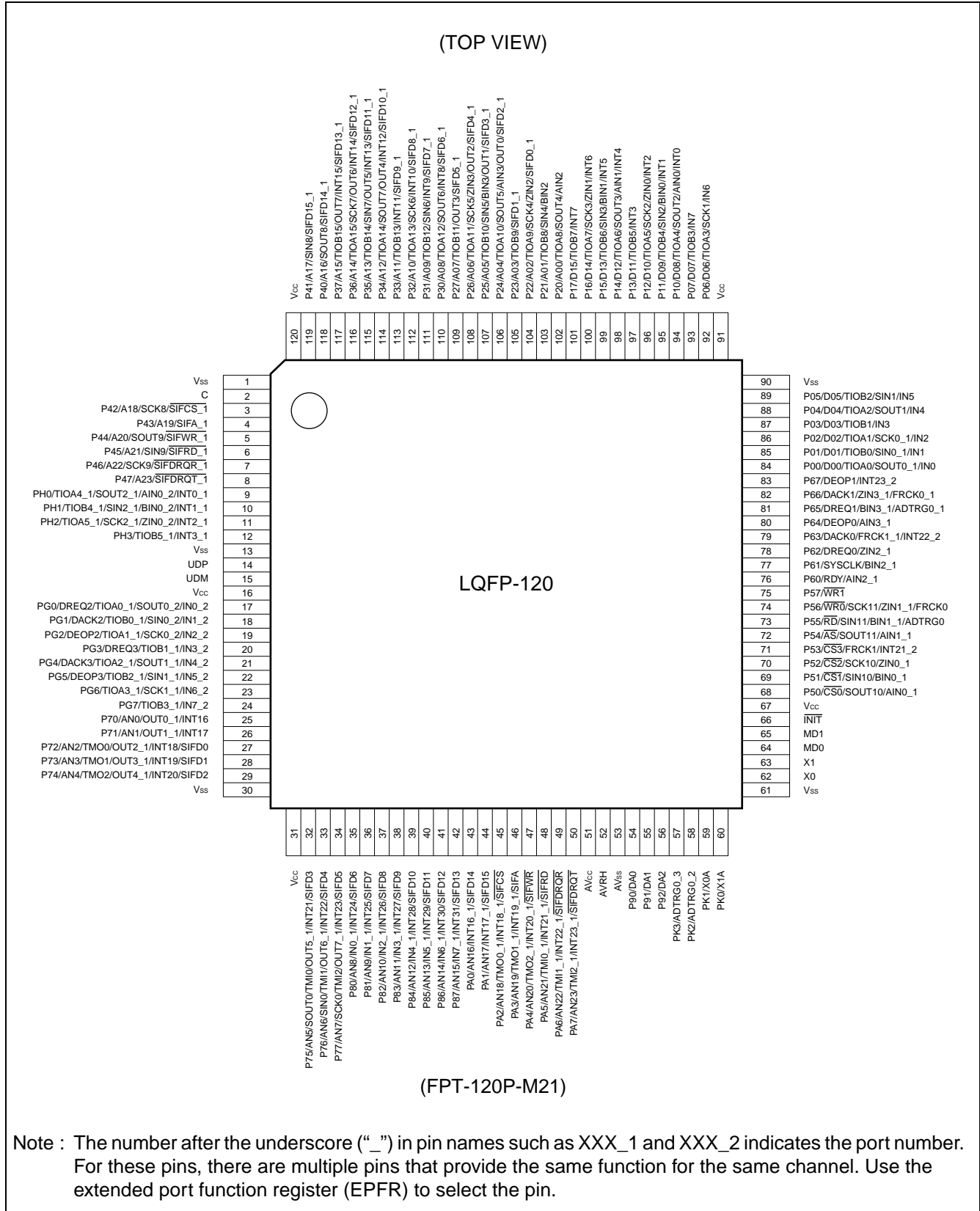

MB91660 Series

■ PIN DESCRIPTION

The number after the underscore (“_”) in pin names such as XXX_1 and XXX_2 indicates the port number. For these pins, there are multiple pins that provide the same function for the same channel. Use the extended port function register (EPFR) to select the pin.

Pin Number	Pin Name	I/O Circuit Type*1	Function	CMOS level input	CMOS level hysteresis input
1	V _{ss}	—	GND pin	—	—
2	C	—	Power stabilization capacity pin	—	—
3	P42	Q*2	General-purpose I/O port	—	○
	A18		External bus interface address bus bit18	—	—
	SCK8 (SCL8)		Multifunction serial interface ch.8 clock I/O pin. This pin operates as SCK8 when it is used in a UART/CSIO (operation modes 0 to 2) and as SCL8 when it is used in an I ² C (operation mode 4).	—	○
	SIFCS_1		Slave interface chip select signal input pin (Port 1)	○	—
4	P43	Q*2	General-purpose I/O port	—	○
	A19		External bus interface address bus bit19	—	—
	SIFA_1		Slave interface address signal input pin (Port 1)	○	—
5	P44	Q*2	General-purpose I/O port	—	○
	A20		External bus interface address bus bit20	—	—
	SOUT9 (SDA9)		Multifunction serial interface ch.9 output pin. This pin operates as SOUT9 when it is used in a UART/CSIO (operation modes 0 to 2) and as SDA9 when it is used in an I ² C (operation mode 4).	—	○
	SIFWR_1		Slave interface write strobe signal input pin (Port 1)	○	—
6	P45	Q*2	General-purpose I/O port	—	○
	A21		External bus interface address bus bit21	—	—
	SIN9		Multifunction serial interface ch.9 input pin	—	○
	SIFRD_1		Slave interface read strobe signal input pin (Port 1)	○	—
7	P46	D*2	General-purpose I/O port	—	○
	A22		External bus interface address bus bit22	—	—
	SCK9 (SCL9)		Multifunction serial interface ch.9 clock I/O pin. This pin operates as SCK9 when it is used in a UART/CSIO (operation modes 0 to 2) and as SCL9 when it is used in an I ² C (operation mode 4).	—	○
	SIFDRQR_1		Slave interface received data request signal output pin (Port 1)	—	—
8	P47	D*2	General-purpose I/O port	—	○
	A23		External bus interface address bus bit23	—	—
	SIFDRQT_1		Slave interface transmitted data request signal output pin (Port 1)	—	—

(Continued)

MB91660 Series

Pin Number	Pin Name	I/O Circuit Type*1	Function	CMOS level input	CMOS level hysteresis input
9	PH0	D*2	General-purpose I/O port	—	○
	TIOA4_1		Base timer ch.4 TIOA pin (Port 1)	—	—
	SOUT2_1 (SDA2_1)		Multifunction serial interface ch.2 output pin (Port 1). This pin operates as SOUT2_1 when it is used in a UART/CSIO (operation modes 0 to 2) and as SDA2_1 when it is used in an I ² C (operation mode 4).	—	○
	AIN0_2		Up/Down counter ch.0 AIN input pin (Port 2)	—	○
	INT0_1		External interrupt request 0 input pin (Port 1)	—	○
10	PH1	D*2	General-purpose I/O port	—	○
	TIOB4_1		Base timer ch.4 TIOB pin (Port 1)	—	○
	SIN2_1		Multifunction serial interface ch.2 input pin (Port 1)	—	○
	BIN0_2		Up/Down counter ch.0 BIN input pin (Port 2)	—	○
	INT1_1		External interrupt request 1 input pin (Port 1)	—	○
11	PH2	D*2	General-purpose I/O port	—	○
	TIOA5_1		Base timer ch.5 TIOA pin (Port 1)	—	○
	SCK2_1 (SCL2_1)		Multifunction serial interface ch.2 clock I/O pin (Port 1). This pin operates as SCK2_1 when it is used in a UART/CSIO (operation modes 0 to 2) and as SCL2_1 when it is used in an I ² C (operation mode 4).	—	○
	ZIN0_2		Up/Down counter ch.0 ZIN input pin (Port 2)	—	○
	INT2_1		External interrupt request 2 input pin (Port 1)	—	○
12	PH3	D*2	General-purpose I/O port	—	○
	TIOB5_1		Base timer ch.5 TIOB pin (Port 1)	—	○
	INT3_1		External interrupt request 3 input pin (Port 1)	—	○
13	V _{ss}	—	GND pin	—	—
14	UDP	USB	D+ pin of USB function / HOST	—	—
15	UDM	USB	D- pin of USB function / HOST	—	—
16	V _{cc}	—	Power pin	—	—
17	PG0	D*2	General-purpose I/O port	—	○
	DREQ2		DMA controller (DMAC) ch.2 transfer request input pin	—	○
	TIOA0_1		Base timer ch.0 TIOA pin (Port 1)	—	—
	SOUT0_2		Multifunction serial interface ch.0 output pin (Port 2). This pin operates as SOUT0_2 when it is used in a UART/CSIO (operation modes 0 to 2).	—	—
	IN0_2		32-bit input capture ch.0 input pin (Port 2)	—	○

(Continued)

MB91660 Series

Pin Number	Pin Name	I/O Circuit Type*1	Function	CMOS level input	CMOS level hysteresis input
18	PG1	D*2	General-purpose I/O port	—	○
	DACK2		DMA controller (DMAC) ch.2 transfer request acceptance signal output pin	—	—
	TIOB0_1		Base timer ch.0 TIOB pin (Port 1)	—	○
	SIN0_2		Multifunction serial interface ch.0 input pin (Port 2)	—	○
	IN1_2		32-bit input capture ch.1 input pin (Port 2)	—	○
19	PG2	D*2	General-purpose I/O port	—	○
	DEOP2		DMA controller (DMAC) ch.2 last transfer signal output pin	—	—
	TIOA1_1		Base timer ch.1 TIOA pin (Port 1)	—	○
	SCK0_2		Multifunction serial interface ch.0 clock I/O pin (Port 2). This pin operates as SCK0_2 when it is used in a UART/CSIO (operation modes 0 to 2).	—	○
	IN2_2		32-bit input capture ch.2 input pin (Port 2)	—	○
20	PG3	D*2	General-purpose I/O port	—	○
	DREQ3		DMA controller (DMAC) ch.3 transfer request input pin	—	○
	TIOB1_1		Base timer ch.1 TIOB pin (Port 1)	—	○
	IN3_2		32-bit input capture ch.3 input pin (Port 2)	—	○
21	PG4	D*2	General-purpose I/O port	—	○
	DACK3		DMA controller (DMAC) ch.3 transfer request acceptance signal output pin	—	—
	TIOA2_1		Base timer ch.2 TIOA pin (Port 1)	—	—
	SOUT1_1 (SDA1_1)		Multifunction serial interface ch.1 output pin (Port 1). This pin operates as SOUT1_1 when it is used in a UART/CSIO (operation modes 0 to 2) and as SDA1_1 when it is used in an I ² C (operation mode 4).	—	○
	IN4_2		32-bit input capture ch.4 input pin (Port 2)	—	○
22	PG5	D*2	General-purpose I/O port	—	○
	DEOP3		DMA controller (DMAC) ch.3 last transfer signal output pin	—	—
	TIOB2_1		Base timer ch.2 TIOB pin (Port 1)	—	○
	SIN1_1		Multifunction serial interface ch.1 input pin (Port 1)	—	○
	IN5_2		32-bit input capture ch.5 input pin (Port 2)	—	○
23	PG6	D*2	General-purpose I/O port	—	○
	TIOA3_1		Base timer ch.3 TIOA pin (Port 1)	—	○
	SCK1_1 (SCL1_1)		Multifunction serial interface ch.1 clock I/O pin (Port 1). This pin operates as SCK1_1 when it is used in a UART/CSIO (operation modes 0 to 2) and as SCL1_1 when it is used in an I ² C (operation mode 4).	—	○
	IN6_2		32-bit input capture ch.6 input pin (Port 2)	—	○

(Continued)

MB91660 Series

Pin Number	Pin Name	I/O Circuit Type*1	Function	CMOS level input	CMOS level hysteresis input
24	PG7	D*2	General-purpose I/O port	—	○
	TIOB3_1		Base timer ch.3 TIOB pin (Port 1)	—	○
	IN7_2		32-bit input capture ch.7 input pin (Port 2)	—	○
25	P70	E	General-purpose I/O port	—	○
	AN0		10-bit A/D converter ch.0 analog input pin	—	—
	OUT0_1		32-bit output compare ch.0 output pin (Port 1)	—	—
	INT16		External interrupt request 16 input pin	—	○
26	P71	E	General-purpose I/O port	—	○
	AN1		10-bit A/D converter ch.1 analog input pin	—	—
	OUT1_1		32-bit output compare ch.1 output pin (Port 1)	—	—
	INT17		External interrupt request 17 input pin	—	○
27	P72	R	General-purpose I/O port	—	○
	AN2		10-bit A/D converter ch.2 analog input pin	—	—
	TMO0		16-bit reload timer ch.0 output pin	—	—
	OUT2_1		32-bit output compare ch.2 output pin (Port 1)	—	—
	INT18		External interrupt request 18 input pin	—	○
	SIFD0		Slave interface data I/O pin bit0	○	—
28	P73	R	General-purpose I/O port	—	○
	AN3		10-bit A/D converter ch.3 analog input pin	—	—
	TMO1		16-bit reload timer ch.1 output pin	—	—
	OUT3_1		32-bit output compare ch.3 output pin (Port 1)	—	—
	INT19		External interrupt request 19 input pin	—	○
	SIFD1		Slave interface data I/O pin bit1	○	—
29	P74	R	General-purpose I/O port	—	○
	AN4		10-bit A/D converter ch.4 analog input pin	—	—
	TMO2		16-bit reload timer ch.2 output pin	—	—
	OUT4_1		32-bit output compare ch.4 output pin (Port 1)	—	—
	INT20		External interrupt request 20 input pin	—	○
	SIFD2		Slave interface data I/O pin bit2	○	—
30	V _{ss}	—	GND pin	—	—
31	V _{cc}	—	Power pin	—	—

(Continued)

MB91660 Series

Pin Number	Pin Name	I/O Circuit Type*1	Function	CMOS level input	CMOS level hysteresis input
32	P75	R	General-purpose I/O port	—	○
	AN5		10-bit A/D converter ch.5 analog input pin	—	—
	SOUT0		Multifunction serial interface ch.0 output pin. This pin operates as SOUT0 when it is used in a UART/CSIO (operation modes 0 to 2).	—	—
	TMI0		16-bit reload timer ch.0 input pin	—	○
	OUT5_1		32-bit output compare ch.5 output pin (Port 1)	—	—
	INT21		External interrupt request 21 input pin	—	○
	SIFD3		Slave interface data I/O pin bit3	○	—
33	P76	R	General-purpose I/O port	—	○
	AN6		10-bit A/D converter ch.6 analog input pin	—	—
	SIN0		Multifunction serial interface ch.0 input pin	—	○
	TMI1		16-bit reload timer ch.1 input pin	—	○
	OUT6_1		32-bit output compare ch.6 output pin (Port 1)	—	—
	INT22		External interrupt request 22 input pin	—	○
	SIFD4		Slave interface data I/O pin bit4	○	—
34	P77	R	General-purpose I/O port	—	○
	AN7		10-bit A/D converter ch.7 analog input pin	—	—
	SCK0		Multifunction serial interface ch.0 clock I/O pin This pin operates as SCK0 when it is used in a UART/CSIO (operation modes 0 to 2).	—	○
	TMI2		16-bit reload timer ch.2 input pin	—	○
	OUT7_1		32-bit output compare ch.7 output pin (Port 1)	—	—
	INT23		External interrupt request 23 input pin	—	○
	SIFD5		Slave interface data I/O pin bit5	○	—
35	P80	R	General-purpose I/O port	—	○
	AN8		10-bit A/D converter ch.8 analog input pin	—	—
	IN0_1		32-bit input capture ch.0 input pin (Port 1)	—	○
	INT24		External interrupt request 24 input pin	—	○
	SIFD6		Slave interface data I/O pin bit6	○	—
36	P81	R	General-purpose I/O port	—	○
	AN9		10-bit A/D converter ch.9 analog input pin	—	—
	IN1_1		32-bit input capture ch.1 input pin (Port 1)	—	○
	INT25		External interrupt request 25 input pin	—	○
	SIFD7		Slave interface data I/O pin bit7	○	—

(Continued)

MB91660 Series

Pin Number	Pin Name	I/O Circuit Type*1	Function	CMOS level input	CMOS level hysteresis input
37	P82	R	General-purpose I/O port	—	○
	AN10		10-bit A/D converter ch.10 analog input pin	—	—
	IN2_1		32-bit input capture ch.2 input pin (Port 1)	—	○
	INT26		External interrupt request 26 input pin	—	○
	SIFD8		Slave interface data I/O pin bit8	○	—
38	P83	R	General-purpose I/O port	—	○
	AN11		10-bit A/D converter ch.11 analog input pin	—	—
	IN3_1		32-bit input capture ch.3 input pin (Port 1)	—	○
	INT27		External interrupt request 27 input pin	—	○
	SIFD9		Slave interface data I/O pin bit9	○	—
39	P84	R	General-purpose I/O port	—	○
	AN12		10-bit A/D converter ch.12 analog input pin	—	—
	IN4_1		32-bit input capture ch.4 input pin (Port 1)	—	○
	INT28		External interrupt request 28 input pin	—	○
	SIFD10		Slave interface data I/O pin bit10	○	—
40	P85	R	General-purpose I/O port	—	○
	AN13		10-bit A/D converter ch.13 analog input pin	—	—
	IN5_1		32-bit input capture ch.5 input pin (Port 1)	—	○
	INT29		External interrupt request 29 input pin	—	○
	SIFD11		Slave interface data I/O pin bit11	○	—
41	P86	R	General-purpose I/O port	—	○
	AN14		10-bit A/D converter ch.14 analog input pin	—	—
	IN6_1		32-bit input capture ch.6 input pin (Port 1)	—	○
	INT30		External interrupt request 30 input pin	—	○
	SIFD12		Slave interface data I/O pin bit12	○	—
42	P87	R	General-purpose I/O port	—	○
	AN15		10-bit A/D converter ch.15 analog input pin	—	—
	IN7_1		32-bit input capture ch.7 input pin (Port 1)	—	○
	INT31		External interrupt request 31 input pin	—	○
	SIFD13		Slave interface data I/O pin bit13	○	—
43	PA0	R	General-purpose I/O port	—	○
	AN16		10-bit A/D converter ch.16 analog input pin	—	—
	INT16_1		External interrupt request 16 input pin (Port 1)	—	○
	SIFD14		Slave interface data I/O pin bit14	○	—

(Continued)

MB91660 Series

Pin Number	Pin Name	I/O Circuit Type*1	Function	CMOS level input	CMOS level hysteresis input
44	PA1	R	General-purpose I/O port	—	○
	AN17		10-bit A/D converter ch.17 analog input pin	—	—
	INT17_1		External interrupt request 17 input pin (Port 1)	—	○
	SIFD15		Slave interface data I/O pin bit15	○	—
45	PA2	R	General-purpose I/O port	—	○
	AN18		10-bit A/D converter ch.18 analog input pin	—	—
	TMO0_1		16-bit reload timer ch.0 output pin (Port 1)	—	—
	INT18_1		External interrupt request 18 input pin (Port 1)	—	○
	SIFCS		Slave interface chip select signal input pin	○	—
46	PA3	R	General-purpose I/O port	—	○
	AN19		10-bit A/D converter ch.19 analog input pin	—	—
	TMO1_1		16-bit reload timer ch.1 output pin (Port 1)	—	—
	INT19_1		External interrupt request 19 input pin (Port 1)	—	○
	SIFA		Slave interface address signal input pin	○	—
47	PA4	R	General-purpose I/O port	—	○
	AN20		10-bit A/D converter ch.20 analog input pin	—	—
	TMO2_1		16-bit reload timer ch.2 output pin (Port 1)	—	—
	INT20_1		External interrupt request 20 input pin (Port 1)	—	○
	SIFWR		Slave interface write strobe signal input pin	○	—
48	PA5	R	General-purpose I/O port	—	○
	AN21		10-bit A/D converter ch.21 analog input pin	—	—
	TMI0_1		16-bit reload timer ch.0 input pin (Port 1)	—	○
	INT21_1		External interrupt request 21 input pin (Port 1)	—	○
	SIFRD		Slave interface read strobe signal input pin	○	—
49	PA6	E	General-purpose I/O port	—	○
	AN22		10-bit A/D converter ch.22 analog input pin	—	—
	TMI1_1		16-bit reload timer ch.1 input pin (Port 1)	—	○
	INT22_1		External interrupt request 22 input pin (Port 1)	—	○
	SIFDRQR		Slave interface received data request signal output pin	—	—
50	PA7	E	General-purpose I/O port	—	○
	AN23		10-bit A/D converter ch.23 analog input pin	—	—
	TMI2_1		16-bit reload timer ch.2 input pin (Port 1)	—	○
	INT23_1		External interrupt request 23 input pin (Port 1)	—	○
	SIFDRQT		Slave interface transmitted data request signal output pin	—	—

(Continued)

MB91660 Series

Pin Number	Pin Name	I/O Circuit Type*1	Function	CMOS level input	CMOS level hysteresis input
51	AV _{cc}	—	10-bit A/D converter and 8-bit D/A converter analog power pin	—	—
52	AVRH	—	10-bit A/D converter analog reference voltage input pin	—	—
53	AV _{ss}	—	10-bit A/D converter and 8-bit D/A converter GND pin	—	—
54	P90	F	General-purpose I/O port	—	○
	DA0		8-bit D/A converter ch.0 analog output pin	—	—
55	P91	F	General-purpose I/O port	—	○
	DA1		8-bit D/A converter ch.1 analog output pin	—	—
56	P92	F	General-purpose I/O port	—	○
	DA2		8-bit D/A converter ch.2 analog output pin	—	—
57	PK3	C	General-purpose I/O port	—	○
	ADTRG0_3		10-bit A/D converter external trigger input pin (Port 3)	—	○
58	PK2	C	General-purpose I/O port	—	○
	ADTRG0_2		10-bit A/D converter external trigger input pin (Port 2)	—	○
59	PK1	I	General-purpose I/O port	—	○
	X0A		Sub clock (oscillation) input pin	—	○
60	PK0	I	General-purpose I/O port	—	○
	X1A		Sub clock (oscillation) I/O pin	—	—
61	V _{ss}	—	GND pin	—	—
62	X0	A	Main clock (oscillation) input pin	—	○
63	X1	A	Main clock (oscillation) I/O pin	—	—
64	MD0	H, P	Mode 0 pin. The I/O circuit type for the flash memory products is P. During normal operation, MD0=L must be input. During serial programming to flash memory, MD0=H must be input.	—	○
65	MD1	H, P	Mode 1 pin. Input must always be at the "L" level. The I/O circuit type for the flash memory products is P.	—	○
66	$\overline{\text{INIT}}$	H, P	External reset input pin. A reset is valid when $\overline{\text{INIT}}=L$. The I/O circuit type for the flash memory products is P.	—	○
67	V _{cc}	—	Power pin	—	—
68	P50	C	General-purpose I/O port	—	○
	$\overline{\text{CS}}_0$		External bus interface chip select 0 output pin	—	—
	SOUT10 (SDA10)		Multifunction serial interface ch.10 output pin. This pin operates as SOUT10 when it is used in a UART/CSIO (operation modes 0 to 2) and as SDA10 when it is used in an I ² C (operation mode 4).	—	○
	AIN0_1		Up/Down counter ch.0 AIN input pin (Port 1)	—	○

(Continued)

MB91660 Series

Pin Number	Pin Name	I/O Circuit Type*1	Function	CMOS level input	CMOS level hysteresis input
69	P51	C	General-purpose I/O port	—	○
	$\overline{CS1}$		External bus interface chip select 1 output pin	—	—
	SIN10		Multifunction serial interface ch.10 input pin	—	○
	BIN0_1		Up/Down counter ch.0 BIN input pin (Port 1)	—	○
70	P52	C	General-purpose I/O port	—	○
	$\overline{CS2}$		External bus interface chip select 2 output pin	—	—
	SCK10 (SCL10)		Multifunction serial interface ch.10 clock I/O pin. This pin operates as SCK10 when it is used in a UART/CSIO (operation modes 0 to 2) and as SCL10 when it is used in an I ² C (operation mode 4).	—	○
	ZIN0_1		Up/Down counter ch.0 ZIN input pin (Port 1)	—	○
71	P53	C	General-purpose I/O port	—	○
	$\overline{CS3}$		External bus interface chip select 3 output pin	—	—
	FRCK1		32-bit free-run timer ch.1 external clock input pin	—	○
	INT21_2		External interrupt request 21 input pin (Port 2)	—	○
72	P54	C	General-purpose I/O port	—	○
	\overline{AS}		External bus interface address strobe output pin	—	—
	SOUT11 (SDA11)		Multifunction serial interface ch.11 output pin. This pin operates as SOUT11 when it is used in a UART/CSIO (operation modes 0 to 2) and as SDA11 when it is used in an I ² C (operation mode 4).	—	○
	AIN1_1		Up/Down counter ch.1 AIN input pin (Port 1)	—	○
73	P55	C	General-purpose I/O port	—	○
	\overline{RD}		External bus interface read strobe output pin	—	—
	SIN11		Multifunction serial interface ch.11 input pin	—	○
	BIN1_1		Up/Down counter ch.1 BIN input pin (Port 1)	—	○
	ADTRG0		10-bit A/D converter external trigger input pin	—	○
74	P56	C	General-purpose I/O port	—	○
	$\overline{WR0}$		External bus interface write strobe 0 output pin	—	—
	SCK11 (SCL11)		Multifunction serial interface ch.11 clock I/O pin. This pin operates as SCK11 when it is used in a UART/CSIO (operation modes 0 to 2) and as SCL11 when it is used in an I ² C (operation mode 4).	—	○
	ZIN1_1		Up/Down counter ch.1 ZIN input pin (Port 1)	—	○
	FRCK0		32-bit free-run timer ch.0 external clock input pin	—	○
75	P57	C	General-purpose I/O port	—	○
	$\overline{WR1}$		External bus interface write strobe 1 output pin	—	—

(Continued)

MB91660 Series

Pin Number	Pin Name	I/O Circuit Type*1	Function	CMOS level input	CMOS level hysteresis input
76	P60	B	General-purpose I/O port	—	○
	RDY		External bus interface ready input pin	○	—
	AIN2_1		Up/Down counter ch.2 AIN input pin (Port 1)	—	○
77	P61	C	General-purpose I/O port	—	○
	SYSCLK		External bus interface bus clock output pin	—	—
	BIN2_1		Up/Down counter ch.2 BIN input pin (Port 1)	—	○
78	P62	C	General-purpose I/O port	—	○
	DREQ0		DMA controller (DMAC) ch.0 transfer request input pin	—	○
	ZIN2_1		Up/Down counter ch.2 ZIN input pin (Port 1)	—	○
79	P63	C	General-purpose I/O port	—	○
	DACK0		DMA controller (DMAC) ch.0 transfer request acceptance signal output pin	—	—
	FRCK1_1		32-bit free-run timer ch.1 external clock input pin (Port 1)	—	○
	INT22_2		External interrupt request 22 input pin (Port 2)	—	○
80	P64	C	General-purpose I/O port	—	○
	DEOP0		DMA controller (DMAC) ch.0 last transfer signal output pin	—	—
	AIN3_1		Up/Down counter ch.3 AIN input pin (Port 1)	—	○
81	P65	C	General-purpose I/O port	—	○
	DREQ1		DMA controller (DMAC) ch.1 transfer request input pin	—	○
	BIN3_1		Up/Down counter ch.3 BIN input pin (Port 1)	—	○
	ADTRG0_1		10-bit A/D converter external trigger input pin (Port 1)	—	○
82	P66	C	General-purpose I/O port	—	○
	DACK1		DMA controller (DMAC) ch.1 transfer request acceptance signal output pin	—	—
	ZIN3_1		Up/Down counter ch.3 ZIN input pin (Port 1)	—	○
	FRCK0_1		32-bit free-run timer ch.0 external clock input pin (Port 1)	—	○
83	P67	C	General-purpose I/O port	—	○
	DEOP1		DMA controller (DMAC) ch.1 last transfer signal output pin	—	—
	INT23_2		External interrupt request 23 input pin (Port 2)	—	○
84	P00	B	General-purpose I/O port	—	○
	D00		External bus interface data bus bit0	○	—
	TIOA0		Base timer ch.0 TIOA pin	—	—
	SOUT0_1		Multifunction serial interface ch.0 output pin (Port 1). This pin operates as SOUT0_1 when it is used in a UART/CSIO (operation modes 0 to 2).	—	—
	IN0		32-bit input capture ch.0 input pin	—	○

(Continued)

MB91660 Series

Pin Number	Pin Name	I/O Circuit Type*1	Function	CMOS level input	CMOS level hysteresis input
85	P01	B	General-purpose I/O port	—	○
	D01		External bus interface data bus bit1	○	—
	TIOB0		Base timer ch.0 TIOB pin	—	○
	SIN0_1		Multifunction serial interface ch.0 input pin (Port 1)	—	○
	IN1		32-bit input capture ch.1 input pin	—	○
86	P02	B	General-purpose I/O port	—	○
	D02		External bus interface data bus bit2	○	—
	TIOA1		Base timer ch.1 TIOA pin	—	○
	SCK0_1		Multifunction serial interface ch.0 clock I/O pin (Port 1). This pin operates as SCK0_1 when it is used in a UART/CSIO (operation modes 0 to 2).	—	○
	IN2		32-bit input capture ch.2 input pin	—	○
87	P03	B	General-purpose I/O port	—	○
	D03		External bus interface data bus bit3	○	—
	TIOB1		Base timer ch.1 TIOB pin	—	○
	IN3		32-bit input capture ch.3 input pin	—	○
88	P04	B	General-purpose I/O port	—	○
	D04		External bus interface data bus bit4	○	—
	TIOA2		Base timer ch.2 TIOA pin	—	—
	SOUT1 (SDA1)		Multifunction serial interface ch.1 output pin. This pin operates as SOUT1 when it is used in a UART/CSIO (operation modes 0 to 2) and as SDA1 when it is used in an I ² C (operation mode 4).	—	○
	IN4		32-bit input capture ch.4 input pin	—	○
89	P05	B	General-purpose I/O port	—	○
	D05		External bus interface data bus bit5	○	—
	TIOB2		Base timer ch.2 TIOB pin	—	○
	SIN1		Multifunction serial interface ch.1 input pin	—	○
	IN5		32-bit input capture ch.5 input pin	—	○
90	V _{SS}	—	GND pin	—	—
91	V _{CC}	—	Power pin	—	—

(Continued)

MB91660 Series

Pin Number	Pin Name	I/O Circuit Type*1	Function	CMOS level input	CMOS level hysteresis input
92	P06	B	General-purpose I/O port	—	○
	D06		External bus interface data bus bit6	○	—
	TIOA3		Base timer ch.3 TIOA pin	—	○
	SCK1 (SCL1)		Multifunction serial interface ch.1 clock I/O pin. This pin operates as SCK1 when it is used in a UART/CSIO (operation modes 0 to 2) and as SCL1 when it is used in an I ² C (operation mode 4).	—	○
	IN6		32-bit input capture ch.6 input pin	—	○
93	P07	B	General-purpose I/O port	—	○
	D07		External bus interface data bus bit7	○	—
	TIOB3		Base timer ch.3 TIOB pin	—	○
	IN7		32-bit input capture ch.7 input pin	—	○
94	P10	B	General-purpose I/O port	—	○
	D08		External bus interface data bus bit8	○	—
	TIOA4		Base timer ch.4 TIOA pin	—	—
	SOUT2 (SDA2)		Multifunction serial interface ch.2 output pin. This pin operates as SOUT2 when it is used in a UART/CSIO (operation modes 0 to 2) and as SDA2 when it is used in an I ² C (operation mode 4).	—	○
	AIN0		Up/Down counter ch.0 AIN input pin	—	○
	INT0		External interrupt request 0 input pin	—	○
95	P11	B	General-purpose I/O port	—	○
	D09		External bus interface data bus bit9	○	—
	TIOB4		Base timer ch.4 TIOB pin	—	○
	SIN2		Multifunction serial interface ch.2 input pin	—	○
	BIN0		Up/Down counter ch.0 BIN input pin	—	○
	INT1		External interrupt request 1 input pin	—	○
96	P12	B	General-purpose I/O port	—	○
	D10		External bus interface data bus bit10	○	—
	TIOA5		Base timer ch.5 TIOA pin	—	○
	SCK2 (SCL2)		Multifunction serial interface ch.2 clock I/O pin. This pin operates as SCK2 when it is used in a UART/CSIO (operation modes 0 to 2) and as SCL2 when it is used in an I ² C (operation mode 4).	—	○
	ZIN0		Up/Down counter ch.0 ZIN input pin	—	○
	INT2		External interrupt request 2 input pin	—	○

(Continued)

MB91660 Series

Pin Number	Pin Name	I/O Circuit Type*1	Function	CMOS level input	CMOS level hysteresis input
97	P13	B	General-purpose I/O port	—	○
	D11		External bus interface data bus bit11	○	—
	TIOB5		Base timer ch.5 TIOB pin	—	○
	INT3		External interrupt request 3 input pin	—	○
98	P14	B	General-purpose I/O port	—	○
	D12		External bus interface data bus bit12	○	—
	TIOA6		Base timer ch.6 TIOA pin	—	—
	SOUT3 (SDA3)		Multifunction serial interface ch.3 output pin. This pin operates as SOUT3 when it is used in a UART/CSIO (operation modes 0 to 2) and as SDA3 when it is used in an I ² C (operation mode 4).	—	○
	AIN1		Up/Down counter ch.1 AIN input pin	—	○
	INT4		External interrupt request 4 input pin	—	○
99	P15	B	General-purpose I/O port	—	○
	D13		External bus interface data bus bit13	○	—
	TIOB6		Base timer ch.6 TIOB pin	—	○
	SIN3		Multifunction serial interface ch.3 input pin	—	○
	BIN1		Up/Down counter ch.1 BIN input pin	—	○
	INT5		External interrupt request 5 input pin	—	○
100	P16	B	General-purpose I/O port	—	○
	D14		External bus interface data bus bit14	○	—
	TIOA7		Base timer ch.7 TIOA pin	—	○
	SCK3 (SCL3)		Multifunction serial interface ch.3 clock I/O pin. This pin operates as SCK3 when it is used in a UART/CSIO (operation modes 0 to 2) and as SCL3 when it is used in an I ² C (operation mode 4).	—	○
	ZIN1		Up/Down counter ch.1 ZIN input pin	—	○
	INT6		External interrupt request 6 input pin	—	○
101	P17	B	General-purpose I/O port	—	○
	D15		External bus interface data bus bit15	○	—
	TIOB7		Base timer ch.7 TIOB pin	—	○
	INT7		External interrupt request 7 input pin	—	○

(Continued)

MB91660 Series

Pin Number	Pin Name	I/O Circuit Type*1	Function	CMOS level input	CMOS level hysteresis input
102	P20	D*2	General-purpose I/O port	—	○
	A00		External bus interface address bus bit0	—	—
	TIOA8		Base timer ch.8 TIOA pin	—	—
	SOUT4 (SDA4)		Multifunction serial interface ch.4 output pin. This pin operates as SOUT4 when it is used in a UART/CSIO (operation modes 0 to 2) and as SDA4 when it is used in an I ² C (operation mode 4).	—	○
	AIN2		Up/Down counter ch.2 AIN input pin	—	○
103	P21	D*2	General-purpose I/O port	—	○
	A01		External bus interface address bus bit1	—	—
	TIOB8		Base timer ch.8 TIOB pin	—	○
	SIN4		Multifunction serial interface ch.4 input pin	—	○
	BIN2		Up/Down counter ch.2 BIN input pin	—	○
104	P22	Q*2	General-purpose I/O port	—	○
	A02		External bus interface address bus bit2	—	—
	TIOA9		Base timer ch.9 TIOA pin	—	○
	SCK4 (SCL4)		Multifunction serial interface ch.4 clock I/O pin. This pin operates as SCK4 when it is used in a UART/CSIO (operation modes 0 to 2) and as SCL4 when it is used in an I ² C (operation mode 4).	—	○
	ZIN2		Up/Down counter ch.2 ZIN input pin	—	○
	SIFD0_1		Slave interface data I/O pin bit0 (Port 1)	○	—
105	P23	Q*2	General-purpose I/O port	—	○
	A03		External bus interface address bus bit3	—	—
	TIOB9		Base timer ch.9 TIOB pin	—	○
	SIFD1_1		Slave interface data I/O pin bit1 (Port 1)	○	—
106	P24	Q*2	General-purpose I/O port	—	○
	A04		External bus interface address bus bit4	—	—
	TIOA10		Base timer ch.10 TIOA pin	—	—
	SOUT5 (SDA5)		Multifunction serial interface ch.5 output pin. This pin operates as SOUT5 when it is used in a UART/CSIO (operation modes 0 to 2) and as SDA5 when it is used in an I ² C (operation mode 4).	—	○
	AIN3		Up/Down counter ch.3 AIN input pin	—	○
	OUT0		32-bit output compare ch.0 output pin	—	—
	SIFD2_1		Slave interface data I/O pin bit2 (Port 1)	○	—

(Continued)

MB91660 Series

Pin Number	Pin Name	I/O Circuit Type*1	Function	CMOS level input	CMOS level hysteresis input
107	P25	Q*2	General-purpose I/O port	—	○
	A05		External bus interface address bus bit5	—	—
	TIOB10		Base timer ch.10 TIOB pin	—	○
	SIN5		Multifunction serial interface ch.5 input pin	—	○
	BIN3		Up/Down counter ch.3 BIN input pin	—	○
	OUT1		32-bit output compare ch.1 output pin	—	—
	SIFD3_1		Slave interface data I/O pin bit3 (Port 1)	○	—
108	P26	Q*2	General-purpose I/O port	—	○
	A06		External bus interface address bus bit6	—	—
	TIOA11		Base timer ch.11 TIOA pin	—	○
	SCK5 (SCL5)		Multifunction serial interface ch.5 clock I/O pin. This pin operates as SCK5 when it is used in a UART/CSIO (operation modes 0 to 2) and as SCL5 when it is used in an I ² C (operation mode 4).	—	○
	ZIN3		Up/Down counter ch.3 ZIN input pin	—	○
	OUT2		32-bit output compare ch.2 output pin	—	—
	SIFD4_1		Slave interface data I/O pin bit4 (Port 1)	○	—
109	P27	Q*2	General-purpose I/O port	—	○
	A07		External bus interface address bus bit7	—	—
	TIOB11		Base timer ch.11 TIOB pin	—	○
	OUT3		32-bit output compare ch.3 output pin	—	—
	SIFD5_1		Slave interface data I/O pin bit5 (Port 1)	○	—
110	P30	Q*2	General-purpose I/O port	—	○
	A08		External bus interface address bus bit8	—	—
	TIOA12		Base timer ch.12 TIOA pin	—	—
	SOUT6 (SDA6)		Multifunction serial interface ch.6 output pin. This pin operates as SOUT6 when it is used in a UART/CSIO (operation modes 0 to 2) and as SDA6 when it is used in an I ² C (operation mode 4).	—	○
	INT8		External interrupt request 8 input pin	—	○
	SIFD6_1		Slave interface data I/O pin bit6 (Port 1)	○	—
111	P31	Q*2	General-purpose I/O port	—	○
	A09		External bus interface address bus bit9	—	—
	TIOB12		Base timer ch.12 TIOB pin	—	○
	SIN6		Multifunction serial interface ch.6 input pin	—	○
	INT9		External interrupt request 9 input pin	—	○
	SIFD7_1		Slave interface data I/O pin bit7 (Port 1)	○	—

(Continued)

MB91660 Series

Pin Number	Pin Name	I/O Circuit Type*1	Function	CMOS level input	CMOS level hysteresis input
112	P32	Q*2	General-purpose I/O port	—	○
	A10		External bus interface address bus bit10	—	—
	TIOA13		Base timer ch.13 TIOA pin	—	○
	SCK6 (SCL6)		Multifunction serial interface ch.6 clock I/O pin. This pin operates as SCK6 when it is used in a UART/CSIO (operation modes 0 to 2) and as SCL6 when it is used in an I ² C (operation mode 4).	—	○
	INT10		External interrupt request 10 input pin	—	○
	SIFD8_1		Slave interface data I/O pin bit8 (Port 1)	○	—
113	P33	Q*2	General-purpose I/O port	—	○
	A11		External bus interface address bus bit11	—	—
	TIOB13		Base timer ch.13 TIOB pin	—	○
	INT11		External interrupt request 11 input pin	—	○
	SIFD9_1		Slave interface data I/O pin bit9 (Port 1)	○	—
114	P34	Q*2	General-purpose I/O port	—	○
	A12		External bus interface address bus bit12	—	—
	TIOA14		Base timer ch.14 TIOA pin	—	—
	SOUT7 (SDA7)		Multifunction serial interface ch.7 output pin. This pin operates as SOUT7 when it is used in a UART/CSIO (operation modes 0 to 2) and as SDA7 when it is used in an I ² C (operation mode 4).	—	○
	OUT4		32-bit output compare ch.4 output pin	—	—
	INT12		External interrupt request 12 input pin	—	○
	SIFD10_1		Slave interface data I/O pin bit10 (Port 1)	○	—
115	P35	Q*2	General-purpose I/O port	—	○
	A13		External bus interface address bus bit13	—	—
	TIOB14		Base timer ch.14 TIOB pin	—	○
	SIN7		Multifunction serial interface ch.7 input pin	—	○
	OUT5		32-bit output compare ch.5 output pin	—	—
	INT13		External interrupt request 13 input pin	—	○
	SIFD11_1		Slave interface data I/O pin bit11 (Port 1)	○	—

(Continued)

MB91660 Series

(Continued)

Pin Number	Pin Name	I/O Circuit Type*1	Function	CMOS level input	CMOS level hysteresis input
116	P36	Q*2	General-purpose I/O port	—	○
	A14		External bus interface address bus bit14	—	—
	TIOA15		Base timer ch.15 TIOA pin	—	○
	SCK7 (SCL7)		Multifunction serial interface ch.7 clock I/O pin. This pin operates as SCK7 when it is used in a UART/CSIO (operation modes 0 to 2) and as SCL7 when it is used in an I ² C (operation mode 4).	—	○
	OUT6		32-bit output compare ch.6 output pin	—	—
	INT14		External interrupt request 14 input pin	—	○
	SIFD12_1		Slave interface data I/O pin bit12 (Port 1)	○	—
117	P37	Q*2	General-purpose I/O port	—	○
	A15		External bus interface address bus bit15	—	—
	TIOB15		Base timer ch.15 TIOB pin	—	○
	OUT7		32-bit output compare ch.7 output pin	—	—
	INT15		External interrupt request 15 input pin	—	○
	SIFD13_1		Slave interface data I/O pin bit13 (Port 1)	○	—
118	P40	Q*2	General-purpose I/O port	—	○
	A16		External bus interface address bus bit16	—	—
	SOUT8 (SDA8)		Multifunction serial interface ch.8 output pin. This pin operates as SOUT8 when it is used in a UART/CSIO (operation modes 0 to 2) and as SDA8 when it is used in an I ² C (operation mode 4).	—	○
	SIFD14_1		Slave interface data I/O pin bit14 (Port 1)	○	—
119	P41	Q*2	General-purpose I/O port	—	○
	A17		External bus interface address bus bit17	—	—
	SIN8		Multifunction serial interface ch.8 input pin	—	○
	SIFD15_1		Slave interface data I/O pin bit15 (Port 1)	○	—
120	V _{cc}	—	Power pin	—	—

*1 : Refer to “■ I/O CIRCUIT TYPE” for details on the I/O circuit types.

*2 : 5 V tolerant pin.

■ I/O CIRCUIT TYPE

Type	Circuit	Remarks
A		<ul style="list-style-type: none"> • Oscillation feedback resistance approx. 1 MΩ • With standby control
B		<ul style="list-style-type: none"> • CMOS level output • CMOS level input • CMOS level hysteresis input • With pull-up control • With standby control <p>Notes:</p> <ul style="list-style-type: none"> • CMOS level input when input data, RDY pin of external bus interface and slave interface. Input other than above situations, CMOS level hysteresis input. • When this pin is used as an I²C pin, the digital output P-ch transistor is always off.

(Continued)

MB91660 Series

Type	Circuit	Remarks
C	<p>The circuit diagram for Type C shows a CMOS output stage. A pull-up resistor is connected to the output node. The output node is connected to the gates of a P-channel MOSFET (P-ch) and an N-channel MOSFET (N-ch). The P-ch MOSFET's source is connected to V_{DD} and its drain is connected to the output node. The N-ch MOSFET's source is connected to ground and its drain is connected to the output node. A pull-up control signal is connected to the gate of the P-ch MOSFET. A digital input and standby control signal are connected to an AND gate, which controls the gates of both the P-ch and N-ch MOSFETs. A resistor R is connected between the output node and ground.</p>	<ul style="list-style-type: none"> • CMOS level output • CMOS level hysteresis input • With pull-up control • With standby control <p>Note: When this pin is used as an I²C pin, the digital output P-ch transistor is always off.</p>
D	<p>The circuit diagram for Type D shows a CMOS output stage. A pull-up resistor is connected to the output node. The output node is connected to the gates of a P-channel MOSFET (P-ch) and an N-channel MOSFET (N-ch). The P-ch MOSFET's source is connected to V_{DD} and its drain is connected to the output node. The N-ch MOSFET's source is connected to ground and its drain is connected to the output node. A resistor R is connected between the output node and ground. A digital input and standby control signal are connected to an AND gate, which controls the gates of both the P-ch and N-ch MOSFETs.</p>	<ul style="list-style-type: none"> • CMOS level output • CMOS level hysteresis input • 5 V tolerant input • With standby control <p>Note: When this pin is used as an I²C pin, the digital output P-ch transistor is always off.</p>

(Continued)

Type	Circuit	Remarks
E	<p>The circuit diagram for Type E shows a CMOS input stage. A square wave source is connected to the input of a P-ch MOSFET and an N-ch MOSFET. A pull-up resistor R is connected to the input. The output is a digital signal. The circuit also includes a digital input, standby control, and analog input.</p>	<ul style="list-style-type: none"> • CMOS level output • CMOS level hysteresis input • With input control • Analog input • With pull-up control • With standby control
F	<p>The circuit diagram for Type F shows a CMOS output stage. A square wave source is connected to the output of a P-ch MOSFET and an N-ch MOSFET. A pull-up resistor R is connected to the output. The circuit also includes a digital input, standby control, and analog output.</p>	<ul style="list-style-type: none"> • CMOS level output • CMOS level hysteresis input • With input control • Analog output • With pull-up control • With standby control

(Continued)

MB91660 Series

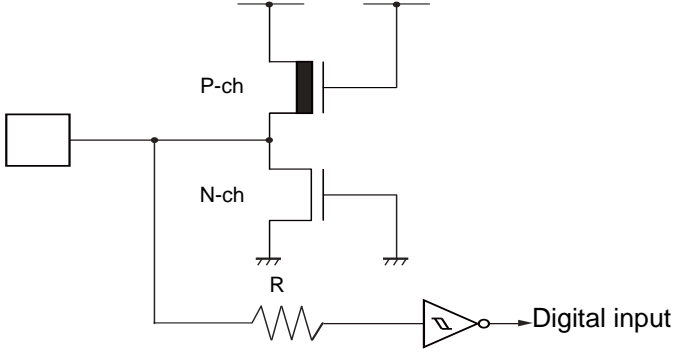
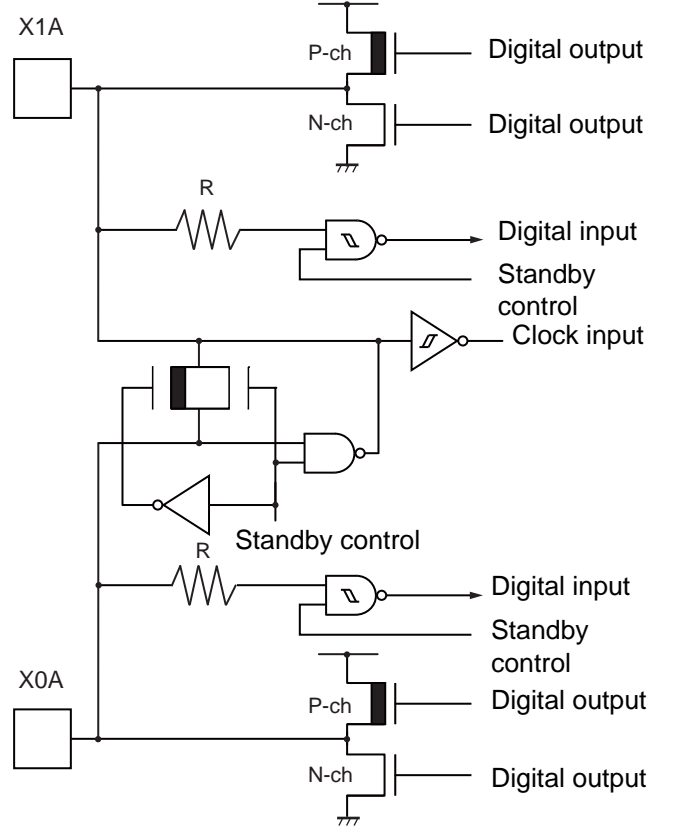
Type	Circuit	Remarks
H		CMOS level hysteresis input
I		<ul style="list-style-type: none"> • Oscillation feedback resistance approx. 10 MΩ • CMOS level output • CMOS level hysteresis input • With standby control

(Continued)

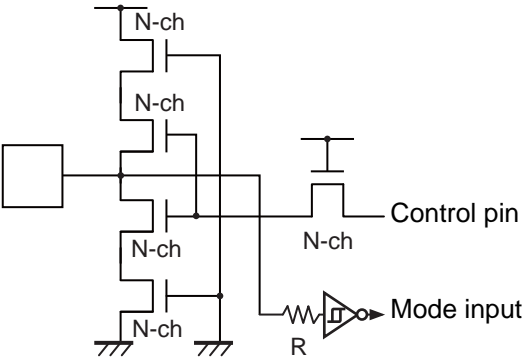
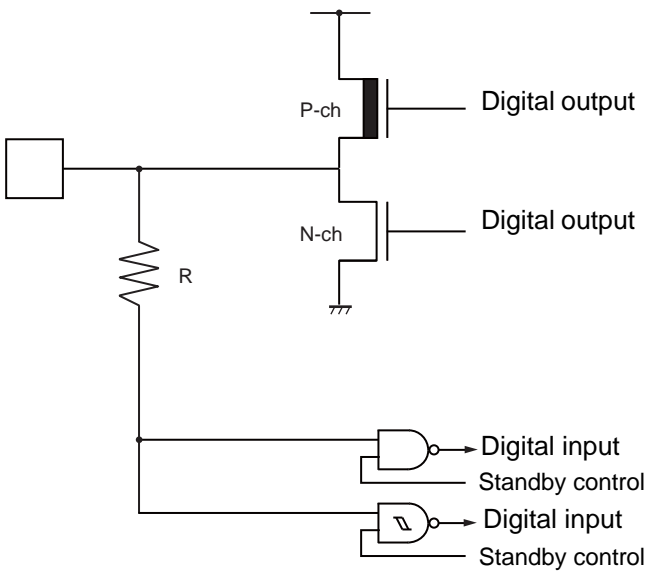
Type	Circuit	Remarks
P	 <p>The diagram shows a stack of four N-channel MOSFETs. The gates of the top three transistors are connected to a common node that is also connected to a control pin. The gates of the bottom two transistors are connected to a mode input through a resistor R. The source of the bottom transistor is grounded.</p>	<ul style="list-style-type: none"> • Flash memory product only • CMOS level hysteresis input • High voltage control for testing Flash memory
Q	 <p>The diagram shows a P-channel MOSFET and an N-channel MOSFET connected to a digital output. The gates of both transistors are connected to a common node that is also connected to a resistor R. The source of the N-channel transistor is grounded. Below the resistor R, there are two logic gates: an AND gate and an OR gate. The AND gate has two inputs: 'Digital input' and 'Standby control'. The OR gate has two inputs: 'Digital input' and 'Standby control'.</p>	<ul style="list-style-type: none"> • CMOS level output • CMOS level input • CMOS level hysteresis input • 5 V tolerant input • With standby control <p>Note: When this pin is used as an I²C pin, the digital output P-ch transistor is always off.</p>

(Continued)

MB91660 Series

(Continued)

Type	Circuit	Remarks
R	<p>The diagram shows a multi-functional pin configuration. At the top, a P-ch MOSFET is connected to a pull-up resistor and another P-ch MOSFET, which serves as a digital output. Below it, an N-ch MOSFET is connected to ground and also serves as a digital output. A pull-up control signal is connected to a resistor (R) that provides a pull-up for the digital inputs. Two digital inputs are shown, each with a standby control input connected to an AND gate. An analog input is shown at the bottom, controlled by an input control signal through a buffer and a switch.</p>	<ul style="list-style-type: none"> • CMOS level output • CMOS level input • CMOS level hysteresis input • With input control • Analog input • With pull-up control • With standby control
USB	<p>The diagram illustrates a differential signaling scheme for USB I/O. It features two differential input pairs: UDP(+) and UDM(-). Each pair consists of a differential input and a corresponding output. The Direction control signal is used to route the signals through a series of buffers and AND gates to determine the output direction.</p>	USB I/O pin

■ PRECAUTIONS FOR HANDLING THE DEVICES

Any semiconductor devices have inherently a certain rate of failure. The possibility of failure is greatly affected by the conditions in which they are used (circuit conditions, environmental conditions, etc.). This page describes precautions that must be observed to minimize the chance of failure and to obtain higher reliability from your FUJITSU semiconductor devices.

1. Precautions for Product Design

This section describes precautions when designing electronic equipment using semiconductor devices.

- Absolute Maximum Ratings

Semiconductor devices can be permanently damaged by application of stress (voltage, current, temperature, etc.) in excess of absolute maximum ratings. Do not exceed these ratings.

- Recommended Operating Conditions

The recommended operating conditions are required in order to ensure the normal operation of the semiconductor device. All of the device's electrical characteristics are warranted when the device is operated within these ranges.

Always use semiconductor devices within their recommended operating condition ranges. Operation outside these ranges may adversely affect reliability and could result in device failure.

No warranty is made with respect to uses, operating conditions, or combinations not represented on the data sheet. Users considering application outside the listed conditions are advised to contact their FUJITSU representatives beforehand.

- Processing and Protection of Pins

These precautions must be followed when handling the pins which connect semiconductor devices to power supply and input/output functions.

- (1) Preventing Over-Voltage and Over-Current Conditions

Exposure to voltage or current levels in excess of maximum ratings at any pin is likely to cause deterioration within the device, and in extreme cases leads to permanent damage of the device. Try to prevent such overvoltage or over-current conditions at the design stage.

- (2) Protection of Output Pins

Shorting of output pins to supply pins or other output pins, or connection to large capacitance can cause large current flows. Such conditions if present for extended periods of time can damage the device. Therefore, avoid this type of connection.

- (3) Handling of Unused Input Pins

Unconnected input pins with very high impedance levels can adversely affect stability of operation. Such pins should be connected through an appropriate resistance to a power supply pin or ground pin.

MB91660 Series

- Latch-up

Semiconductor devices are constructed by the formation of P-type and N-type areas on a substrate. When subjected to abnormally high voltages, internal parasitic PNPN junctions (called thyristor structures) may be formed, causing large current levels in excess of several hundred mA to flow continuously at the power supply pin. This condition is called latch-up.

- Note: The occurrence of latch-up not only causes loss of reliability in the semiconductor device, but can cause injury or damage from high heat, smoke or flame. To prevent this from happening, do the following:
- (a) Be sure that voltages applied to pins do not exceed the absolute maximum ratings. This should include attention to abnormal noise, surge levels, etc.
 - (b) Be sure that abnormal current flows do not occur during the power-on sequence.

- Observance of Safety Regulations and Standards

Most countries in the world have established standards and regulations regarding safety, protection from electromagnetic interference, etc. Customers are requested to observe applicable regulations and standards in the design of products.

- Fail-Safe Design

Any semiconductor devices have inherently a certain rate of failure. You must protect against injury, damage or loss from such failures by incorporating safety design measures into your facility and equipment such as redundancy, fire protection, and prevention of over-current levels and other abnormal operating conditions.

- Precautions Related to Usage of Devices

FUJITSU semiconductor devices are intended for use in standard applications (computers, office automation and other office equipment, industrial, communications, and measurement equipment, personal or household devices, etc.).

CAUTION: Customers considering the use of our products in special applications where failure or abnormal operation may directly affect human lives or cause physical injury or property damage, or where extremely high levels of reliability are demanded (such as aerospace systems, atomic energy controls, sea floor repeaters, vehicle operating controls, medical devices for life support, etc.) are requested to consult with FUJITSU sales representatives before such use. The company will not be responsible for damages arising from such use without prior approval.

2. Precautions for Package Mounting

Package mounting may be either lead insertion type or surface mount type. In either case, for heat resistance during soldering, you should only mount under FUJITSU's recommended conditions. For detailed information about mount conditions, contact your FUJITSU sales representative.

- Lead Insertion Type

Mounting of lead insertion type packages onto printed circuit boards may be done by two methods: direct soldering on the board, or mounting by using a socket.

Direct mounting onto boards normally involves processes for inserting leads into through-holes on the board and using the flow soldering (wave soldering) method of applying liquid solder.

In this case, the soldering process usually causes leads to be subjected to thermal stress in excess of the absolute ratings for storage temperature. Mounting processes should conform to FUJITSU recommended mounting conditions.

If socket mounting is used, differences in surface treatment of the socket contacts and IC lead surfaces can lead to contact deterioration after long periods. For this reason it is recommended that the surface treatment of socket contacts and IC leads be verified before mounting.

- Surface Mount Type

Surface mount packaging has longer and thinner leads than lead-insertion packaging, and therefore leads are more easily deformed or bent. The use of packages with higher pin counts and narrower pin pitch results in increased susceptibility to open connections caused by deformed pins, or shorting due to solder bridges.

You must use appropriate mounting techniques. FUJITSU recommends the solder reflow method, and has established a ranking of mounting conditions for each product. Users are advised to mount packages in accordance with FUJITSU ranking of recommended conditions.

- Lead-Free Packaging

Note: When ball grid array (BGA) packages with Sn-Ag-Cu balls are mounted using Sn-Pb eutectic soldering, junction strength may be reduced under some conditions of use.

- Storage of Semiconductor Devices

Because plastic chip packages are formed from plastic resins, exposure to natural environmental conditions will cause absorption of moisture. During mounting, the application of heat to a package that has absorbed moisture can cause surfaces to peel, reducing moisture resistance and causing packages to crack. To prevent, do the following:

- (a) Avoid exposure to rapid temperature changes, which cause moisture to condense inside the product. Store products in locations where temperature changes are slight.
- (b) Use dry boxes for product storage. Products should be stored below 70% relative humidity, and at temperatures between 5 °C and 30 °C. When you open Dry Package that recommends humidity 40% to 70% relative humidity.
- (c) When necessary, FUJITSU packages semiconductor devices in highly moisture-resistant aluminum laminate bags, with a silica gel desiccant. Devices should be sealed in their aluminum laminate bags for storage.
- (d) Avoid storing packages where they are exposed to corrosive gases or high levels of dust.

MB91660 Series

- Baking

Packages that have absorbed moisture may be de-moisturized by baking (heat drying). Follow the FUJITSU recommended conditions for baking.

Condition: + 125 °C/24 h

- Static Electricity

Because semiconductor devices are particularly susceptible to damage by static electricity, you must take the following precautions:

- (a) Maintain relative humidity in the working environment between 40% and 70%. Use of an apparatus for ion generation may be needed to remove electricity.
- (b) Electrically ground all conveyors, solder vessels, soldering irons and peripheral equipment.
- (c) Eliminate static body electricity by the use of rings or bracelets connected to ground through high resistance (on the level of 1 MΩ). Wearing of conductive clothing and shoes, use of conductive floor mats and other measures to minimize shock loads is recommended.
- (d) Ground all fixtures and instruments, or protect with anti-static measures.
- (e) Avoid the use of styrofoam or other highly static-prone materials for storage of completed board assemblies.

- Precautions for Use Environment

Reliability of semiconductor devices depends on ambient temperature and other conditions as described above.

For reliable performance, do the following:

- (1) Humidity

Prolonged use in high humidity can lead to leakage in devices as well as printed circuit boards. If high humidity levels are anticipated, consider anti-humidity processing.

- (2) Discharge of Static Electricity

When high-voltage charges exist close to semiconductor devices, discharges can cause abnormal operation. In such cases, use anti-static measures or processing to prevent discharges.

- (3) Corrosive Gases, Dust, or Oil

Exposure to corrosive gases or contact with dust or oil may lead to chemical reactions that will adversely affect the device. If you use devices in such conditions, consider ways to prevent such exposure or to protect the devices.

- (4) Radiation, Including Cosmic Radiation

Most devices are not designed for environments involving exposure to radiation or cosmic radiation. Users should provide shielding as appropriate.

- (5) Smoke, Flame

Note : Plastic molded devices are flammable, and therefore should not be used near combustible substances.

If devices begin to smoke or burn, there is danger of the release of toxic gases.

Customers considering the use of FUJITSU products in other special environmental conditions should consult with FUJITSU sales representatives.

■ HANDLING DEVICES

• Power supply pins

In products with multiple V_{CC} and V_{SS} pins, respective pins at the same potential are interconnected within the device in order to prevent malfunctions such as latch-up. However, all of these pins should be connected externally to the power supply or ground lines in order to reduce electromagnetic emission levels, to prevent abnormal operation of strobe signals caused by the rise in the ground level, and to conform to the total output current rating. Moreover, connect the current supply source with the V_{CC} and V_{SS} pins of this device at low impedance.

It is also advisable that a ceramic capacitor of approximately $0.1 \mu\text{F}$ be connected as a bypass capacitor between V_{CC} and V_{SS} near this device.

• Crystal oscillator circuit

Noise near the X0 and X1 pins may cause the device to malfunction. Design the printed circuit board so that X0, X1, the crystal oscillator (or ceramic oscillator), and the bypass capacitor to ground are located as close to the device as possible.

It is strongly recommended that the PC board artwork be designed such that the X0 and X1 pins are surrounded by ground plane as this is expected to produce stable operation.

If a 32 kHz oscillator is used (X0A, X1A), use the PK2 pin for an input that changes as infrequently as possible. Furthermore, take steps such as shown in the following figure to prevent the X0A and PK2 wiring from running parallel to each other.

If 32 kHz oscillation is not used, there are no limitations.

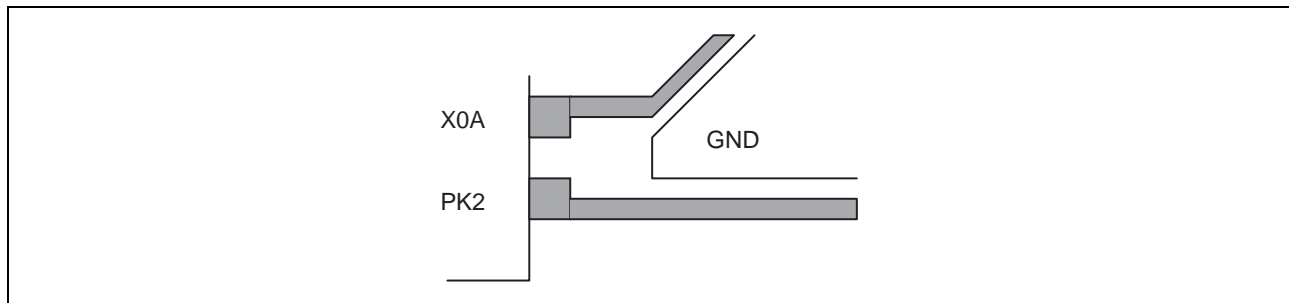

MB91660 Series

- Using an external clock

When using an external clock, the clock signal should be input to the X0 pin only and the X1 pin should be kept open.

- Example of Using an External Clock

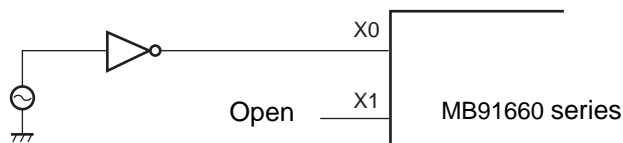

- C Pin

As MB91660 series includes an internal regulator, always connect a bypass capacitor of approximately 4.7 μF to the C pin for use by the regulator.

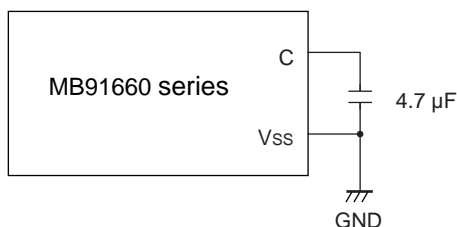

- Mode pins (MD0, MD1)

Connect the MD pin (MD0, MD1) directly to V_{CC} or V_{SS} pins. Design the printed circuit board such that the pull-up/down resistance stays low, as well as the distance between the mode pins and V_{CC} pins or V_{SS} pins is as short as possible and the connection impedance is low, when the pins are pulled-up/down such as for switching the pin level and rewriting the Flash memory data. It is because of preventing the device erroneously switching to test mode due to noise.

- Notes on power-on

- To ensure that the internal regulator and the oscillator have stabilized immediately after the power is turned on, keep an "L" level input connected to the $\overline{\text{INIT}}$ pin for the duration of the regulator voltage stabilization wait time + the oscillator start time of the oscillator + the main oscillator stabilization wait time.
- Turn power on/off in the following order
Turning on : $V_{\text{CC}} \rightarrow AV_{\text{CC}} \rightarrow \text{AVRH}$
Turning off : $\text{AVRH} \rightarrow AV_{\text{CC}} \rightarrow V_{\text{CC}}$
- Release the reset ($\overline{\text{INIT}}$ pin "L" level to "H" level) after the power supply has stabilized.

- Caution on operations during PLL clock mode

On this microcontroller, if in case the crystal oscillator breaks off or an external reference clock input stops while the PLL clock mode is selected, a self-oscillator circuit contained in the PLL may continue its operation at its self-running frequency.

However, Fujitsu will not guarantee results of operations if such failure occurs.

■ BLOCK DIAGRAM

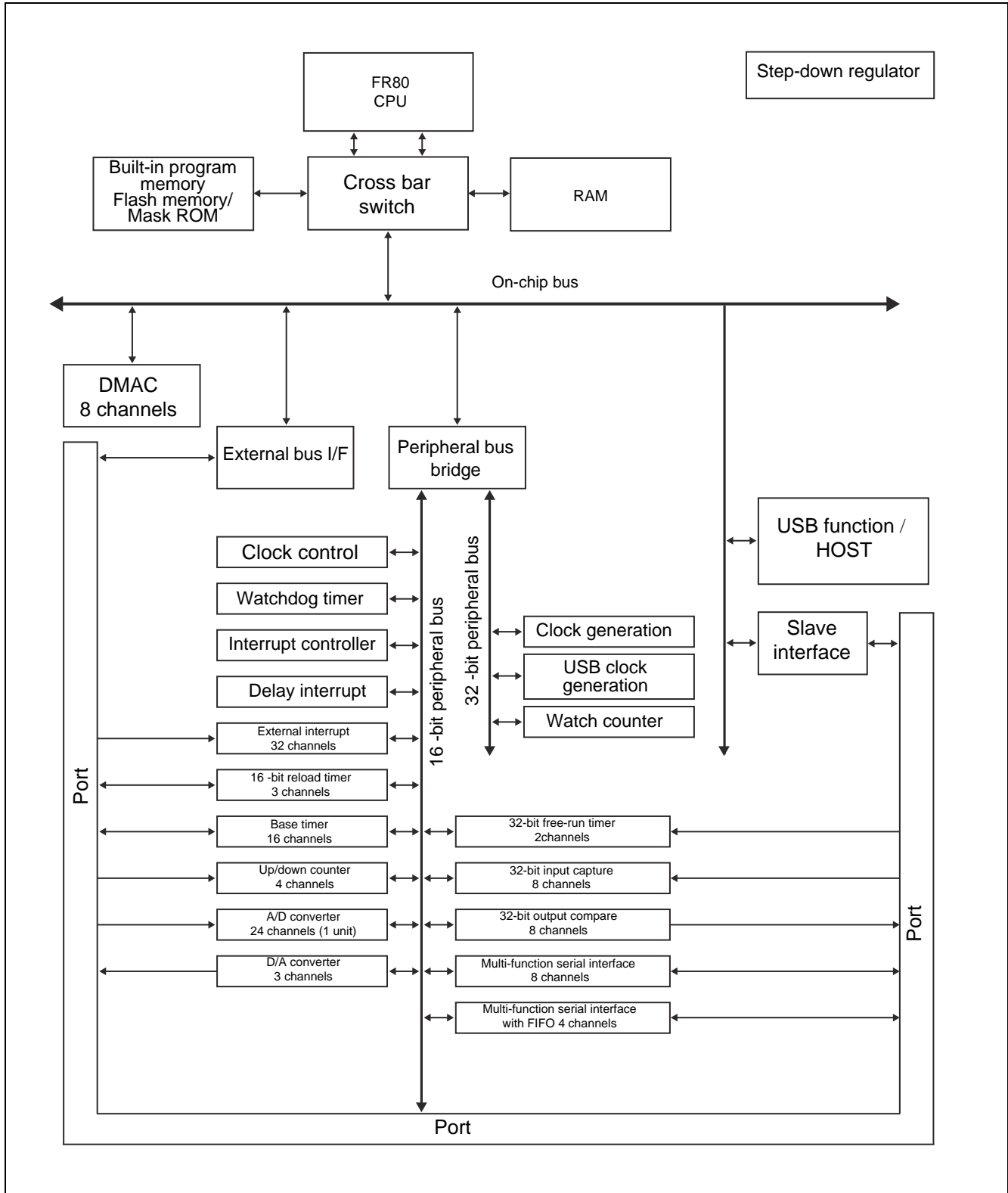

■ MEMORY SPACE

1. Memory Space

The FR family has 4 Gbytes of logical address space (2^{32} addresses) available to the CPU by linear access.

- Direct Addressing Areas

The following areas in the address space are used as I/O areas.

These areas are called direct addressing areas, and the address of an operand in these areas can be specified directly within an instruction. The size of the directly addressable area depends on the length of the data being accessed as follows.

- Byte data access : 0000 0000_H to 0000 00FF_H
- Half word data access : 0000 0000_H to 0000 01FF_H
- Word data access : 0000 0000_H to 0000 03FF_H

2. Memory Map

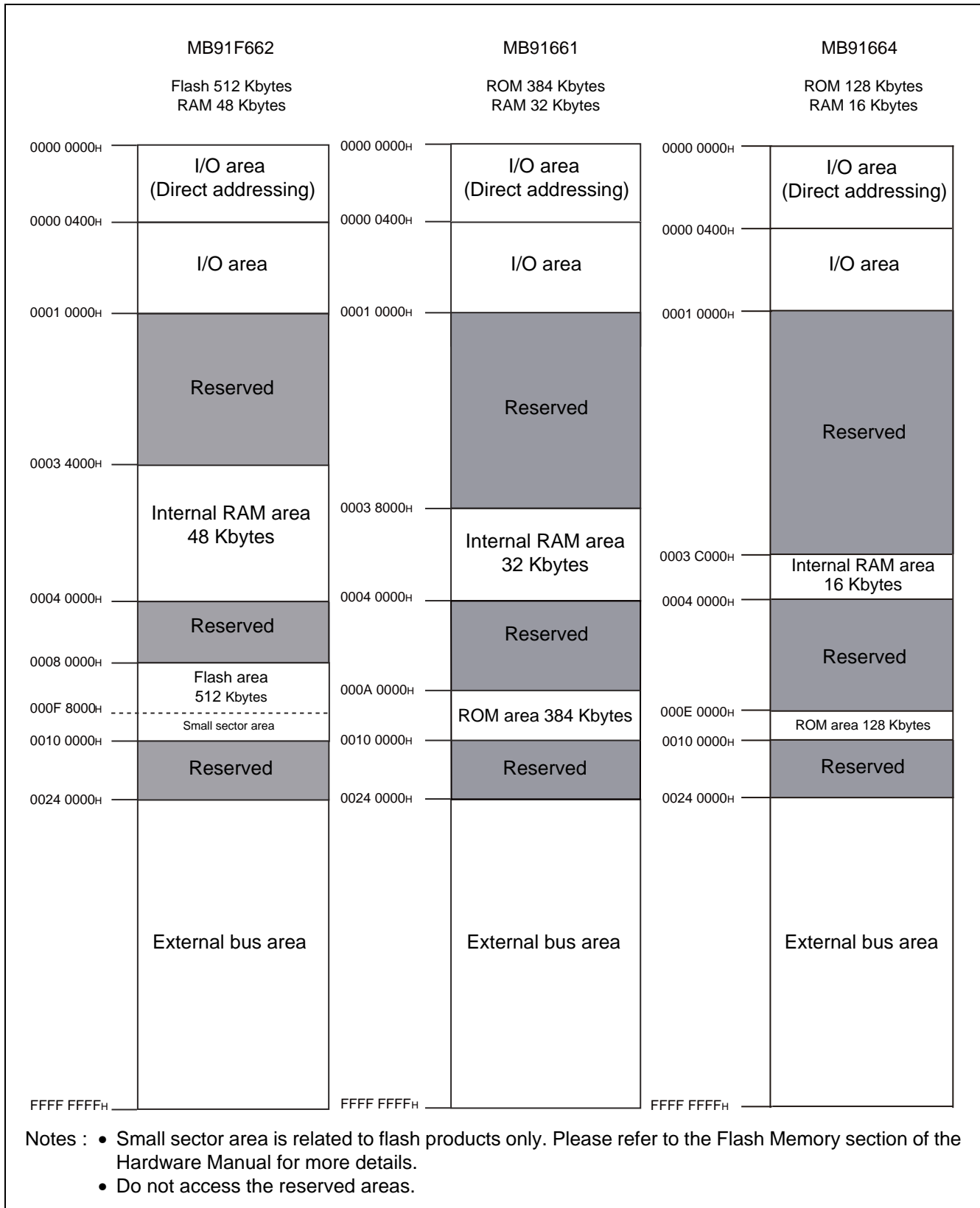

MB91660 Series

■ I/O MAP

[How to read the table]

Address	Register				Block
	+ 0	+ 1	+ 2	+ 3	
0000 0000 _H	PDR0 [R/W] B, H XXXXXXXX	PDR1 [R/W] B, H XXXXXXXX	PDR2 [R/W] B, H XXXXXXXXXXXX	PDR3 [R/W] B, H XXXXXXXX	Port data register
0000 003C _H	WDTCR0 [R/W] B, H - 0 - - 0000	WDTCPR0 [R/W] B, H 00000000	—		Watchdog timer
0000 0040 _H	EIRR0 [R/W] B, H, W 00000000	ENIR0 [R/W] B, H, W 00000000	ELVR0 [R/W] B, H, W 00000000 00000000		External interrupt 0 to 7

Initial value after reset

“1” : Initial value“1”

“0” : Initial value“0”

“X” : Initial value undefined

“-” : Reserved bit or undefined bit

— : Reserved area

Access unit

(B : byte, H : half word, W : word)

Read/write attribute

“R” : Indicates that there is a read only bit.

“R/W” : Indicates that there is a read/write bit.

“W” : Indicates that there is a write only bit.

Register name (column 1 of the register is at address 4n, column 2 is at address 4 n + 2...)

Leftmost register address (For word-length access, column 1 of the register is the MSB of the data.)

Notes : • When performing a data access, the addresses should be as below.

- Word access : Address should be multiples of 4 (least significant 2 bits should be “00_B”)

- Half word access : Address should be multiples of 2 (least significant bit should be “0_B”)

- Byte access : —

• Do not access the reserved areas.

MB91660 Series

Address	Register				Block
	+ 0	+ 1	+ 2	+ 3	
0000 0000 _H	PDR0 [R/W] B,H XXXXXXXX	PDR1 [R/W] B,H XXXXXXXX	PDR2 [R/W] B,H XXXXXXXX	PDR3 [R/W] B,H XXXXXXXX	Port data register
0000 0004 _H	PDR4 [R/W] B,H XXXXXXXX	PDR5 [R/W] B,H XXXXXXXX	PDR6 [R/W] B,H XXXXXXXX	PDR7[R/W] B,H XXXXXXXX	
0000 0008 _H	PDR8 [R/W] B,H XXXXXXXX	PDR9 [R/W] B,H ----- XXX	PDRA [R/W] B XXXXXXXX	—	
0000 000C _H	—				
0000 0010 _H	PDRG [R/W] B,H XXXXXXXX	PDRH [R/W] B,H ---- XXXX	—		
0000 0014 _H	PDRK [R/W] B ---- XXXX	—			
0000 0018 _H to 0000 001C _H	—				
0000 0020 _H to 0000 0038 _H	—				Reserved
0000 003C _H	WDTCR0[R/W] B,H - 0 - 0000	WDTCPR0[R/W] B,H 00000000	—		Watchdog timer
0000 0040 _H	EIRR0[R/W] B,H,W 00000000	ENIR0[R/W] B,H,W 00000000	ELVR0[R/W] B,H,W 00000000 00000000		External interrupt 0 to 7
0000 0044 _H	DICR [R/W] B ----- 0	—			Delay interrupt
0000 0048 _H	TMRLRA0 [R/W] H XXXXXXXX XXXXXXXX		TMR0 [R] H XXXXXXXX XXXXXXXX		16-bit reload timer ch.0
0000 004C _H	—		TMCSR0 [R/W] H -- 000000 -- 000000		
0000 0050 _H	TMRLRA1 [R/W] H XXXXXXXX XXXXXXXX		TMR1 [R] H XXXXXXXX XXXXXXXX		16-bit reload timer ch.1
0000 0054 _H	—		TMCSR1 [R/W] H -- 000000 -- 000000		
0000 0058 _H	TMRLRA2 [R/W] H XXXXXXXX XXXXXXXX		TMR2 [R] H XXXXXXXX XXXXXXXX		16-bit reload timer ch.2
0000 005C _H	—		TMCSR2 [R/W] H -- 000000 -- 000000		

(Continued)

MB91660 Series

Address	Register				Block
	+ 0	+ 1	+ 2	+ 3	
0000 0060 _H	SCR0 [R/W] B,H,W 0 - - 00000	SMR0 [R/W] B,H,W 000 - 0000	SSR0 [R,R/W] B,H,W 0 - 000011	ESCR0 [R/W] B,H,W - 0000000	Multi-function serial interface ch.0
0000 0064 _H	RDR0[R]/TDR0[W] B,H,W*1 ----- 0 00000000		BGR10[R/W] H,W 00000000	BGR00[R/W] H,W 00000000	
0000 0068 _H	SCR1[R/W] IBCR1[R,R/W] B,H,W 0 - - 00000	SMR1 [R/W] B,H,W 000 - 0000	SSR1 [R,R/W] B,H,W 0 - 000011	ESCR1[R/W] IBSR1[R,R/W] B,H,W - 0000000	Multi-function serial interface ch.1
0000 006C _H	RDR1[R]/TDR1[W] B,H,W*1 ----- 0 00000000		BGR11[R/W] H,W 00000000	BGR01[R/W] H,W 00000000	
0000 0070 _H	ISMK1 [R/W] B,H*2 -----	ISBA1 [R/W] B,H*2 -----	—		
0000 0074 _H	SCR2[R/W] IBCR2[R,R/W] B,H,W*2 0 - - 00000	SMR2 [R/W] B,H,W 000 - 0000	SSR2 [R,R/W] B,H,W 0 - 000011	ESCR2[R/W] IBSR2 [R,R/W] B,H,W*2 - 0000000	Multi-function serial interface ch.2
0000 0078 _H	RDR2[R]/TDR2[W] B,H,W*1 ----- 0 00000000		BGR12[R/W] H,W 00000000	BGR02[R/W] H,W 00000000	
0000 007C _H	ISMK2 [R/W] B,H*2 -----	ISBA2 [R/W] B,H*2 -----	—		
0000 0080 _H	SCR3[R/W] IBCR3[R,R/W] B,H,W*2 0 - - 00000	SMR3 [R/W] B,H,W 000 - 0000	SSR3 [R,R/W] B,H,W 0 - 000011	ESCR3[R/W] IBSR3[R,R/W] B,H,W*2 - 0000000	Multi-function serial interface ch.3
0000 0084 _H	RDR3[R]/TDR3[W] B,H,W*1 ----- 0 00000000		BGR13[R/W] H,W 00000000	BGR03[R/W] H,W 00000000	
0000 0088 _H	ISMK3 [R/W] B,H*2 -----	ISBA3 [R/W] B,H*2 -----	—		
0000 008C _H	SCR4[R/W] IBCR4[R,R/W] B,H,W*2 0 - - 00000	SMR4 [R/W] B,H,W 000 - 0000	SSR4 [R,R/W] B,H,W 0 - 000011	ESCR4[R/W] IBSR4[R,R/W] B,H,W*2 - 0000000	Multi-function serial interface ch.4
0000 0090 _H	RDR4[R]/TDR4[W] B,H,W*1 ----- 0 00000000		BGR14[R/W] H,W 00000000	BGR04[R/W] H,W 00000000	
0000 0094 _H	ISMK4 [R/W] B,H*2 -----	ISBA4 [R/W] B,H*2 -----	—		

(Continued)

MB91660 Series

Address	Register				Block
	+ 0	+ 1	+ 2	+ 3	
0000 0098 _H	SCR5[R/W] IBCR5[R,R/W] B,H,W*2 0 - - 00000	SMR5 [R/W] B,H,W 000 - 0000	SSR5 [R,R/W] B,H,W 0 - 000011	ESCR5[R/W] IBSR5[R,R/W] B,H,W*2 - 0000000	Multi-function serial interface ch.5
0000 009C _H	RDR5[R]/TDR5[W] B,H,W*1 ----- 0 00000000		BGR15 [R/W] H,W 00000000	BGR05 [R/W] H,W 00000000	
0000 00A0 _H	ISMK5 [R/W] B,H*2 -----	ISBA5 [R/W] B,H*2 -----	—		
0000 00A4 _H	SCR6[R/W] IBCR6[R,R/W] B,H,W*2 0 - - 00000	SMR6 [R/W] B,H,W 000 - 0000	SSR6 [R,R/W] B,H,W 0 - 000011	ESCR6[R/W] IBSR6[R,R/W] B,H,W*2 - 0000000	Multi-function serial interface ch.6
0000 00A8 _H	RDR6[R]/TDR6[W] B,H,W*1 ----- 0 00000000		BGR16 [R/W] H,W 00000000	BGR06 [R/W] H,W 00000000	
0000 00AC _H	ISMK6 [R/W] B,H*2 -----	ISBA6 [R/W] B,H*2 -----	—		
0000 00B0 _H	SCR7 [R/W] IBCR7[R,R/W] B,H,W*2 0 - - 00000	SMR7 [R/W] B,H,W 000 - 0000	SSR7 [R,R/W] B,H,W 0 - 000011	ESCR7 [R/W] IBSR7 [R,R/W] B,H,W*2 - 0000000	Multi-function serial interface ch.7
0000 00B4 _H	RDR7[R]/TDR7[W] B,H,W*1 ----- 0 00000000		BGR17 [R/W] H,W 00000000	BGR07 [R/W] H,W 00000000	
0000 00B8 _H	ISMK7 [R/W] B,H*2 -----	ISBA7 [R/W] B,H*2 -----	—		
0000 00BC _H	—				Reserved
0000 00C0 _H	RDRM0 [R]/ TDRM0[W] B,H,W 00000000	RDRM1 [R]/ TDRM1[W] B,H,W 00000000	RDRM2 [R]/ TDRM2[W] B,H,W 00000000	RDRM3 [R]/ TDRM3[W] B,H,W 00000000	Multi-function serial interface data register (mirror)
0000 00C4 _H	RDRM4 [R]/ TDRM4[W] B,H,W 00000000	RDRM5 [R]/ TDRM5[W] B,H,W 00000000	RDRM6 [R]/ TDRM6[W] B,H,W 00000000	RDRM7 [R]/ TDRM7[W] B,H,W 00000000	
0000 00C8 _H	SSEL0123 [R/W] B ----- 00	—	SSEL4567 [R/W] B ----- 00	—	Multi-function serial interface serial clock selection
0000 00CC _H	—				Reserved

(Continued)

MB91660 Series

Address	Register				Block
	+ 0	+ 1	+ 2	+ 3	
0000 00D0 _H	SCR8 [R/W] IBCR8 [R,R/W] B,H,W*2 0 - - 00000	SMR8 [R/W] B,H,W 000 - 0000	SSR8 [R,R/W] B,H,W 0 - 000011	ESCR8 [R/W] IBSR8 [R,R/W] B,H,W*2 - 0000000	Multi-function serial interface ch. 8 (FIFO)
0000 00D4 _H	RDR8[R]/TDR8[W] B,H,W*1 ----- 0 00000000		BGR18 [R/W] H,W 00000000	BGR08 [R,R/W] H,W 00000000	
0000 00D8 _H	ISMK8 [R/W] B,H*2 -----	ISBA8 [R/W] B,H*2 -----	—		
0000 00DC _H	FCR18 [R/W] B,H,W --- 00100	FCR08 [R,R/W] B,H,W - 0000000	FBYTE28 [R/W] B,H,W 00000000	FBYTE18 [R/W] B,H,W 00000000	
0000 00E0 _H	SCR9 [R/W] IBCR9 [R,R/W] B,H,W*2 0 - - 00000	SMR9 [R/W] B,H,W 000 - 0000	SSR9 [R,R/W] B,H,W 0 - 000011	ESCR9 [R/W] IBSR9[R,R/W] B,H,W*2 - 0000000	Multi-function serial interface ch. 9 (FIFO)
0000 00E4 _H	RDR9[R]/TDR9[W] B,H,W*1 ----- 0 00000000		BGR19 [R/W] H,W 00000000	BGR09 [R/W] H,W 00000000	
0000 00E8 _H	ISMK9 [R/W] B,H*2 -----	ISBA9 [R/W] B,H*2 -----	—		
0000 00EC _H	FCR19 [R/W] B,H,W --- 00100	FCR09 [R,R/W] B,H,W - 0000000	FBYTE29 [R/W] B,H,W 00000000	FBYTE19 [R/W] B,H,W 00000000	
0000 00F0 _H	SCR10 [R/W] IBCR10 [R,R/W] B,H,W*2 0 - - 00000	SMR10 [R/W] B,H,W 000- 0000	SSR10 [R,R/W] B,H,W 0- 000011	ESCR10 [R/W] IBSR10 [R,R/W] B,H,W*2 - 0000000	Multi-function serial interface ch.10 (FIFO)
0000 00F4 _H	RDR10[R]/TDR10[W] B,H,W*1 ----- 0 00000000		BGR110 [R/W] H,W 00000000	BGR010 [R/W] H,W 00000000	
0000 00F8 _H	ISMK10 [R/W] B,H*2 -----	ISBA10 [R/W] B,H*2 -----	—		
0000 00FC _H	FCR110 [R/W] B,H,W --- 00100	FCR010 [R,R/W] B,H,W - 0000000	FBYTE210 [R/W] B,H,W 00000000	FBYTE110 [R/W] B,H,W 00000000	

(Continued)

MB91660 Series

Address	Register				Block
	+ 0	+ 1	+ 2	+ 3	
0000 0100 _H	SCR11 [R/W] IBCR11 [R,R/W] B,H,W*2 0 - 00000	SMR11 [R/W] B,H,W 000- 0000	SSR11 [R,R/W] B,H,W 0- 000011	ESCR11 [R/W] IBSR11 [R,R/W] B,H,W*2 - 0000000	Multi-function serial interface ch.11 (FIFO)
0000 0104 _H	RDR11[R]/TDR11[W] B,H,W*1 ----- 0 00000000		BGR111 [R/W] H,W 00000000	BGR011 [R/W] H,W 00000000	
0000 0108 _H	ISMK11 [R/W] B,H*2 -----	ISBA11 [R/W] B,H*2 -----	—		
0000 010C _H	FCR111 [R/W] B,H,W --- 00100	FCR011 [R,R/W] B,H,W - 0000000	FBYTE211 [R/W] B,H,W 00000000	FBYTE111 [R/W] B,H,W 00000000	
0000 0110 _H	EIRR1[R/W] B,H,W 00000000	ENIR1[R/W] B,H,W 00000000	ELVR1[R/W] B,H,W 00000000 00000000		External interrupt 8 to 15
0000 0114 _H	EIRR2[R/W] B,H,W 00000000	ENIR2[R/W] B,H,W 00000000	ELVR2[R/W] B,H,W 00000000 00000000		External interrupt 16 to 23
0000 0118 _H	EIRR3[R/W] B,H,W 00000000	ENIR3[R/W] B,H,W 00000000	ELVR3[R/W] B,H,W 00000000 00000000		External interrupt 24 to 31
0000 011C _H	—				Reserved
0000 0120 _H	ADCR0[R/W] B,H 000- 0000	ADSR0[R,R/W] B,H 00- - - 000	—		A/D converter
0000 0124 _H	SCCR0[R,R/W] B,H 1000- 000	SFNS0[R/W] B,H ---- 0000	SCFD0[R] B,H XXXXXXXX XX- XXXXX		
0000 0128 _H	—	SCIS20[R/W] B 00000000	SCIS10[R/W] B,H 00000000	SCIS00[R/W] B,H 00000000	
0000 012C _H	PCCR0[R,R/W] B,H 1000- 000	PFNS0[R/W] B,H ----- 00	PCFD0[R] B,H XXXXXXXX XXXXXXXX		
0000 0130 _H	PCIS0[R/W] B 00000000	—	CMPD0[R/W] B,H 00000000	CMPCR0[R/W] B,H 00000000	
0000 0134 _H	—	ADSS20[R/W] B 00000000	ADSS10[R/W] B,H 00000000	ADSS00[R/W] B,H 00000000	
0000 0138 _H	ADST00[R/W] B,H 00100000	ADST10[R/W] B,H 00100000	ADCT0[R/W] B ----- 111	—	

(Continued)

MB91660 Series

Address	Register				Block
	+ 0	+ 1	+ 2	+ 3	
0000 013C _H	—				Reserved
0000 0140 _H	BT0TMR[R]H 00000000 00000000		BT0TMCR[R/W] B,H -0000000 00000000		Base timer ch.0
0000 0144 _H	—	BT0STC[R/W]B 0000-000	—		
0000 0148 _H	BT0PCSR/BT0PRLH[R/W]H XXXXXXXX XXXXXXXXX		BT0PDUT/BT0PRLH/BT0DTBF [R/W]H XXXXXXXX XXXXXXXXX		
0000 014C _H	—				
0000 0150 _H	BT1TMR[R]H 00000000 00000000		BT1TMCR[R/W] B,H -0000000 00000000		Base timer ch.1
0000 0154 _H	—	BT1STC[R/W]B 0000-000	—		
0000 0158 _H	BT1PCSR/BT1PRLH[R/W]H XXXXXXXX XXXXXXXXX		BT1PDUT/BT1PRLH/BT1DTBF [R/W]H XXXXXXXX XXXXXXXXX		
0000 015C _H	—				
0000 0160 _H	BT2TMR[R]H 00000000 00000000		BT2TMCR [R/W] B,H -0000000 00000000		Base timer ch.2
0000 0164 _H	—	BT2STC[R/W]B 0000-000	—		
0000 0168 _H	BT2PCSR/BT2PRLH[R/W]H XXXXXXXX XXXXXXXXX		BT2PDUT/BT2PRLH/BT2DTBF [R/W]H XXXXXXXX XXXXXXXXX		
0000 016C _H	—				
0000 0170 _H	BT3TMR[R]H 00000000 00000000		BT3TMCR[R/W] B,H -0000000 00000000		Base timer ch.3
0000 0174 _H	—	BT3STC[R/W]B 0000-000	—		
0000 0178 _H	BT3PCSR/BT3PRLH[R/W]H XXXXXXXX XXXXXXXXX		BT3PDUT/BT3PRLH/BT3DTBF [R/W]H XXXXXXXX XXXXXXXXX		
0000 017C _H	BTSEL0123 [R/W] B 00000000	—			
0000 0180 _H	DACR0[R/W] B,H,W ----- 0	DADR0[R/W] B,H,W XXXXXXXX	DACR1[R/W] B,H,W ----- 0	DADR1[R/W] B,H,W XXXXXXXX	D/A converter
0000 0184 _H	DACR2[R/W] B,H ----- 0	DADR2[R/W] B,H XXXXXXXX	—		
0000 0188 _H to 0000 018C _H	—				

(Continued)

MB91660 Series

Address	Register				Block
	+ 0	+ 1	+ 2	+ 3	
0000 0190 _H to 0000 01A8 _H	—				Reserved
0000 01AC _H	ADCHE [R/W] B,H,W ----- 11111111 11111111 11111111				A/D channel enable
0000 01B0 _H	IRPR0H [R] B 000- ----	—	IRPR1H [R] B,H 000- 000-	IRPR1L [R] B,H 000- 000-	Interrupt request batch read function
0000 01B4 _H	IRPR2H [R] B,H,W 0000- ---	IRPR2L [R] B,H,W 000- ----	IRPR3H [R] B,H,W 0000- ---	IRPR3L [R] B,H,W 00000- ---	
0000 01B8 _H	IRPR4H [R] B,H,W 0000- ---	IRPR4L [R] B,H,W 000000- -	IRPR5H [R] B,H,W 0000- ---	IRPR5L [R] B,H,W 0000- ---	
0000 01BC _H	IRPR6H [R] B,H,W 0000- ---	IRPR6L [R] B,H,W 0000- ---	IRPR7H [R] B,H,W 0000- 0--	IRPR7L [R] B,H,W 0000- ---	
0000 01C0 _H	RCRH0 [W] H,W 00000000	RCRL0 [W] B,H,W 00000000	UDCRH0 [R] H,W 00000000	UDCRL0 [R] B,H,W 00000000	Up/down counter ch.0
0000 01C4 _H	CCR0 [R, R/W] B,H 00000000 -0001000		—	CSR0 [R,R/W] B 00000000	
0000 01C8 _H	—				
0000 01CC _H	—				Reserved
0000 01D0 _H	RCRH1 [W] H,W 00000000	RCRL1 [W] B,H,W 00000000	UDCRH1 [R] H,W 00000000	UDCRL1 [R] B,H,W 00000000	Up/down counter ch.1
0000 01D4 _H	CCR1 [R,R/W] B,H 00000000 -0001000		—	CSR1 [R,R/W] B 00000000	
0000 01D8 _H	—				
0000 01DC _H	—				Reserved
0000 01E0 _H	RCRH2 [W] H,W 00000000	RCRL2 [W] B,H,W 00000000	UDCRH2 [R] H,W 00000000	UDCRL2 [R] B,H,W 00000000	Up/down counter ch.2
0000 01E4 _H	CCR2 [R, R/W] B,H 00000000 -0001000		—	CSR2 [R,R/W] B 00000000	
0000 01E8 _H	—				
0000 01EC _H	—				Reserved

(Continued)

MB91660 Series

Address	Register				Block
	+ 0	+ 1	+ 2	+ 3	
0000 01F0 _H	RCRH3 [W] H,W 00000000	RCRL3 [W] B,H,W 00000000	UDCRH3 [R] H,W 00000000	UDCRL3 [R] B,H,W 00000000	Up/down counter ch.3
0000 01F4 _H	CCR3 [R,R/W] B,H 00000000 -0001000		—	CSR3 [R,R/W] B 00000000	
0000 01F8 _H	—				
0000 01FC _H	—				Reserved
0000 0200 _H	CPCLR0 [R/W] W 11111111 11111111 11111111 11111111				32-bit Free-run timer ch.0
0000 0204 _H	TCDT0 [R/W] W 00000000 00000000 00000000 00000000				
0000 0208 _H	TCCSH0 [R/W] B,H 0- - - - 00	TCCSL0 [R/W] B,H - 1- 00000	—		
0000 020C _H	IPCP0 [R] W XXXXXXXX XXXXXXXX XXXXXXXX XXXXXXXX				32-bit Input capture ch.0 to ch.3
0000 0210 _H	IPCP1 [R] W XXXXXXXX XXXXXXXX XXXXXXXX XXXXXXXX				
0000 0214 _H	IPCP2 [R] W XXXXXXXX XXXXXXXX XXXXXXXX XXXXXXXX				
0000 0218 _H	IPCP3 [R] W XXXXXXXX XXXXXXXX XXXXXXXX XXXXXXXX				
0000 021C _H	—	ICS01 [R/W] B 00000000	—	ICS23 [R/W] B 00000000	
0000 0220 _H	IPCP4 [R] W XXXXXXXX XXXXXXXX XXXXXXXX XXXXXXXX				32-bit Input capture ch.4 to ch.7
0000 0224 _H	IPCP5 [R] W XXXXXXXX XXXXXXXX XXXXXXXX XXXXXXXX				
0000 0228 _H	IPCP6 [R] W XXXXXXXX XXXXXXXX XXXXXXXX XXXXXXXX				
0000 022C _H	IPCP7 [R] W XXXXXXXX XXXXXXXX XXXXXXXX XXXXXXXX				
0000 0230 _H	—	ICS45 [R/W] B 00000000	—	ICS67 [R/W] B 00000000	

(Continued)

MB91660 Series

Address	Register				Block
	+ 0	+ 1	+ 2	+ 3	
0000 0234 _H	OCCP0 [R/W] W 00000000 00000000 00000000 00000000				32-bit Output compare ch.0 to ch.3
0000 0238 _H	OCCP1 [R/W] W 00000000 00000000 00000000 00000000				
0000 023C _H	OCCP2 [R/W] W 00000000 00000000 00000000 00000000				
0000 0240 _H	OCCP3 [R/W] W 00000000 00000000 00000000 00000000				
0000 0244 _H	OCSH1 [R/W] B,H,W --- 0 - - 00	OCSL0 [R/W] B,H,W 0000- - 00	OCSH3 [R/W] B,H,W --- 0 - - 00	OCSL2 [R/W] B,H,W 0000- - 00	
0000 0248 _H	OCCP4 [R/W] W 00000000 00000000 00000000 00000000				32-bit Output compare ch.4 to ch.7
0000 024C _H	OCCP5 [R/W] W 00000000 00000000 00000000 00000000				
0000 0250 _H	OCCP6 [R/W] W 00000000 00000000 00000000 00000000				
0000 0254 _H	OCCP7 [R/W] W 00000000 00000000 00000000 00000000				
0000 0258 _H	OCSH5 [R/W] B,H,W --- 0 - - 00	OCSL4 [R/W] B,H,W 0000- - 00	OCSH7 [R/W] B,H,W --- 0 - - 00	OCSL6 [R/W] B,H,W 0000- - 00	
0000 025C _H	FRTSEL [R/W] B ----- 00	—			Free-run timer selector
0000 0260 _H	CPCLR1 [R/W] W 11111111 11111111 11111111 11111111				32-bit Free-run timer ch.1
0000 0264 _H	TCDT1 [R/W] W 00000000 00000000 00000000 00000000				
0000 0268 _H	TCCSH1 [R/W] B,H 0- - - - - 00	TCCSL1 [R/W] B,H - 1- 00000	—		
0000 026C _H to 0000 031C _H	—				Reserved
0000 0320 _H	FCTLR[R/W] H - 0 - - 1011 - - - - - - - -		—	FSTR[R] B - - - - - - - 1	Flash memory control
0000 0324 _H to 0000 0334 _H	—				Reserved
0000 0338 _H	—		WREN[R/W] B,H 00000000 00000000		Wild register
0000 033C _H	—				

(Continued)

MB91660 Series

Address	Register				Block
	+ 0	+ 1	+ 2	+ 3	
0000 0340 _H to 0000 037C _H	—				Reserved
0000 0380 _H	WRAR00[R/W] W ----- -- XXXXXX XXXXXXXX XXXXXX--				Wild register
0000 0384 _H	WRDR00[R/W] W XXXXXXXX XXXXXXXX XXXXXXXX XXXXXXXX				
0000 0388 _H	WRAR01[R/W] W ----- -- XXXXXX XXXXXXXX XXXXXX--				
0000 038C _H	WRDR01[R/W] W XXXXXXXX XXXXXXXX XXXXXXXX XXXXXXXX				
0000 0390 _H	WRAR02[R/W] W ----- -- XXXXXX XXXXXXXX XXXXXX--				
0000 0394 _H	WRDR02[R/W] W XXXXXXXX XXXXXXXX XXXXXXXX XXXXXXXX				
0000 0398 _H	WRAR03[R/W] W ----- -- XXXXXX XXXXXXXX XXXXXX--				
0000 039C _H	WRDR03[R/W] W XXXXXXXX XXXXXXXX XXXXXXXX XXXXXXXX				
0000 03A0 _H	WRAR04[R/W] W ----- -- XXXXXX XXXXXXXX XXXXXX--				
0000 03A4 _H	WRDR04[R/W] W XXXXXXXX XXXXXXXX XXXXXXXX XXXXXXXX				
0000 03A8 _H	WRAR05[R/W] W ----- -- XXXXXX XXXXXXXX XXXXXX--				
0000 03AC _H	WRDR05[R/W] W XXXXXXXX XXXXXXXX XXXXXXXX XXXXXXXX				
0000 03B0 _H	WRAR06[R/W] W ----- -- XXXXXX XXXXXXXX XXXXXX--				
0000 03B4 _H	WRDR06[R/W] W XXXXXXXX XXXXXXXX XXXXXXXX XXXXXXXX				
0000 03B8 _H	WRAR07[R/W] W ----- -- XXXXXX XXXXXXXX XXXXXX--				
0000 03BC _H	WRDR07[R/W] W XXXXXXXX XXXXXXXX XXXXXXXX XXXXXXXX				
0000 03C0 _H	WRAR08[R/W] W ----- -- XXXXXX XXXXXXXX XXXXXX--				
0000 03C4 _H	WRDR08[R/W] W XXXXXXXX XXXXXXXX XXXXXXXX XXXXXXXX				

(Continued)

MB91660 Series

Address	Register				Block
	+ 0	+ 1	+ 2	+ 3	
0000 03C8 _H	WRAR09[R/W] W ----- XXXXXX XXXXXXXX XXXXXX--				Wild register
0000 03CC _H	WRDR09[R/W] W XXXXXXXX XXXXXXXX XXXXXXXX XXXXXXXX				
0000 03D0 _H	WRAR10[R/W] W ----- XXXXXX XXXXXXXX XXXXXX--				
0000 03D4 _H	WRDR10[R/W] W XXXXXXXX XXXXXXXX XXXXXXXX XXXXXXXX				
0000 03D8 _H	WRAR11[R/W] W ----- XXXXXX XXXXXXXX XXXXXX--				
0000 03DC _H	WRDR11[R/W] W XXXXXXXX XXXXXXXX XXXXXXXX XXXXXXXX				
0000 03E0 _H	WRAR12[R/W] W ----- XXXXXX XXXXXXXX XXXXXX--				
0000 03E4 _H	WRDR12[R/W] W XXXXXXXX XXXXXXXX XXXXXXXX XXXXXXXX				
0000 03E8 _H	WRAR13[R/W] W ----- XXXXXX XXXXXXXX XXXXXX--				
0000 03EC _H	WRDR13[R/W] W XXXXXXXX XXXXXXXX XXXXXXXX XXXXXXXX				
0000 03F0 _H	WRAR14[R/W] W ----- XXXXXX XXXXXXXX XXXXXX--				
0000 03F4 _H	WRDR14[R/W] W XXXXXXXX XXXXXXXX XXXXXXXX XXXXXXXX				
0000 03F8 _H	WRAR15[R/W] W ----- XXXXXX XXXXXXXX XXXXXX--				
0000 03FC _H	WRDR15[R/W] W XXXXXXXX XXXXXXXX XXXXXXXX XXXXXXXX				
0000 0400 _H	DDR0 [R/W] B,H 00000000	DDR1 [R/W] B,H 00000000	DDR2 [R/W] B,H 00000000	DDR3 [R/W] B,H 00000000	
0000 0404 _H	DDR4 [R/W] B,H 00000000	DDR5 [R/W] B,H 00000000	DDR6 [R/W] B,H 00000000	DDR7[R/W] B,H 00000000	
0000 0408 _H	DDR8 [R/W] B,H 00000000	DDR9 [R/W] B,H ----- 000	DDRA [R/W] B 00000000	—	
0000 040C _H	—				
0000 0410 _H	DDRG [R/W] B,H 00000000	DDRH [R/W] B,H ---- 0000	—		
0000 0414 _H	DDRK [R/W] B ---- 0000	—			

(Continued)

MB91660 Series

Address	Register				Block
	+ 0	+ 1	+ 2	+ 3	
0000 0418 _H to 0000 041C _H	—				Data direction register
0000 0420 _H	PCR0 [R/W] B,H 00000000	PCR1 [R/W] B,H 00000000	—		Pull-up control register
0000 0424 _H	—	PCR5 [R/W] B 00000000	PCR6 [R/W] B,H 00000000	PCR7[R/W] B,H 00000000	
0000 0428 _H	PCR8 [R/W] B,H 00000000	PCR9 [R/W] B,H ----- 000	PCRA [R/W] B 00000000	—	
0000 042C _H to 0000 0430 _H	—				
0000 0434 _H	PCRK [R/W] B ---- 00--	—			
0000 0438 _H to 0000 043C _H	—				
0000 0440 _H	ICR00 [R,R/W] B,H,W --- 11111	ICR01 [R,R/W] B,H,W --- 11111	ICR02 [R,R/W] B,H,W --- 11111	ICR03 [R,R/W] B,H,W --- 11111	Interrupt control
0000 0444 _H	ICR04 [R,R/W] B,H,W --- 11111	ICR05 [R,R/W] B,H,W --- 11111	ICR06 [R,R/W] B,H,W --- 11111	ICR07 [R,R/W] B,H,W --- 11111	
0000 0448 _H	ICR08 [R,R/W] B,H,W --- 11111	ICR09 [R,R/W] B,H,W --- 11111	ICR10 [R,R/W] B,H,W --- 11111	ICR11 [R,R/W] B,H,W --- 11111	
0000 044C _H	ICR12 [R,R/W] B,H,W --- 11111	ICR13 [R,R/W] B,H,W --- 11111	ICR14 [R,R/W] B,H,W --- 11111	ICR15 [R,R/W] B,H,W --- 11111	
0000 0450 _H	ICR16 [R,R/W] B,H,W --- 11111	ICR17 [R,R/W] B,H,W --- 11111	ICR18 [R,R/W] B,H,W --- 11111	ICR19 [R,R/W] B,H,W --- 11111	
0000 0454 _H	ICR20 [R,R/W] B,H,W --- 11111	ICR21 [R,R/W] B,H,W --- 11111	ICR22 [R,R/W] B,H,W --- 11111	ICR23 [R,R/W] B,H,W --- 11111	
0000 0458 _H	ICR24 [R,R/W] B,H,W --- 11111	ICR25 [R,R/W] B,H,W --- 11111	ICR26 [R,R/W] B,H,W --- 11111	ICR27 [R,R/W] B,H,W --- 11111	
0000 045C _H	ICR28 [R,R/W] B,H,W --- 11111	ICR29 [R,R/W] B,H,W --- 11111	ICR30 [R,R/W] B,H,W --- 11111	ICR31 [R,R/W] B,H,W --- 11111	

(Continued)

MB91660 Series

Address	Register				Block
	+ 0	+ 1	+ 2	+ 3	
0000 0460 _H	ICR32 [R,R/W] B,H,W --- 11111	ICR33 [R,R/W] B,H,W --- 11111	ICR34 [R,R/W] B,H,W --- 11111	ICR35 [R,R/W] B,H,W --- 11111	Interrupt control
0000 0464 _H	ICR36 [R,R/W] B,H,W --- 11111	ICR37 [R,R/W] B,H,W --- 11111	ICR38 [R,R/W] B,H,W --- 11111	ICR39 [R,R/W] B,H,W --- 11111	
0000 0468 _H	ICR40 [R,R/W] B,H,W --- 11111	ICR41 [R,R/W] B,H,W --- 11111	ICR42 [R,R/W] B,H,W --- 11111	ICR43 [R,R/W] B,H,W --- 11111	
0000 046C _H	ICR44 [R,R/W] B,H,W --- 11111	ICR45 [R,R/W] B,H,W --- 11111	ICR46 [R,R/W] B,H,W --- 11111	ICR47 [R,R/W] B,H,W --- 11111	
0000 0470 _H to 0000 047C _H	—				Reserved
0000 0480 _H	RSTRR [R] B,H,W 11-X- - - X*3	RSTCR [R/W] B,H,W 000 - - - - 0	STBCR [R/W] B,H,W 0000 - - 11	SLPRR [R/W] B,H,W 00000000	Reset control/ Power consumption control
0000 0484 _H	—				
0000 0488 _H	DIVR0 [R/W] B,H 000- - - - -	DIVR1 [R/W] B,H 0001- - - -	DIVR2 [R/W] B 0011- - - -	—	Clock division control
0000 048C _H	—				
0000 0490 _H	IORR0 [R/W] B,H,W - 0000000	IORR1 [R/W] B,H,W - 0000000	IORR2 [R/W] B,H,W - 0000000	IORR3 [R/W] B,H,W - 0000000	Peripheral DMA transmission request control
0000 0494 _H	IORR4 [R/W] B,H,W - 0000000	IORR5 [R/W] B,H,W - 0000000	IORR6 [R/W] B,H,W - 0000000	IORR7 [R/W] B,H,W - 0000000	
0000 0498 _H to 0000 049C _H	—				Reserved
0000 04A0 _H	PFR0 [R/W] B,H 00000000	PFR1 [R/W] B,H 00000000	PFR2 [R/W] B,H 00000000	PFR3 [R/W] B,H 00000000	Port function register
0000 04A4 _H	PFR4 [R/W] B,H 00000000	PFR5 [R/W] B,H 00000000	PFR6 [R/W] B,H 00- 00- 0-	PFR7[R/W] B,H 00000000	
0000 04A8 _H	PFR8 [R/W] B 00000000	—	PFRA [R/W] B 00- 00000	—	
0000 04AC _H	—				
0000 04B0 _H	PFRG [R/W] B,H - 000- 000	PFRH [R/W] B,H - - - - - 0- 0	—		
0000 04B4 _H	—				

(Continued)

MB91660 Series

Address	Register				Block
	+ 0	+ 1	+ 2	+ 3	
0000 04B8 _H	EPFR0 [R/W] B,H -- 000000	EPFR1 [R/W] B,H -- 000000	EPFR2 [R/W] B,H -- 000000	EPFR3 [R/W] B,H -- 000000	Extended port function register
0000 04BC _H	EPFR4 [R/W] B,H 00000000	EPFR5 [R/W] B,H 00000000	EPFR6 [R/W] B,H 00000000	EPFR7 [R/W] B,H --- 00000	
0000 04C0 _H	EPFR8 [R/W] B,H --- 00000	EPFR9 [R/W] B,H --- 00000	EPFR10 [R/W] B,H --- 00000	EPFR11 [R/W] B,H --- 00000	
0000 04C4 _H	EPFR12 [R/W] B,H --- 00000	EPFR13 [R/W] B,H --- 00000	EPFR14 [R/W] B,H --- 00000	EPFR15 [R/W] B,H --- 00000	
0000 04C8 _H	EPFR16 [R/W] B,H --- 00000	EPFR17 [R/W] B,H --- 00000	EPFR18 [R/W] B,H 00000000	EPFR19 [R/W] B,H ---- 0001	
0000 04CC _H	EPFR20 [R/W] B,H -- 000000	EPFR21 [R/W] B,H -- 000000	EPFR22 [R/W] B,H -- 000000	EPFR23 [R/W] B,H -- 000000	
0000 04D0 _H	EPFR24 [R/W] B,H -- 000000	EPFR25 [R/W] B,H -- 000000	EPFR26 [R/W] B,H -- 000000	EPFR27 [R/W] B,H -- 000000	
0000 04D4 _H	EPFR28 [R/W] B,H 00000000	EPFR29 [R/W] B,H 00000000	EPFR30 [R/W] B,H ---- 0000	EPFR31 [R/W] B,H - 0000000	
0000 04D8 _H	EPFR32 [R/W] B,H 00000000	EPFR33 [R/W] B,H -- 000000	EPFR34 [R/W] B,H - 0000000	EPFR35 [R/W] B,H ----- 00	
0000 04DC _H	—				
0000 04E0 _H to 0000 04EC _H	—				Reserved
0000 04F0 _H	ICSEL0[R/W] B,H,W ----- 000	ICSEL1[R/W] B,H,W ----- 000	ICSEL2[R/W] B,H,W ----- 000	ICSEL3[R/W] B,H,W ----- 000	DMA start request clear select function
0000 04F4 _H	ICSEL4[R/W] B,H,W ----- 00	ICSEL5[R/W] B,H,W ----- 000	ICSEL6[R/W] B,H,W ----- 00	ICSEL7[R/W] B,H,W ----- 0	
0000 04F8 _H	ICSEL8[R/W] B,H,W ----- 00	ICSEL9[R/W] B,H,W ----- 000	ICSEL10[R/W] B,H,W ---- 0000	ICSEL11[R/W] B,H,W ---- 0000	
0000 04FC _H	ICSEL12[R/W] B,H ---- 0000	ICSEL13[R/W] B,H ----- 0 - 0	ICSEL14[R/W] B ----- 00	—	

(Continued)

MB91660 Series

Address	Register				Block
	+ 0	+ 1	+ 2	+ 3	
0000 0500 _H to 0000 050C _H	—				Reserved
0000 0510 _H	CSELR [R/W] B,H,W 001- - - 00	CMONR [R] B,H,W 001- - - 00	MTMCR [R/W] B,H,W 00001111	STMCR [R/W] B,H,W 0000- 111	Clock generation/ Main timer/ Sub timer
0000 0514 _H	PLLCR [R/W] B,H - - 000000 11110000		CSTBR [R/W] B - 0000000	—	
0000 0518 _H	WCRD [R] B,H - - 000000	WCRL [R/W] B,H - - 000000	WCCR [R,R/W] B 00- - 0000	—	Clock counter
0000 051C _H	UCCR [R/W] B - - - - - 001	—			USB clock generation
0000 0520 _H to 0000 05FC _H	—				Reserved
0000 0600 _H	ASR0 [R/W] W 00000000 00000000 - - - - - 1111- 001				External bus I/F
0000 0604 _H	ASR1 [R/W] W XXXXXXXX XXXXXXXX - - - - - XXXX- XX0				
0000 0608 _H	ASR2 [R/W] W XXXXXXXX XXXXXXXX - - - - - XXXX- XX0				
0000 060C _H	ASR3 [R/W] W XXXXXXXX XXXXXXXX - - - - - XXXX- XX0				
0000 0610 _H to 0000 063C _H	—				
0000 0640 _H	ACR0[R/W] W - - - - - 00- - 00- 0				
0000 0644 _H	ACR1[R/W] W - - - - - XX- - XX- X				
0000 0648 _H	ACR2[R/W] W - - - - - XX- - XX- X				
0000 064C _H	ACR3[R/W] W - - - - - XX- - XX- X				
0000 0650 _H to 0000 067C _H	—				
0000 0680 _H	AWR0 [R/W] W - - - - 1111 00000000 11110000 00000- 0-				

(Continued)

MB91660 Series

Address	Register				Block
	+ 0	+ 1	+ 2	+ 3	
0000 0684 _H	AWR1 [R/W] W ---- XXXX XXXXXXXXXXX XXXXXXXXXXX XXXXX- X-				External bus I/F
0000 0688 _H	AWR2 [R/W] W ---- XXXX XXXXXXXXXXX XXXXXXXXXXX XXXXX- X-				
0000 068C _H	AWR3 [R/W] W ---- XXXX XXXXXXXXXXX XXXXXXXXXXX XXXXX- X-				
0000 0690 _H to 0000 06BC _H	—				
0000 06C0 _H	DMAR0 [R/W] W ----- 0000				
0000 06C4 _H	DMAR1 [R/W] W ----- 0000				
0000 06C8 _H	DMAR2 [R/W] W ----- 0000				
0000 06CC _H	DMAR3 [R/W] W ----- 0000				
0000 06D0 _H to 0000 06FC _H	—				Reserved
0000 0700 _H to 0000 0BFC _H	—				

(Continued)

MB91660 Series

Address	Register				Block
	+ 0	+ 1	+ 2	+ 3	
0000 0C00 _H	DCCR0 [R/W] W 0 - - - - 000 - - 00 - - 00 00000000 0 - 000000				DMAC
0000 0C04 _H	DCSR0 [R, R/W] H 0 - - - - - - - - - - 000		DTCR0 [R/W] H 00000000 00000000		
0000 0C08 _H	DSAR0 [R/W] W XXXXXXXX XXXXXXXX XXXXXXXX XXXXXXXX				
0000 0C0C _H	DDAR0 [R/W] W XXXXXXXX XXXXXXXX XXXXXXXX XXXXXXXX				
0000 0C10 _H	DCCR1 [R/W] W 0 - - - - 000 - - 00 - - 00 00000000 0 - 000000				
0000 0C14 _H	DCSR1 [R, R/W] H 0 - - - - - - - - - - 000		DTCR1 [R/W] H 00000000 00000000		
0000 0C18 _H	DSAR1 [R/W] W XXXXXXXX XXXXXXXX XXXXXXXX XXXXXXXX				
0000 0C1C _H	DDAR1 [R/W] W XXXXXXXX XXXXXXXX XXXXXXXX XXXXXXXX				
0000 0C20 _H	DCCR2 [R/W] W 0 - - - - 000 - - 00 - - 00 00000000 0 - 000000				
0000 0C24 _H	DCSR2 [R, R/W] H 0 - - - - - - - - - - 000		DTCR2 [R/W] H 00000000 00000000		
0000 0C28 _H	DSAR2 [R/W] W XXXXXXXX XXXXXXXX XXXXXXXX XXXXXXXX				
0000 0C2C _H	DDAR2 [R/W] W XXXXXXXX XXXXXXXX XXXXXXXX XXXXXXXX				
0000 0C30 _H	DCCR3 [R/W] W 0 - - - - 000 - - 00 - - 00 00000000 0 - 000000				
0000 0C34 _H	DCSR3 [R, R/W] H 0 - - - - - - - - - - 000		DTCR3 [R/W] H 00000000 00000000		
0000 0C38 _H	DSAR3 [R/W] W XXXXXXXX XXXXXXXX XXXXXXXX XXXXXXXX				
0000 0C3C _H	DDAR3 [R/W] W XXXXXXXX XXXXXXXX XXXXXXXX XXXXXXXX				
0000 0C40 _H	DCCR4 [R/W] W 0 - - - - 000 - - 00 - - 00 00000000 0 - 000000				
0000 0C44 _H	DCSR4 [R, R/W] H 0 - - - - - - - - - - 000		DTCR4 [R/W] H 00000000 00000000		
0000 0C48 _H	DSAR4 [R/W] W XXXXXXXX XXXXXXXX XXXXXXXX XXXXXXXX				
0000 0C4C _H	DDAR4 [R/W] W XXXXXXXX XXXXXXXX XXXXXXXX XXXXXXXX				

(Continued)

MB91660 Series

Address	Register				Block
	+ 0	+ 1	+ 2	+ 3	
0000 0C50 _H	DCCR5 [R/W] W 0- - - - 000 - - 00- - 00 00000000 0- 000000				DMAC
0000 0C54 _H	DCSR5 [R, R/W] H 0- - - - - - - - - - 000		DTCR5 [R/W] H 00000000 00000000		
0000 0C58 _H	DSAR5 [R/W] W XXXXXXXX XXXXXXXX XXXXXXXX XXXXXXXX				
0000 0C5C _H	DDAR5 [R/W] W XXXXXXXX XXXXXXXX XXXXXXXX XXXXXXXX				
0000 0C60 _H	DCCR6 [R/W] W 0- - - - 000 - - 00- - 00 00000000 0- 000000				
0000 0C64 _H	DCSR6 [R, R/W] H 0- - - - - - - - - - 000		DTCR6 [R/W] H 00000000 00000000		
0000 0C68 _H	DSAR6 [R/W] W XXXXXXXX XXXXXXXX XXXXXXXX XXXXXXXX				
0000 0C6C _H	DDAR6 [R/W] W XXXXXXXX XXXXXXXX XXXXXXXX XXXXXXXX				
0000 0C70 _H	DCCR7 [R/W] W 0- - - - 000 - - 00- - 00 00000000 0- 000000				
0000 0C74 _H	DCSR7 [R, R/W] H 0- - - - - - - - - - 000		DTCR7 [R/W] H 00000000 00000000		
0000 0C78 _H	DSAR7 [R/W] W XXXXXXXX XXXXXXXX XXXXXXXX XXXXXXXX				
0000 0C7C _H	DDAR7 [R/W] W XXXXXXXX XXXXXXXX XXXXXXXX XXXXXXXX				
0000 0C80 _H to 0000 0DF0 _H	—				
0000 0DF4 _H	—			DILVR [R,R/W] B - - - 11111	
0000 0DF8 _H	DMACR [R/W] W 0- - - - - - - - - - 0- - - - - - - - - -				

(Continued)

MB91660 Series

Address	Register				Block
	+ 0	+ 1	+ 2	+ 3	
0000 0DFC _H to 0000 0F3C _H	—				Reserved
0000 0F40 _H	BT4TMR[R]H 00000000 00000000		BT4TMCR[R/W] B,H -00000000 00000000		Base timer ch.4
0000 0F44 _H	—	BT4STC[R/W]B 0000-000	—		
0000 0F48 _H	BT4PCSR/BT4PRLL[R/W]H XXXXXXXX XXXXXXXX		BT4PDUT/BT4PRLH/BT4DTBF[R/W]H XXXXXXXX XXXXXXXX		
0000 0F4C _H	—				
0000 0F50 _H	BT5TMR[R]H 00000000 00000000		BT5TMCR[R/W] B,H -00000000 00000000		Base timer ch.5
0000 0F54 _H	—	BT5STC[R/W]B 0000-000	—		
0000 0F58 _H	BT5PCSR/BT5PRLL[R/W]H XXXXXXXX XXXXXXXX		BT5PDUT/BT5PRLH/BT5DTBF[R/W]H XXXXXXXX XXXXXXXX		
0000 0F5C _H	—				
0000 0F60 _H	BT6TMR[R]H 00000000 00000000		BT6TMCR[R/W] B,H -00000000 00000000		Base timer ch.6
0000 0F64 _H	—	BT6STC[R/W]B 0000-000	—		
0000 0F68 _H	BT6PCSR/BT6PRLL[R/W]H XXXXXXXX XXXXXXXX		BT6PDUT/BT6PRLH/BT6DTBF[R/W]H XXXXXXXX XXXXXXXX		
0000 0F6C _H	—				
0000 0F70 _H	BT7TMR[R]H 00000000 00000000		BT7TMCR[R/W] B,H -00000000 00000000		Base timer ch.7
0000 0F74 _H	—	BT7STC[R/W]B 0000-000	—		
0000 0F78 _H	BT7PCSR/BT7PRLL[R/W]H XXXXXXXX XXXXXXXX		BT7PDUT/BT7PRLH/BT7DTBF[R/W]H XXXXXXXX XXXXXXXX		
0000 0F7C _H	BTSEL4567 [R/W] B 00000000	—			
0000 0F80 _H	BT8TMR[R]H 00000000 00000000		BT8TMCR[R/W] B,H -00000000 00000000		Base timer ch.8
0000 0F84 _H	—	BT8STC[R/W]B 0000-000	—		
0000 0F88 _H	BT8PCSR/BT8PRLL[R/W]H XXXXXXXX XXXXXXXX		BT8PDUT/BT8PRLH/BT8DTBF[R/W]H XXXXXXXX XXXXXXXX		
0000 0F8C _H	—				

(Continued)

MB91660 Series

Address	Register				Block
	+ 0	+ 1	+ 2	+ 3	
0000 0F90 _H	BT9TMR[R]H 00000000 00000000		BT9TMCR[R/W] B,H -00000000 00000000		Base timer ch.9
0000 0F94 _H	—	BT9STC[R/W]B 0000-000	—		
0000 0F98 _H	BT9PCSR/BT9PRL[R/W]H XXXXXXXX XXXXXXXX		BT9PDUT/BT9PRLH/BT9DTBF[R/W]H XXXXXXXX XXXXXXXX		
0000 0F9C _H	—				
0000 0FA0 _H	BTATMR[R]H 00000000 00000000		BTATMCR[R/W] B,H -00000000 00000000		Base timer ch.10
0000 0FA4 _H	—	BTA _{STC} [R/W]B 0000-000	—		
0000 0FA8 _H	BTA _{PCSR} /BTA _{PRL} [R/W]H XXXXXXXX XXXXXXXX		BTA _{PDUT} /BTA _{PRLH} /BTA _{DTBF} [R/W]H XXXXXXXX XXXXXXXX		
0000 0FAC _H	—				
0000 0FB0 _H	BTBTMR[R]H 00000000 00000000		BTBTMCR[R/W] B,H -00000000 00000000		Base timer ch.11
0000 0FB4 _H	—	BTB _{STC} [R/W]B 0000-000	—		
0000 0FB8 _H	BTB _{PCSR} /BTB _{PRL} [R/W]H XXXXXXXX XXXXXXXX		BTB _{PDUT} /BTB _{PRLH} /BTB _{DTBF} [R/W]H XXXXXXXX XXXXXXXX		
0000 0FBC _H	BTSEL89AB [R/W] B 00000000	—			
0000 0FC0 _H	BTCTMR[R]H 00000000 00000000		BTCTMCR[R/W] B,H -00000000 00000000		Base timer ch.12
0000 0FC4 _H	—	BTC _{STC} [R/W]B 0000-000	—		
0000 0FC8 _H	BTC _{PCSR} /BTC _{PRL} [R/W]H XXXXXXXX XXXXXXXX		BTC _{PDUT} /BTC _{PRLH} /BTC _{DTBF} [R/W]H XXXXXXXX XXXXXXXX		
0000 0FCC _H	—				
0000 0FD0 _H	BTD _{TMR} [R]H 00000000 00000000		BTD _{TMCR} [R/W] B,H -00000000 00000000		Base timer ch.13
0000 0FD4 _H	—	BTD _{STC} [R/W]B 0000-000	—		
0000 0FD8 _H	BTD _{PCSR} /BTD _{PRL} [R/W]H XXXXXXXX XXXXXXXX		BTD _{PDUT} /BTD _{PRLH} /BTD _{DTBF} [R/W]H XXXXXXXX XXXXXXXX		
0000 0FDC _H	—				

(Continued)

MB91660 Series

Address	Register				Block
	+ 0	+ 1	+ 2	+ 3	
0000 0FE0 _H	BTETMR[R]H 00000000 00000000		BTETMCR[R/W] B,H -0000000 00000000		Base timer ch.14
0000 0FE4 _H	—	BTESTC[R/W]B 0000-000	—		
0000 0FE8 _H	BTEPCSR/BTEPRLL[R/W]H XXXXXXXX XXXXXXXXX		BTEPDUT/BTEPRLLH/BTEDTBF [R/W]H XXXXXXXX XXXXXXXXX		
0000 0FEC _H	—				
0000 0FF0 _H	BTFTMR[R]H 00000000 00000000		BTFTMCR[R/W] B,H -0000000 00000000		Base timer ch.15
0000 0FF4 _H	—	BTFSTC[R/W]B 0000-000	—		
0000 0FF8 _H	BTFPCSR/BTFPRLL[R/W]H XXXXXXXX XXXXXXXXX		BTFPDUT/BTFPRLLH/BTFDFTBF [R/W]H XXXXXXXX XXXXXXXXX		
0000 0FFC _H	BTSELCDEF [R/W] B 00000000	—	BTSSSR [W] H XXXXXXXX XXXXXXXXX		
0000 1000 _H to 0000 20FC _H	—				Reserved
0000 2100 _H	HCNT1[R/W] B,H ----- 001	HCNT0[R/W] B,H 00000000	—		USB function / HOST
0000 2104 _H	HERR[R/W] B,H 00000011	HIRQ[R/W] B,H 0- 000000	—		
0000 2108 _H	HFCOMP[R/W] B,H 00000000	HSTATE[R,R/W] B,H --- 10010	—		
0000 210C _H	HRTIMER1[R/W] B,H 00000000	HRTIMER0[R/W] B,H 00000000	—		
0000 2110 _H	HADR[R/W] B,H - 0000000	HRTIMER2[R/W] B,H ----- 00	—		
0000 2114 _H	HEOF1[R/W] B,H -- 000000	HEOF0[R/W] B,H 00000000	—		
0000 2118 _H	HFRAME1[R/W] B,H ----- 000	HFRAME0[R/W] B,H 00000000	—		
0000 211C _H	—	HTOKEN[R/W] B 00000000	—		

(Continued)

MB91660 Series

Address	Register				Block
	+ 0	+ 1	+ 2	+ 3	
0000 2120 _H	—	UDCC[R/W] B 1010- - 00	—	—	USB function / HOST
0000 2124 _H	EP0C[R/W] H ----- 0- - 1000000		—	—	
0000 2128 _H	EP1C[R/W] H 01100001 00000000		—	—	
0000 212C _H	EP2C[R/W] H 0110000 - - 1000000		—	—	
0000 2130 _H	EP3C[R/W] H 0110000 - - 1000000		—	—	
0000 2134 _H	EP4C[R/W] H 0110000 - - 1000000		—	—	
0000 2138 _H	EP5C[R/W] H 0110000 - - 1000000		—	—	
0000 213C _H	TMSP[R] H ----- 000 00000000		—	—	
0000 2140 _H	UDCIE[R,R/W] B,H -- 000000	UDCS[R/W] B,H -- 000000	—	—	
0000 2144 _H	EP0IS[R/W] H 10- - - 1- - - - - - - - -		—	—	
0000 2148 _H	EP00S[R,R/W] H 100- - 00- - XXXXXXXX		—	—	
0000 214C _H	EP1S[R,R/W] H 100- 000X XXXXXXXXX		—	—	
0000 2150 _H	EP2S[R,R/W] H 100- 000- - XXXXXXXX		—	—	
0000 2154 _H	EP3S[R,R/W] H 100- 000- - XXXXXXXX		—	—	
0000 2158 _H	EP4S[R,R/W] H 100- 000- - XXXXXXXX		—	—	
0000 215C _H	EP5S[R,R/W] H 100- 000- - XXXXXXXX		—	—	
0000 2160 _H	EP0DTH [R/W] B,H XXXXXXXXXX	EP0DTL [R/W] B,H XXXXXXXXXX	—	—	
0000 2164 _H	EP1DTH [R/W] B,H XXXXXXXXXX	EP1DTL [R/W] B,H XXXXXXXXXX	—	—	
0000 2168 _H	EP2DTH [R/W] B,H XXXXXXXXXX	EP2DTL [R/W] B,H XXXXXXXXXX	—	—	
0000 216C _H	EP3DTH [R/W] B,H XXXXXXXXXX	EP3DTL [R/W] B,H XXXXXXXXXX	—	—	
0000 2170 _H	EP4DTH [R/W] B,H XXXXXXXXXX	EP4DTL [R/W] B,H XXXXXXXXXX	—	—	

(Continued)

(Continued)

Address	Register				Block
	+ 0	+ 1	+ 2	+ 3	
0000 2174 _H	EP5DTH [R/W] B,H XXXXXXXX	EP5DTL [R/W] B,H XXXXXXXX	—		USB function / HOST
0000 2178 _H to 0000 217C _H	—				
0000 2180 _H	SLIFRXDR [R] W 00000000 00000000 00000000 00000000				Slave interface
0000 2184 _H	SLIFTXDR [W] W 00000000 00000000 00000000 00000000				
0000 2188 _H	SLIFRXR[R] W 00000000 00000000 - - - - -				
0000 218C _H	SLIFTXR[W] W 00000000 00000000 - - - - -				
0000 2190 _H	SLIFCR[W] W - - - - - 0 00000000				
0000 2194 _H	SLIFSR[R] W - - - - - 00000000				
0000 2198 _H	SLIFRXSR[R] W 00000000 00000000 00000000 00000000				
0000 219C _H	SLIFTXSR[R] W 00000000 00000000 - - - - -				
0000 21A0 _H	SLIFDRXR[R] W 00000000 00000000 00000000 00000000				
0000 21A4 _H	DREQSEL [R/W] B,H 00111011	USBSEL [R/W] B,H - - - - - 0	USBEN [R/W] B - - - - - 0	—	
0000 21A8 _H to 0000 FFFC _H	—				Reserved

*1 : Byte access is available only when accessing the lower 8 bits within 9 bits.

*2 : The register of I²C can not be read immediate after reset.

*3 : Value just after reset by $\overline{\text{INIT}}$ pin.

Do not access the reserved areas.

MB91660 Series

■ VECTOR TABLE

Interrupt source (Peripheral resource)	Interrupt number		Interrupt level setting register	Offset	Address of TBR default
	Decimal	Hexa-decimal			
Reset	0	00	—	3FC _H	000F FFFC _H
System reserved	1	01	—	3F8 _H	000F FFF8 _H
System reserved	2	02	—	3F4 _H	000F FFF4 _H
System reserved	3	03	—	3F0 _H	000F FFF0 _H
System reserved	4	04	—	3EC _H	000F FFE _C _H
System reserved	5	05	—	3E8 _H	000F FFE8 _H
System reserved	6	06	—	3E4 _H	000F FFE4 _H
System reserved	7	07	—	3E0 _H	000F FFE0 _H
System reserved	8	08	—	3DC _H	000F FFDC _H
INTE instruction	9	09	—	3D8 _H	000F FFD8 _H
System reserved	10	0A	—	3D4 _H	000F FFD4 _H
System reserved	11	0B	—	3D0 _H	000F FFD0 _H
Step trace trap	12	0C	—	3CC _H	000F FFCC _H
System reserved	13	0D	—	3C8 _H	000F FFC8 _H
Undefined instruction exception	14	0E	—	3C4 _H	000F FFC4 _H
—	15	0F	15(F _H) fixed	3C0 _H	000F FFC0 _H
External interrupt request ch.0 to ch.7	16	10	ICR00	3BC _H	000F FFBC _H
External interrupt request ch.8 to ch.15	17	11	ICR01	3B8 _H	000F FFB8 _H
External interrupt request ch.16 to ch.23	18	12	ICR02	3B4 _H	000F FFB4 _H
External interrupt request ch.24 to ch.31	19	13	ICR03	3B0 _H	000F FF _B 0 _H
16-bit reload timer ch.0 to ch.2	20	14	ICR04	3AC _H	000F FFAC _H
Reception interrupt request of UART/CSIO ch.0	21	15	ICR05	3A8 _H	000F FFA8 _H
Transmission interrupt request of UART/CSIO ch.0 Transmission bus idle interrupt request of UART/CSIO ch.0	22	16	ICR06	3A4 _H	000F FFA4 _H
Reception interrupt request of UART/CSIO/ I ² C ch.1	23	17	ICR07	3A0 _H	000F FFA0 _H
Transmission interrupt request of UART/CSIO/ I ² C ch.1 Transmission bus idle interrupt request of UART/CSIO ch.1	24	18	ICR08	39C _H	000F FF9C _H
Status interrupt request of I ² C ch.1	25	19	ICR09	398 _H	000F FF98 _H
Reception interrupt request of UART/CSIO/I ² C ch.2	26	1A	ICR10	394 _H	000F FF94 _H
Transmission interrupt request of UART/CSIO/I ² C ch.2 Transmission bus idle interrupt request of UART/CSIO ch.2	27	1B	ICR11	390 _H	000F FF90 _H

(Continued)

Interrupt source (Peripheral resource)	Interrupt number		Interrupt level setting register	Offset	Address of TBR default
	Decimal	Hexa-decimal			
Status interrupt request of I ² C ch.2	28	1C	ICR12	38C _H	000F FF8C _H
Reception interrupt request of UART/CSIO/I ² C ch.3	29	1D	ICR13	388 _H	000F FF88 _H
Transmission interrupt request of UART/CSIO/I ² C ch.3. Transmission bus idle interrupt request of UART/CSIO ch.3. Status interrupt request of I ² C ch.3	30	1E	ICR14	384 _H	000F FF84 _H
Reception interrupt request of UART/CSIO/I ² C ch.4	31	1F	ICR15	380 _H	000F FF80 _H
Transmission interrupt request of UART/CSIO/I ² C ch.4. Transmission bus idle interrupt request of UART/CSIO ch.4. Status interrupt request of I ² C ch.4	32	20	ICR16	37C _H	000F FF7C _H
Reception interrupt request of UART/CSIO/I ² C ch.5	33	21	ICR17	378 _H	000F FF78 _H
Transmission interrupt request of UART/CSIO/I ² C ch.5. Transmission bus idle interrupt request of UART/CSIO ch.5. Status interrupt request of I ² C ch.5	34	22	ICR18	374 _H	000F FF74 _H
Reception interrupt request of UART/CSIO/ I ² C ch.6	35	23	ICR19	370 _H	000F FF70 _H
Transmission interrupt request of UART/CSIO/I ² C ch.6. Transmission bus idle interrupt request of UART/CSIO ch.6. Status interrupt request of I ² C ch.6	36	24	ICR20	36C _H	000F FF6C _H
Reception interrupt request of UART/CSIO/I ² C ch.7 32-bit input capture ch.4 to ch.7	37	25	ICR21	368 _H	000F FF68 _H
Transmission interrupt request of UART/CSIO/I ² C ch.7. Transmission bus idle interrupt request of UART/CSIO ch.7. Status interrupt request of I ² C ch.7 32-bit output compare ch.4 to ch.7	38	26	ICR22	364 _H	000F FF64 _H
Reception interrupt request of UART/CSIO/I ² C ch.8 to ch.11. Transmission interrupt request of UART/CSIO/I ² C ch.8 to ch.11. Transmission bus idle interrupt request of UART/CSIO ch.8 to ch.11. Transmission FIFO interrupt request UART/CSIO/I ² C ch.8 to ch.11 Status interrupt request of I ² C ch.8 to ch.11	39	27	ICR23	360 _H	000F FF60 _H
16-bit up/down counter ch.0 to ch.3	40	28	ICR24	35C _H	000F FF5C _H
Main timer/Sub timer/Watch counter	41	29	ICR25	358 _H	000F FF58 _H
10-bit A/D converter <ul style="list-style-type: none"> • Scan conversion interrupt request • Priority conversion interrupt request • FIFO overrun interrupt request • Conversion result compare interrupt request 	42	2A	ICR26	354 _H	000F FF54 _H
32-bit free-run timer ch.0, ch.1	43	2B	ICR27	350 _H	000F FF50 _H
32-bit input capture ch.0 to ch.3	44	2C	ICR28	34C _H	000F FF4C _H
32-bit output compare ch.0 to ch.3	45	2D	ICR29	348 _H	000F FF48 _H

(Continued)

MB91660 Series

(Continued)

Interrupt source (Peripheral resource)	Interrupt number		Interrupt level setting register	Offset	Address of TBR default
	Decimal	Hexadecimal			
Base timer ch.0	46	2E	ICR30	344 _H	000F FF44 _H
Base timer ch.1	47	2F	ICR31	340 _H	000F FF40 _H
Base timer ch.2	48	30	ICR32	33C _H	000F FF3C _H
Base timer ch.3	49	31	ICR33	338 _H	000F FF38 _H
Base timer ch.4, ch.5	50	32	ICR34	334 _H	000F FF34 _H
Base timer ch.6, ch.7	51	33	ICR35	330 _H	000F FF30 _H
Base timer ch.8, ch.9	52	34	ICR36	32C _H	000F FF2C _H
Base timer ch.10, ch.11	53	35	ICR37	328 _H	000F FF28 _H
Base timer ch.12/USB function (DRQ of End Point 1 to 5)	54	36	ICR38	324 _H	000F FF24 _H
Base timer ch.13/USB function (DRQI of End Point 0, DRQO and each status/ USB HOST (each status)	55	37	ICR39	320 _H	000F FF20 _H
Base timer ch.14, ch.15/Slave interface	56	38	ICR40	31C _H	000F FF1C _H
DMA controller (DMAC) ch.0	57	39	ICR41	318 _H	000F FF18 _H
DMA controller (DMAC) ch.1	58	3A	ICR42	314 _H	000F FF14 _H
DMA controller (DMAC) ch.2	59	3B	ICR43	310 _H	000F FF10 _H
DMA controller (DMAC) ch.3	60	3C	ICR44	30C _H	000F FF0C _H
DMA controller (DMAC) ch.4 to ch.7	61	3D	ICR45	308 _H	000F FF08 _H
System reserved	62	3E	ICR46	304 _H	000F FF04 _H
Delay interrupt	63	3F	ICR47	300 _H	000F FF00 _H
System reserved (Used by REALOS)	64	40	—	2FC _H	000F FEF C _H
System reserved (Used by REALOS)	65	41	—	2F8 _H	000F FEF 8 _H
Used by INT instruction	66 to 255	42 to FF	—	2F4 _H to 000 _H	000F FEF 4 _H to 000F FC00 _H

* : USB interrupt source

Number		USB interrupt source	Details
Decimal	Hexadecimal		
54	36	USB function (DRQ of End Point 1 to 5)	DRQ (End Point1 to 5)
55	37	USB function (DRQI, DRQO of End Point 0 and each status)	DRQI, DRQO, SPK, SUSP, SOF, BRST, CONF, WKUP
		USB HOST (Each status)	DIRQ, URIRQ, RWKIRQ, CNNIRQ, SOFIRQ, CMPIRQ

■ PIN STATUS IN EACH CPU STATE

- When $\overline{\text{INIT}} = \text{“L”}$

This is the period when the $\overline{\text{INIT}}$ pin is the “L” level.

- When $\overline{\text{INIT}} = \text{“H”}$

The status immediately after the $\overline{\text{INIT}}$ pin changes from the “L” level to the “H” level.

- SLVL1

This bit is a standby level setting bit in the standby mode control register (STBCR).

- Input enabled

Indicates that the input function can be used.

- Input disabled

Indicates that the input function cannot be used.

- Output Hi-Z

Indicates that the output drive transistor is disabled and the pin is put in the Hi-Z state.

- Maintain previous state

Maintains the state that was being output immediately prior to entering the current mode.
If a built-in peripheral function is operating, the output follows the peripheral function.
If the pin is being used as a port, that output is maintained.

- Internal input fixed at “0”

The input gate connected to the pin is disconnected from the external input and internally connected to “0”.

- Input enabled when interrupt function selected and enabled

Inputs are allowed only when the pin is configured as an external interrupt request input pin and the external interrupt request is enabled.

MB91660 Series

• List of pin status

Pin name	Function	During initialization		Sleep Mode	Standby Mode	
		$\overline{\text{INIT}} = \text{“L”}$	$\overline{\text{INIT}} = \text{“H”}$		SLVL1 = 0	SLVL1 = 1
$\overline{\text{INIT}}$	$\overline{\text{INIT}}$	—	—	Input enabled	Input enabled	Input enabled
X0	X0	Input enabled	Input enabled		Hi-Z or Input enabled	Hi-Z or Input enabled
X1	X1	Input enabled	Input enabled		“H” output or Input enabled	“H” output or Input enabled
X0A	X0A (When $\overline{\text{INIT}}$ input, see PK1. When port selected, input disabled)	Input disabled	Input disabled		Hi-Z or Input enabled	Hi-Z or Input enabled
X1A	X1A (When $\overline{\text{INIT}}$ input, see PK0. When port selected, input disabled)	Input disabled	Input disabled		“H” output or Input enabled	“H” output or Input enabled
MD0	MD0	Input enabled	Input enabled		Input enabled	Input enabled
MD1	MD1	Input enabled	Input enabled			
P00	P00/D00/TIOA0/SOUT0_1/IN0	Output Hi-Z	Output Hi-Z/ Input enabled		Maintain previous state	Maintain previous state
P01	P01/D01/TIOB0/SIN0_1/IN1					
P02	P02/D02/TIOA1/SCK0_1/IN2					
P03	P03/D03/TIOB1/IN3					
P04	P04/D04/TIOA2/SOUT1/IN4					
P05	P05/D05/TIOB2/SIN1/IN5					
P06	P06/D06/TIOA3/SCK1/IN6					
P07	P07/D07/TIOB3/IN7					

(Continued)

MB91660 Series

Pin name	Function	During initialization		Sleep Mode	Standby Mode	
		$\overline{\text{INIT}} = \text{"L"}$	$\overline{\text{INIT}} = \text{"H"}$		SLVL1 = 0	SLVL1 = 1
P10	P10/D08/TIOA4/SOUT2/AIN0/INT0	Output Hi-Z	Output Hi-Z/ Input enabled	Maintain previous state	Maintain previous state	Output Hi-Z/ Internal input fixed at "0" Input enabled when interrupt function selected and enabled
P11	P11/D09/TIOB4/SIN2/BIN0/INT1					
P12	P12/D10/TIOA5/SCK2/ZIN0/INT2					
P13	P13/D11/TIOB5/INT3					
P14	P14/D12/TIOA6/SOUT3/AIN1/INT4					
P15	P15/D13/TIOB6/SIN3/BIN1/INT5					
P16	P16/D14/TIOA7/SCK3/ZIN1/INT6					
P17	P17/D15/TIOB7/INT7					
P20	P20/A00/TIOA8/SOUT4/AIN2	Output Hi-Z	Output Hi-Z/ Input enabled	Maintain previous state	Maintain previous state	Output Hi-Z/ Internal input fixed at "0"
P21	P21/A01/TIOB8/SIN4/BIN2					
P22	P22/A02/TIOA9/SCK4/ZIN2/ SIFD0_1					
P23	P23/A03/TIOB9/SIFD1_1					
P24	P24/A04/TIOA10/SOUT5/AIN3/ OUT0/SIFD2_1					
P25	P25/A05/TIOB10/SIN5/BIN3/ OUT1/SIFD3_1					
P26	P26/A06/TIOA11/SCK5/ZIN3/ OUT2/SIFD4_1					
P27	P27/A07/TIOB11/OUT3/SIFD5_1					
P30	P30/A08/TIOA12/SOUT6/INT8/ SIFD6_1	Output Hi-Z	Output Hi-Z/ Input enabled	Maintain previous state	Maintain previous state	Output Hi-Z/ Internal input fixed at "0" Input enabled when interrupt function selected and enabled
P31	P31/A09/TIOB12/SIN6/INT9/ SIFD7_1					
P32	P32/A10/TIOA13/SCK6/INT10/ SIFD8_1					
P33	P33/A11/TIOB13/INT11/SIFD9_1					
P34	P34/A12/TIOA14/SOUT7/OUT4/ INT12/SIFD10_1					
P35	P35/A13/TIOB14/SIN7/OUT5/ INT13/SIFD11_1					
P36	P36/A14/TIOA15/SCK7/OUT6/ INT14/SIFD12_1					
P37	P37/A15/TIOB15/OUT7/INT15/ SIFD13_1					

(Continued)

MB91660 Series

Pin name	Function	During initialization		Sleep Mode	Standby Mode	
		$\overline{\text{INIT}} = \text{“L”}$	$\overline{\text{INIT}} = \text{“H”}$		SLVL1 = 0	SLVL1 = 1
P40	P40/A16/SOUT8/SIFD14_1	Output Hi-Z	Output Hi-Z/ Input enabled	Maintain previous state	Maintain previous state	Output Hi-Z/ Internal input fixed at “0”
P41	P41/A17/SIN8/SIFD15_1					
P42	P42/A18/SCK8/SIFCS_1					
P43	P43/A19/SIFA_1					
P44	P44/A20/SOUT9/SIFWR_1					
P45	P45/A21/SIN9/SIFRD_1					
P46	P46/A22/SCK9/SIFDRQR_1					
P47	P47/A23/SIFDRQT_1					
P50	P50/CS0/SOUT10/AIN0_1	Output Hi-Z	Output Hi-Z/ Input enabled	Maintain previous state	Maintain previous state	Output Hi-Z/ Internal input fixed at “0”
P51	P51/ $\overline{\text{CS1}}$ /SIN10/BIN0_1					
P52	P52/ $\overline{\text{CS2}}$ /SCK10/ZIN0_1					
P53	P53/ $\overline{\text{CS3}}$ /FRCK1/INT21_2					Input enabled when interrupt function selected and enabled
P54	P54/ $\overline{\text{AS}}$ /SOUT11/AIN1_1					
P55	P55/ $\overline{\text{RD}}$ /SIN11/BIN1_1/ADTRG0					
P56	P56/ $\overline{\text{WR0}}$ /SCK11/ZIN1_1/FRCK0					
P57	P57/ $\overline{\text{WR1}}$					
						Output Hi-Z/ Internal input fixed at “0”

(Continued)

MB91660 Series

Pin name	Function	During initialization		Sleep Mode	Standby Mode	
		$\overline{\text{INIT}} = \text{"L"}$	$\overline{\text{INIT}} = \text{"H"}$		SLVL1 = 0	SLVL1 = 1
P60	P60/RDY/AIN2_1	Output Hi-Z	Output Hi-Z/ Input enabled	Maintain previous state	Maintain previous state	Output Hi-Z/ Internal input fixed at "0"
P61	P61/SYSCLK/BIN2_1					
P62	P62/DREQ0/ZIN2_1					
P63	P63/DACK0/FRCK1_1/INT22_2					Input enabled when interrupt function selected and enabled
P64	P64/DEOP0/AIN3_1					
P65	P65/DREQ1/BIN3_1/ADTRG0_1					Output Hi-Z/ Internal input fixed at "0"
P66	P66/DACK1/ZIN3_1/FRCK0_1					
P67	P67/DEOP1/INT23_2	Output Hi-Z/ Internal input fixed at "0"	Input enabled when interrupt function selected and enabled			

(Continued)

MB91660 Series

Pin name	Function	During initialization		Sleep Mode	Standby Mode	
		$\overline{\text{INIT}} = \text{"L"}$	$\overline{\text{INIT}} = \text{"H"}$		SLVL1 = 0	SLVL1 = 1
P70	P70/AN0/OUT0_1/INT16	Output Hi-Z	Output Hi-Z/ Input disabled	Maintain previous state	Maintain previous state	Output Hi-Z/ Internal input fixed at "0" Input enabled when interrupt function selected and enabled
P71	P71/AN1/OUT1_1/INT17					
P72	P72/AN2/TMO0/OUT2_1/ INT18/SIFD0					
P73	P73/AN3/TMO1/OUT3_1/ INT19/SIFD1					
P74	P74/AN4/TMO2/OUT4_1/ INT20/SIFD2					
P75	P75/AN5/SOUT0/TMI0/ OUT5_1/INT21/SIFD3					
P76	P76/AN6/SIN0/TMI1/OUT6_1/ INT22/SIFD4					
P77	P77/AN7/SCK0/TMI2/OUT7_1/ INT23/SIFD5					
P80	P80/AN8/IN0_1/INT24/SIFD6	Output Hi-Z	Output Hi-Z/ Input disabled	Maintain previous state	Maintain previous state	Output Hi-Z/ Internal input fixed at "0" Input enabled when interrupt function selected and enabled
P81	P81/AN9/IN1_1/INT25/SIFD7					
P82	P82/AN10/IN2_1/INT26/SIFD8					
P83	P83/AN11/IN3_1/INT27/SIFD9					
P84	P84/AN12/IN4_1/INT28/SIFD10					
P85	P85/AN13/IN5_1/INT29/SIFD11					
P86	P86/AN14/IN6_1/INT30/SIFD12					
P87	P87/AN15/IN7_1/INT31/SIFD13					
P90	P90/DA0	Output Hi-Z	Output Hi-Z/ Input enabled	Maintain previous state	Maintain previous state	Output Hi-Z/ Internal input fixed at "0"
P91	P91/DA1					
P92	P92/DA2					

(Continued)

MB91660 Series

Pin name	Function	During initialization		Sleep Mode	Standby Mode	
		$\overline{\text{INIT}} = \text{“L”}$	$\overline{\text{INIT}} = \text{“H”}$		SLVL1 = 0	SLVL1 = 1
PA0	PA0/AN16/INT16_1/SIFD14	Output Hi-Z	Output Hi-Z/ Input disabled	Maintain previous state	Maintain previous state	Output Hi-Z/ Internal input fixed at “0” Input enabled when interrupt function selected and enabled
PA1	PA1/AN17/INT17_1/SIFD15					
PA2	PA2/AN18/TMO0_1/INT18_1/ $\overline{\text{SIFCS}}$					
PA3	PA3/AN19/TMO1_1/INT19_1/ $\overline{\text{SIFA}}$					
PA4	PA4/AN20/TMO2_1/INT20_1/ $\overline{\text{SIFWR}}$					
PA5	PA5/AN21/TMO0_1/INT21_1/ $\overline{\text{SIFRD}}$					
PA6	PA6/AN22/TMI1_1/INT22_1/ $\overline{\text{SIFDRQR}}$					
PA7	PA7/AN23/TMI2_1/INT23_1/ $\overline{\text{SIFDRQT}}$					
PG0	PG0/DREQ2/TIOA0_1/SOUT0_2/ IN0_2	Output Hi-Z	Output Hi-Z/ Input enabled	Maintain previous state	Maintain previous state	Output Hi-Z/ Internal input fixed at “0”
PG1	PG1/DACK2/TIOB0_1/SIN0_2/ IN1_2					
PG2	PG2/DEOP2/TIOA1_1/SCK0_2/ IN2_2					
PG3	PG3/DREQ3/TIOB1_1/IN3_2					
PG4	PG4/DACK3/TIOA2_1/SOUT1_1/ IN4_2					
PG5	PG5/DEOP3/TIOB2_1/SIN1_1/ IN5_2					
PG6	PG6/TIOA3_1/SCK1_1/IN6_2					
PG7	PG7/TIOB3_1/IN7_2					
PH0	PH0/TIOA4_1/SOUT2_1/AIN0_2/ INT0_1	Output Hi-Z	Output Hi-Z/ Input enabled	Maintain previous state	Maintain previous state	Output Hi-Z/ Internal input fixed at “0” Input enabled when interrupt function selected and enabled
PH1	PH1/TIOB4_1/SIN2_1/BIN0_2/ INT1_1					
PH2	PH2/TIOA5_1/SCK2_1/ZIN0_2/ INT2_1					
PH3	PH3/TIOB5_1/INT3_1					

(Continued)

MB91660 Series

(Continued)

Pin name	Function	During initialization		Sleep Mode	Standby Mode	
		$\overline{\text{INIT}} = \text{"L"}$	$\overline{\text{INIT}} = \text{"H"}$		SLVL1 = 0	SLVL1 = 1
PK0	PK0	Output Hi-Z	Output Hi-Z/ Internal input fixed at "0"	Maintain previous state	Maintain previous state	Output Hi-Z/ Internal input fixed at "0"
PK1	PK1					
PK2	PK2/ADTRG0_2					
PK3	PK3/ADTRG0_3		Output Hi-Z/ Input enabled			
UDP	UDP (USB)	Output Hi-Z	Output Hi-Z/ Input enabled	Maintain previous state/Input enabled	Maintain previous state	Maintain previous state
UDM	UDM (USB)					

MB91660 Series

- List of pin status (serial write mode)

Pin name	Function	During initialization	During asynchronous write operation	During synchronous write operation
		$\overline{\text{INIT}} = \text{“L”}$	$\overline{\text{INIT}} = \text{“H”}$	
$\overline{\text{INIT}}$	$\overline{\text{INIT}}$	—	—	—
X0	X0	Input enabled	Input enabled	Input enabled
X1	X1	Input enabled	Input enabled	Input enabled
X0A	X0A (When $\overline{\text{INIT}}$ input, see PK1. When port selected, input disabled)	Input disabled	Input disabled	Input disabled
X1A	X1A (When $\overline{\text{INIT}}$ input, see PK0. When port selected, input disabled)	Input disabled	Input disabled	Input disabled
MD0	MD0	Input enabled	Input enabled	Input enabled
MD1	MD1	Input enabled	Input enabled	Input enabled
P00	P00/D00/TIOA0/SOUT0_1/ IN0	Output Hi-Z	Output Hi-Z/ Input enabled	Output Hi-Z/ Input enabled
P01	P01/D01/TIOB0/SIN0_1/IN1			
P02	P02/D02/TIOA1/SCK0_1/IN2			
P03	P03/D03/TIOB1/IN3			
P04	P04/D04/TIOA2/SOUT1/IN4			
P05	P05/D05/TIOB2/SIN1/IN5			
P06	P06/D06/TIOA3/SCK1/IN6			
P07	P07/D07/TIOB3/IN7			
P10	P10/D08/TIOA4/SOUT2/AIN0/ INT0	Output Hi-Z	Output Hi-Z/ Input enabled	Output Hi-Z/ Input enabled
P11	P11/D09/TIOB4/SIN2/BIN0/ INT1			
P12	P12/D10/TIOA5/SCK2/ZIN0/ INT2			
P13	P13/D11/TIOB5/INT3			
P14	P14/D12/TIOA6/SOUT3/AIN1/ INT4			
P15	P15/D13/TIOB6/SIN3/BIN1/ INT5			
P16	P16/D14/TIOA7/SCK3/ZIN1/ INT6			
P17	P17/D15/TIOB7/INT7			

(Continued)

MB91660 Series

Pin name	Function	During initialization	During asynchronous write operation	During synchronous write operation
		$\overline{\text{INIT}} = \text{“L”}$	$\overline{\text{INIT}} = \text{“H”}$	
P20	P20/A00/TIOA8/SOUT4/AIN2	Output Hi-Z	Output Hi-Z/ Input enabled	Output Hi-Z/ Input enabled
P21	P21/A01/TIOB8/SIN4/BIN2			
P22	P22/A02/TIOA9/SCK4/ZIN2/ SIFD0_1			
P23	P23/A03/TIOB9/SIFD1_1			
P24	P24/A04/TIOA10/SOUT5/ AIN3/OUT0/SIFD2_1			
P25	P25/A05/TIOB10/SIN5/BIN3/ OUT1/SIFD3_1			
P26	P26/A06/TIOA11/SCK5/ZIN3/ OUT2/SIFD4_1			
P27	P27/A07/TIOB11/OUT3/ SIFD5_1			
P30	P30/A08/TIOA12/SOUT6/ INT8/SIFD6_1	Output Hi-Z	Output Hi-Z/ Input enabled	Output Hi-Z/ Input enabled
P31	P31/A09/TIOB12/SIN6/INT9/ SIFD7_1			
P32	P32/A10/TIOA13/SCK6/ INT10/SIFD8_1			
P33	P33/A11/TIOB13/INT11/ SIFD9_1			
P34	P34/A12/TIOA14/SOUT7/ OUT4/INT12/SIFD10_1			
P35	P35/A13/TIOB14/SIN7/OUT5/ INT13/SIFD11_1			
P36	P36/A14/TIOA15/SCK7/ OUT6/INT14/SIFD12_1			
P37	P37/A15/TIOB15/OUT7/ INT15/SIFD13_1			
P40	P40/A16/SOUT8/SIFD14_1	Output Hi-Z	Output Hi-Z/ Input enabled	Output Hi-Z/ Input enabled
P41	P41/A17/SIN8/SIFD15_1			
P42	P42/A18/SCK8/SIFCS_1			
P43	P43/A19/SIFA_1			
P44	P44/A20/SOUT9/SIFWR_1			
P45	P45/A21/SIN9/SIFRD_1			
P46	P46/A22/SCK9/SIFDRQR_1			
P47	P47/A23/SIFDRQT_1			

(Continued)

MB91660 Series

Pin name	Function	During initialization	During asynchronous write operation	During synchronous write operation
		$\overline{\text{INIT}} = \text{"L"}$	$\overline{\text{INIT}} = \text{"H"}$	
P50	P50/ $\overline{\text{CS0}}$ /SOUT10/AIN0_1	Output Hi-Z	Output Hi-Z/ Input enabled	Output Hi-Z/ Input enabled
P51	P51/ $\overline{\text{CS1}}$ /SIN10/BIN0_1			
P52	P52/ $\overline{\text{CS2}}$ /SCK10/ZIN0_1			
P53	P53/ $\overline{\text{CS3}}$ /FRCK1/INT21_2			
P54	P54/ $\overline{\text{AS}}$ /SOUT11/AIN1_1			
P55	P55/ $\overline{\text{RD}}$ /SIN11/BIN1_1/ ADTRG0			
P56	P56/ $\overline{\text{WR0}}$ /SCK11/ZIN1_1/ FRCK0			
P57	P57/ $\overline{\text{WR1}}$			
P60	P60/RDY/AIN2_1	Output Hi-Z	Output Hi-Z/ Input enabled	Output Hi-Z/ Input enabled
P61	P61/SYSCLK/BIN2_1			
P62	P62/DREQ0/ZIN2_1			
P63	P63/DACK0/FRCK1_1/ INT22_2			
P64	P64/DEOP0/AIN3_1			
P65	P65/DREQ1/BIN3_1/ ADTRG0_1			
P66	P66/DACK1/ZIN3_1/ FRCK0_1			
P67	P67/DEOP1/INT23_2			
P70	P70/AN0/OUT0_1/INT16	Output Hi-Z	Output Hi-Z/ Input disabled	Output Hi-Z/ Input disabled
P71	P71/AN1/OUT1_1/INT17			
P72	P72/AN2/TMO0/OUT2_1/ INT18/SIFD0			
P73	P73/AN3/TMO1/OUT3_1/ INT19/SIFD1			
P74	P74/AN4/TMO2/OUT4_1/ INT20/SIFD2			
P75	P75/AN5/SOUT0/TMI0/ OUT5_1/INT21/SIFD3	Output Hi-Z/ Input enabled	Output	Output
P76	P76/AN6/SIN0/TMI1/OUT6_1/ INT22/SIFD4	Output Hi-Z	Output Hi-Z/ Input enabled	Output Hi-Z/ Input enabled
P77	P77/AN7/SCK0/TMI2/ OUT7_1/INT23/SIFD5		Output Hi-Z/ Input disabled	Output Hi-Z/ Input enabled

(Continued)

MB91660 Series

Pin name	Function	During initialization	During asynchronous write operation	During synchronous write operation
		$\overline{\text{INIT}} = \text{"L"}$	$\overline{\text{INIT}} = \text{"H"}$	
P80	P80/AN8/IN0_1/INT24/SIFD6	Output Hi-Z	Output Hi-Z/ Input disabled	Output Hi-Z/ Input disabled
P81	P81/AN9/IN1_1/INT25/SIFD7			
P82	P82/AN10/IN2_1/INT26/SIFD8			
P83	P83/AN11/IN3_1/INT27/SIFD9			
P84	P84/AN12/IN4_1/INT28/SIFD10			
P85	P85/AN13/IN5_1/INT29/SIFD11			
P86	P86/AN14/IN6_1/INT30/SIFD12			
P87	P87/AN15/IN7_1/INT31/SIFD13			
P90	P90/DA0	Output Hi-Z	Output Hi-Z/ Input enabled	Output Hi-Z/ Input enabled
P91	P91/DA1			
P92	P92/DA2			
PA0	PA0/AN16/INT16_1/SIFD14	Output Hi-Z	Output Hi-Z/ Input disabled	Output Hi-Z/ Input disabled
PA1	PA1/AN17/INT17_1/SIFD15			
PA2	PA2/AN18/TMO0_1/INT18_1/ SIFCS			
PA3	PA3/AN19/TMO1_1/INT19_1/ SIFA			
PA4	PA4/AN20/TMO2_1/INT20_1/ SIFWR			
PA5	PA5/AN21/TMI0_1/INT21_1/ SIFRD			
PA6	PA6/AN22/TMI1_1/INT22_1/ SIFDRQR			
PA7	PA7/AN23/TMI2_1/INT23_1/ SIFDRQT			

(Continued)

MB91660 Series

(Continued)

Pin name	Function	During initialization	During asynchronous write operation	During synchronous write operation
		$\overline{\text{INIT}} = \text{"L"}$	$\overline{\text{INIT}} = \text{"H"}$	
PG0	PG0/DREQ2/TIOA0_1/ SOUT0_2/IN0_2	Output Hi-Z	Output Hi-Z/ Input enabled	Output Hi-Z/ Input enabled
PG1	PG1/DACK2/TIOB0_1/ SIN0_2/IN1_2			
PG2	PG2/DEOP2/TIOA1_1/ SCK0_2/IN2_2			
PG3	PG3/DREQ3/TIOB1_1/IN3_2			
PG4	PG4/DACK3/TIOA2_1/ SOUT1_1/IN4_2			
PG5	PG5/DEOP3/TIOB2_1/ SIN1_1/IN5_2			
PG6	PG6/TIOA3_1/SCK1_1/IN6_2			
PG7	PG7/TIOB3_1/IN7_2			
PH0	PH0/TIOA4_1/SOUT2_1/ AIN0_2/INT0_1	Output Hi-Z	Output Hi-Z/ Input enabled	Output Hi-Z/ Input enabled
PH1	PH1/TIOB4_1/SIN2_1/ BIN0_2/INT1_1			
PH2	PH2/TIOA5_1/SCK2_1/ ZIN0_2/INT2_1			
PH3	PH3/TIOB5_1/INT3_1			
PK0	PK0	Output Hi-Z	Output Hi-Z/ Input enabled	Output Hi-Z/ Input enabled
PK1	PK1			
PK2	PK2/ADTRG0_2			
PK3	PK3/ADTRG0_3			
UDP	UDP (USB)	Output Hi-Z	Output Hi-Z/ Input enabled	Output Hi-Z/ Input enabled
UDM	UDM (USB)			

MB91660 Series

■ ELECTRICAL CHARACTERISTICS

1. Absolute Maximum Ratings

Parameter	Symbol	Rating		Unit	Remarks
		Min	Max		
Power supply voltage*1, *2	V_{CC}	$V_{SS} - 0.3$	$V_{SS} + 4.0$	V	
Analog power supply voltage*1, *3	AV_{CC}	$V_{SS} - 0.3$	$V_{SS} + 4.0$	V	
Analog reference voltage*1, *3	AV_{RH}	$V_{SS} - 0.3$	$V_{SS} + 4.0$	V	
Input voltage*1	V_I	$V_{SS} - 0.3$	$V_{CC} + 0.3$ (≤ 4.0)	V	*7
		$V_{SS} - 0.3$	$V_{SS} + 6.0$	V	5 V tolerant
		$V_{SS} - 0.5$	$V_{SS} + 4.5$	V	USB I/O
Analog pin input voltage*1	V_{IA}	$V_{SS} - 0.3$	$V_{SS} + 4.0$	V	
Output voltage*1	V_O	$V_{SS} - 0.3$	$V_{CC} + 0.3$	V	
		$V_{SS} - 0.5$	$V_{SS} + 4.5$	V	USB I/O
Maximum clamp current	I_{CLAMP}	- 4	+ 4	mA	*8
Total maximum clamp current	$\Sigma I_{CLAMP} $	—	40	mA	*8
“L” level maximum output current*4	I_{OL}	—	10	mA	
		—	43	mA	USB I/O
“L” level average output current*5	I_{OLAV}	—	4	mA	
		—	15	mA	USB I/O
“L” level total maximum output current	ΣI_{OL}	—	100	mA	
“L” level total average output current*6	ΣI_{OLAV}	—	50	mA	
“H” level maximum output current*4	I_{OH}	—	- 10	mA	
		—	- 43	mA	USB I/O
“H” level average output current*5	I_{OHAV}	—	- 4	mA	
		—	- 15	mA	USB I/O
“H” level total maximum output current*6	ΣI_{OH}	—	- 100	mA	
“H” level total average output current	ΣI_{OHAV}	—	- 50	mA	
Power consumption (Flash product)	P_D	—	500	mW	
Power consumption (MASK product)	P_D	—	350	mW	
Operating temperature	T_a	- 40	+ 85	°C	
Storage temperature	T_{STG}	- 55	+ 125	°C	

*1 : The parameter is based on $V_{SS} = AV_{SS} = 0.0$ V.

*2 : V_{CC} must not drop below $V_{SS} - 0.3$ V.

*3 : Be careful not to exceed $V_{CC} + 0.3$ V, for example, when the power is turned on.

*4 : The maximum output current is the peak value for a single pin.

*5 : The average output is the average current for a single pin over a period of 100 ms.

(Continued)

(Continued)

- *6 : The total average output current is the average current for all pins over a period of 100 ms.
- *7 : If the input current or the maximum input current are limited by some means with external components, the I_{CLAMP} rating supersedes the V_I rating.
- *8 :
 - Corresponding pins: P14 to P17, P50 to P57, P60 to P62, P67, PK2, PK3
 - Use within recommended operating conditions.
 - Use at DC voltage (current).
 - The +B signal should always be applied by connecting a limiting resistor between the +B signal and the microcontroller.
 - The value of the limiting resistor should be set so that the current input to the microcontroller pin does not exceed rated values at any time regardless of instantaneously or constantly when the +B signal is input.
 - Note that when the microcontroller drive current is low, such as in the low power consumption modes, the +B input potential can increase the potential at the V_{CC} pin via a protective diode, possibly affecting other devices.
 - Note that if the +B signal is input when the microcontroller is off (not fixed at 0V), since the power is supplied through the pin, the microcontroller may operate incompletely.
 - Do not leave +B input pins open.
 - Sample recommended circuit

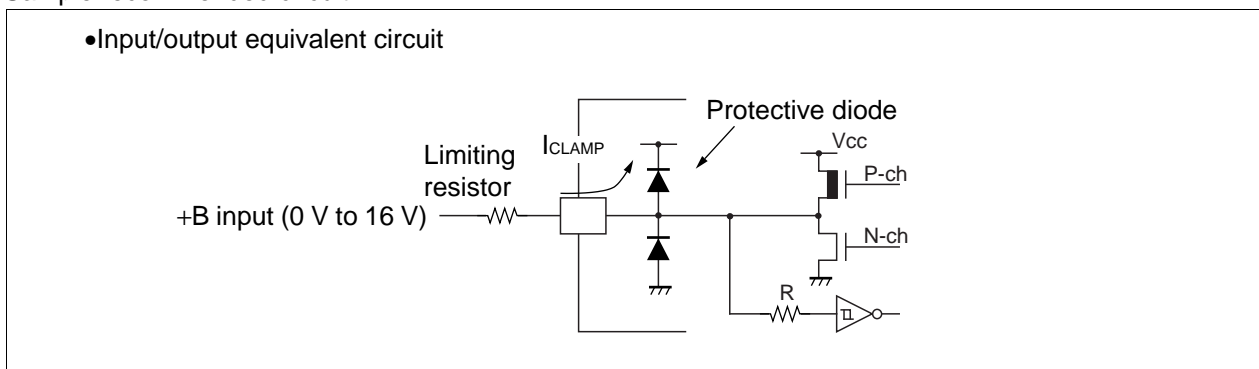

WARNING: Semiconductor devices can be permanently damaged by application of stress (voltage, current, temperature, etc.) in excess of absolute maximum ratings. Do not exceed these ratings.

MB91660 Series

2. Recommended Operating Conditions

($V_{SS} = AV_{SS} = 0.0\text{ V}$)

Parameter	Symbol	Value		Unit	Remarks
		Min	Max		
Power supply voltage	V_{CC}	2.7	3.6	V	Not using USB
		3.0	3.6	V	Using USB
Analog power supply voltage	AV_{CC}	2.7	3.6	V	Not using USB
		3.0	3.6	V	Using USB
Analog reference voltage	AV_{RH}	AV_{SS}	AV_{CC}	V	
Operating temperature	T_a	- 40	+ 85	°C	

WARNING: The recommended operating conditions are required in order to ensure the normal operation of the semiconductor device. All of the device's electrical characteristics are warranted when the device is operated within these ranges.

Always use semiconductor devices within their recommended operating condition ranges. Operation outside these ranges may adversely affect reliability and could result in device failure.

No warranty is made with respect to uses, operating conditions, or combinations not represented on the data sheet. Users considering application outside the listed conditions are advised to contact their representatives beforehand.

3. DC Characteristics

(1) DC Characteristics

Not using USB : ($V_{CC} = AV_{CC} = 2.7 \text{ V to } 3.6 \text{ V}$, $V_{SS} = AV_{SS} = 0 \text{ V}$, $T_a = -40 \text{ }^\circ\text{C to } +85 \text{ }^\circ\text{C}$)

Using USB : ($V_{CC} = AV_{CC} = 3.0 \text{ V to } 3.6 \text{ V}$, $V_{SS} = AV_{SS} = 0 \text{ V}$, $T_a = -40 \text{ }^\circ\text{C to } +85 \text{ }^\circ\text{C}$)

Parameter	Symbol	Pin name	Conditions	Value			Unit	Remarks
				Min	Typ	Max		
Power supply current (Flash product)	I _{CC}	V _{CC}	Normal operation	—	45	60	mA	CPU : 33 MHz, Peripheral : 33 MHz, Not using USB*1, *3
				—	55	75	mA	CPU : 32 MHz, Peripheral : 32 MHz, Using USB*1, *3
	SLEEP mode		—	15	25	mA	Peripheral : 33 MHz, Not using USB*1, *3	
			—	25	40	mA	Peripheral : 32 MHz Using USB*1, *3	
	I _{CCS}		Sub operation	—	100	500	μA	CPU : 32 kHz, Peripheral : 32 kHz *1, *2, *4
	I _{CCCL}			Watch mode	—	70	400	μA
I _{CCCT}	STOP mode	—	45	300	μA	*1, *2		
Power supply current (MASK product)	I _{CC}	V _{CC}	Normal operation	—	25	40	mA	CPU:33 MHz, Peripheral : 33 MHz, Not using USB*1, *3
				—	35	55	mA	CPU:32 MHz, Peripheral : 32 MHz, Using USB*1, *3
	SLEEP mode		—	15	25	mA	Peripheral : 33 MHz, Not using USB*1, *3	
			—	25	40	mA	Peripheral : 32 MHz, Using USB*1, *3	
	I _{CCS}		Sub operation	—	100	500	μA	CPU:32 kHz, Peripheral : 32 kHz *1, *2, *4
	I _{CCCL}			Watch mode	—	70	400	μA
I _{CCCT}	STOP mode	—	45	300	μA	*1, *2		
I _{CCCH}								

(Continued)

MB91660 Series

Parameter	Sym- bol	Pin name	Conditions	Value			Unit	Remarks
				Min	Typ	Max		
"H" level input voltage	V_{IH}	P00 to P07*5, P10 to P17*6, P22 to P27*11, P30 to P37*11, P40 to P45*11, P60*7 P72 to P77*11, P80 to P87*11, PA0 to PA5*11	—	$V_{CC} \times 0.7$	—	$V_{CC} + 0.3$	V	
"L" level input voltage	V_{IL}	P00 to P07*5, P10 to P17*6, P22 to P27*11, P30 to P37*11, P40 to P45*11, P60*7 P72 to P77*11, P80 to P87*11, PA0 to PA5*11	—	$V_{SS} - 0.3$	—	$V_{CC} \times 0.3$	V	
"H" level input voltage (hysteresis input)	V_{IHS}	P00 to P07*8, P10 to P17*9, P50 to P57, P60*10, P61 to P67, P70, P71, P72 to P77*12, P80 to P87*12, P90 to P92, PA0 to PA5*12 PA6, PA7, PK0 to PK3, \overline{INIT} , MD0, MD1	—	$V_{CC} \times 0.8$	—	$V_{CC} + 0.3$	V	
		P20, P21, P22 to P27*12, P30 to P37*12, P40 to P45*12, P46, P47, PG0 to PG7, PH0 to PH3	—	$V_{CC} \times 0.8$	—	$V_{SS} + 5.5$	V	5 V tolerant
"L" level input voltage (hysteresis input)	V_{ILS}	P00 to P07*8, P10 to P17*9, P20, P21, P22 to P27*12, P30 to P37*12, P40 to P45*12, P46, P47, P50 to P57, P60*10, P61 to P67, P70, P71, P72 to P77*12, P80 to P87*12, P90 to P92, PA0 to PA5*12, PA6, PA7, PG0 to PG7, PH0 to PH3, PK0 to PK3, \overline{INIT} , MD0, MD1	—	$V_{SS} - 0.3$	—	$V_{CC} \times 0.2$	V	

(Continued)

(Continued)

Parameter	Symbol	Pin name	Conditions	Value			Unit	Remarks
				Min	Typ	Max		
"H" level output voltage	V_{OH}	P00 to P07, P10 to P17, P20 to P27, P30 to P37, P40 to P47, P50 to P57, P60 to P67, P70 to P77, P80 to P87, P90 to P92,	$V_{CC} = 3.0\text{ V}$ $I_{OH} = -4\text{ mA}$	$V_{CC} - 0.5$	—	V_{CC}	V	
"L" level output voltage	V_{OL}	PA0 to PA7, PG0 to PG7, PH0 to PH3, PK0 to PK3	$V_{CC} = 3.0\text{ V}$ $I_{OL} = 4\text{ mA}$	V_{SS}	—	0.4	V	
Input leak current	I_{IL}	—	—	- 5	—	+ 5	μA	Digital pin
				- 10	—	+ 10	μA	Analog pin
Pull-up resistance value	R_{PU}	Pull-up pin	—	16.6	33	66	$\text{k}\Omega$	
Input capacitance	C_{IN}	Other than V_{CC} , V_{SS} , AV_{CC} , AV_{SS} , $AVRH$	—	—	10	15	pF	

*1 : When opened, all ports are fixed to output

*2 : $T_a = +25\text{ }^\circ\text{C}$ and $V_{CC} = 3.3\text{ V}$

*3 : $X0 = 8.3\text{ MHz}$, CPU clock = 33 MHz and $X0A =$ when stopped

*4 : $X0 = \text{STOP}$ and $X0A =$ at 32 kHz

*5 : When using as D00 to D07 pin

*6 : When using as D08 to D15 pin

*7 : When using as RDY input

*8 : When using other than D00 to D07 pin

*9 : When using other than D08 to D15 pin

*10 : When using other than RDY input

*11 : When using as Slave interface pin

*12 : When using other than Slave interface pin

MB91660 Series

• V-I characteristics

Conditions

Min : Process = Slow, $T_a = +85\text{ }^\circ\text{C}$, $V_{CC} = 2.7\text{ V}$

Typ : Process = Typical, $T_a = +25\text{ }^\circ\text{C}$, $V_{CC} = 3.3\text{ V}$

Max : Process = Fast, $T_a = -40\text{ }^\circ\text{C}$, $V_{CC} = 3.6\text{ V}$

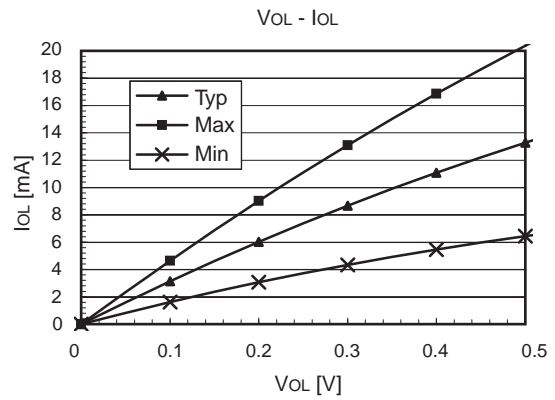
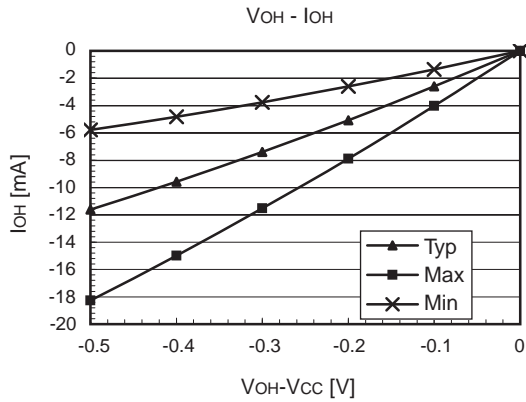

4. AC Characteristics

(1) Main Clock (MCLK) Input Standard

Not using USB : ($V_{CC} = AV_{CC} = 2.7 \text{ V to } 3.6 \text{ V}$, $V_{SS} = AV_{SS} = 0 \text{ V}$, $T_a = -40 \text{ }^\circ\text{C to } +85 \text{ }^\circ\text{C}$)

Using USB : ($V_{CC} = AV_{CC} = 3.0 \text{ V to } 3.6 \text{ V}$, $V_{SS} = AV_{SS} = 0 \text{ V}$, $T_a = -40 \text{ }^\circ\text{C to } +85 \text{ }^\circ\text{C}$)

Parameter	Symbol	Pin name	Conditions	Value		Unit	Remarks
				Min	Max		
Input frequency	F_{CH}	X0, X1	—	4	48	MHz	When crystal oscillator is connected
			—	4	48	MHz	When using external clock
Input clock cycle	t_{CYLH}		—	20.83	250	ns	When using external clock
Input clock pulse width	—		P_{WH}/t_{CYLH} P_{WL}/t_{CYLH}	45	55	%	When using external clock
Input clock rise time and fall time	t_{CF} t_{CR}	—	—	5	ns	When using external clock	
Internal operating clock frequency	F_{CS}	—	—	—	33	MHz	Source clock
	F_{CC}	—	—	—	33	MHz	CPU clock
	F_{CP}	—	—	—	33	MHz	Peripheral bus clock
	F_{CT}	—	—	—	33	MHz	External bus clock
Internal operating clock cycle time	t_{CYCS}	—	—	30	—	ns	Source clock
	t_{CYCC}	—	—	30	—	ns	CPU clock
	t_{CYCP}	—	—	30	—	ns	Peripheral bus clock
	t_{CYCT}	—	—	30	—	ns	External bus clock

MB91660 Series

- Operating guaranteed range (Not using USB)

- When the main clock is selected (DIVB=000)

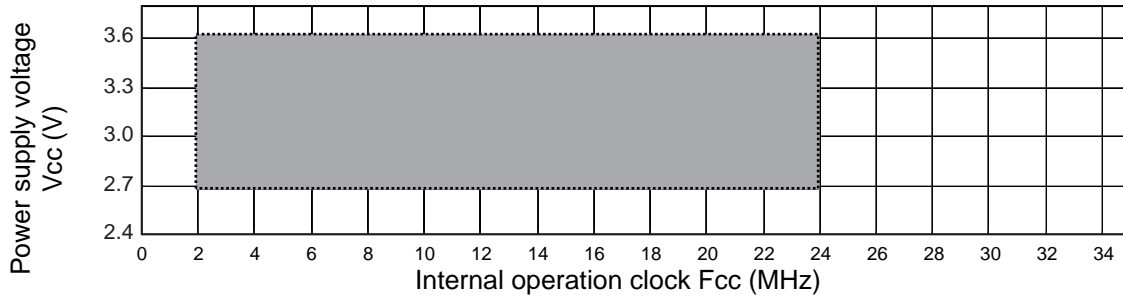

- When the PLL clock is selected (DIVB=000) Not using USB

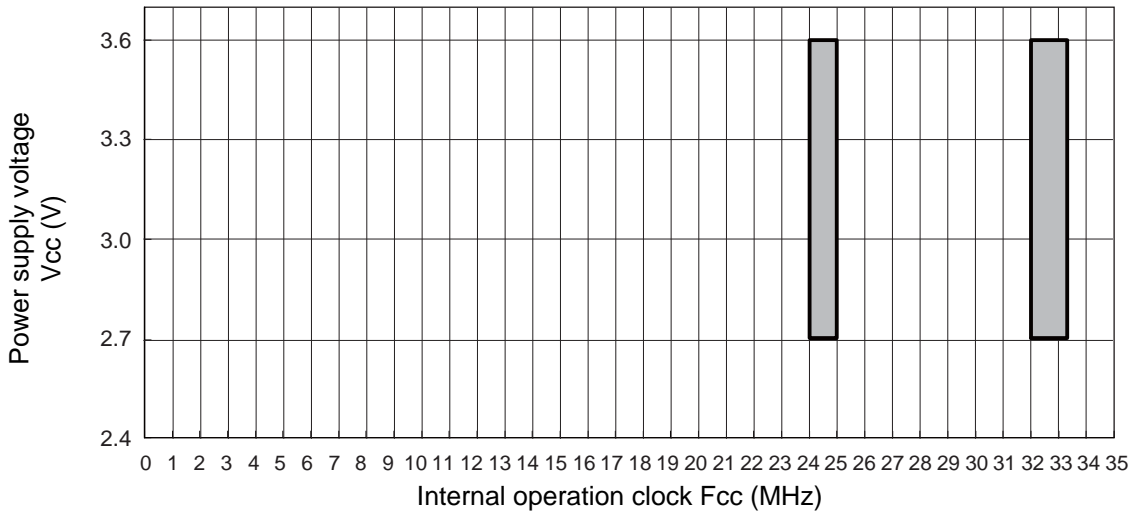

- When the sub clock is selected ($F_{CL} = 32.768$ kHz)

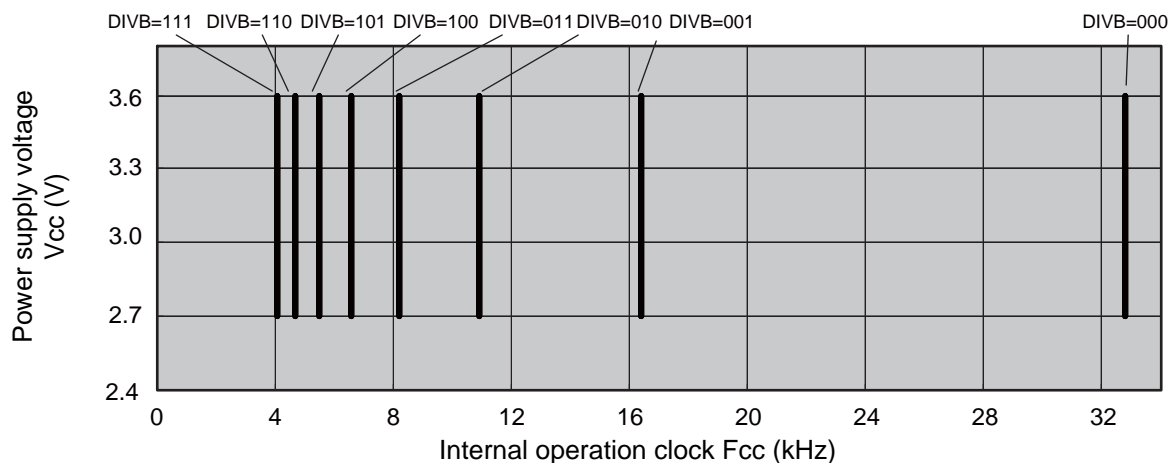

- Example of configuration

- When the main clock is selected (DIVB=000*1)

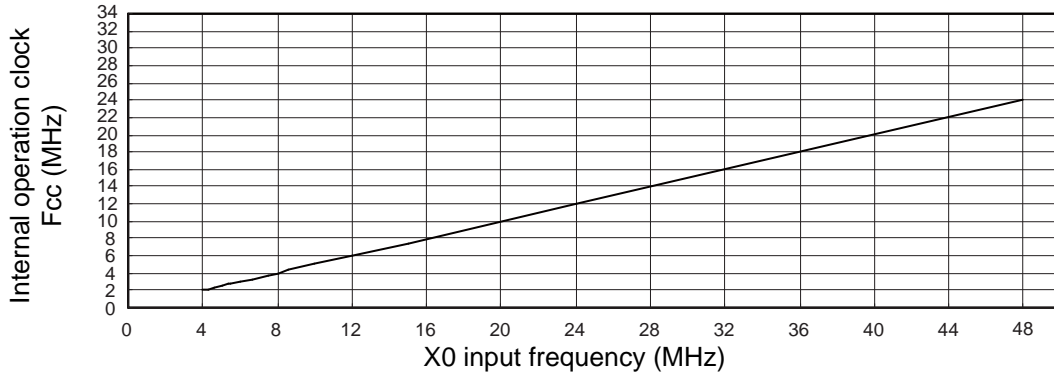

- When the PLL clock is selected (DIVB=000*1, PDS=0000*2)

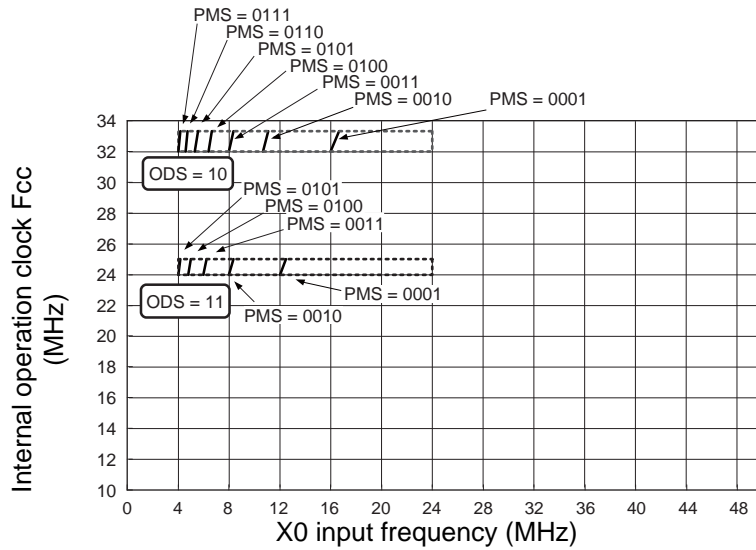

- When the PLL clock is selected (DIVB=000*1, PDS=0001*2)

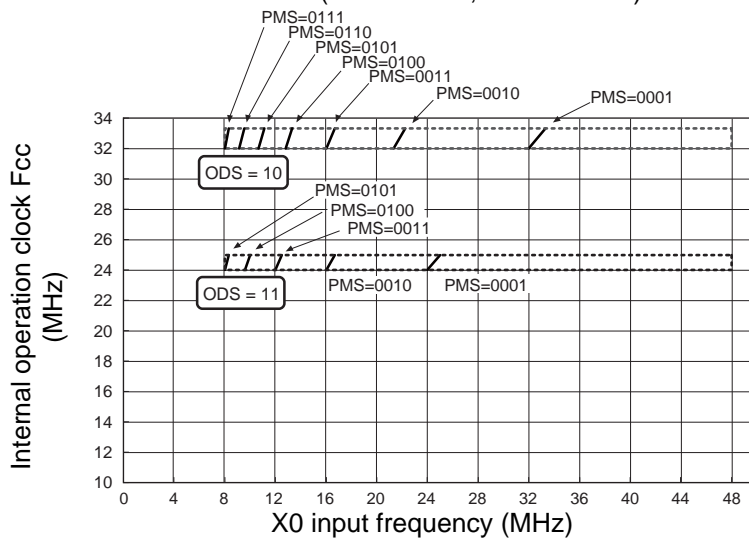

MB91660 Series

- Operating guaranteed range (at using USB)

- When the main clock is selected (DIVB = 000*¹)

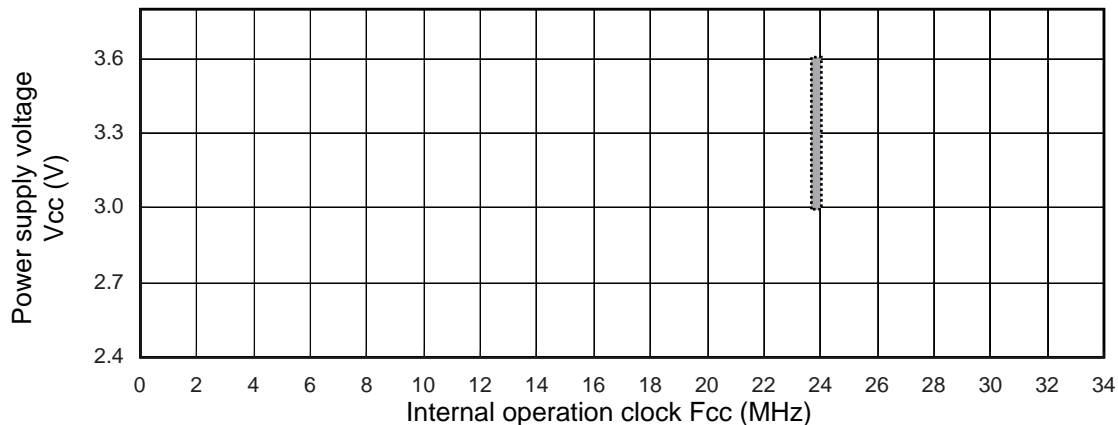

- When the PLL clock is selected (DIVB = 000*¹, ODS = 10*³, PMS = 0111*⁴, PDS=0000*², X0 = 4 MHz or DIVB = 000*¹, ODS = 10*³, PMS = 0001*⁴, PDS = 0010*², X0 = 48 MHz)

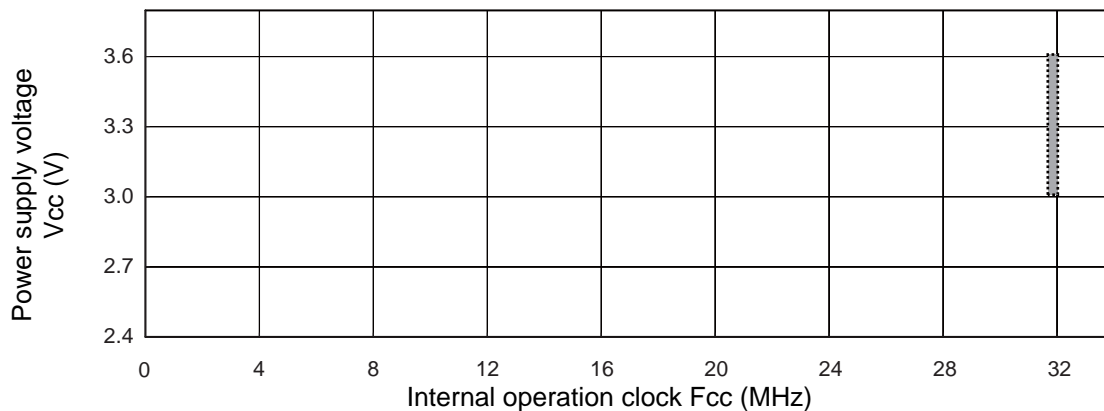

(Continued)

- Example of configuration

- When the main clock is selected (DIVB = 000*¹)

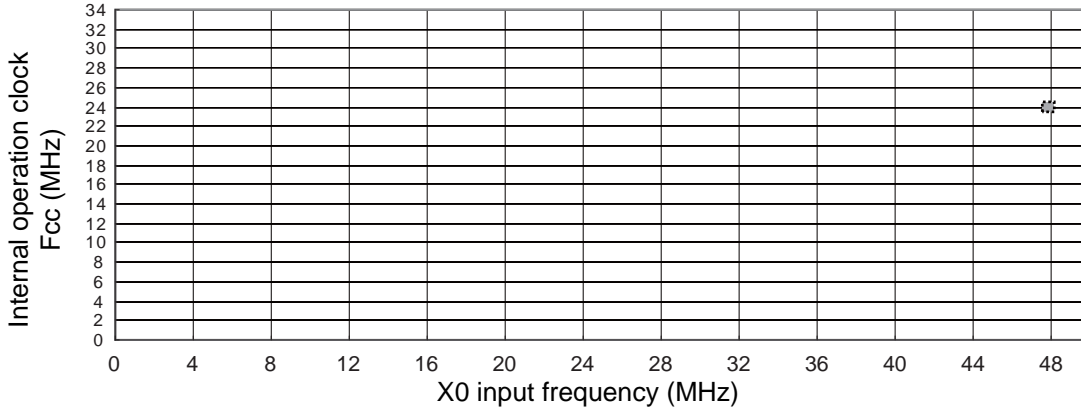

- When the PLL clock is selected (DIVB = 000*¹, ODS = 10*³, PMS = 0111*⁴, PDS = 0000*²)

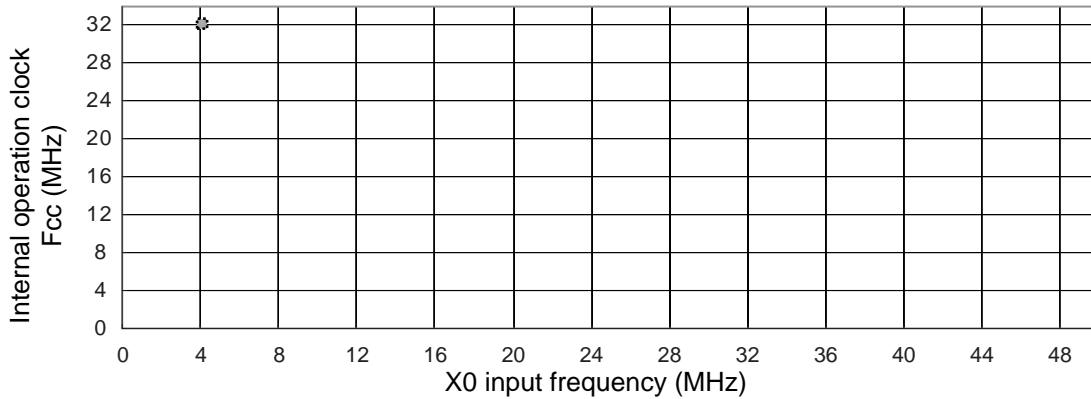

- When the PLL clock is selected (DIVB=000*¹, ODS=10*³, PMS=0001*⁴, PDS=0010*²)

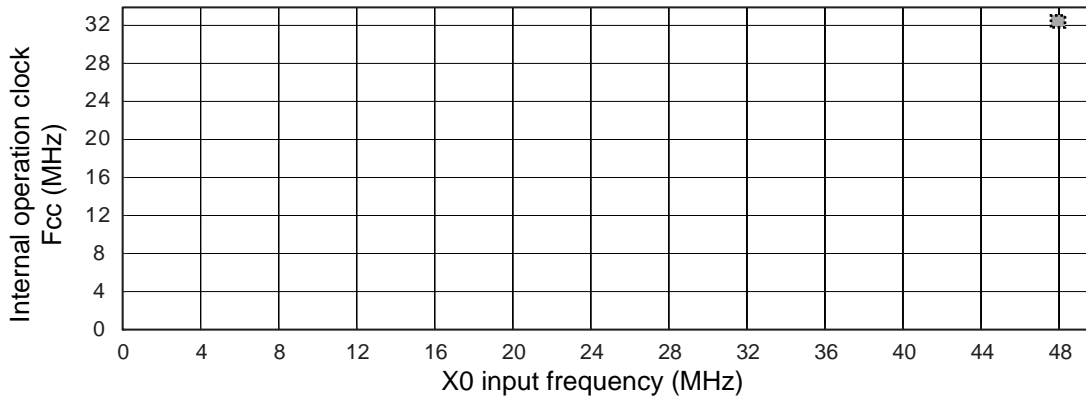

(Continued)

MB91660 Series

(Continued)

*1: The values other than DIVB = 000 are omitted.

*2: The values other than PDS = 0000, 0001, 0010 are omitted.

*3: The values other than ODS = 10 are omitted.

*4: The values other than PMS = 0001, 0111 are omitted.

Note: DIVB: Base clock division configuration bit
ODS : PLL macro oscillation clock division rate select bit
PDS : PLL input clock division select bit
PMS : PLL clock multiple rate select bit

(2) Sub Clock (SBCLK) Input Standard

Not using USB : ($V_{CC} = AV_{CC} = 2.7\text{ V}$ to 3.6 V , $V_{SS} = AV_{SS} = 0\text{ V}$, $T_a = -40\text{ }^\circ\text{C}$ to $+85\text{ }^\circ\text{C}$)

Using USB : ($V_{CC} = AV_{CC} = 3.0\text{ V}$ to 3.6 V , $V_{SS} = AV_{SS} = 0\text{ V}$, $T_a = -40\text{ }^\circ\text{C}$ to $+85\text{ }^\circ\text{C}$)

Parameter	Symbol	Pin name	Conditions	Value			Unit	Remarks
				Min	Typ	Max		
Input frequency	F _{CL}	X0A, X1A	—	—	32.768	—	kHz	When crystal oscillator is connected
			—	—	32.768	—		kHz
Input clock cycle	t _{CYLL}		—	—	30.518	—	μs	When using external clock
Input clock pulse width	—		P _{WH} / t _{CYLL} P _{WL} / t _{CYLL}	45	—	55	%	When using external clock
Input clock rise time and fall time	t _{CF} t _{CR}		—	—	—	200	ns	When using external clock

<When external clock input>

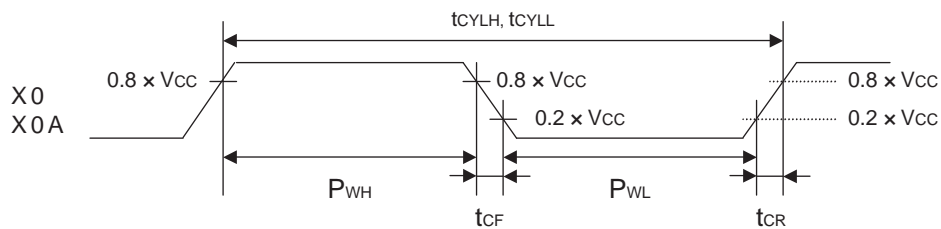

MB91660 Series

(3) Conditions of PLL

Not using USB : ($V_{CC} = AV_{CC} = 2.7 \text{ V}$ to 3.6 V , $V_{SS} = AV_{SS} = 0 \text{ V}$, $T_a = -40 \text{ }^\circ\text{C}$ to $+85 \text{ }^\circ\text{C}$)

Using USB : ($V_{CC} = AV_{CC} = 3.0 \text{ V}$ to 3.6 V , $V_{SS} = AV_{SS} = 0 \text{ V}$, $T_a = -40 \text{ }^\circ\text{C}$ to $+85 \text{ }^\circ\text{C}$)

Parameter	Symbol	Value			Unit	Remarks
		Min	Typ	Max		
PLL oscillation stabilization wait time (LOCK UP time)	t_{LOCK}	600	—	—	μs	Time from when the PLL starts operating until the oscillation stabilizes
PLL input clock frequency	f_{PLLI}	4	—	24	MHz	
PLL multiple rate	—	4	—	24	multiplied by	ODS \times PMS
PLL macro oscillation clock frequency	f_{PLLO}	96	—	100	MHz	

(4) Regulator Voltage Stabilization Wait Time

Not using USB : ($V_{CC} = AV_{CC} = 2.7 \text{ V}$ to 3.6 V , $V_{SS} = AV_{SS} = 0 \text{ V}$, $T_a = -40 \text{ }^\circ\text{C}$ to $+85 \text{ }^\circ\text{C}$)

Using USB : ($V_{CC} = AV_{CC} = 3.0 \text{ V}$ to 3.6 V , $V_{SS} = AV_{SS} = 0 \text{ V}$, $T_a = -40 \text{ }^\circ\text{C}$ to $+85 \text{ }^\circ\text{C}$)

Parameter	Symbol	Value		Unit	Remarks
		Min	Max		
Regulator voltage stabilization wait time	t_{REG}	50	—	μs	Time taken for the regulator voltage to stabilize

- Notes:
- This is the time from when the external power supply stabilizes (after reaching 2.7 V) when USB is not used.
 - This is the time from when the external power supply stabilizes (after reaching 3.0 V) when USB is used.

(5) Reset Input Standards

Not using USB : ($V_{CC} = AV_{CC} = 2.7\text{ V}$ to 3.6 V , $V_{SS} = AV_{SS} = 0\text{ V}$, $T_a = -40\text{ }^\circ\text{C}$ to $+85\text{ }^\circ\text{C}$)

Using USB : ($V_{CC} = AV_{CC} = 3.0\text{ V}$ to 3.6 V , $V_{SS} = AV_{SS} = 0\text{ V}$, $T_a = -40\text{ }^\circ\text{C}$ to $+85\text{ }^\circ\text{C}$)

Parameter	Symbol	Pin name	Condi- tions	Value		Unit	Remarks
				Min	Max		
Reset input time (At power-on, main oscillation stop mode)	t_{INITX}	\overline{INIT}	—	Oscillation time of oscillator + $10 t_{CYLH}$	—	ns	*
Reset input time (At other times)				$10 t_{CYLH}$	—	ns	
Reset input rise time and fall time	t_{INITXF} t_{INITXR}			—	—	10	ms

* : After the supply voltage has stabilized, it takes a further $50\text{ }\mu\text{s}$ until the internal supply stabilizes. Hold the input to the \overline{INIT} pin during that period.

- At power-on
- When in stop mode
- When in sub mode and sub watch mode when the main oscillation is stopped.

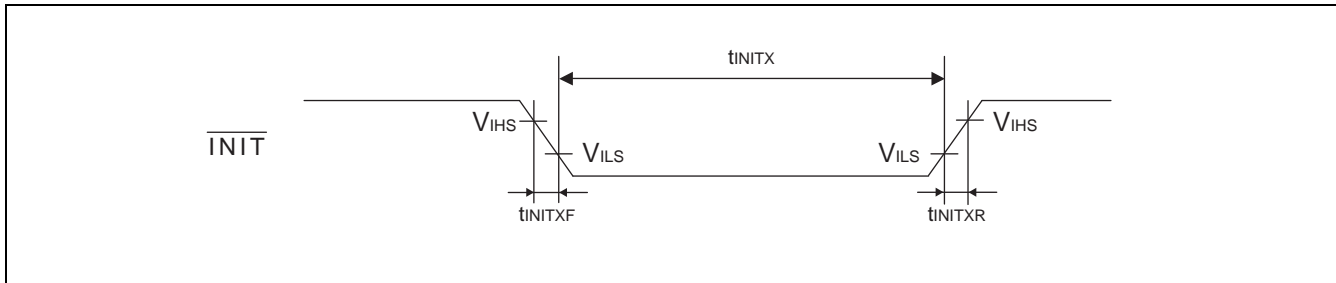

MB91660 Series

(6) Clock Output Timing

- $t_{CHCL} : t_{CLCH} = 1 : 1$ (divided by 1, 2, 4, 6, 8)

Not using USB : ($V_{CC} = AV_{CC} = 2.7\text{ V to }3.6\text{ V}$, $V_{SS} = AV_{SS} = 0\text{ V}$, $T_a = -40\text{ }^\circ\text{C to }+85\text{ }^\circ\text{C}$)

Using USB : ($V_{CC} = AV_{CC} = 3.0\text{ V to }3.6\text{ V}$, $V_{SS} = AV_{SS} = 0\text{ V}$, $T_a = -40\text{ }^\circ\text{C to }+85\text{ }^\circ\text{C}$)

Parameter	Symbol	Pin name	Conditions	Value		Unit
				Min	Max	
Cycle time	t_{CYC}	SYSCLK	$F_{CT} = F_{CC}$, $F_{CT} = F_{CC}/2$	t_{CYCT}	—	ns
SYSCLK \uparrow →SYSCLK \downarrow	t_{CHCL}			$t_{CYC} / 2 - 5$	$t_{CYC} / 2 + 5$	ns
SYSCLK \downarrow →SYSCLK \uparrow	t_{CLCH}			$t_{CYC} / 2 - 5$	$t_{CYC} / 2 + 5$	ns

Notes: • t_{CYC} is a frequency of 1 clock cycle indicating gear ratio.

- When DIVT = 000, be sure to set as DIVB = 000.

- $t_{CHCL} : t_{CLCH} = 1 : 2$ (divided by 3)

Not using USB : ($V_{CC} = AV_{CC} = 2.7\text{ V to }3.6\text{ V}$, $V_{SS} = AV_{SS} = 0\text{ V}$, $T_a = -40\text{ }^\circ\text{C to }+85\text{ }^\circ\text{C}$)

Using USB : ($V_{CC} = AV_{CC} = 3.0\text{ V to }3.6\text{ V}$, $V_{SS} = AV_{SS} = 0\text{ V}$, $T_a = -40\text{ }^\circ\text{C to }+85\text{ }^\circ\text{C}$)

Parameter	Symbol	Pin name	Conditions	Value		Unit
				Min	Max	
Cycle time	t_{CYC}	SYSCLK	$F_{CT} = F_{CC}$, $F_{CT} = F_{CC}/2$	t_{CYCT}	—	ns
SYSCLK \uparrow →SYSCLK \downarrow	t_{CHCL}			$1 / 3 t_{CYC} - 5$	$1 / 3 t_{CYC} + 5$	ns
SYSCLK \downarrow →SYSCLK \uparrow	t_{CLCH}			$2 / 3 t_{CYC} - 5$	$2 / 3 t_{CYC} + 5$	ns

Note : t_{CYC} is a frequency of 1 clock cycle indicating gear ratio.

- $t_{CHCL} : t_{CLCH} = 2 : 3$ (divided by 5)

Not using USB : ($V_{CC} = AV_{CC} = 2.7\text{ V to }3.6\text{ V}$, $V_{SS} = AV_{SS} = 0\text{ V}$, $T_a = -40\text{ }^\circ\text{C to }+85\text{ }^\circ\text{C}$)

Using USB : ($V_{CC} = AV_{CC} = 3.0\text{ V to }3.6\text{ V}$, $V_{SS} = AV_{SS} = 0\text{ V}$, $T_a = -40\text{ }^\circ\text{C to }+85\text{ }^\circ\text{C}$)

Parameter	Symbol	Pin name	Conditions	Value		Unit
				Min	Max	
Cycle time	t_{CYC}	SYSCLK	$F_{CT} = F_{CC}$, $F_{CT} = F_{CC}/2$	t_{CYCT}	—	ns
SYSCLK \uparrow →SYSCLK \downarrow	t_{CHCL}			$2 / 5 t_{CYC} - 5$	$2 / 5 t_{CYC} + 5$	ns
SYSCLK \downarrow →SYSCLK \uparrow	t_{CLCH}			$3 / 5 t_{CYC} - 5$	$3 / 5 t_{CYC} + 5$	ns

Note : t_{CYC} is a frequency of 1 clock cycle indicating gear ratio.

- $t_{CHCL} : t_{CLCH} = 3 : 4$ (divided by 7)

Not using USB : ($V_{CC} = AV_{CC} = 2.7\text{ V to }3.6\text{ V}$, $V_{SS} = AV_{SS} = 0\text{ V}$, $T_a = -40\text{ }^\circ\text{C to }+85\text{ }^\circ\text{C}$)

Using USB : ($V_{CC} = AV_{CC} = 3.0\text{ V to }3.6\text{ V}$, $V_{SS} = AV_{SS} = 0\text{ V}$, $T_a = -40\text{ }^\circ\text{C to }+85\text{ }^\circ\text{C}$)

Parameter	Symbol	Pin name	Conditions	Value		Unit
				Min	Max	
Cycle time	t_{CYC}	SYSCLK	$F_{CT} = F_{CC}$, $F_{CT} = F_{CC}/2$	t_{CYCT}	—	ns
SYSCLK \uparrow →SYSCLK \downarrow	t_{CHCL}			$3 / 7 t_{CYC} - 5$	$3 / 7 t_{CYC} + 5$	ns
SYSCLK \downarrow →SYSCLK \uparrow	t_{CLCH}			$4 / 7 t_{CYC} - 5$	$4 / 7 t_{CYC} + 5$	ns

Note: t_{CYC} is a frequency of 1 clock cycle indicating gear ratio.

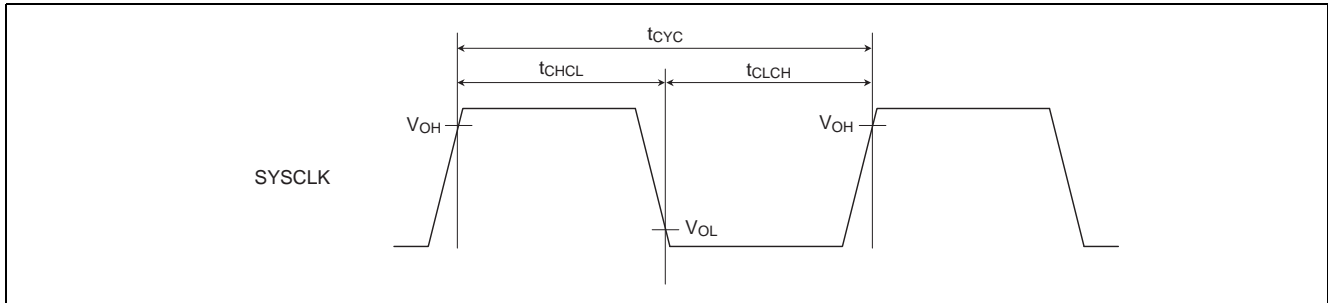

MB91660 Series

(7) External Bus Access Read/Write Operation

Not using USB : ($V_{CC} = AV_{CC} = 2.7 \text{ V}$ to 3.6 V , $V_{SS} = AV_{SS} = 0 \text{ V}$, $T_a = -40 \text{ }^\circ\text{C}$ to $+85 \text{ }^\circ\text{C}$)

Using USB : ($V_{CC} = AV_{CC} = 3.0 \text{ V}$ to 3.6 V , $V_{SS} = AV_{SS} = 0 \text{ V}$, $T_a = -40 \text{ }^\circ\text{C}$ to $+85 \text{ }^\circ\text{C}$)

Parameter	Symbol	Pin name	Condi- tions	Value		Unit	Remarks
				Min	Max		
$\overline{\text{AS}}$ delay time	t_{CHASL}	SYSCLK $\overline{\text{AS}}$	—	0.6	10	ns	
	t_{CHASH}						
$\overline{\text{CS0}}$ to $\overline{\text{CS3}}$ delay time	t_{CHCSL}	SYSCLK $\overline{\text{CS0}}$ to $\overline{\text{CS3}}$		0.6	10	ns	
	t_{CHCSH}						
Address delay time	t_{CHAV}	SYSCLK A23 to A00		0.6	10	ns	
	t_{CHAX}						
$\overline{\text{RD}}$ delay time	t_{CHRL}	SYSCLK $\overline{\text{RD}}$		0.6	10	ns	
	t_{CHRH}						
$\overline{\text{RD}}$ minimum pulse width	t_{RLRH}	$\overline{\text{RD}}$		$t_{\text{CYC}} - 10$	—	ns	*
Data setup $\rightarrow \overline{\text{RD}}\uparrow$ time	t_{DSRH}	$\overline{\text{RD}}$		18	—	ns	
$\overline{\text{RD}}\uparrow \rightarrow$ data hold time	t_{RHDL}	D15 to D00		0	—	ns	
$\overline{\text{WR0}}$, $\overline{\text{WR1}}$ delay time	t_{CHWL}	SYSCLK $\overline{\text{WR0}}$, $\overline{\text{WR1}}$		0.6	10	ns	
	t_{CHWH}						
$\overline{\text{WR0}}$, $\overline{\text{WR1}}$ minimum pulse width	t_{WLWH}	$\overline{\text{WR0}}$, $\overline{\text{WR1}}$	$t_{\text{CYC}} - 10$	—	ns	*	
SYSCLK $\uparrow \rightarrow$ Data output time	t_{CHDV}	SYSCLK	0.6	15	ns		
SYSCLK $\uparrow \rightarrow$ Data hold time	t_{CHDX}	D15 to D00	0.6	15	ns		

* : When the bus timing is delayed by an automatic wait insertion or RDY input, add the time ($t_{\text{CYC}} \times$ the number of delay cycles added) to this rating.

Note: When the external load capacitance $C = 50 \text{ pF}$.

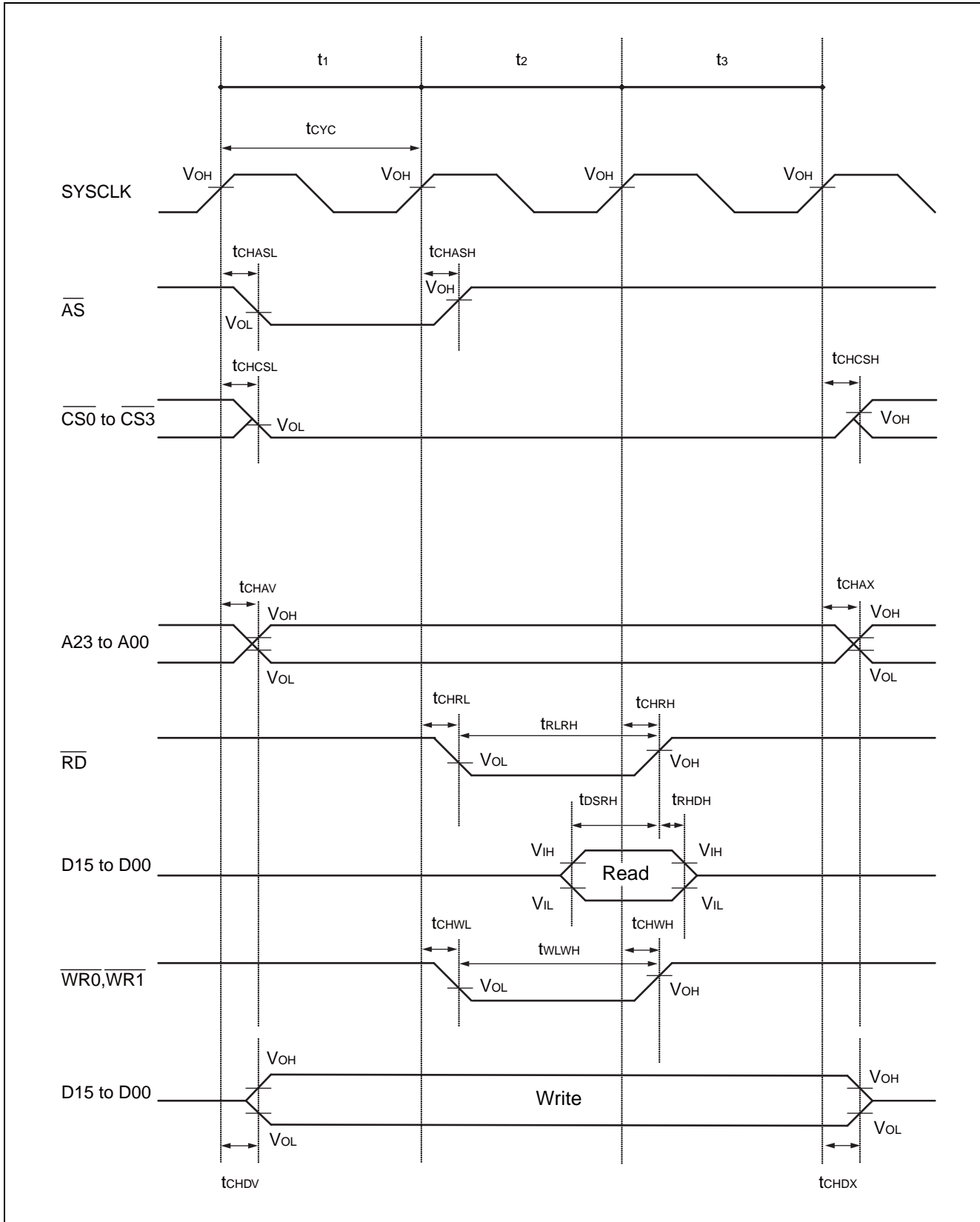

MB91660 Series

(8) Multiplexed Bus Access Read/Write Operation

Not using USB : ($V_{CC} = AV_{CC} = 2.7\text{ V to }3.6\text{ V}$, $V_{SS} = AV_{SS} = 0\text{ V}$, $T_a = -40\text{ }^\circ\text{C to }+85\text{ }^\circ\text{C}$)

Using USB : ($V_{CC} = AV_{CC} = 3.0\text{ V to }3.6\text{ V}$, $V_{SS} = AV_{SS} = 0\text{ V}$, $T_a = -40\text{ }^\circ\text{C to }+85\text{ }^\circ\text{C}$)

Parameter	Symbol	Pin name	Condi- tions	Value		Unit
				Min	Max	
SYSClk \uparrow \rightarrow D15 to D00 address delay time	t_{CHMAV} t_{CHMAX}	SYSClk D15 to D00 (address)	—	0.6	15	ns
SYSClk \uparrow \rightarrow D15 to D00 data delay time	t_{CHMDV}			0.6	15	ns

Notes : • The ratings not listed here are the same as the normal bus interface.

• When the external load capacitance $C = 50\text{ pF}$.

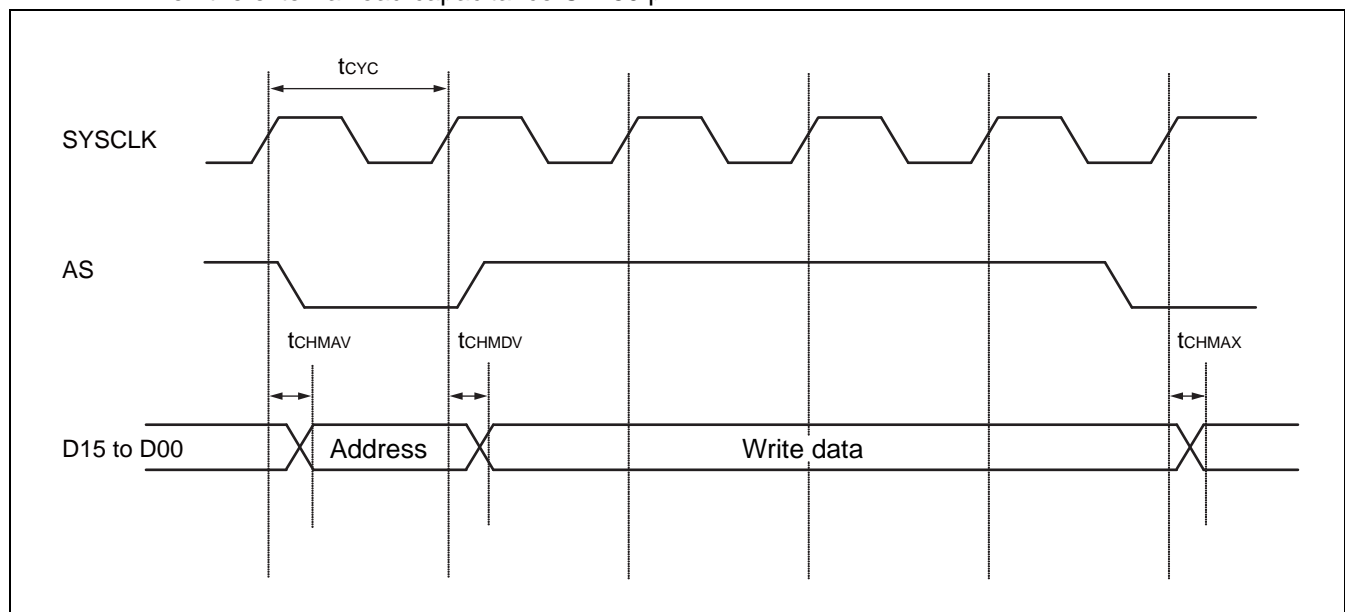

(9) Ready Input Timing

Not using USB : ($V_{CC} = AV_{CC} = 2.7\text{ V to }3.6\text{ V}$, $V_{SS} = AV_{SS} = 0\text{ V}$, $T_a = -40\text{ }^{\circ}\text{C to }+85\text{ }^{\circ}\text{C}$)

Using USB : ($V_{CC} = AV_{CC} = 3.0\text{ V to }3.6\text{ V}$, $V_{SS} = AV_{SS} = 0\text{ V}$, $T_a = -40\text{ }^{\circ}\text{C to }+85\text{ }^{\circ}\text{C}$)

Parameter	Symbol	Pin name	Condi- tions	Value		Unit
				Min	Max	
RDY setup time \rightarrow SYSCLK \uparrow	t_{RDYS}	SYSCLK RDY	—	18	—	ns
SYSCLK \uparrow \rightarrow RDY hold time	t_{RDYH}	SYSCLK RDY	—	0	—	ns

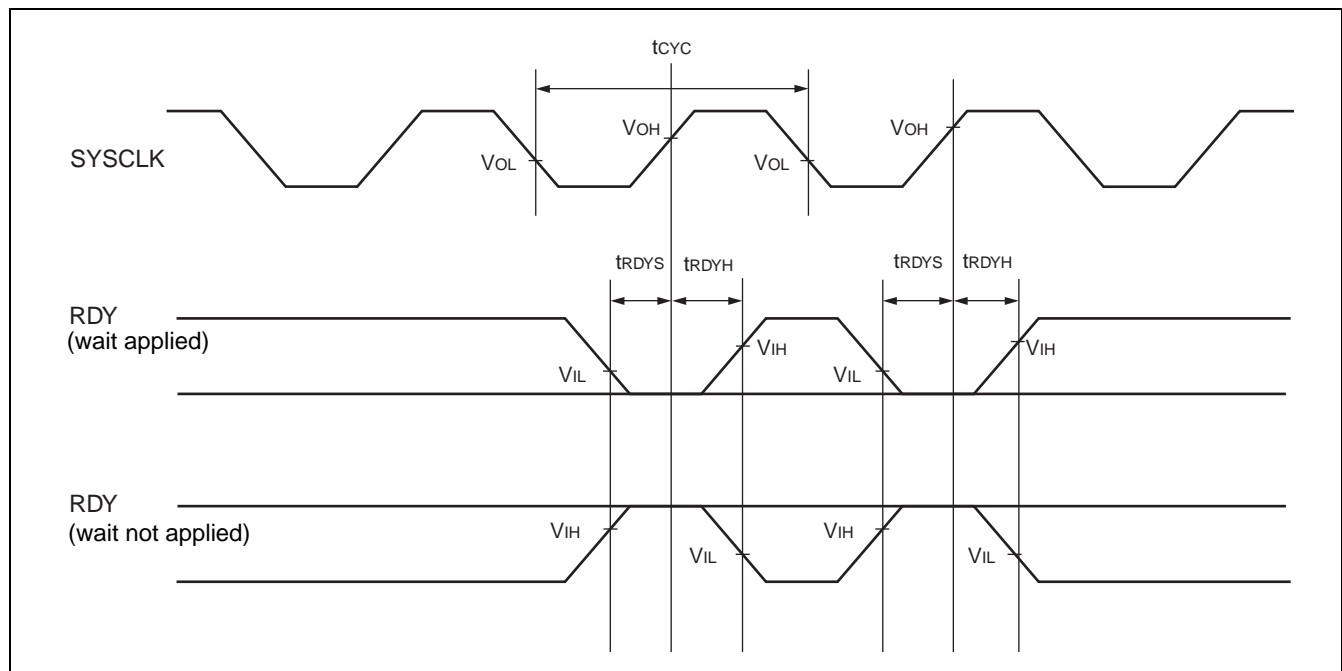

MB91660 Series

(10) DMA Controller Timing

Not using USB : ($V_{CC} = AV_{CC} = 2.7\text{ V to }3.6\text{ V}$, $V_{SS} = AV_{SS} = 0\text{ V}$, $T_a = -40\text{ }^\circ\text{C to }+85\text{ }^\circ\text{C}$)

Using USB : ($V_{CC} = AV_{CC} = 3.0\text{ V to }3.6\text{ V}$, $V_{SS} = AV_{SS} = 0\text{ V}$, $T_a = -40\text{ }^\circ\text{C to }+85\text{ }^\circ\text{C}$)

Parameter	Symbol	Pin name	Condi- tions	Value		Unit
				Min	Max	
DREQ input pulse width	t_{DRWH}	DREQn	—	$2 t_{CYCT}$	—	ns
DACK delay time	t_{CHDAL}	SYSCLK DACKn		0.6	10	ns
	t_{CHDAH}					
DEOP delay time	t_{CHDEL}	SYSCLK DEOPn		0.6	10	ns
	t_{CHDEH}					
DREQ setup time	T_{CHDRS}	SYSCLK DREQn		18	—	ns
DREQ hold time	T_{CHDRH}	SYSCLK DREQn	0	—	ns	

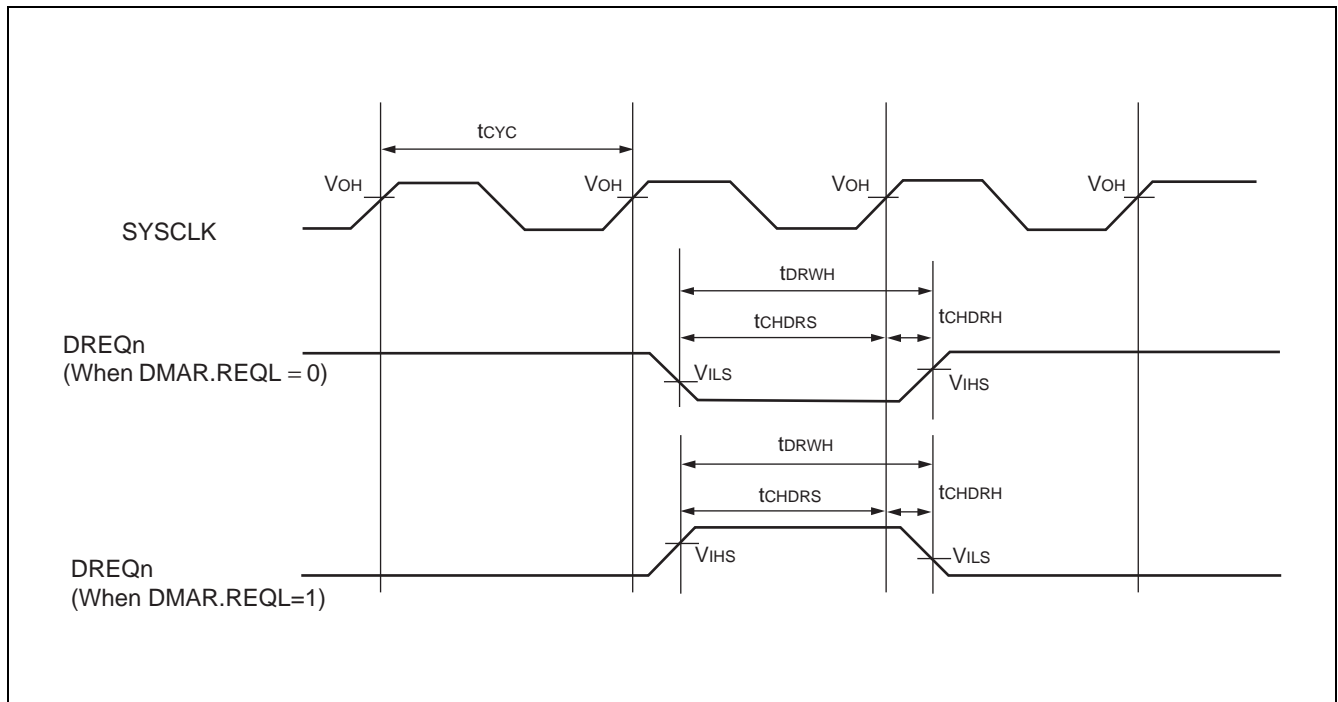

Note: When the external load capacitance $C = 50\text{ pF}$.

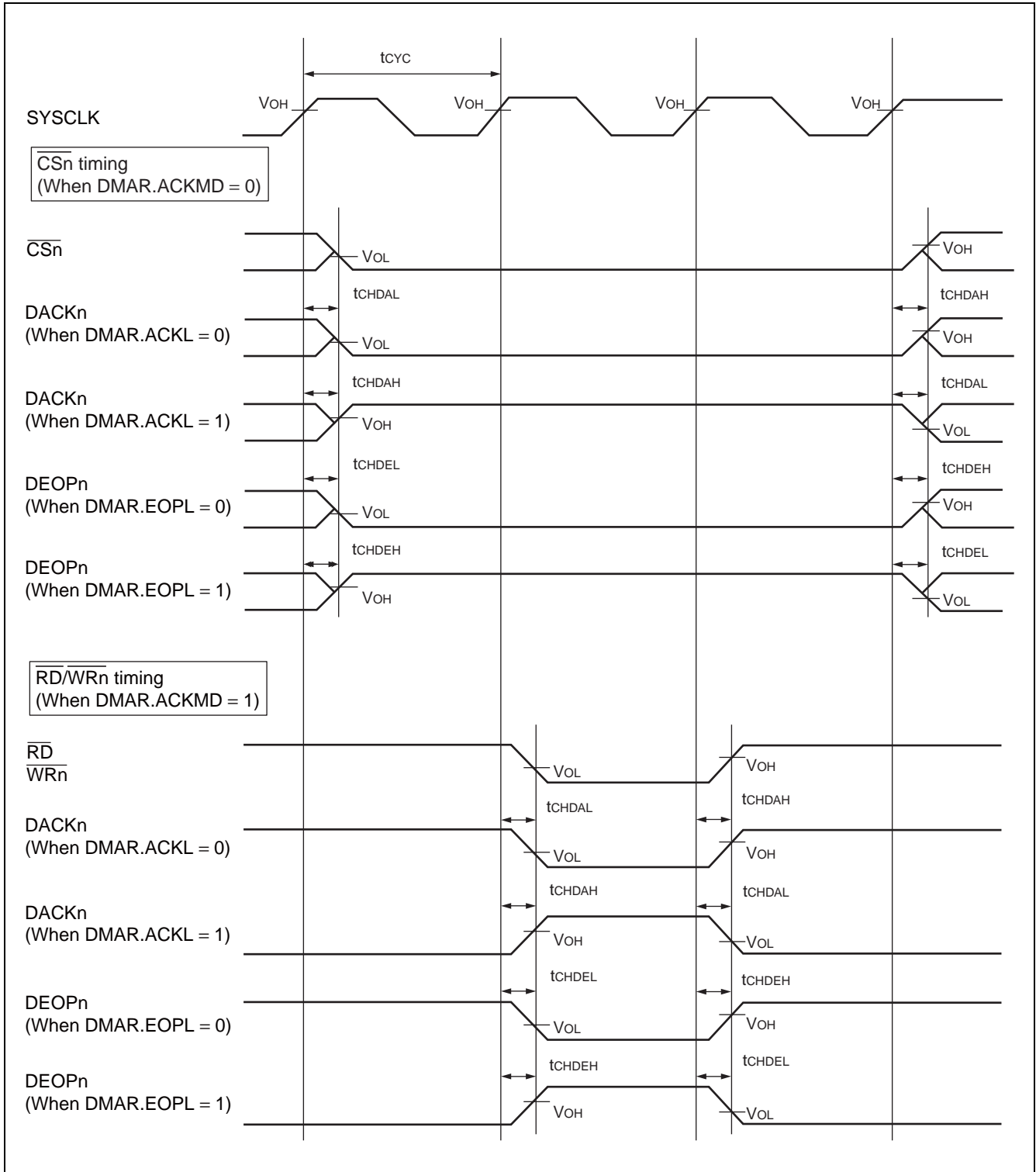

MB91660 Series

(11) Base Timer Input Timing

- Timer input timing

Not using USB : ($V_{CC} = AV_{CC} = 2.7\text{ V to }3.6\text{ V}$, $V_{SS} = AV_{SS} = 0\text{ V}$, $T_a = -40\text{ }^\circ\text{C to }+85\text{ }^\circ\text{C}$)

Using USB : ($V_{CC} = AV_{CC} = 3.0\text{ V to }3.6\text{ V}$, $V_{SS} = AV_{SS} = 0\text{ V}$, $T_a = -40\text{ }^\circ\text{C to }+85\text{ }^\circ\text{C}$)

Parameter	Symbol	Pin name	Condi- tions	Value		Unit
				Min	Max	
Input pulse width	t_{TIWH} t_{TIWL}	TIOAn/TIOBn (When used as ECK, TIN)	—	$2 t_{CYCP}$	—	ns

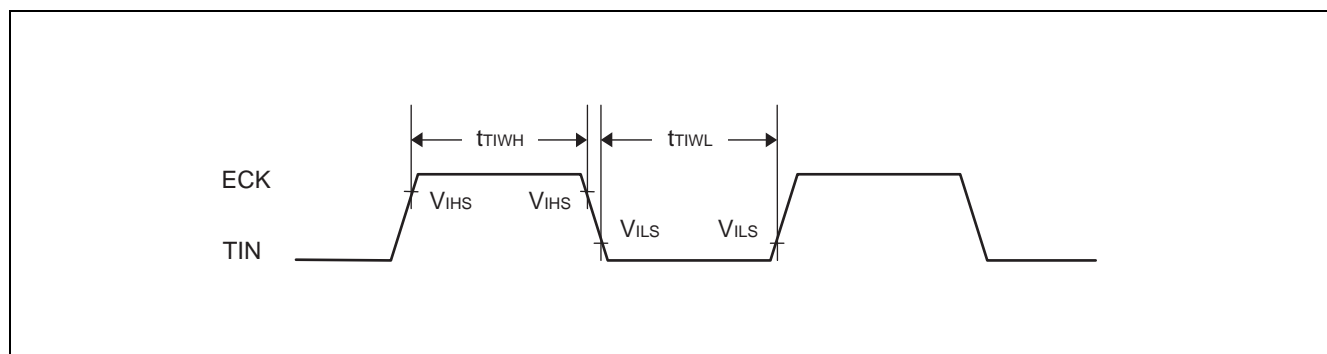

- Trigger Input Timing

Not using USB : ($V_{CC} = AV_{CC} = 2.7\text{ V to }3.6\text{ V}$, $V_{SS} = AV_{SS} = 0\text{ V}$, $T_a = -40\text{ }^\circ\text{C to }+85\text{ }^\circ\text{C}$)

Using USB : ($V_{CC} = AV_{CC} = 3.0\text{ V to }3.6\text{ V}$, $V_{SS} = AV_{SS} = 0\text{ V}$, $T_a = -40\text{ }^\circ\text{C to }+85\text{ }^\circ\text{C}$)

Parameter	Symbol	Pin name	Condi- tions	Value		Unit
				Min	Max	
Input pulse width	t_{TRGH} t_{TRGL}	TIOAn/TIOBn (When used as TGIN)	—	$2 t_{CYCP}$	—	ns

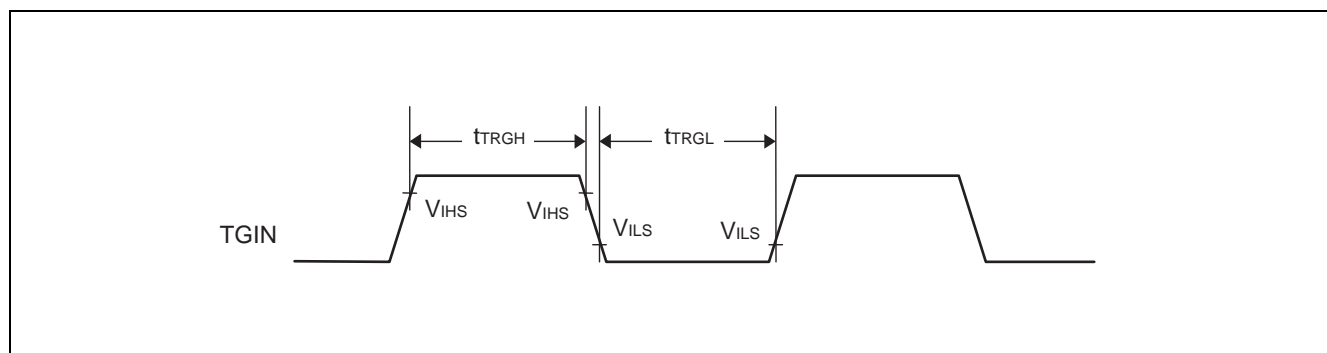

(12) Synchronous serial (CSIO) timing

Not using USB : ($V_{CC} = AV_{CC} = 2.7 \text{ V to } 3.6 \text{ V}$, $V_{SS} = AV_{SS} = 0 \text{ V}$, $T_a = -40 \text{ }^\circ\text{C to } +85 \text{ }^\circ\text{C}$)

Using USB : ($V_{CC} = AV_{CC} = 3.0 \text{ V to } 3.6 \text{ V}$, $V_{SS} = AV_{SS} = 0 \text{ V}$, $T_a = -40 \text{ }^\circ\text{C to } +85 \text{ }^\circ\text{C}$)

- Synchronous serial (SPI = 0, SCINV = 0)

Parameter	Symbol	Pin name	Conditions	Value		Unit
				Min	Max	
Serial clock cycle time	t_{SCYC}	SCKn	Internal shift clock operation	$4t_{CYCP}$	—	ns
SCK ↓ → SOUT delay time	t_{SLOVI}	SCKn SOUTn		- 30	+ 30	ns
SIN → SCK ↑ setup time	t_{IVSHI}	SCKn SINn		57	—	ns
SCK ↑ → SIN hold time	t_{SHIXI}	SCKn SINn		0	—	ns
Serial clock "L" pulse width	t_{SLSH}	SCKn	External shift clock operation	$2t_{CYCP} - 10$	—	ns
Serial clock "H" pulse width	t_{SHSL}	SCKn		$t_{CYCP} + 10$	—	ns
SCK ↓ → SOUT delay time	t_{SLOVE}	SCKn SOUTn		—	48	ns
SIN → SCK ↑ setup time	t_{IVSHE}	SCKn SINn		25	—	ns
SCK ↑ → SIN hold time	t_{SHIXE}	SCKn SINn		20	—	ns
SCK fall time	t_f	SCKn		—	5	ns
SCK rise time	t_r	SCKn		—	5	ns

Notes: • The above standards apply to CLK synchronous mode.

- t_{CYCP} indicates the peripheral clock cycle time.
- When the external load capacitance $C = 50 \text{ pF}$.

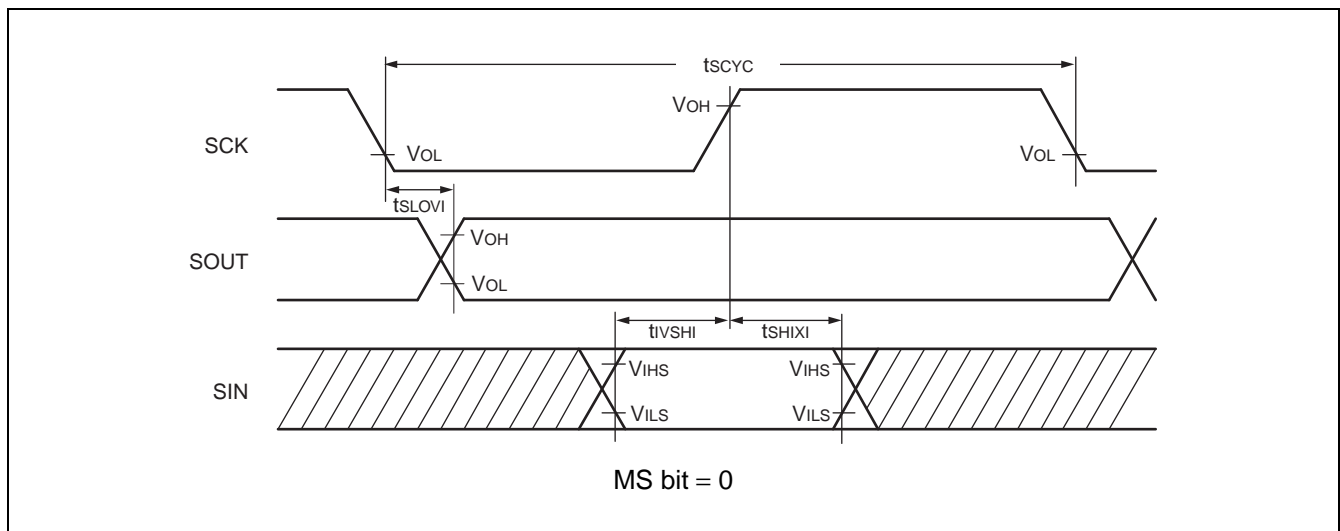

MB91660 Series

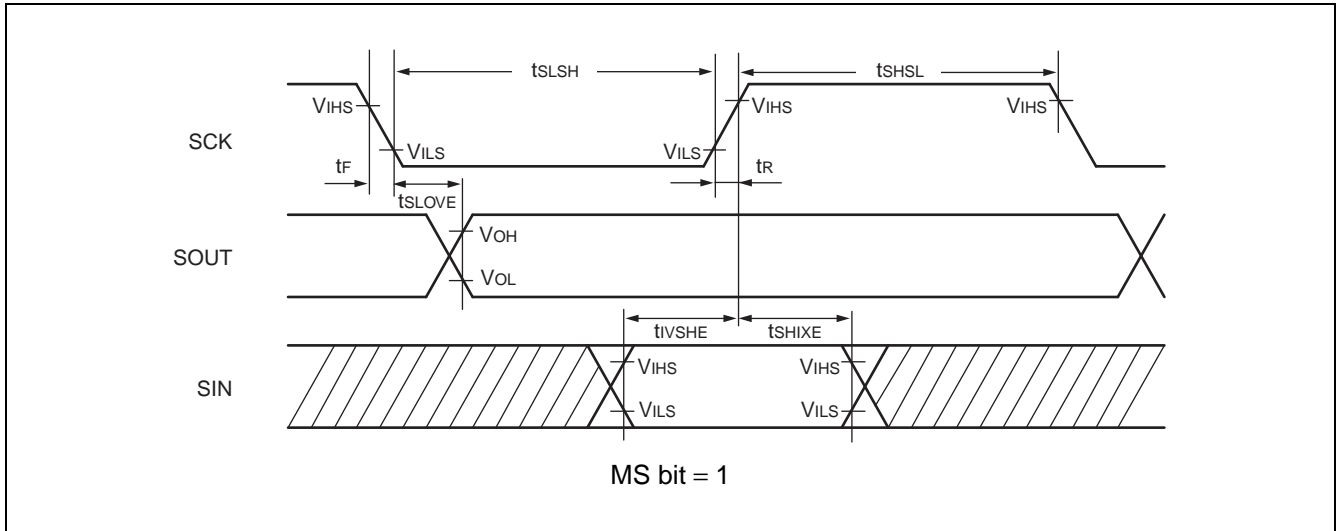

• Synchronous serial (SPI = 0, SCINV = 1)

Parameter	Symbol	Pin name	Conditions	Value		Unit
				Min	Max	
Serial clock cycle time	t_{SCYC}	SCKn	Internal shift clock operation	$4t_{CYCP}$	—	ns
SCK \uparrow \rightarrow SOUT delay time	t_{SHOVI}	SCKn SOUTn		- 30	+ 30	ns
SIN \rightarrow SCK \downarrow setup time	t_{IVSLI}	SCKn SINn		57	—	ns
SCK \downarrow \rightarrow SIN hold time	t_{SLIXI}	SCKn SINn		0	—	ns
Serial clock "L" pulse width	t_{SLSH}	SCKn	External shift clock operation	$2t_{CYCP} - 10$	—	ns
Serial clock "H" pulse width	t_{SHSL}	SCKn		$t_{CYCP} + 10$	—	ns
SCK \uparrow \rightarrow SOUT delay time	t_{SHOVE}	SCKn SOUTn		—	48	ns
SIN \rightarrow SCK \downarrow setup time	t_{IVSLE}	SCKn SINn		25	—	ns
SCK \downarrow \rightarrow SIN hold time	t_{SLIXE}	SCKn SINn		20	—	ns
SCK fall time	t_F	SCKn		—	5	ns
SCK rise time	t_R	SCKn		—	5	ns

Notes: • The above standards apply to CLK synchronous mode.

- t_{CYCP} indicates the peripheral clock cycle time.
- When the external load capacitance $C = 50$ pF.

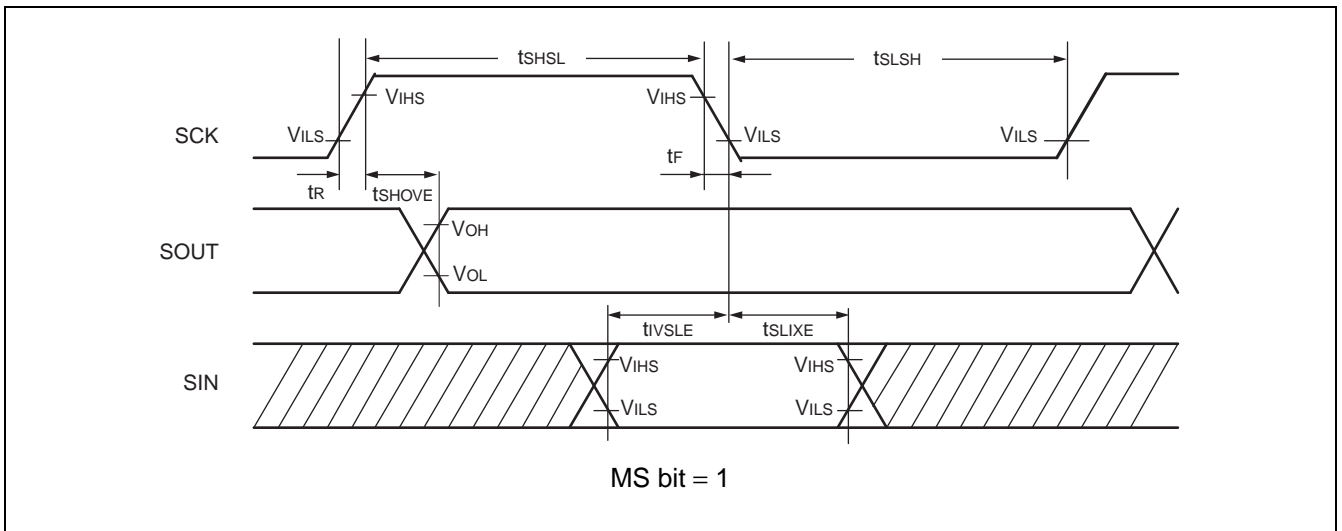
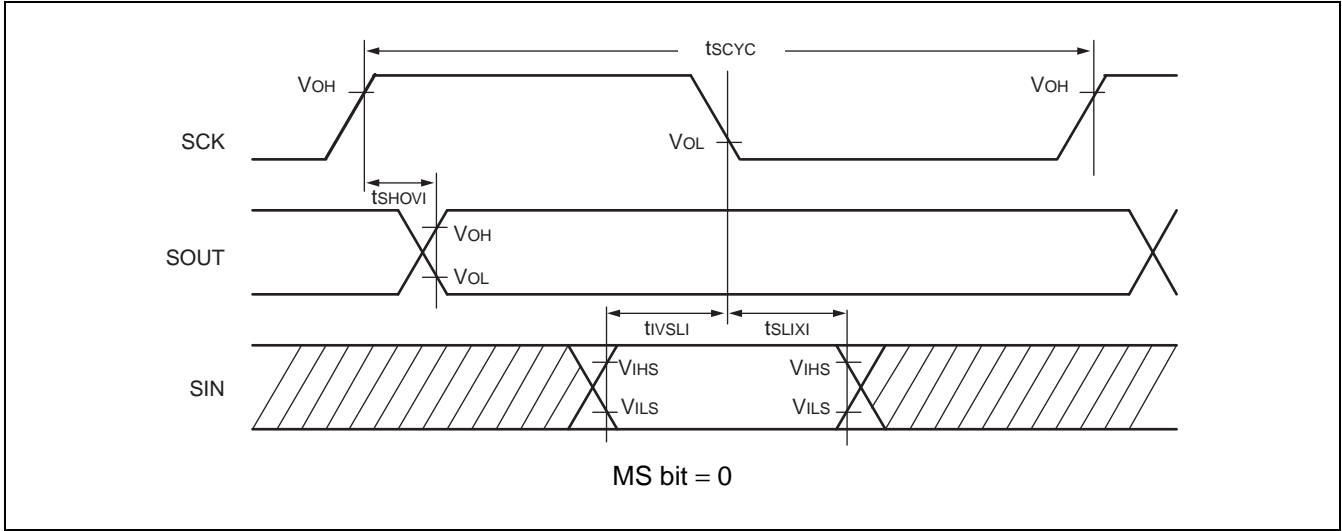

MB91660 Series

- Synchronous serial (SPI = 1, SCINV = 0)

Parameter	Symbol	Pin name	Conditions	Value		Unit
				Min	Max	
Serial clock cycle time	t_{SCYC}	SCKn	Internal shift clock operation	$4t_{CYCP}$	—	ns
SCK \uparrow \rightarrow SOUT delay time	t_{SHOVI}	SCKn SOUTn		- 30	+ 30	ns
SIN \rightarrow SCK \downarrow setup time	t_{IVSLI}	SCKn SINn		57	—	ns
SCK \downarrow \rightarrow SIN hold time	t_{SLIXI}	SCKn SINn		0	—	ns
SOUT \rightarrow SCK \downarrow delay time	t_{SOVLI}	SCKn SOUTn		$2t_{CYCP} - 30$	—	ns
Serial clock "L" pulse width	t_{LSLH}	SCKn	External shift clock operation	$2t_{CYCP} - 10$	—	ns
Serial clock "H" pulse width	t_{HSL}	SCKn		$t_{CYCP} + 10$	—	ns
SCK \uparrow \rightarrow SOUT delay time	t_{SHOVE}	SCKn SOUTn		—	48	ns
SIN \rightarrow SCK \downarrow setup time	t_{IVSLE}	SCKn SINn		25	—	ns
SCK \downarrow \rightarrow SIN hold time	t_{SLIXE}	SCKn SINn		20	—	ns
SCK fall time	t_F	SCKn		—	5	ns
SCK rise time	t_R	SCKn		—	5	ns

Notes: • The above standards apply to CLK synchronous mode.

- t_{CYCP} indicates the peripheral clock cycle time.
- When the external load capacitance $C = 50$ pF.

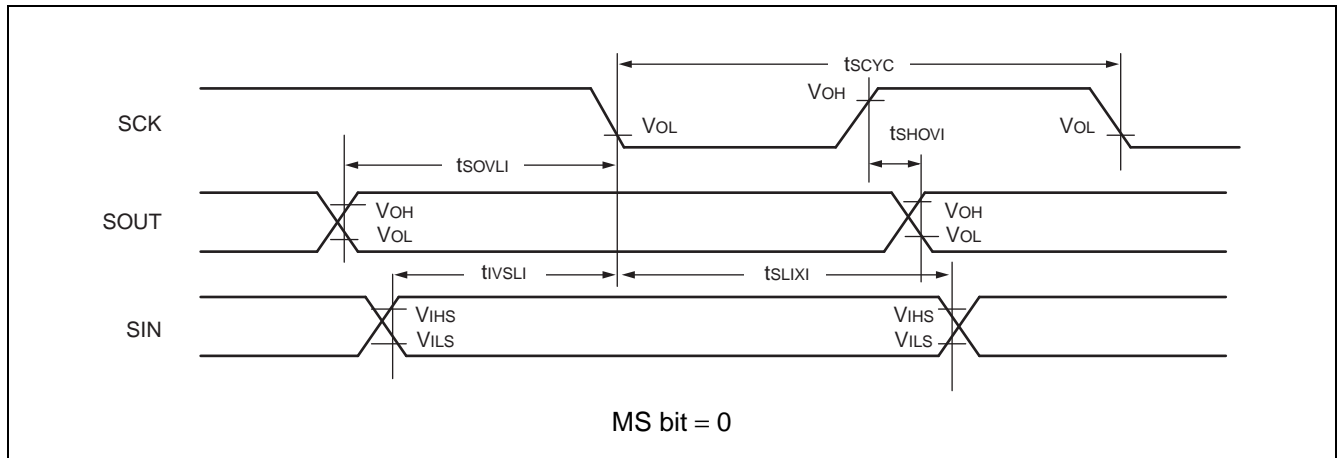

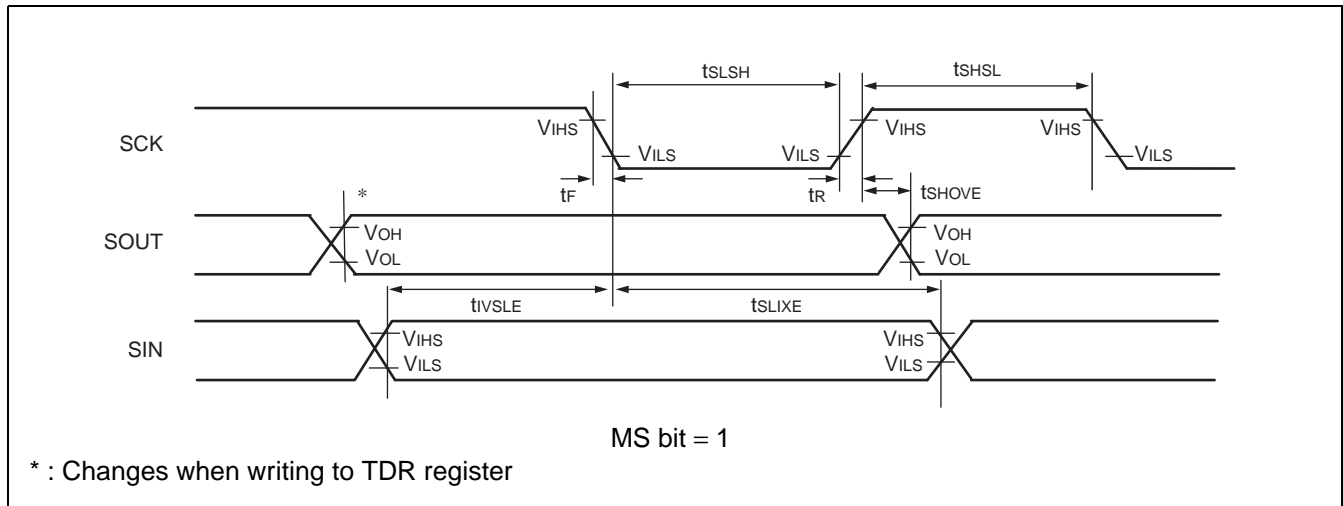

• Synchronous serial (SPI = 1, SCINV = 1)

Parameter	Symbol	Pin name	Conditions	Value		Unit
				Min	Max	
Serial clock cycle time	t_{SCYC}	SCKn	Internal shift clock operation	$4t_{CYCP}$	—	ns
SCK ↓ → SOUT delay time	t_{SLOVI}	SCKn SOUTn		- 30	+ 30	ns
SIN → SCK ↑ setup time	t_{IVSHI}	SCKn SINn		57	—	ns
SCK ↑ → SIN hold time	t_{SHIXI}	SCKn SINn		0	—	ns
SOUT → SCK ↑ delay time	t_{SOVHI}	SCKn SOUTn		$2t_{CYCP} - 30$	—	ns
Serial clock "L" pulse width	t_{SLSH}	SCKn		$2t_{CYCP} - 10$	—	ns
Serial clock "H" pulse width	t_{SHSL}	SCKn	External shift clock operation	$t_{CYCP} + 10$	—	ns
SCK ↓ → SOUT delay time	t_{SLOVE}	SCKn SOUTn		—	48	ns
SIN → SCK ↑ setup time	t_{IVSHE}	SCKn SINn		25	—	ns
SCK ↑ → SIN hold time	t_{SHIXE}	SCKn SINn		20	—	ns
SCK fall time	t_F	SCKn		—	5	ns
SCK rise time	t_R	SCKn		—	5	ns

Notes: • The above standards apply to CLK synchronous mode.

- t_{CYCP} indicates the peripheral clock cycle time.
- When the external load capacitance $C = 50$ pF.

MB91660 Series

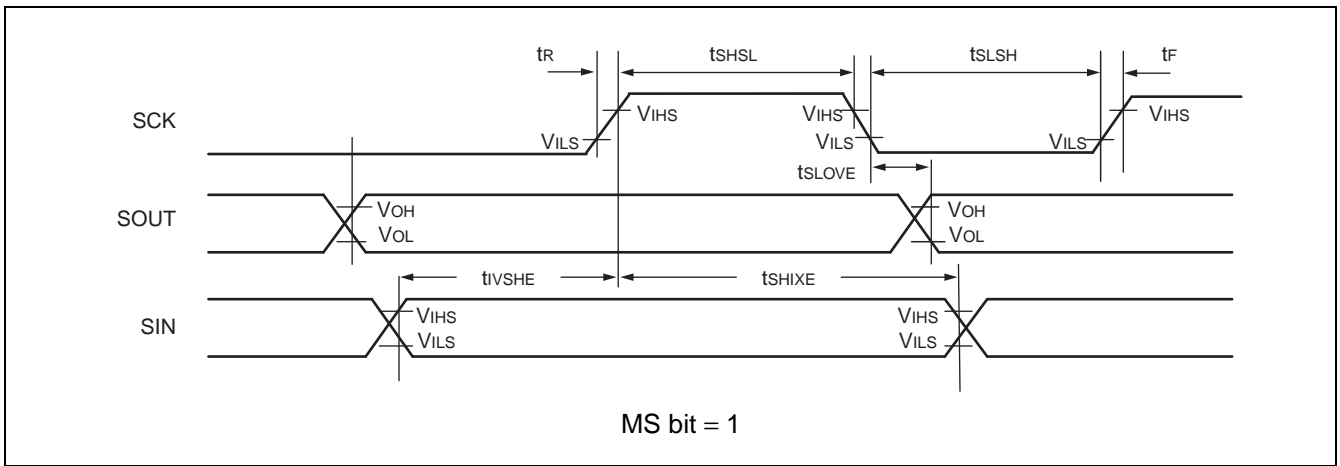
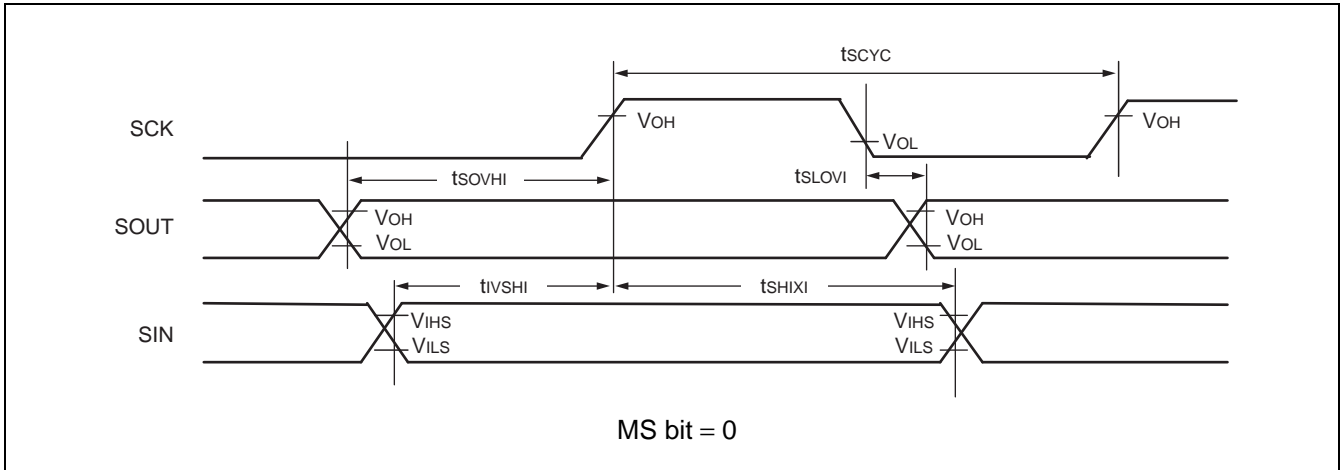

• External clock (EXT = 1) : asynchronous only

Parameter	Symbol	Conditions	Value		Unit
			Min	Max	
Serial clock "L" pulse width	t_{SLSH}	$C_L = 50 \text{ pF}$	$t_{CYCP} + 10$	—	ns
Serial clock "H" pulse width	t_{SHSL}		$t_{CYCP} + 10$	—	ns
SCK fall time	t_f		—	5	ns
SCK rise time	t_r		—	5	ns

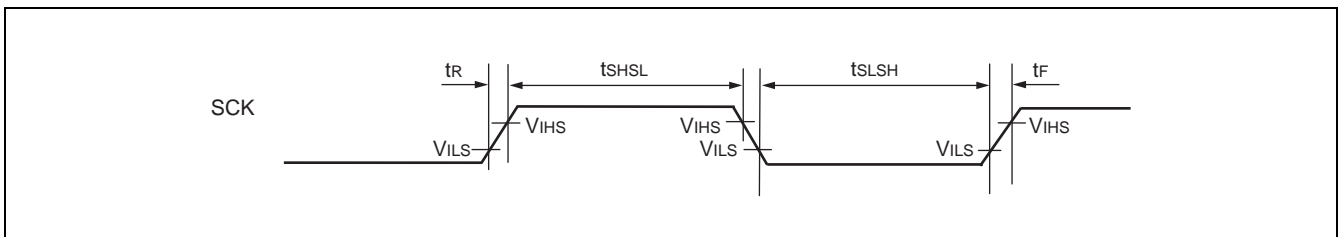

(13) Free-run Timer Clock, Reload Timer Event Input, Up/down Counter Input, Input Capture Input, Interrupt Input Timing

Not using USB : ($V_{CC} = AV_{CC} = 2.7\text{ V to }3.6\text{ V}$, $V_{SS} = AV_{SS} = 0\text{ V}$, $T_a = -40\text{ }^\circ\text{C to }+85\text{ }^\circ\text{C}$)

Using USB : ($V_{CC} = AV_{CC} = 3.0\text{ V to }3.6\text{ V}$, $V_{SS} = AV_{SS} = 0\text{ V}$, $T_a = -40\text{ }^\circ\text{C to }+85\text{ }^\circ\text{C}$)

Parameter	Symbol	Pin name	Condi- tions	Value		Unit	Remarks
				Min	Max		
Input pulse width	t_{TIWH} t_{TIWL}	FRCKn TMIn INn AINn BINn ZINn	—	$2 t_{CYCP}$	—	ns	*1
		INTn	—	$3 t_{CYCP}$	—	ns	*1
			—	1.0	—	μs	*2

*1 : t_{CYCP} indicates peripheral clock cycle time, except when in stop mode, in main timer mode and in watch mode.

*2 : When in stop mode, in main timer mode, or in watch mode.

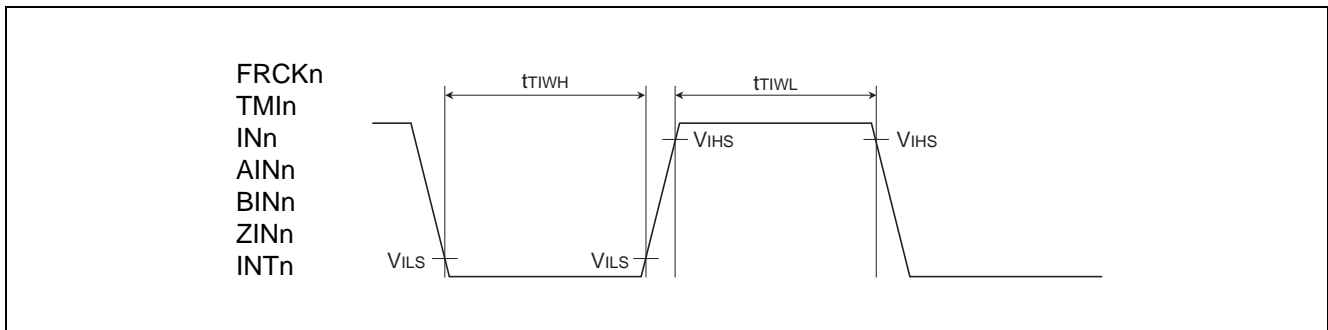

(14) A/D Converter Trigger Input Timing

Not using USB : ($V_{CC} = AV_{CC} = 2.7\text{ V to }3.6\text{ V}$, $V_{SS} = AV_{SS} = 0\text{ V}$, $T_a = -40\text{ }^\circ\text{C to }+85\text{ }^\circ\text{C}$)

Using USB : ($V_{CC} = AV_{CC} = 3.0\text{ V to }3.6\text{ V}$, $V_{SS} = AV_{SS} = 0\text{ V}$, $T_a = -40\text{ }^\circ\text{C to }+85\text{ }^\circ\text{C}$)

Parameter	Symbol	Pin name	Condi- tions	Value		Unit	Remarks
				Min	Max		
A/D converter trigger input	t_{TADTGL} t_{TADTGH}	ADTRGn	—	$2 t_{CYCP}$	—	ns	*

* : t_{CYCP} indicates peripheral clock cycle time.

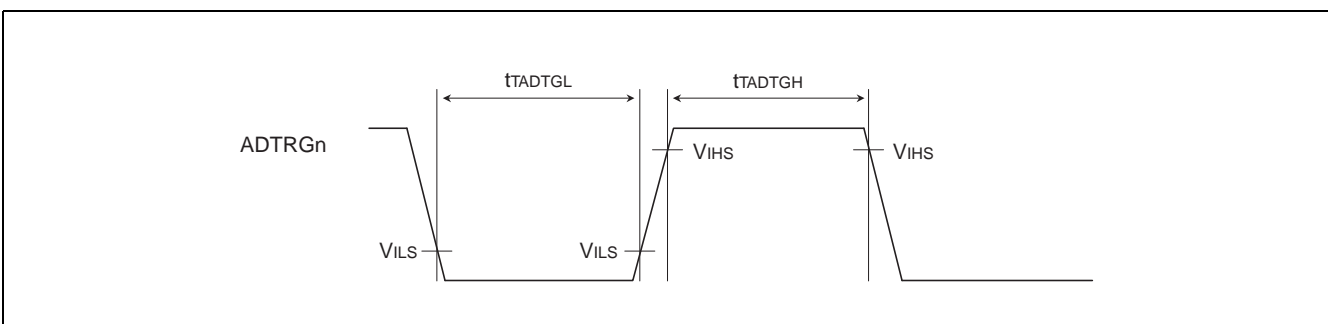

MB91660 Series

(15) I²C Timing

Not using USB : ($V_{CC} = AV_{CC} = 2.7\text{ V to }3.6\text{ V}$, $V_{SS} = AV_{SS} = 0\text{ V}$, $T_a = -40\text{ }^\circ\text{C to }+85\text{ }^\circ\text{C}$)

Using USB : ($V_{CC} = AV_{CC} = 3.0\text{ V to }3.6\text{ V}$, $V_{SS} = AV_{SS} = 0\text{ V}$, $T_a = -40\text{ }^\circ\text{C to }+85\text{ }^\circ\text{C}$)

Parameter	Symbol	Pin name	Condi- tions	Typical mode		High-speed mode ^{*3}		Unit
				Min	Max	Min	Max	
SCL clock frequency	f_{SCL}	SCKn (SCLn)	$C_L = 50\text{ pF}$, $R = (V_p/I_{OL})^{*1}$	0	100	0	400	kHz
“(Repeated) START condition” hold time SDA ↓ → SCL ↓	t_{HDSTA}	SOUTn (SDAn) SCKn (SCLn)		4.0	—	0.6	—	μs
SCL clock “L” width	t_{LOW}	SCKn (SCLn)		4.7	—	1.3	—	μs
SCL clock “H” width	t_{HIGH}	SCKn (SCLn)		4.0	—	0.6	—	μs
“(Repeated) START condition” setup time SCL ↑ → SDA ↓	t_{SUSTA}	SCKn (SCLn)		4.7	—	0.6	—	μs
Data hold time SCL ↓ → SDA ↓ ↑	t_{HDDAT}	SOUTn (SDAn) SCKn (SCLn)		0	3.45^{*2}	0	0.9^{*3}	μs
Data setup time SDA ↓ ↑ → SCL ↑	t_{SUDAT}	SOUTn (SDAn) SCKn (SCLn)		250	—	100	—	ns
“(STOP condition” setup time SCL ↑ → SDA ↑	t_{SUSTO}	SOUTn (SDAn) SCKn (SCLn)		4.0	—	0.6	—	μs
Bus free time between “(STOP condition” and “(START condition”	t_{BUF}	—		4.7	—	1.3	—	μs
Noise filter	t_{SP}	—	—	$2 t_{CYCP}^{*4}$	—	$2 t_{CYCP}^{*4}$	—	ns

*1 : R and C represent the pull-up resistance and load capacitance of the SCL and SDA lines, respectively. V_p indicates the power supply voltage of the pull-up resistance and I_{OL} indicates V_{OL} guaranteed current.

*2 : The maximum t_{HDDAT} must satisfy that it doesn't extend at least “L” period (t_{LOW}) of device's SCL signal.

*3 : A high-speed mode I²C bus device can be used on a standard mode I²C bus system as long as the device satisfies the requirement of “ $t_{SUDAT} \geq 250\text{ ns}$ ”.

*4 : t_{CYCP} is the peripheral clock cycle time. To use I²C, set the peripheral bus clock at 8 MHz or more.

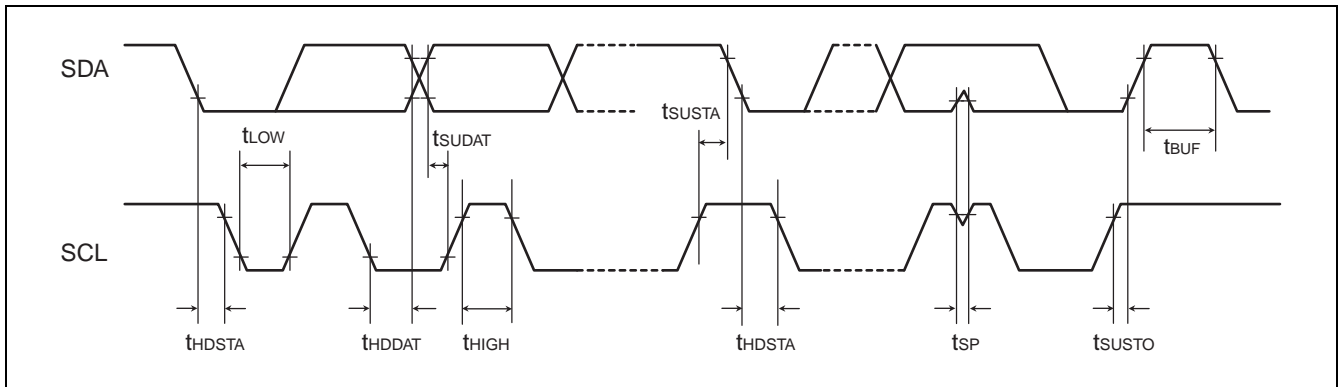

MB91660 Series

(16) Slave Interface

- Read Access

Not using USB : ($V_{CC} = AV_{CC} = 2.7\text{ V to }3.6\text{ V}$, $V_{SS} = AV_{SS} = 0\text{ V}$, $T_a = -40\text{ }^\circ\text{C to }+85\text{ }^\circ\text{C}$)

Using USB : ($V_{CC} = AV_{CC} = 3.0\text{ V to }3.6\text{ V}$, $V_{SS} = AV_{SS} = 0\text{ V}$, $T_a = -40\text{ }^\circ\text{C to }+85\text{ }^\circ\text{C}$)

Parameter	Symbol	Pin name	Conditions	Value		Unit
				Min	Max	
SIF read cycle time	texrc	SIFAn, $\overline{\text{SIFCSn}}$	—	$6 \times \text{tcyc}$	—	ns
SIFA → data valid	texadv	SIFAn, SIFDn	—	$5 \times \text{tcyc}$	—	ns
SIFCS → data valid	texcsdv	$\overline{\text{SIFCSn}}$, SIFDn	—	$5 \times \text{tcyc}$	—	ns
SIFRD → data output enable	texdoe	$\overline{\text{SIFRDn}}$, SIFDn	—	$5 \times \text{tcyc}$	—	ns
SIFRD "H" → Hi-Z	texdzh	$\overline{\text{SIFRDn}}$, SIFDn	—	—	$5 \times \text{tcyc} + 8$	ns

Note: tcyc indicates one cycle of on-chip bus clock.

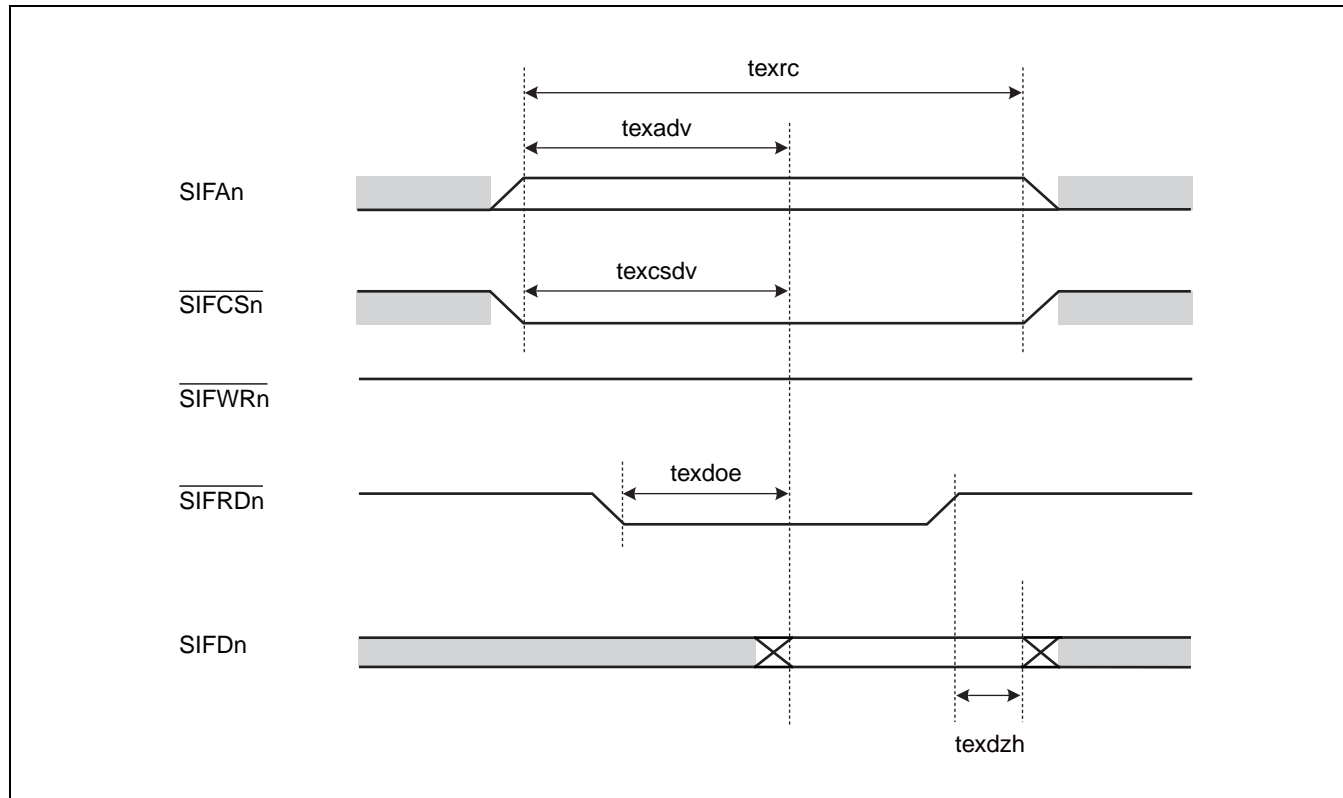

• Write Access

Not using USB : ($V_{CC} = AV_{CC} = 2.7\text{ V to }3.6\text{ V}$, $V_{SS} = AV_{SS} = 0\text{ V}$, $T_a = -40\text{ }^\circ\text{C to }+85\text{ }^\circ\text{C}$)

Using USB : ($V_{CC} = AV_{CC} = 3.0\text{ V to }3.6\text{ V}$, $V_{SS} = AV_{SS} = 0\text{ V}$, $T_a = -40\text{ }^\circ\text{C to }+85\text{ }^\circ\text{C}$)

Parameter	Symbol	Pin name	Conditions	Value		Unit
				Min	Max	
SIF write cycle time	texwc	SIFAn, $\overline{\text{SIFCSn}}$	—	$5 \times t_{\text{CYC}}$	—	ns
SIFA → data setup time	texads	SIFAn, SIFDn	—	$4 \times t_{\text{CYC}}$	—	ns
SIFCS → data setup time	texcsds	$\overline{\text{SIFCSn}}$, SIFDn	—	$4 \times t_{\text{CYC}}$	—	ns
SIFWR “L” pulse width	texwp	$\overline{\text{SIFWRn}}$, SIFDn	—	$4 \times t_{\text{CYC}}$	—	ns
SIFD setup time	texds	$\overline{\text{SIFWRn}}$, SIFDn	—	$2 \times t_{\text{CYC}}$	—	ns
SIFD hold time	texdh	$\overline{\text{SIFWRn}}$, SIFDn	—	0	—	ns

Note: t_{CYC} indicates one cycle of on-chip bus clock.

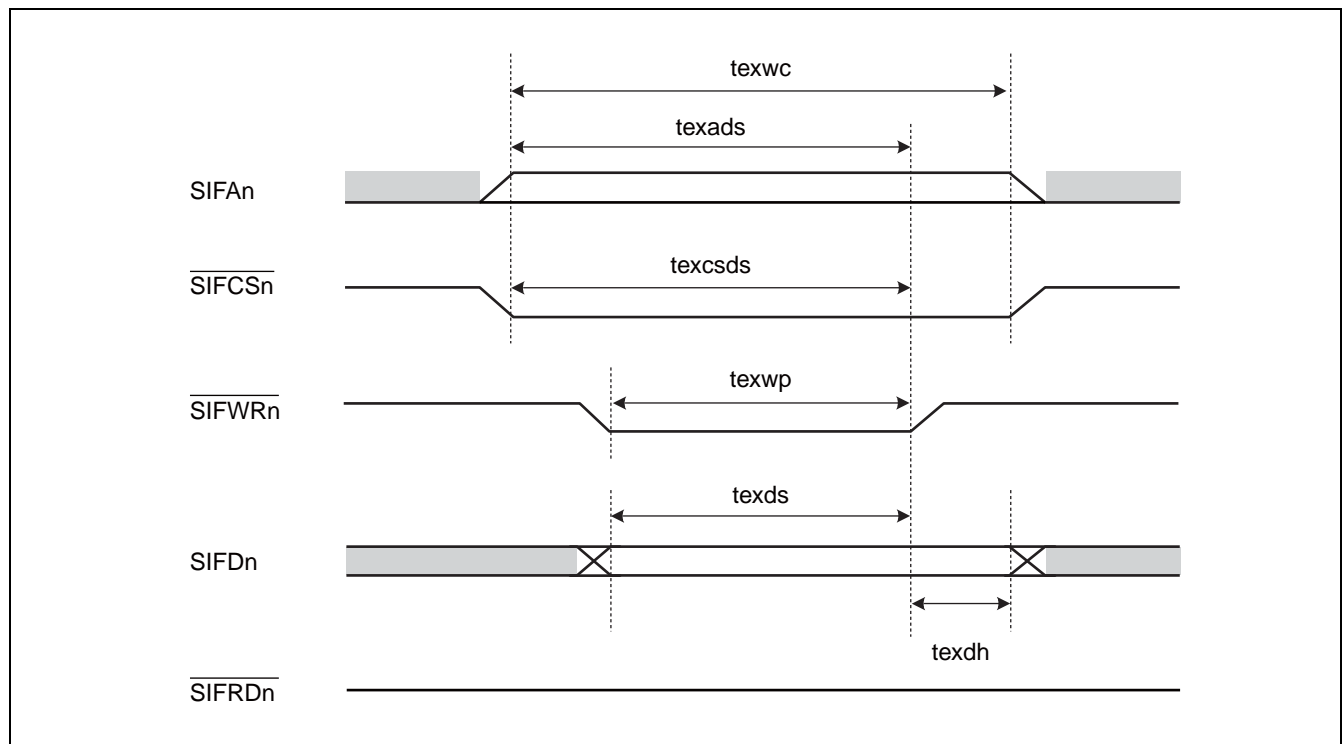

MB91660 Series

5. Electrical Characteristics for the A/D Converter

Not using USB : ($V_{CC} = AV_{CC} = 2.7\text{ V}$ to 3.6 V , $V_{SS} = AV_{SS} = 0\text{ V}$, $T_a = -40\text{ }^\circ\text{C}$ to $+85\text{ }^\circ\text{C}$)

Using USB : ($V_{CC} = AV_{CC} = 3.0\text{ V}$ to 3.6 V , $V_{SS} = AV_{SS} = 0\text{ V}$, $T_a = -40\text{ }^\circ\text{C}$ to $+85\text{ }^\circ\text{C}$)

Parameter	Pin name	Value			Unit	Remarks
		Min	Typ	Max		
Resolution	—	—	—	10	bit	
Total error	—	- 5	—	+ 5	LSB	AV _{CC} = 3.3 V, AVRH = 3.3 V
Linearity error	—	- 3.5	—	+ 3.5	LSB	
Differential linearity error	—	- 3	—	+ 3	LSB	
Zero transition voltage	AN0 to AN23	- 1.5	+ 0.5	+ 4	LSB	
Full transition voltage	AN0 to AN23	AVRH - 4	AVRH - 1.5	AVRH + 0.5	LSB	
Compare time	—	0.72* ³	—	—	μs	PCLK = 33 MHz
Conversion time	—	1.2* ¹	—	—	μs	PCLK = 33 MHz
Power supply current (analog + digital)	AV _{CC}	—	—	3.5	mA	D/A stopped
		—	—	11	μA	At power-down* ²
Reference power supply current (between AVRH and AV _{SS})	AVRH	—	—	0.6	mA	AVRH = 3.0 V
		—	—	5	μA	At power-down* ²
Analog input capacity	—	—	—	8.5	pF	
Interchannel disparity	—	—	—	4	LSB	
Analog port input current	AN0 to AN23	—	—	10	μA	
Analog input voltage	AN0 to AN23	AV _{SS}	—	AVRH	V	
Standard voltage	AVRH	AV _{SS}	—	AV _{CC}	V	

*1 : Depending on the clock cycle supplied to peripheral resources.

Ensure that it satisfies the value; PCLK cycle × more than 4 + the value calculated from (Equation 1).

The condition of the minimum conversion time is when PCLK = 33 MHz, the value of sampling time: 0.424 μs, external impedance: 1.4 kΩ or less and compare time: 0.72 μs.

(Continued)

(Continued)

*2 : The current when the CPU is in stop mode and the A/D converter is not operating.

*3 : Compare time = $\{(CT + 1) \times 10 + 4\} \times$ peripheral clock (PCLK) period. (CT indicates compare time setting bits.)
The condition of the minimum compare time is when CT = 1 and PCLK = 33 MHz.

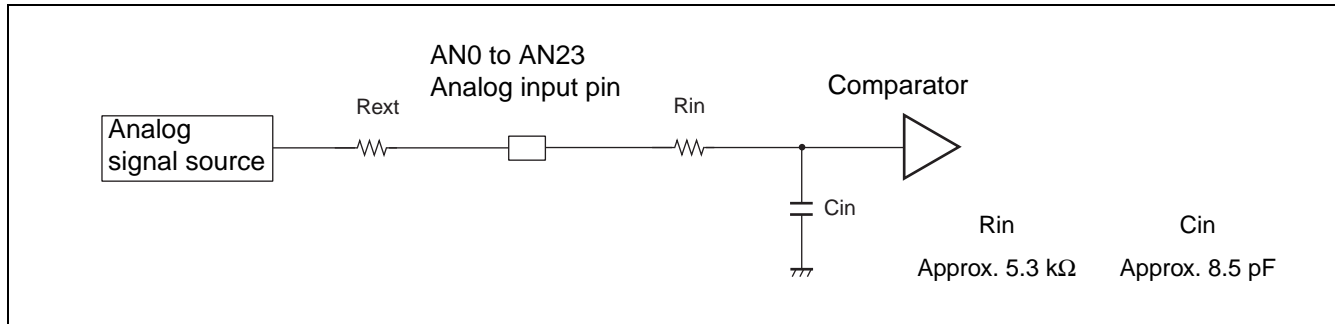

The output impedance of the external circuit connected to the analog input affects the sampling time of the A/D converter. Design the output impedance of the output circuit such that the required sampling time is less than the value of T_s calculated from the following equation.

(Equation 1) $T_s = (R_{in} + R_{ext}) \times C_{in} \times 8$

T_s : Sampling time
 R_{in} : Input resistance of A/D = 5.3 kΩ
 C_{in} : Input capacitance of A/D = 8.5 pF
 R_{ext} : Output impedance of external circuit

If the sampling time is set as 600 ns,
 $600 \text{ ns} \geq (5.3 \text{ k}\Omega + R_{ext}) \times 8.5 \text{ pF} \times 8$
 $\therefore R_{ext} \leq 3.5 \text{ k}\Omega$

And the impedance of the external circuit therefore needs to be 3.5 kΩ or less.

MB91660 Series

• Definition of 10-bit A/D Converter Terms

- Resolution : Analog variation that is recognized by an A/D converter.
- Linearity error : Deviation of the line between the zero-transition point (0000000000←→0000000001) and the full-scale transition point (1111111110←→1111111111) from the actual conversion characteristics.
- Differential linearity error : Deviation from the ideal value of the input voltage that is required to change the output code by 1 LSB.
- Total error : Difference between the actual value and the theoretical value. The total error includes zero transition error, full-scale transition error, and linear error.

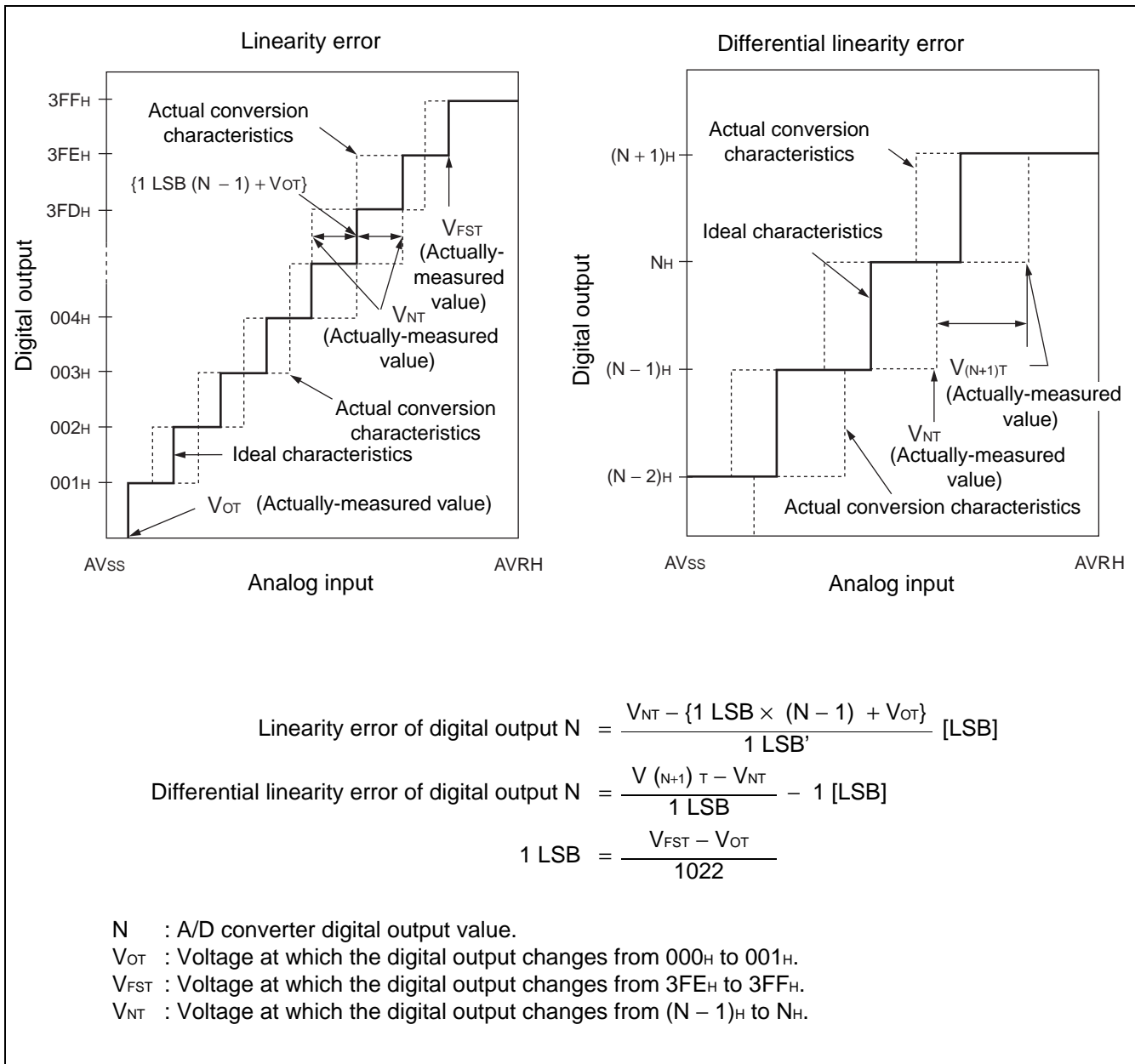

(Continued)

(Continued)

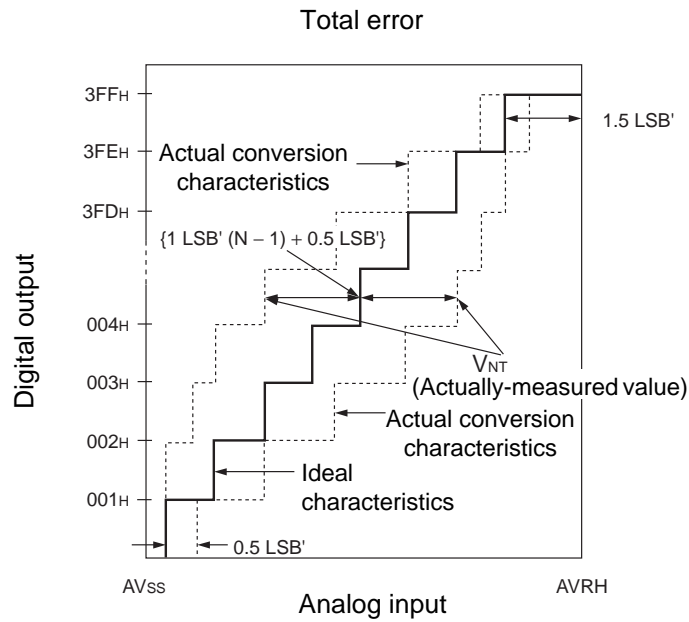

$$1 \text{ LSB}' (\text{Ideal value}) = \frac{\text{AVRH} - \text{AVss}}{1024} [\text{V}]$$

$$\text{Total error of digital output } N = \frac{V_{\text{NT}} - \{1 \text{ LSB}' \times (N - 1) + 0.5 \text{ LSB}'\}}{1 \text{ LSB}'}$$

N : A/D converter digital output value.

V_{NT} : Voltage at which the digital output changes from $(N + 1)_H$ to N_H .

$V_{\text{OT}'}$ (Ideal value) = $\text{AVss} + 0.5 \text{ LSB}$ [V]

$V_{\text{FST}'}$ (Ideal value) = $\text{AVRH} - 1.5 \text{ LSB}$ [V]

MB91660 Series

6. Electrical Characteristics for the D/A Converter

Not using USB : ($V_{CC} = AV_{CC} = 2.7\text{ V}$ to 3.6 V , $V_{SS} = AV_{SS} = 0\text{ V}$, $T_a = -40\text{ }^\circ\text{C}$ to $+85\text{ }^\circ\text{C}$)

Using USB : ($V_{CC} = AV_{CC} = 3.0\text{ V}$ to 3.6 V , $V_{SS} = AV_{SS} = 0\text{ V}$, $T_a = -40\text{ }^\circ\text{C}$ to $+85\text{ }^\circ\text{C}$)

Parameter	Pin name	Value			Unit	Remarks
		Min	Typ	Max		
Resolution	—	—	—	8	bit	
Linear error	—	- 2.0	—	+ 2.0	LSB	When the output is unloaded
Differential linearity error	—	- 1.0	—	+ 1.0	LSB	When the output is unloaded
Conversion time	—	—	0.6	—	μs	When load capacitance (C_L) = 20 pF
		—	3.0	—	μs	When load capacitance (C_L) = 100 pF
Analog output impedance	DA0 to DA2	3.19	3.51	5.85	k Ω	
Analog current	AV_{CC}	—	450	—	μA	10 μs conversion, when the output is unloaded (When 3 channels operating, A/D stopped)
		—	—	3600*	μA	When the input digital code is fixed at 7A _H or 85 _H (When 3 channels operating, A/D stopped)
		—	—	11	μA	At power-down (When A/D stopped)

* : The current consumption of the D/A converter varies with input digital code.
The standard value indicates the current consumed when the digital code that maximizes the current consumption is input.

7. USB Characteristics

($V_{CC} = AV_{CC} = 3.0\text{ V to }3.6\text{ V}$, $V_{SS} = AV_{SS} = 0\text{ V}$, $T_a = -40\text{ }^\circ\text{C to }+85\text{ }^\circ\text{C}$)

Parameter		Symbol	Pin name	Conditions	Value		Unit	Remarks
					Min	Max		
Input characteristics	Input High level voltage	V_{IH}	UDP, UDM	—	2.0	$V_{CC} + 0.3$	V	*1
	Input Low level voltage	V_{IL}		—	$V_{SS} - 0.3$	0.8	V	*1
	Differential input sensitivity	V_{DI}		—	0.2	—	V	*2
	Differential common mode input voltage	V_{CM}		—	0.8	2.5	V	*2
Output characteristics	Output High level voltage	V_{OH}		External pull-down resistance = 15 k Ω	2.8	3.6	V	*3
	Output Low level voltage	V_{OL}		External pull-up resistance = 1.5 k Ω	0.0	0.3	V	*3
	Crossover voltage	V_{CRS}		—	1.3	2.0	V	*4
	Rise time	t_{FR}		—	4	20	nS	*5
	Fall time	t_{FF}	—	4	20	nS	*5	
	Rise/fall time matching	t_{RFM}	—	90	111.11	%	*5	
	Output impedance	Z_{DRV}	—	28	44	Ω	Including $R_s = 27\ \Omega$	
Input capacitance	Transceiver edge rate control capacitance	C_{EDGE}	—	—	75	pF	*6	
Series resistance		R_s	—	25	30	Ω	Recommended value: 27 Ω	

*1 : The switching threshold voltage of Single-End-Receiver of USB I/O buffer is set as within V_{IL} (Max) = 0.8 [V], V_{IH} (Min) = 2.0 [V] (TTL input standard).
There are some hystereses to lower noise sensitivity.

(Continued)

MB91660 Series

- *2 : Use differential-Receiver to receive USB differential data signal.
 Differential-Receiver has 200 [mV] of differential input sensitivity when the differential data input is within 0.8 [V] to 2.5 [V] to the local ground reference level.
 Above voltage range is the common mode input voltage range.

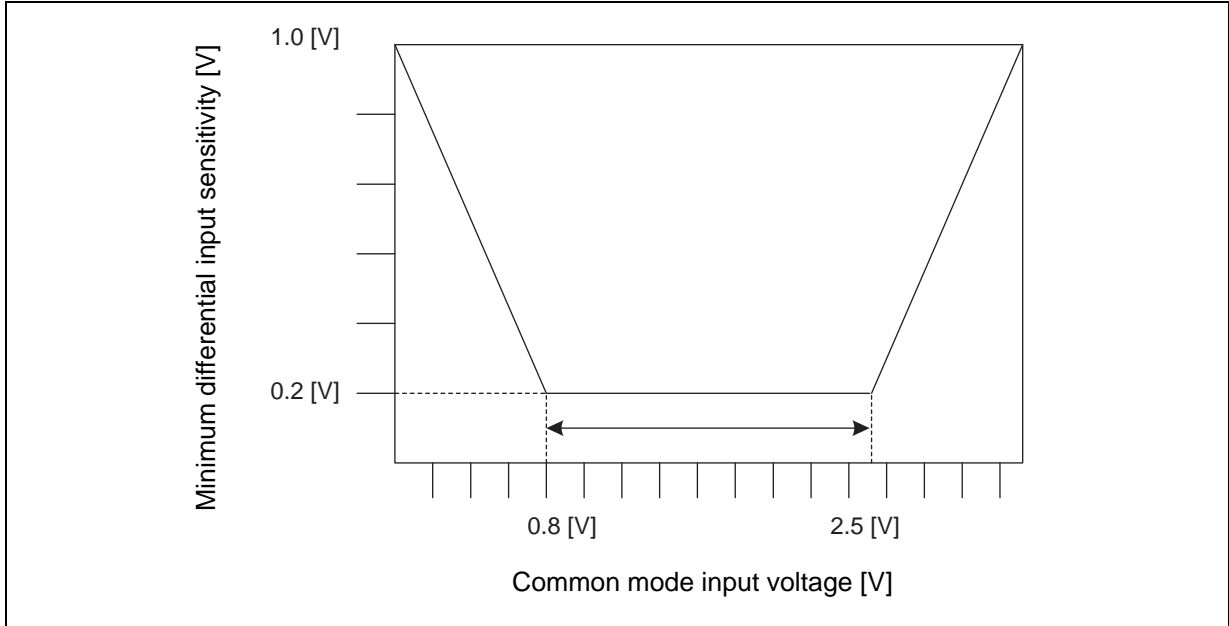

- *3 : The output drive capability of the driver is below 0.3 [V] at Low-State (V_{OL}) (to 3.6 [V] and 1.5 k Ω load), and 2.8 [V] or above (to the V_{SS} and 1.5 k Ω load) at High-State (V_{OH}).
 *4 : The cross voltage of the external differential output signal ($D+ / D-$) of USB I/O buffer is within 1.3 [V] to 2.0 [V].

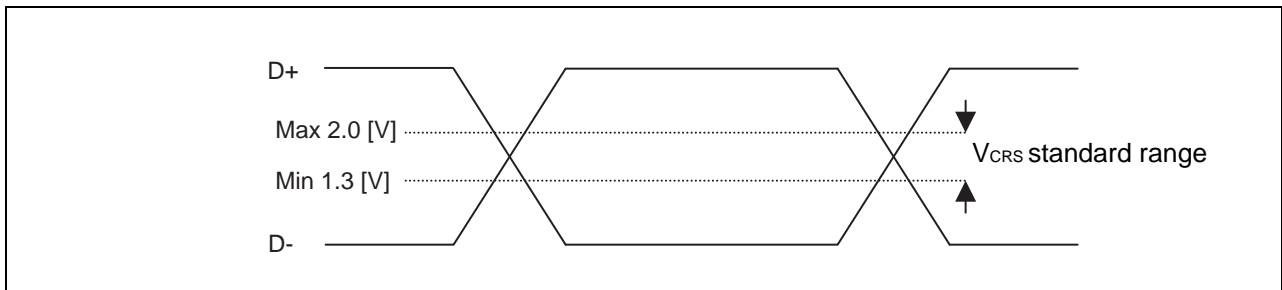

- *5 : Regarding t_{FR} , t_{FF} , t_{RFM}
 They indicate rise time (T_{rise}) and fall time (T_{fall}) of the differential data signal.
 They are defined by the time between 10% to 90% of the output signal voltage.
 For full-speed buffer, t_{FR}/t_{FF} ratio is regulated as within $\pm 10\%$ to minimize RFI emission.

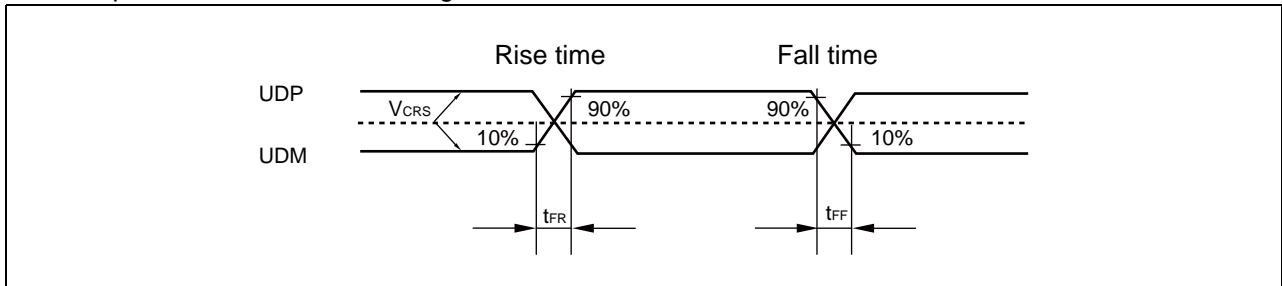

(Continued)

(Continued)

*6 : The place to connect transceiver edge rate control capacitance C_{EDGE}

For this USB I/O, it is recommended to use C_{EDGE} control capacitor.

For USB Max standard as 75 pF, please control the edge characteristic of output waveform by connecting 30 to 50 [pF] (recommended value : 47 [pF] \pm 50[pF]) to D + and D - lines when implementing on the board.

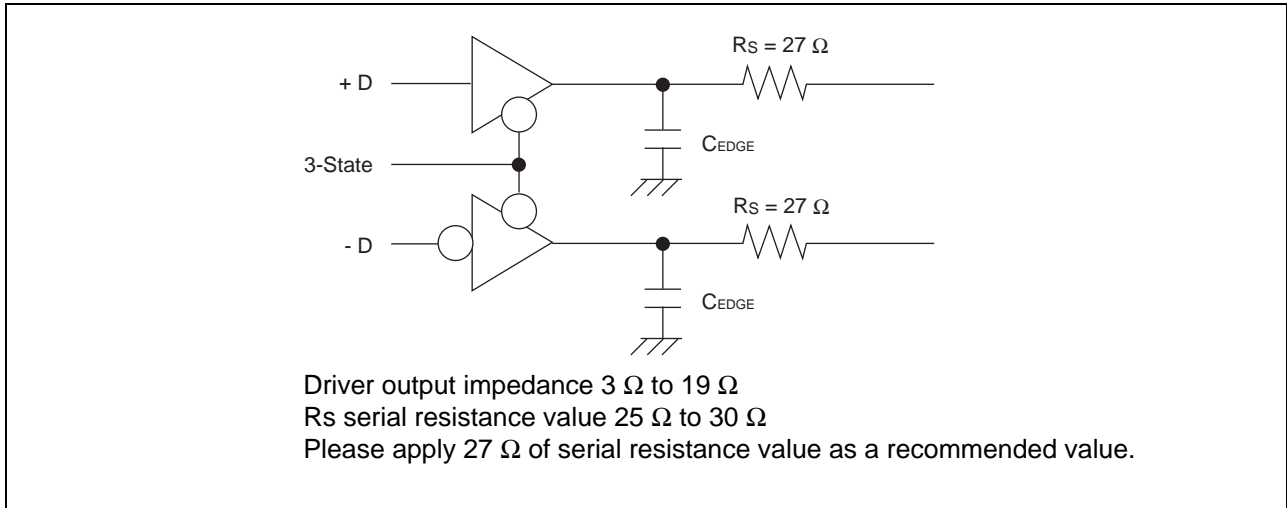

MB91660 Series

8. Flash Memory Write/Erase Characteristics

($V_{CC} = 3.3\text{ V}$, $T_a = +25\text{ °C}$)

Parameter	Value			Unit	Remarks
	Min	Typ	Max		
Sector erase time	—	0.9	3.6	s	Excludes write time prior to internal erase
Half word (16bits) write time	—	23	370	μs	Not including system-level overhead time.
Chip erase time*1	—	10.8	43.2	s	Excludes write time prior to internal erase
Erase/write cycles	10000	—	—	cycle	Average $T_a \leq +85\text{ °C}$
Flash memory data hold time	10^{*2}	—	—	year	Average $T_a \leq +85\text{ °C}$

*1 : The chip erase time is the sector erase time multiplied across all sectors.

*2 : This value comes from the technology qualification (using Arrhenius equation to translate high temperature measurements into normalized value at $+85\text{ °C}$).

■ ORDERING INFORMATION

Part number	Package
MB91F662PMC	120-pin plastic LQFP (FPT-120P-M21)
MB91661PMC	
MB91664PMC	

MB91660 Series

■ PACKAGE DIMENSION

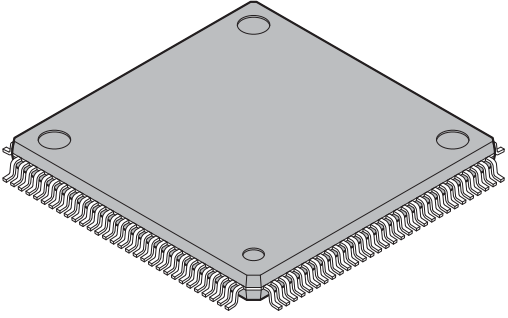
<p>120-pin plastic LQFP</p>  <p>(FPT-120P-M21)</p>	Lead pitch	0.50 mm
	Package width × package length	16.0 × 16.0 mm
	Lead shape	Gullwing
	Sealing method	Plastic mold
	Mounting height	1.70 mm MAX
	Weight	0.88 g
	Code (Reference)	P-LFQFP120-16×16-0.50

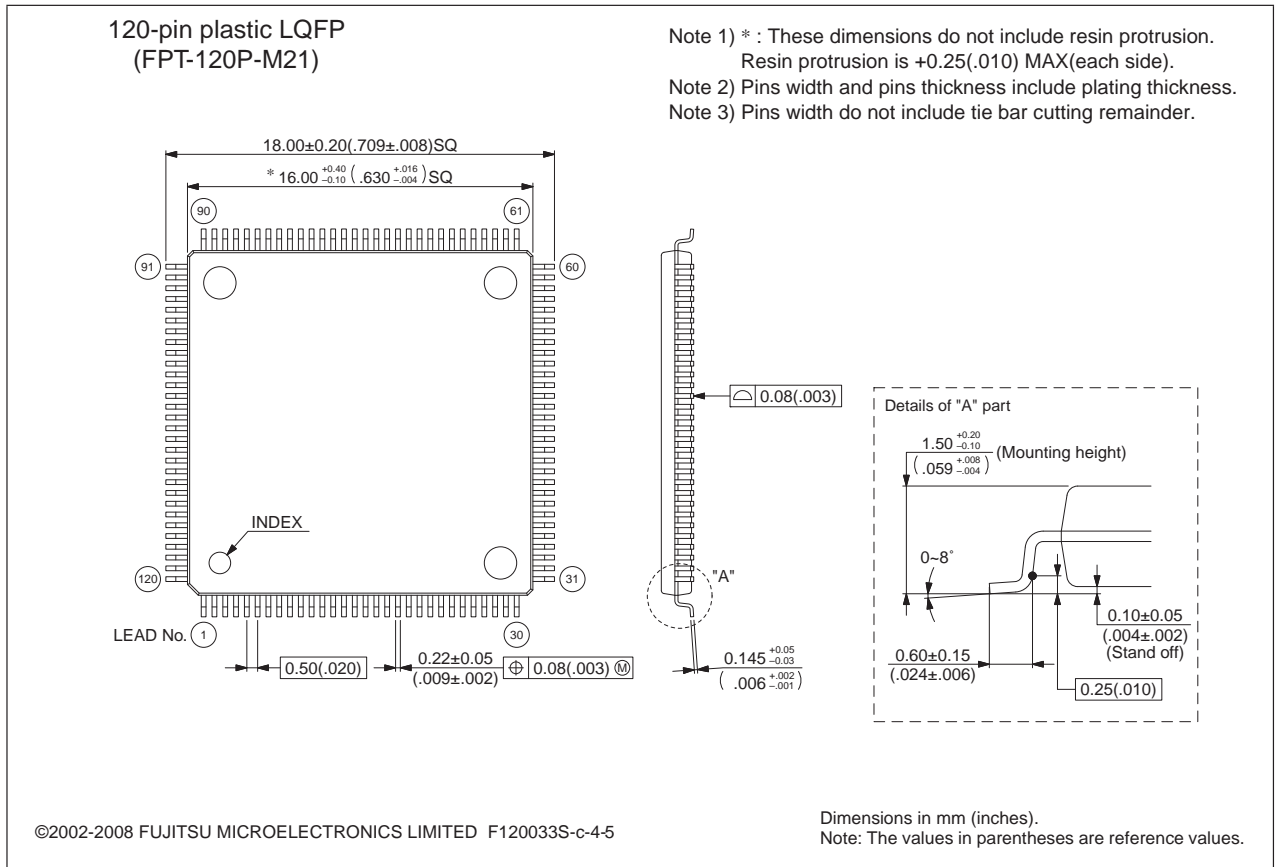

Please confirm the latest Package dimension by following URL.
<http://edevic.fujitsu.com/package/en-search/>

■ MAIN CHANGES IN THIS EDITION

Page	Section	Change Results
—	—	Changed the terms. (USB function with Mini-HOST → USB function/ HOST) (Mini-HOST → HOST)
4	■ FEATURES	Changed the explanation of [USB HOST]. (• Support of bulk and interrupt transfer (Only using endpoint1 and endpoint2) → • Support control transfer, bulk transfer, interrupt transfer, and isochronous transfer)
114	■ ELECTRICAL CHARACTERISTICS 4. AC Characteristics (16) Slave Interface	Corrected from “SIF write cycle time” to “SIF read cycle time”.

The vertical lines marked in the left side of the page show the changes.

MB91660 Series

FUJITSU MICROELECTRONICS LIMITED

Shinjuku Dai-Ichi Seimei Bldg., 7-1, Nishishinjuku 2-chome,
Shinjuku-ku, Tokyo 163-0722, Japan
Tel: +81-3-5322-3329
<http://jp.fujitsu.com/fml/en/>

For further information please contact:

North and South America

FUJITSU MICROELECTRONICS AMERICA, INC.
1250 E. Arques Avenue, M/S 333
Sunnyvale, CA 94085-5401, U.S.A.
Tel: +1-408-737-5600 Fax: +1-408-737-5999
<http://www.fma.fujitsu.com/>

Asia Pacific

FUJITSU MICROELECTRONICS ASIA PTE. LTD.
151 Lorong Chuan,
#05-08 New Tech Park 556741 Singapore
Tel : +65-6281-0770 Fax : +65-6281-0220
<http://www.fmal.fujitsu.com/>

Europe

FUJITSU MICROELECTRONICS EUROPE GmbH
Pittlerstrasse 47, 63225 Langen, Germany
Tel: +49-6103-690-0 Fax: +49-6103-690-122
<http://emea.fujitsu.com/microelectronics/>

FUJITSU MICROELECTRONICS SHANGHAI CO., LTD.

Rm. 3102, Bund Center, No.222 Yan An Road (E),
Shanghai 200002, China
Tel : +86-21-6146-3688 Fax : +86-21-6335-1605
<http://cn.fujitsu.com/fmc/>

Korea

FUJITSU MICROELECTRONICS KOREA LTD.
206 Kosmo Tower Building, 1002 Daechi-Dong,
Gangnam-Gu, Seoul 135-280, Republic of Korea
Tel: +82-2-3484-7100 Fax: +82-2-3484-7111
<http://kr.fujitsu.com/fmk/>

FUJITSU MICROELECTRONICS PACIFIC ASIA LTD.

10/F., World Commerce Centre, 11 Canton Road,
Tsimshatsui, Kowloon, Hong Kong
Tel : +852-2377-0226 Fax : +852-2376-3269
<http://cn.fujitsu.com/fmc/en/>

Specifications are subject to change without notice. For further information please contact each office.

All Rights Reserved.

The contents of this document are subject to change without notice.

Customers are advised to consult with sales representatives before ordering.

The information, such as descriptions of function and application circuit examples, in this document are presented solely for the purpose of reference to show examples of operations and uses of FUJITSU MICROELECTRONICS device; FUJITSU MICROELECTRONICS does not warrant proper operation of the device with respect to use based on such information. When you develop equipment incorporating the device based on such information, you must assume any responsibility arising out of such use of the information.

FUJITSU MICROELECTRONICS assumes no liability for any damages whatsoever arising out of the use of the information.

Any information in this document, including descriptions of function and schematic diagrams, shall not be construed as license of the use or exercise of any intellectual property right, such as patent right or copyright, or any other right of FUJITSU MICROELECTRONICS or any third party or does FUJITSU MICROELECTRONICS warrant non-infringement of any third-party's intellectual property right or other right by using such information. FUJITSU MICROELECTRONICS assumes no liability for any infringement of the intellectual property rights or other rights of third parties which would result from the use of information contained herein.

The products described in this document are designed, developed and manufactured as contemplated for general use, including without limitation, ordinary industrial use, general office use, personal use, and household use, but are not designed, developed and manufactured as contemplated (1) for use accompanying fatal risks or dangers that, unless extremely high safety is secured, could have a serious effect to the public, and could lead directly to death, personal injury, severe physical damage or other loss (i.e., nuclear reaction control in nuclear facility, aircraft flight control, air traffic control, mass transport control, medical life support system, missile launch control in weapon system), or (2) for use requiring extremely high reliability (i.e., submersible repeater and artificial satellite).

Please note that FUJITSU MICROELECTRONICS will not be liable against you and/or any third party for any claims or damages arising in connection with above-mentioned uses of the products.

Any semiconductor devices have an inherent chance of failure. You must protect against injury, damage or loss from such failures by incorporating safety design measures into your facility and equipment such as redundancy, fire protection, and prevention of over-current levels and other abnormal operating conditions.

Exportation/release of any products described in this document may require necessary procedures in accordance with the regulations of the Foreign Exchange and Foreign Trade Control Law of Japan and/or US export control laws.

The company names and brand names herein are the trademarks or registered trademarks of their respective owners.