

120mm sq.

San Ace 120

25mm thick (G type), 38mm thick (GV type)
38mm thick (G type), 38mm thick (SG type)



General Specifications With a pulse sensor Specifications for pulse sensors ⇔ Refer to Page 307

With PWM speed control function

- Material Frame: Plastics (Flammability: UL94V-0),
Impeller: Plastics (Flammability: UL94V-1)
- Life Expectancy Varies for each model (L10: Survival rate: 90% at 60°C, rated voltage, and continuously run in a free air state)
- Lead Wire ⊕ red ⊖ black Sensor yellow Control brown
- Storage Temperature -30°C to +70°C (Non-condensing)

120×120×38mm (Mass : 360g) GV type

Specifications The numbers in () represent ribless models.

Model No.	Rated Voltage [V]	Operating Voltage Range [V]	PWM duty cycle※ [%]	Rated Current [A]	Rated Input [W]	Rated Speed [min ⁻¹]	Air Flow [m ³ /min] [CFM]		Static Pressure [Pa] [inchH ₂ O]		SPL [dB(A)]	Operating Temperature [°C]	Life Expectancy [h]
9GV1212P1J01(011)	12	10.2 to 13.8	100	3.00	36.00	6,400	6.35	224.0	360.0	1.45	64	-10 to +70	40,000
			0	0.19	2.28	1,500	1.49	52.6	19.8	0.08	33		
9GV1248P1J01	48	40.8 to 55.2	100	0.75	36	6,400	6.35	224.0	360.0	1.45	64		
			0	0.06	2.88	1,500	1.49	52.6	26.1	0.106	33		

※PWM Frequency : 25kHz

Without Sensor Pulse Sensor PWM Control Available in all models.

Dimensions (Unit : mm) (With ribs)

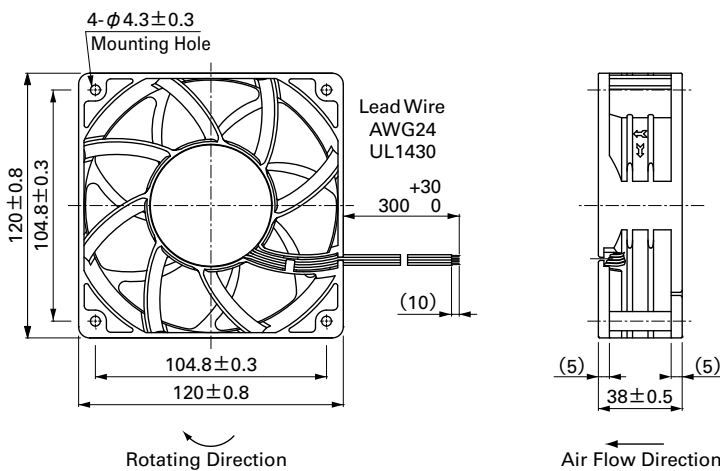

Reference dimension of mounting holes and vent opening (Unit : mm)

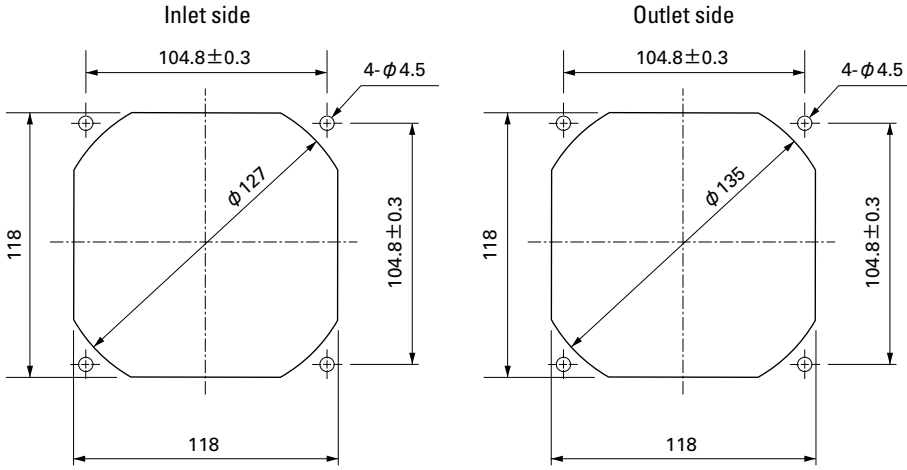

Options (Unit : mm)

Finger guards

Model : 109-019C Surface treatment : Nickel-chrome plating (silver) Color : 109-019H : Cation electropainting (black)

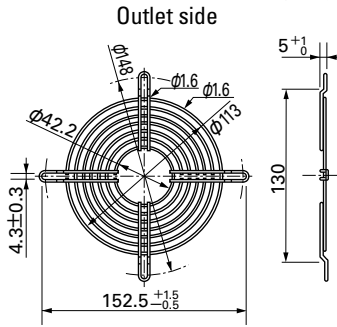

Resin finger guards

Model : 109-1000G

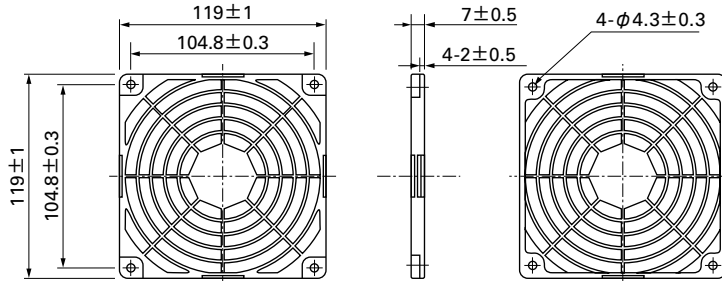

Model : 109-019E Surface treatment : Nickel-chrome plating (silver) Color : 109-019K : Cation electropainting (black)

Inlet side, Outlet side

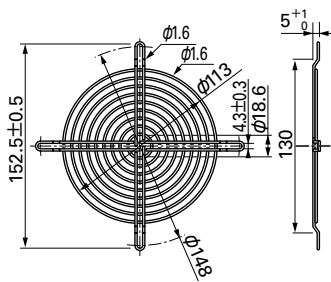

Resin filter kits

Model : 109-1000F13 (13PPI), 109-1000F20 (20PPI) : 109-1000F30 (30PPI), 109-1000F40 (40PPI)

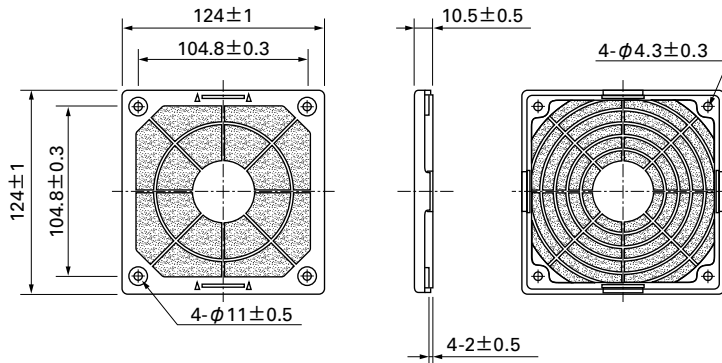

120 mm sq.

San Ace 120

120×120×38mm [Mass : 360g]

Air Flow and Static Pressure Characteristics

PWM Duty Cycle

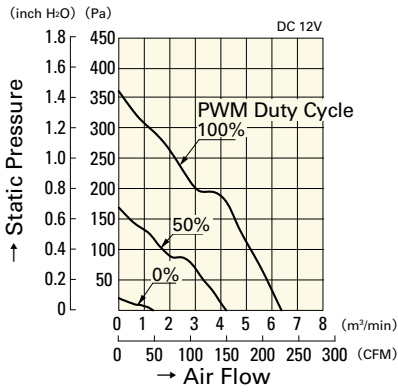

9GV1212P1J01(011)

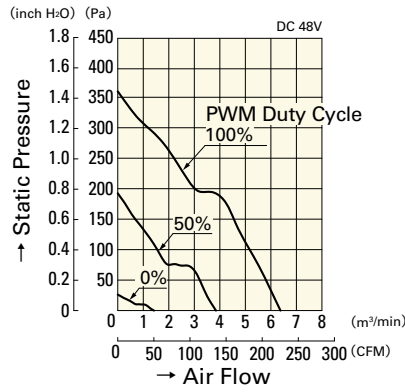

9GV1248P1J01

Operating Voltage Range

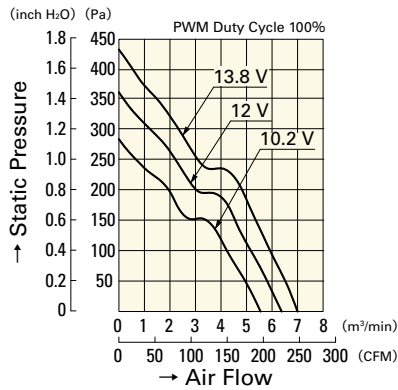

9GV1212P1J01(011)

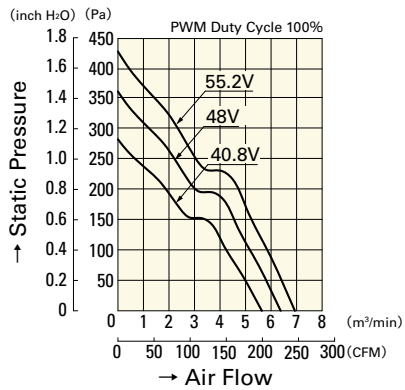

9GV1248P1J01

PWM Duty - Speed Characteristics Example

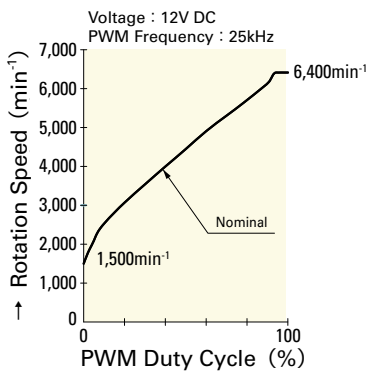

9GV1212P1J01(011)

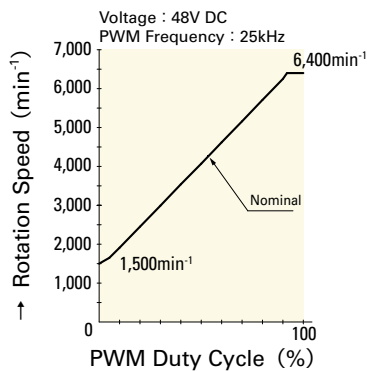

9GV1248P1J01

PWM Input Signal Example

Input Signal Wave Form

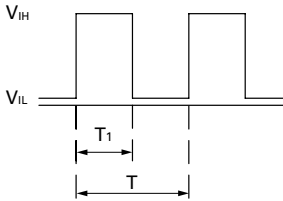

$V_{IH}=4.75V$ to $5.25V$

$V_{IL}=0V$ to $0.4V$

PWM Duty Cycle (%) = $\frac{T_1}{T} \times 100$

PWM Frequency 25 (kHz) = $\frac{1}{T}$

Source Current (I_{source}) : 1mA Max. at control voltage 0V

Sink Current (I_{sink}) : 1mA Max. at control voltage 5.25V

Control Terminal Voltage : 5.25V Max. (Open Circuit)

When the control lead wire is no connecting, the speed is the same speed as at 100% of PWM duty cycle.

This fan speed should be controlled by PWM input signal of either TTL input or open collector, drain input.

Connection Schematic

