

Flare-nut wrenches

▶ Standard series

43 Flanged flare-nut wrenches

- Metric sizes from 7 to 19 mm.
- Flange strengthened 6-point split ring for use on stubborn fittings such as seized pipe unions.
- Short shank for easier handling.
- Chrome finish.

➤	B x B' mm	C mm	D x D' mm	L mm	ΔΔ g
43.7X9	15,6 x 18,3	10	5,0 x 6,6	124	38
43.8X10	16,6 x 19,1	10	5,9 x 7,4	124	40
43.10X11	19,1 x 20	10	7,4 x 8,1	124	43
43.11X13	20 x 22,9	11,5	8,1 x 9,5	143	63
43.12X14	22,3 x 24,6	11,5	8,9 x 10,3	143	66
43.17X19	28,3 x 31,4	13	12,6 x 14,1	162	100

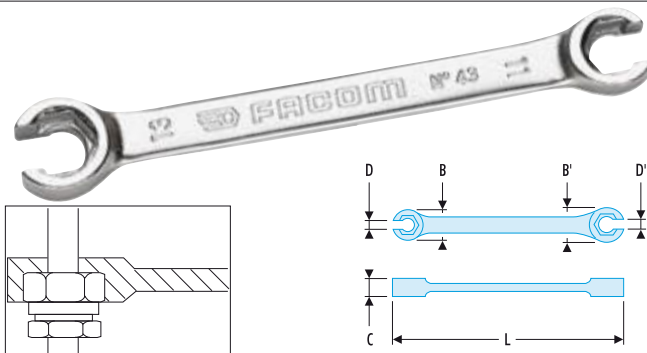

43 Flanged flare-nut wrench sets

- Supplied in a wallet or module

➤	📁	📏	⌀ mm	ΔΔ kg
43.JE5T	N.38A-5B		7x9-8x10-11x13-12x14-17x19	0,330
MOD.43		PL.365	7x9 - 8x10 - 11x13 - 12x14 - 17x19	0,960



42 Metric and inch flare-nut wrenches angled at 15°

▷ DIN 3118.

- Metric sizes from 8 to 41 mm.
- Inch sizes from 5/16" x 3/8" to 1" x 1 1/8".
- 6-point heads up to 12 x 14 mm.
- Chrome finish.

➤	➤	B x B' mm	C mm	D x D' mm	L mm	ΔΔ g
42.8X10	42.5/16x3/8	18 x 20	7 x 8,5	6 x 7	140	55
42.10X11		20 x 22	8,5 x 9	7 x 8,5	150	65
42.10X12		20 x 22	8,5 x 9	7 x 9	150	65
42.11X13	42.7/16x1/2	22 x 26	9 x 10,5	8,5 x 10	165	110
42.12X14		24 x 28	9,5 x 11	9 x 11	170	120
42.14X17	42.9/16x5/8	28 x 30	11 x 12	11 x 14	200	135
42.17X19	42.11/16x3/4	30 x 32	12 x 14	14 x 15	210	175
42.19X22	42.3/4x7/8	32 x 38	14 x 16	15 x 17	220	210
42.22X24		38 x 42	16 x 17	17 x 18	235	270
42.24X27	42.1'x1'1/8	42 x 46	17 x 18	18 x 20	255	290
42.30X32		50 x 52	21 x 23	22 x 24	275	480
42.36X41		60 x 67	25 x 27	25 x 32	310	1100

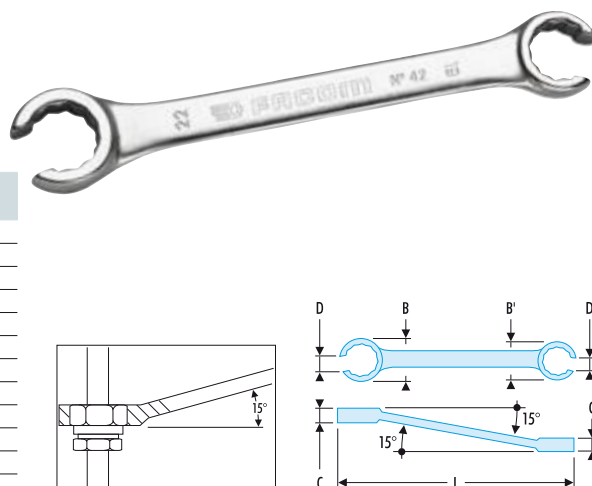

Set of 5 flare-nut wrench angled at 15°

42.JE5T

- Supplied as roll sets.

➤	📁	⌀ mm	ΔΔ g
42.JE5T	N.38A-5A	8x10-11x13-12x14-17x19-22x24	770

