



PIC16F917/916/914/913

Data Sheet

28/40/44-Pin Flash-Based, 8-Bit
CMOS Microcontrollers with
LCD Driver and nanoWatt Technology

Note the following details of the code protection feature on Microchip devices:

- Microchip products meet the specification contained in their particular Microchip Data Sheet.
- Microchip believes that its family of products is one of the most secure families of its kind on the market today, when used in the intended manner and under normal conditions.
- There are dishonest and possibly illegal methods used to breach the code protection feature. All of these methods, to our knowledge, require using the Microchip products in a manner outside the operating specifications contained in Microchip's Data Sheets. Most likely, the person doing so is engaged in theft of intellectual property.
- Microchip is willing to work with the customer who is concerned about the integrity of their code.
- Neither Microchip nor any other semiconductor manufacturer can guarantee the security of their code. Code protection does not mean that we are guaranteeing the product as "unbreakable."

Code protection is constantly evolving. We at Microchip are committed to continuously improving the code protection features of our products. Attempts to break Microchip's code protection feature may be a violation of the Digital Millennium Copyright Act. If such acts allow unauthorized access to your software or other copyrighted work, you may have a right to sue for relief under that Act.

Information contained in this publication regarding device applications and the like is provided only for your convenience and may be superseded by updates. It is your responsibility to ensure that your application meets with your specifications. MICROCHIP MAKES NO REPRESENTATIONS OR WARRANTIES OF ANY KIND WHETHER EXPRESS OR IMPLIED, WRITTEN OR ORAL, STATUTORY OR OTHERWISE, RELATED TO THE INFORMATION, INCLUDING BUT NOT LIMITED TO ITS CONDITION, QUALITY, PERFORMANCE, MERCHANTABILITY OR FITNESS FOR PURPOSE. Microchip disclaims all liability arising from this information and its use. Use of Microchip's products as critical components in life support systems is not authorized except with express written approval by Microchip. No licenses are conveyed, implicitly or otherwise, under any Microchip intellectual property rights.

Trademarks

The Microchip name and logo, the Microchip logo, Accuron, dsPIC, KEELOQ, microID, MPLAB, PIC, PICmicro, PICSTART, PRO MATE, PowerSmart, rfPIC, and SmartShunt are registered trademarks of Microchip Technology Incorporated in the U.S.A. and other countries.

AmpLab, FilterLab, Migratable Memory, MXDEV, MXLAB, PICMASTER, SEEVAL, SmartSensor and The Embedded Control Solutions Company are registered trademarks of Microchip Technology Incorporated in the U.S.A.

Analog-for-the-Digital Age, Application Maestro, dsPICDEM, dsPICDEM.net, dsPICworks, ECAN, ECONOMONITOR, FanSense, FlexROM, fuzzyLAB, In-Circuit Serial Programming, ICSP, ICEPIC, Linear Active Thermistor, MPASM, MPLIB, MPLINK, MPSIM, PICKit, PICDEM, PICDEM.net, PICLAB, PICtail, PowerCal, PowerInfo, PowerMate, PowerTool, rLAB, rfPICDEM, Select Mode, Smart Serial, SmartTel, Total Endurance and WiperLock are trademarks of Microchip Technology Incorporated in the U.S.A. and other countries.

SQTP is a service mark of Microchip Technology Incorporated in the U.S.A.

All other trademarks mentioned herein are property of their respective companies.

© 2005, Microchip Technology Incorporated, Printed in the U.S.A., All Rights Reserved.

 Printed on recycled paper.

QUALITY MANAGEMENT SYSTEM
CERTIFIED BY DNV
== ISO/TS 16949:2002 ==

Microchip received ISO/TS-16949:2002 quality system certification for its worldwide headquarters, design and wafer fabrication facilities in Chandler and Tempe, Arizona and Mountain View, California in October 2003. The Company's quality system processes and procedures are for its PICmicro® 8-bit MCUs, KEELOQ® code hopping devices, Serial EEPROMs, microperipherals, nonvolatile memory and analog products. In addition, Microchip's quality system for the design and manufacture of development systems is ISO 9001:2000 certified.



MICROCHIP PIC16F917/916/914/913

28/40/44-Pin Flash-Based, 8-Bit CMOS Microcontrollers with LCD Driver and nanoWatt Technology

High-Performance RISC CPU:

- Only 35 instructions to learn:
 - All single-cycle instructions except branches
- Operating speed:
 - DC – 20 MHz oscillator/clock input
 - DC – 200 ns instruction cycle
- Program Memory Read (PMR) capability
- Interrupt capability
- 8-level deep hardware stack
- Direct, Indirect and Relative Addressing modes

Special Microcontroller Features:

- Precision Internal Oscillator:
 - Factory calibrated to $\pm 1\%$
 - Software selectable frequency range of 8 MHz to 32 kHz
 - Software tunable
 - Two-Speed Start-up mode
 - Crystal fail detect for critical applications
 - Clock mode switching during operation for power savings
- Power-saving Sleep mode
- Wide operating voltage range (2.0V-5.5V)
- Industrial and Extended temperature range
- Power-on Reset (POR)
- Power-up Timer (PWRT) and Oscillator Start-up Timer (OST)
- Brown-out Reset (BOR) with software control option
- Enhanced Low-Current Watchdog Timer (WDT) with on-chip oscillator (software selectable nominal 268 seconds with full prescaler) with software enable
- Multiplexed Master Clear with pull-up/input pin
- Programmable code protection
- High-Endurance Flash/EEPROM cell:
 - 100,000 write Flash endurance
 - 1,000,000 write EEPROM endurance
 - Flash/Data EEPROM retention: > 40 years

Low-Power Features:

- Standby Current:
 - <100 nA @ 2.0V, typical
- Operating Current:
 - 8.5 μ A @ 32 kHz, 2.0V, typical
 - 100 μ A @ 1 MHz, 2.0V, typical
- Watchdog Timer Current:
 - 1 μ A @ 2.0V, typical

Peripheral Features:

- Liquid Crystal Display module:
 - Up to 60 pixel drive capability on 28-pin devices
 - Up to 96 pixel drive capability on 40-pin devices
 - Four commons
- Up to 35 I/O pins and 1 input-only pin:
 - High-current source/sink for direct LED drive
 - Interrupt-on-pin change
 - Individually programmable weak pull-ups
- In-Circuit Serial Programming™ (ICSP™) via two pins
- Analog comparator module with:
 - Two analog comparators
 - Programmable on-chip voltage reference (CVREF) module (% of V_{DD})
 - Comparator inputs and outputs externally accessible
- A/D Converter:
 - 10-bit resolution and up to 8 channels
- Timer0: 8-bit timer/counter with 8-bit programmable prescaler
- Enhanced Timer1:
 - 16-bit timer/counter with prescaler
 - External Gate Input mode
 - Option to use OSC1 and OSC2 as Timer1 oscillator if INTOSCIO or LP mode is selected
- Timer2: 8-bit timer/counter with 8-bit period register, prescaler and postscaler
- Addressable Universal Synchronous Asynchronous Receiver Transmitter (AUSART)
- Up to 2 Capture, Compare, PWM modules:
 - 16-bit Capture, max. resolution 12.5 ns
 - 16-bit Compare, max. resolution 200 ns
 - 10-bit PWM, max. frequency 20 kHz
- Synchronous Serial Port (SSP) with I²C™

PIC16F917/916/914/913

Device	Program Memory	Data Memory		I/O	10-bit A/D (ch)	LCD (segment drivers)	CCP	Timers 8/16-bit
	Flash (words/bytes)	SRAM (bytes)	EEPROM (bytes)					
PIC16F913	4K/7K	256	256	24	5	16	1	2/1
PIC16F914	4K/7K	256	256	35	8	24	2	2/1
PIC16F916	8K/14K	352	256	24	5	16	1	2/1
PIC16F917	8K/14K	352	256	35	8	24	2	2/1

Pin Diagrams – PIC16F914/917, 40-Pin

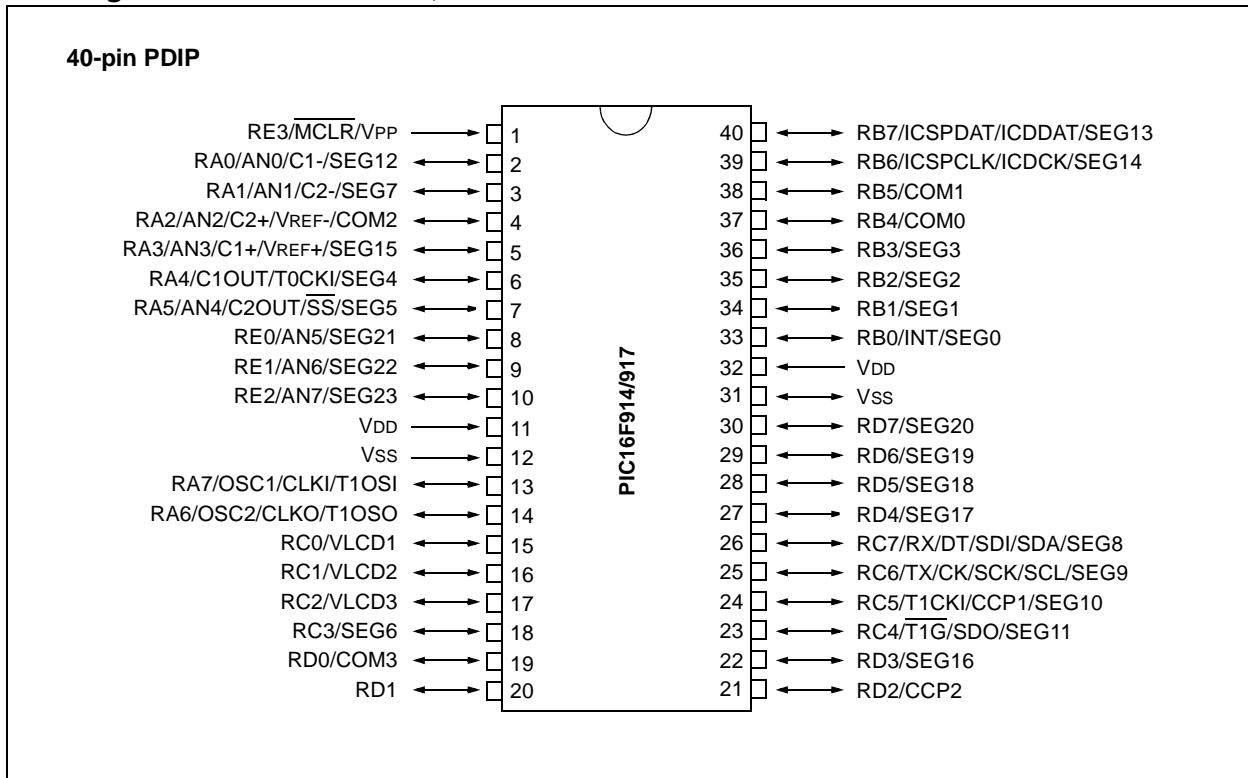

PIC16F917/916/914/913

Pin Diagrams – PIC16F913/916, 28-Pin

28-pin PDIP, SOIC, SSOP

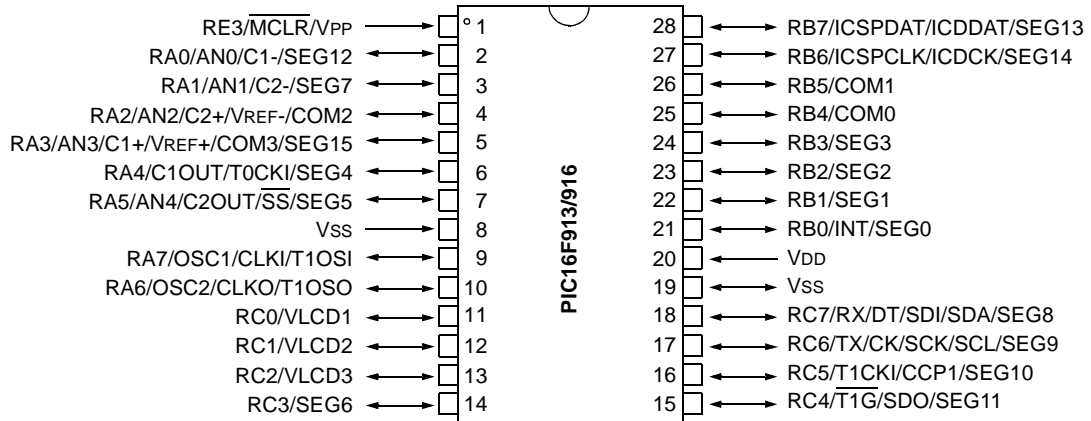

28-pin QFN

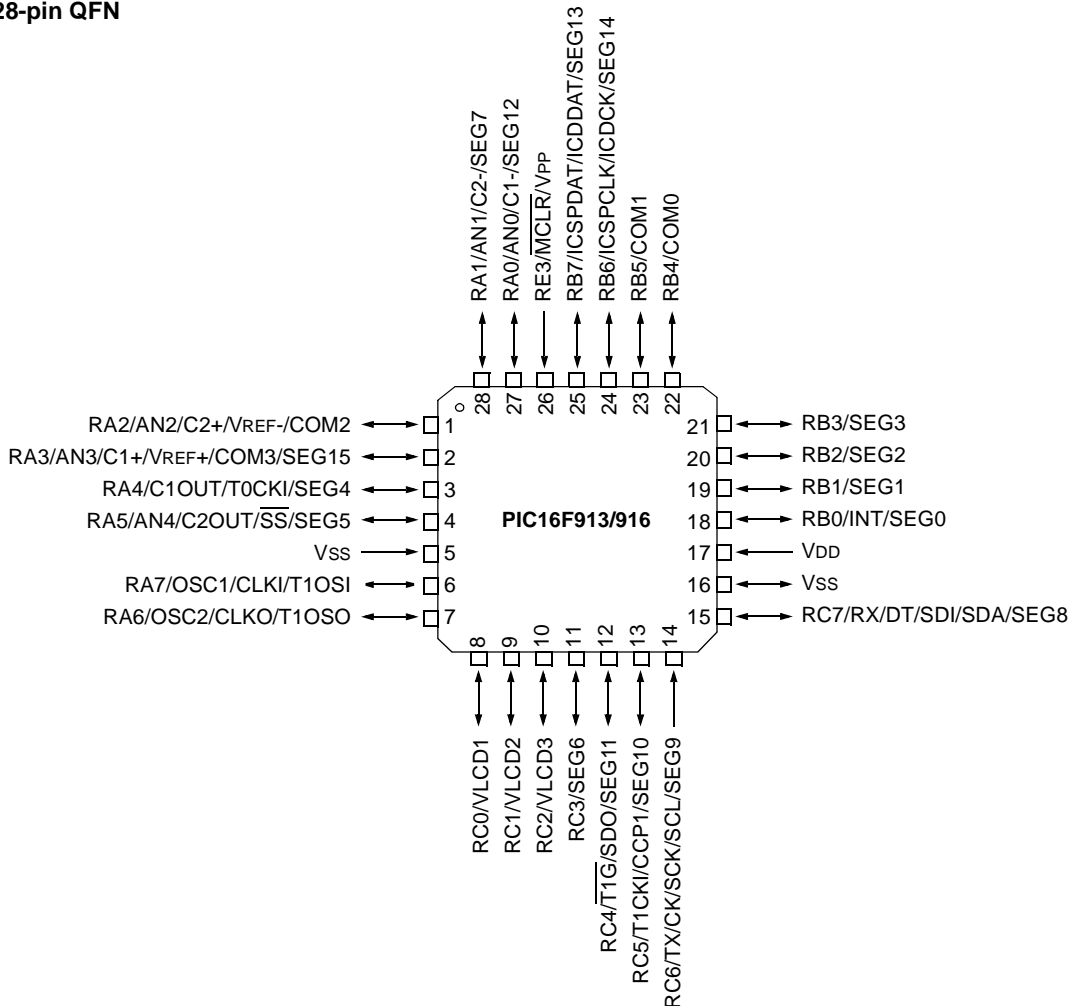

PIC16F917/916/914/913

Pin Diagrams – PIC16F914/917, 44-Pin

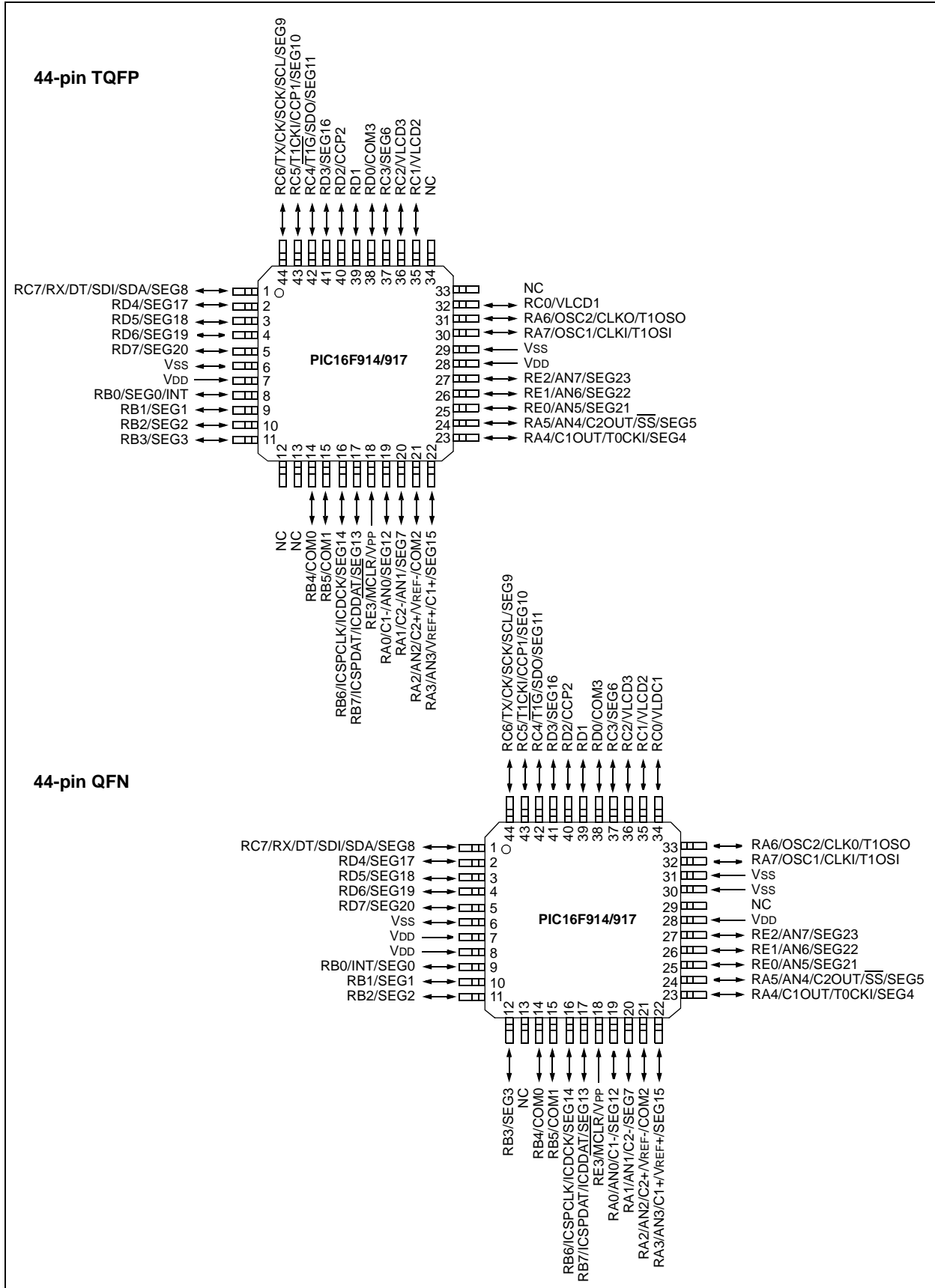

Table of Contents

1.0	Device Overview	7
2.0	Memory Organization	13
3.0	I/O Ports	31
4.0	Clock Sources	69
5.0	Timer0 Module	81
6.0	Timer1 Module With Gate Control	85
7.0	Timer2 Module	90
8.0	Comparator Module.....	93
9.0	Liquid Crystal Display (LCD) Driver Module.....	101
10.0	Programmable Low-Voltage Detect (PLVD) Module.....	125
11.0	Addressable Universal Synchronous Asynchronous Receiver Transmitter (USART).....	127
12.0	Analog-to-Digital Converter (A/D) Module.....	143
13.0	Data EEPROM and Flash Program Memory Control.....	153
14.0	SSP Module Overview	159
15.0	Capture/Compare/PWM Modules	177
16.0	Special Features of the CPU.....	185
17.0	Instruction Set Summary	205
18.0	Development Support.....	215
19.0	Electrical Specifications.....	221
20.0	DC and AC Characteristics Graphs and Tables.....	247
21.0	Packaging Information.....	249
	Appendix A: Data Sheet Revision History.....	259
	Appendix B: Migrating From Other PICmicro® Devices	259
	Appendix C: Conversion Considerations	260
	Index	261
	On-line Support.....	269
	Systems Information and Upgrade Hot Line	269
	Reader Response	270
	Product Identification System	271

TO OUR VALUED CUSTOMERS

It is our intention to provide our valued customers with the best documentation possible to ensure successful use of your Microchip products. To this end, we will continue to improve our publications to better suit your needs. Our publications will be refined and enhanced as new volumes and updates are introduced.

If you have any questions or comments regarding this publication, please contact the Marketing Communications Department via E-mail at docerrors@microchip.com or fax the **Reader Response Form** in the back of this data sheet to (480) 792-4150. We welcome your feedback.

Most Current Data Sheet

To obtain the most up-to-date version of this data sheet, please register at our Worldwide Web site at:

<http://www.microchip.com>

You can determine the version of a data sheet by examining its literature number found on the bottom outside corner of any page. The last character of the literature number is the version number, (e.g., DS30000A is version A of document DS30000).

Errata

An errata sheet, describing minor operational differences from the data sheet and recommended workarounds, may exist for current devices. As device/documentation issues become known to us, we will publish an errata sheet. The errata will specify the revision of silicon and revision of document to which it applies.

To determine if an errata sheet exists for a particular device, please check with one of the following:

- Microchip's Worldwide Web site; <http://www.microchip.com>
- Your local Microchip sales office (see last page)

When contacting a sales office, please specify which device, revision of silicon and data sheet (include literature number) you are using.

Customer Notification System

Register on our web site at www.microchip.com to receive the most current information on all of our products.

PIC16F917/916/914/913

NOTES:

1.0 DEVICE OVERVIEW

This document contains device specific information for the PIC16F91X. Additional information may be found in the “PICmicro® Mid-Range MCU Family Reference Manual” (DS33023), downloaded from the Microchip web site. The Reference Manual should be considered a complementary document to this data sheet and is highly recommended reading for a better understanding of the device architecture and operation of the peripheral modules.

The PIC16F91X devices are covered by this data sheet. It is available in 28/40/44-pin packages.

PIC16F917/916/914/913

FIGURE 1-1: PIC16F913/916 BLOCK DIAGRAM

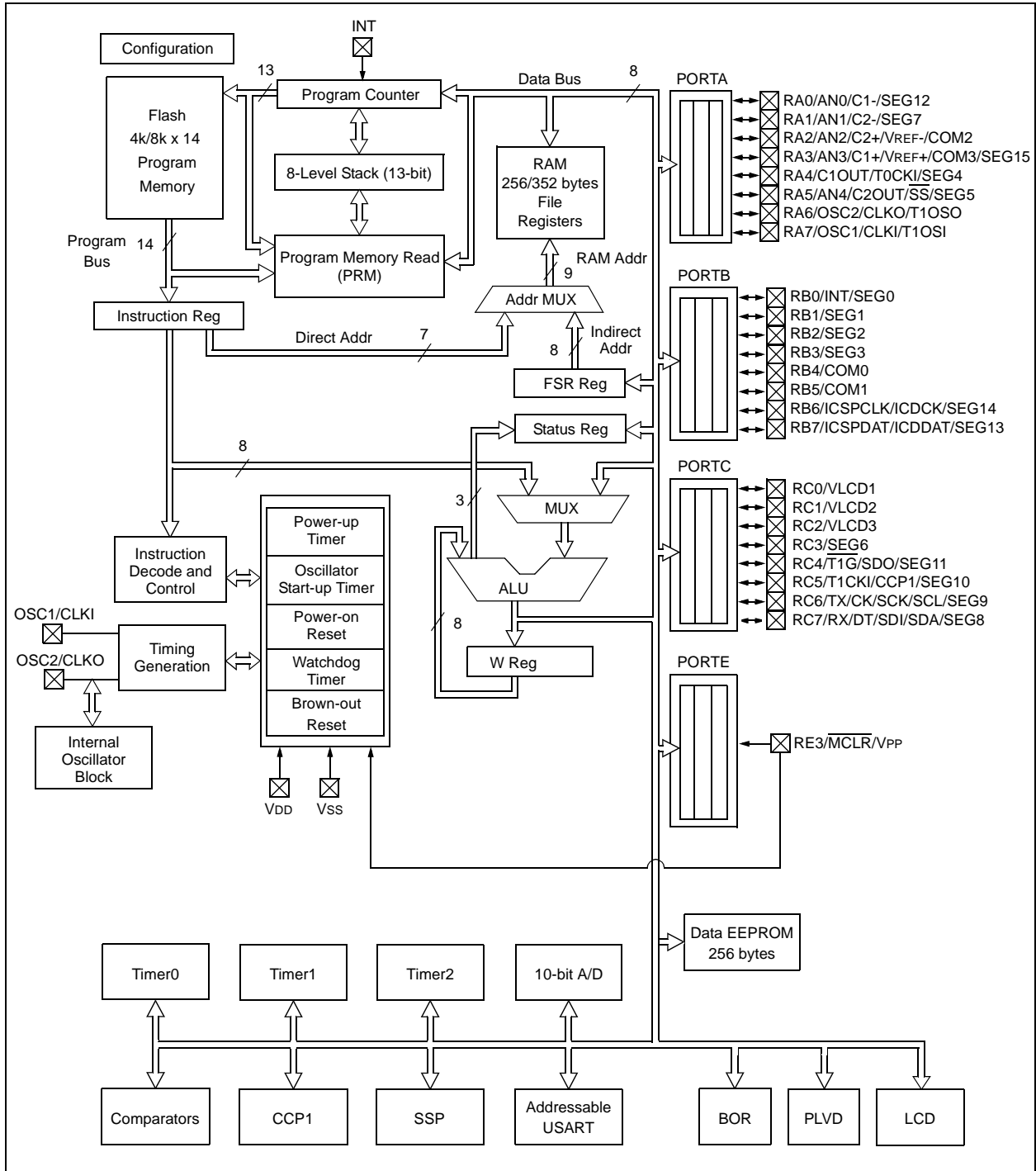

PIC16F917/916/914/913

FIGURE 1-2: PIC16F914/917 BLOCK DIAGRAM

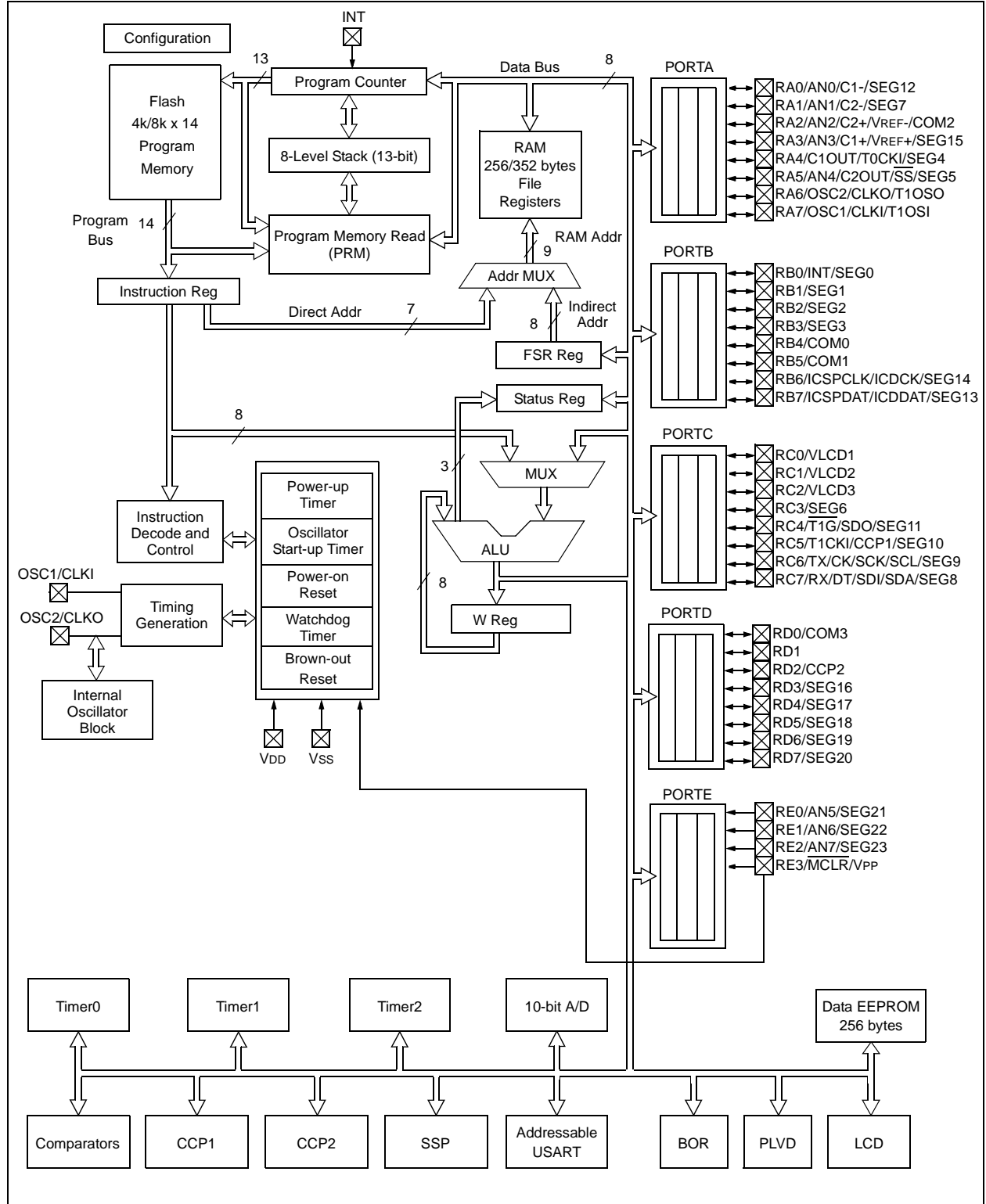

PIC16F917/916/914/913

TABLE 1-1: PIC16F91X PINOUT DESCRIPTIONS

Name	Function	Input Type	Output Type	Description
RA0/AN0/C1-/SEG12	RA0	TTL	CMOS	General purpose I/O.
	AN0	AN	—	Analog input Channel 0/Comparator 1 input – negative.
	C1-	—	AN	Comparator 1 negative input.
	SEG12	—	AN	LCD analog output.
RA1/AN1/C2-/SEG7	RA1	TTL	CMOS	General purpose I/O.
	AN1	AN	—	Analog input Channel 1/Comparator 2 input – negative.
	C2-	—	AN	Comparator 2 negative input.
	SEG7	—	AN	LCD analog output.
RA2/AN2/C2+/VREF-/COM2	RA2	TTL	CMOS	General purpose I/O.
	AN2	AN	—	Analog input Channel 2/Comparator 2 input – positive.
	C2+	—	AN	Comparator 2 positive input.
	VREF-	AN	—	External Voltage Reference – negative.
	COM2	—	AN	LCD analog output.
RA3/AN3/C1+/VREF+/COM3 ⁽¹⁾ /SEG15	RA3	TTL	CMOS	General purpose I/O.
	AN3	AN	—	Analog input Channel 3/Comparator 1 input – positive.
	C1+	—	AN	Comparator 1 positive input.
	VREF+	AN	—	External Voltage Reference – positive.
	COM3 ⁽¹⁾	—	AN	LCD analog output.
	SEG15	—	AN	LCD analog output.
RA4/C1OUT/T0CKI/SEG4	RA4	TTL	CMOS	General purpose I/O.
	C1OUT	—	CMOS	Comparator 1 output.
	T0CKI	ST	—	Timer0 clock input.
	SEG4	—	AN	LCD analog output.
RA5/AN4/C2OUT/ \overline{SS} /SEG5	RA5	TTL	CMOS	General purpose I/O.
	AN4	AN	—	Analog input Channel 4.
	C2OUT	—	CMOS	Comparator 2 output.
	\overline{SS}	TTL	—	Slave select input.
	SEG5	—	AN	LCD analog output.
RA6/OSC2/CLKO/T1OSO	RA6	TTL	CMOS	General purpose I/O.
	OSC2	—	XTAL	Crystal/Resonator.
	CLKO	—	CMOS	Tosc/4 reference clock.
	T1OSO	—	XTAL	Timer1 oscillator output.
RA7/OSC1/CLKI/T1OSI	RA7	TTL	CMOS	General purpose I/O.
	OSC1	XTAL	—	Crystal/Resonator.
	CLKI	ST	—	Clock input.
	T1OSI	XTAL	—	Timer1 oscillator input.
RB0/INT/SEG0	RB0	TTL	CMOS	General purpose I/O. Individually enabled pull-up.
	INT	ST	—	External interrupt pin.
	SEG0	—	AN	LCD analog output.
RB1/SEG1	RB1	TTL	CMOS	General purpose I/O. Individually enabled pull-up.
	SEG1	—	AN	LCD analog output.

Legend: AN = Analog input or output CMOS = CMOS compatible input or output D = Direct
TTL = TTL compatible input ST = Schmitt Trigger input with CMOS levels
HV = High Voltage XTAL = Crystal

Note 1: COM3 is available on RA3 for the PIC16F913/916 and on RD0 for the PIC16F914/917.
2: Pins available on PIC16F914/917 only.

PIC16F917/916/914/913

TABLE 1-1: PIC16F91X PINOUT DESCRIPTIONS (CONTINUED)

Name	Function	Input Type	Output Type	Description
RB2/SEG2	RB2	TTL	CMOS	General purpose I/O. Individually enabled pull-up.
	SEG2	—	AN	LCD analog output.
RB3/SEG3	RB3	TTL	CMOS	General purpose I/O. Individually enabled pull-up.
	SEG3	—	AN	LCD analog output.
RB4/COM0	RB4	TTL	CMOS	General purpose I/O. Individually controlled interrupt-on-change. Individually enabled pull-up.
	COM0	—	AN	LCD analog output.
RB5/COM1	RB5	TTL	CMOS	General purpose I/O. Individually controlled interrupt-on-change. Individually enabled pull-up.
	COM1	—	AN	LCD analog output.
RB6/ICSPCLK/ICDCK/SEG14	RB6	TTL	CMOS	General purpose I/O. Individually controlled interrupt-on-change. Individually enabled pull-up.
	ICSPCLK	ST	—	ICSP™ clock.
	ICDCK	ST	—	ICD clock I/O.
	SEG14	—	AN	LCD analog output.
RB7/ICSPDAT/ICDDAT/SEG13	RB7	TTL	CMOS	General purpose I/O. Individually controlled interrupt-on-change. Individually enabled pull-up.
	ICSPDAT	ST	CMOS	ICSP Data I/O.
	ICDDAT	ST	CMOS	ICD Data I/O.
	SEG13	—	AN	LCD analog output.
RC0/VLCD1	RC0	ST	CMOS	General purpose I/O.
	VLCD1	AN	—	LCD analog input.
RC1/VLCD2	RC1	ST	CMOS	General purpose I/O.
	VLCD2	AN	—	LCD analog input.
RC2/VLCD3	RC2	ST	CMOS	General purpose I/O.
	VLCD3	AN	—	LCD analog input.
RC3/SEG6	RC3	ST	CMOS	General purpose I/O.
	SEG6	—	AN	LCD analog output.
RC4/T1G/SDO/SEG11	RC4	ST	CMOS	General purpose I/O.
	T1G	ST	—	Timer1 gate input.
	SDO	—	CMOS	Serial data output.
	SEG11	—	AN	LCD analog output.
RC5/T1CKI/CCP1/SEG10	RC5	ST	CMOS	General purpose I/O.
	T1CKI	ST	—	Timer1 clock input.
	CCP1	ST	CMOS	Capture 1 input/Compare 1 output/PWM 1 output.
	SEG10	—	AN	LCD analog output.
RC6/TX/CK/SCK/SCL/SEG9	RC6	ST	CMOS	General purpose I/O.
	TX	—	CMOS	USART asynchronous serial transmit.
	CK	ST	CMOS	USART synchronous serial clock.
	SCK	ST	CMOS	SPI™ clock.
	SCL	ST	CMOS	I ² C™ clock.
	SEG9	—	AN	LCD analog output.

Legend: AN = Analog input or output CMOS = CMOS compatible input or output D = Direct
TTL = TTL compatible input ST = Schmitt Trigger input with CMOS levels
HV = High Voltage XTAL = Crystal

Note 1: COM3 is available on RA3 for the PIC16F913/916 and on RD0 for the PIC16F914/917.
2: Pins available on PIC16F914/917 only.

PIC16F917/916/914/913

TABLE 1-1: PIC16F91X PINOUT DESCRIPTIONS (CONTINUED)

Name	Function	Input Type	Output Type	Description
RC7/RX/DT/SDI/SDA/SEG8	RC7	ST	CMOS	General purpose I/O.
	RX	ST	—	USART asynchronous serial receive.
	DT	ST	CMOS	USART synchronous serial data.
	SDI	ST	CMOS	SPI™ data input.
	SDA	ST	CMOS	I ² C™ data.
	SEG8	—	AN	LCD analog output.
RD0/COM3 ^(1, 2)	RD0	ST	CMOS	General purpose I/O.
	COM3	—	AN	LCD analog output.
RD1 ⁽²⁾	RD1	ST	CMOS	General purpose I/O.
RD2/CCP2 ⁽²⁾	RD2	ST	CMOS	General purpose I/O.
	CCP2	ST	CMOS	Capture 2 input/Compare 2 output/PWM 2 output.
RD3/SEG16 ⁽²⁾	RD3	ST	CMOS	General purpose I/O.
	SEG16	—	AN	LCD analog output.
RD4/SEG17 ⁽²⁾	RD4	ST	CMOS	General purpose I/O.
	SEG17	—	AN	LCD analog output.
RD5/SEG18 ⁽²⁾	RD5	ST	CMOS	General purpose I/O.
	SEG18	—	AN	LCD analog output.
RD6/SEG19 ⁽²⁾	RD6	ST	CMOS	General purpose I/O.
	SEG19	—	AN	LCD analog output.
RD7/SEG20 ⁽²⁾	RD7	ST	CMOS	General purpose I/O.
	SEG20	—	AN	LCD analog output.
RE0/AN5/SEG21 ⁽²⁾	RE0	ST	CMOS	General purpose I/O.
	AN5	AN	—	Analog input Channel 5.
	SEG21	—	AN	LCD analog output.
RE1/AN6/SEG22 ⁽²⁾	RE1	ST	CMOS	General purpose I/O.
	AN6	AN	—	Analog input Channel 6.
	SEG22	—	AN	LCD analog output.
RE2/AN7/SEG23 ⁽²⁾	RE2	ST	CMOS	General purpose I/O.
	AN7	AN	—	Analog input Channel 7.
	SEG23	—	AN	LCD analog output.
RE3/MCLR/VPP	RE3	ST	—	Digital input only.
	MCLR	ST	—	Master Clear with internal pull-up.
	VPP	HV	—	Programming voltage.
VDD	VDD	D	—	Power supply for microcontroller.
VSS	VSS	D	—	Ground reference for microcontroller.

Legend: AN = Analog input or output CMOS = CMOS compatible input or output D = Direct
TTL = TTL compatible input ST = Schmitt Trigger input with CMOS levels
HV = High Voltage XTAL = Crystal

Note 1: COM3 is available on RA3 for the PIC16F913/916 and on RD0 for the PIC16F914/917.

2: Pins available on PIC16F914/917 only.

2.0 MEMORY ORGANIZATION

2.1 Program Memory Organization

The PIC16F917/916/914/913 has a 13-bit program counter capable of addressing a 4k x 14 program memory space for the PIC16F913/914 (0000h-0FFFh) and an 8k x 14 program memory space for the PIC16F916/917 (0000h-1FFFh). Accessing a location above the memory boundaries for the PIC16F913 and PIC16F914 will cause a wrap around within the first 4k x 14 space. The Reset vector is at 0000h and the interrupt vector is at 0004h.

FIGURE 2-1: PROGRAM MEMORY MAP AND STACK FOR THE PIC16F913/914

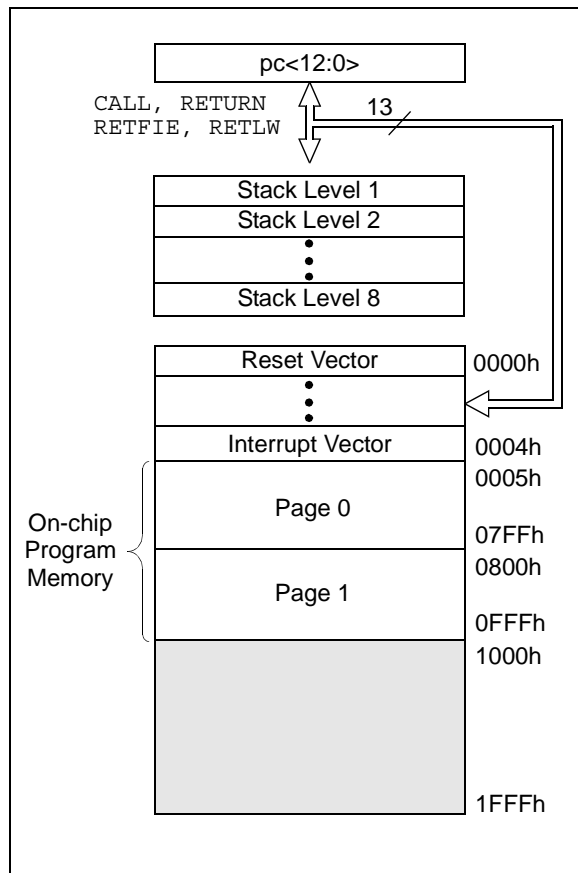
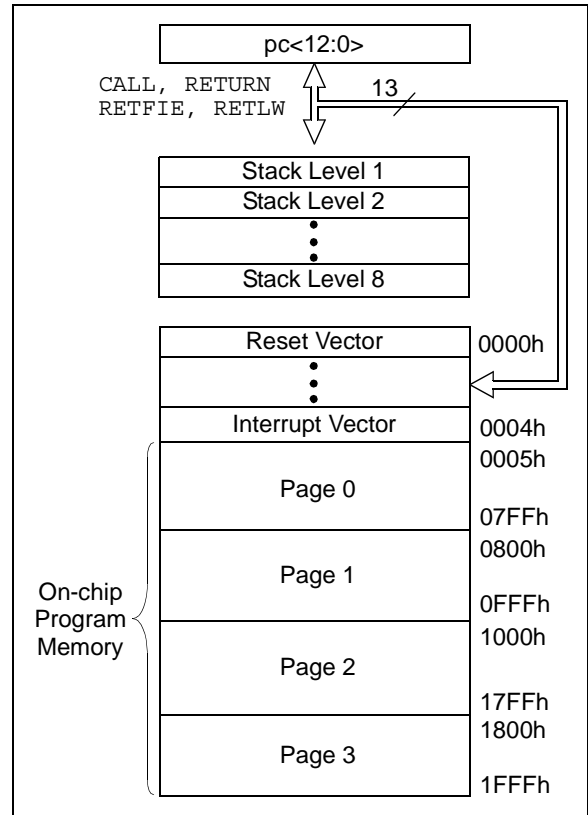

FIGURE 2-2: PROGRAM MEMORY MAP AND STACK FOR THE PIC16F916/917



PIC16F917/916/914/913

2.2 Data Memory Organization

The data memory is partitioned into multiple banks which contain the General Purpose Registers (GPRs) and the Special Function Registers (SFRs). Bits RP0 and RP1 are bank select bits.

RP0	RP1	(STATUS<6:5>)
-----	-----	---------------

- = 00: → Bank 0
- = 01: → Bank 1
- = 10: → Bank 2
- = 11: → Bank 3

Each bank extends up to 7Fh (128 bytes). The lower locations of each bank are reserved for the Special Function Registers. Above the Special Function Registers are the General Purpose Registers, implemented as static RAM. All implemented banks contain Special Function Registers. Some frequently used Special Function Registers from one bank are mirrored in another bank for code reduction and quicker access.

2.2.1 GENERAL PURPOSE REGISTER FILE

The register file is organized as 256 x 8 in the PIC16F913/914 and 352 x 8 in the PIC16F916/917. Each register is accessed either directly or indirectly through the File Select Register (FSR) (see **Section 2.5 “Indirect Addressing, INDF and FSR Registers”**).

2.2.2 SPECIAL FUNCTION REGISTERS

The Special Function Registers are registers used by the CPU and peripheral functions for controlling the desired operation of the device (see Tables 2-1, 2-2, 2-3 and 2-4). These registers are static RAM.

The special registers can be classified into two sets: core and peripheral. The Special Function Registers associated with the “core” are described in this section. Those related to the operation of the peripheral features are described in the section of that peripheral feature.

PIC16F917/916/914/913

FIGURE 2-4: PIC16F914/917 SPECIAL FUNCTION REGISTERS

File Address	File Address	File Address	File Address
Indirect addr. ⁽¹⁾ 00h	Indirect addr. ⁽¹⁾ 80h	Indirect addr. ⁽¹⁾ 100h	Indirect addr. ⁽¹⁾ 180h
TMR0 01h	OPTION_REG 81h	TMR0 101h	OPTION_REG 181h
PCL 02h	PCL 82h	PCL 102h	PCL 182h
STATUS 03h	STATUS 83h	STATUS 103h	STATUS 183h
FSR 04h	FSR 84h	FSR 104h	FSR 184h
PORTA 05h	TRISA 85h	WDTCON 105h	185h
PORTB 06h	TRISB 86h	PORTB 106h	TRISB 186h
PORTC 07h	TRISC 87h	LCDDCON 107h	187h
PORTD 08h	TRISD 88h	LCDPS 108h	188h
PORTE 09h	TRISE 89h	LVDCON 109h	189h
PCLATH 0Ah	PCLATH 8Ah	PCLATH 10Ah	PCLATH 18Ah
INTCON 0Bh	INTCON 8Bh	INTCON 10Bh	INTCON 18Bh
PIR1 0Ch	PIE1 8Ch	EEDATL 10Ch	EECON1 18Ch
PIR2 0Dh	PIE2 8Dh	EEADRL 10Dh	EECON2 ⁽¹⁾ 18Dh
TMR1L 0Eh	PCON 8Eh	EEDATH 10Eh	18Eh
TMR1H 0Fh	OSCCON 8Fh	EEADRH 10Fh	18Fh
T1CON 10h	OSCTUNE 90h	LCDDATA0 110h	190h
TMR2 11h	ANSEL 91h	LCDDATA1 111h	
T2CON 12h	PR2 92h	LCDDATA2 112h	
SSPBUF 13h	SSPADD 93h	LCDDATA3 113h	
SSPCON 14h	SSPSTAT 94h	LCDDATA4 114h	
CCPR2L 15h	WPUB 95h	LCDDATA5 115h	
CCPR2H 16h	IOCB 96h	LCDDATA6 116h	
CCP2CON 17h	CMCON1 97h	LCDDATA7 117h	
RCSTA 18h	TXSTA 98h	LCDDATA8 118h	
TXREG 19h	SPBRG 99h	LCDDATA9 119h	
RCREG 1Ah	9Ah	LCDDATA10 11Ah	
CCPR2L 1Bh	9Bh	LCDDATA11 11Bh	
CCPR2H 1Ch	CMCON0 9Ch	LCDSE0 11Ch	
CCPR2CON 1Dh	VRCON 9Dh	LCDSE1 11Dh	
ADRESH 1Eh	ADRESL 9Eh	LCDSE2 11Eh	
ADCON0 1Fh	ADCON1 9Fh	11Fh	
20h	A0h	120h	
General Purpose Register 96 Bytes	General Purpose Register 80 Bytes	General Purpose Register 80 Bytes	General Purpose Register ⁽²⁾ 96 Bytes
7Fh	accesses 70h-7Fh EFh F0h FFh	accesses 70h-7Fh 16Fh 170h 17Fh	accesses 70h-7Fh 1EFh 1F0h 1FFh
Bank 0	Bank 1	Bank 2	Bank 3

Unimplemented data memory locations, read as '0'.
Note 1: Not a physical register.
2: On the PIC16F914, unimplemented data memory locations, read as '0'.

PIC16F917/916/914/913

TABLE 2-1: PIC16F917/916/914/913 SPECIAL REGISTERS SUMMARY BANK 0

Addr	Name	Bit 7	Bit 6	Bit 5	Bit 4	Bit 3	Bit 2	Bit 1	Bit 0	Value on POR/BOR Reset	Value on all other Resets ⁽¹⁾
Bank 0											
00h	INDF	Addressing this location uses contents of FSR to address data memory (not a physical register)								xxxx xxxx	xxxx xxxx
01h	TMR0	Timer0 Module Register								xxxx xxxx	uuuu uuuu
02h	PCL	Program Counter's (PC) Least Significant Byte								0000 0000	0000 0000
03h	STATUS	IRP	RP1	RP0	\overline{TO}	\overline{PD}	Z	DC	C	0001 1xxx	000q quuu
04h	FSR	Indirect Data Memory Address Pointer								xxxx xxxx	uuuu uuuu
05h	PORTA	RA7	RA6	RA5	RA4	RA3	RA2	RA1	RA0	xxxx xxxx	uuuu uuuu
06h	PORTB	RB7	RB6	RB5	RB4	RB3	RB2	RB1	RB0	xxxx xxxx	uuuu uuuu
07h	PORTC	RC7	RC6	RC5	RC4	RC3	RC2	RC1	RC0	xxxx xxxx	uuuu uuuu
08h	PORTD ⁽²⁾	RD7	RD6	RD5	RD4	RD3	RD2	RD1	RD0	xxxx xxxx	uuuu uuuu
09h	PORTE	—	—	—	—	RE3	RE2 ⁽²⁾	RE1 ⁽²⁾	RE0 ⁽²⁾	---- xxxx	---- uuuu
0Ah	PCLATH	—	—	—	Write Buffer for upper 5 bits of Program Counter					---0 0000	---0 0000
0Bh	INTCON	GIE	PEIE	T0IE	INTE	RBIE	T0IF	INTF	RBIF	0000 000x	0000 000x
0Ch	PIR1	EEIF	ADIF	RCIF	TXIF	SSPIF	CCP1IF	TMR2IF	TMR1IF	0000 0000	0000 0000
0Dh	PIR2	OSFIF	C2IF	C1IF	LCDIF	—	LVDIF	—	CCP2IF	0000 -0-0	0000 -0-0
0Eh	TMR1L	Holding Register for the Least Significant Byte of the 16-bit TMR1								xxxx xxxx	uuuu uuuu
0Fh	TMR1H	Holding Register for the Most Significant Byte of the 16-bit TMR1								xxxx xxxx	uuuu uuuu
10h	T1CON	T1GINV	T1GE	T1CKPS1	T1CKPS0	T1OSCEN	$\overline{T1SYNC}$	TMR1CS	TMR1ON	0000 0000	uuuu uuuu
11h	TMR2	Timer2 Module Register								0000 0000	0000 0000
12h	T2CON	—	TOUTPS3	TOUTPS2	TOUTPS1	TOUTPS0	TMR2ON	T2CKPS1	T2CKPS0	-000 0000	-000 0000
13h	SSPBUF	Synchronous Serial Port Receive Buffer/Transmit Register								xxxx xxxx	uuuu uuuu
14h	SSPCON	WCOL	SSPOV	SSPEN	CKP	SSPM3	SSPM2	SSPM1	SSPM0	0000 0000	0000 0000
15h	CCPR1L	Capture/Compare/PWM Register 1 (LSB)								xxxx xxxx	uuuu uuuu
16h	CCPR1H	Capture/Compare/PWM Register 1 (MSB)								xxxx xxxx	uuuu uuuu
17h	CCP1CON	—	—	CCP1X	CCP1Y	CCP1M3	CCP1M2	CCP1M1	CCP1M0	--00 0000	--00 0000
18h	RCSTA	SPEN	RX9	SREN	CREN	ADDEN	FERR	OERR	RX9D	0000 000x	0000 000x
19h	TXREG	USART Transmit Data Register								0000 0000	0000 0000
1Ah	RCREG	USART Receive Data Register								0000 0000	0000 0000
1Bh ⁽²⁾	CCPR2L	Capture/Compare/PWM Register 2 (LSB)								xxxx xxxx	uuuu uuuu
1Ch ⁽²⁾	CCPR2H	Capture/Compare/PWM Register 2 (MSB)								xxxx xxxx	uuuu uuuu
1Dh ⁽²⁾	CCP2CON	—	—	CCP2X	CCP2Y	CCP2M3	CCP2M2	CCP2M1	CCP2M0	--00 0000	--00 0000
1Eh	ADRESH	A/D Result Register High Byte								xxxx xxxx	uuuu uuuu
1Fh	ADCON0	ADFM	VCFG1	VCFG0	CHS2	CHS1	CHS0	$\overline{GO/DONE}$	ADON	0000 0000	0000 0000

Legend: — = Unimplemented locations read as '0', u = unchanged, x = unknown, q = value depends on condition, shaded = unimplemented

Note 1: Other (non Power-up) Resets include MCLR Reset and Watchdog Timer Reset during normal operation.
Note 2: PIC16F914/917 only.

PIC16F917/916/914/913

TABLE 2-2: PIC16F917/916/914/913 SPECIAL FUNCTION REGISTERS SUMMARY BANK 1

Addr	Name	Bit 7	Bit 6	Bit 5	Bit 4	Bit 3	Bit 2	Bit 1	Bit 0	Value on POR/BOR Reset	Value on all other Resets ⁽¹⁾
Bank 1											
80h	INDF	Addressing this location uses contents of FSR to address data memory (not a physical register)								xxxx xxxx	xxxx xxxx
81h	OPTION_REG	RBPV	INTEDG	T0CS	T0SE	PSA	PS2	PS1	PS0	1111 1111	1111 1111
82h	PCL	Program Counter's (PC) Least Significant Byte								0000 0000	0000 0000
83h	STATUS	IRP	RP1	RP0	\overline{TO}	\overline{PD}	Z	DC	C	0001 1xxx	000q quuu
84h	FSR	Indirect Data Memory Address Pointer								xxxx xxxx	uuuu uuuu
85h	TRISA	TRISA7	TRISA6	TRISA5	TRISA4	TRISA3	TRISA2	TRISA1	TRISA0	1111 1111	1111 1111
86h	TRISB	TRISB7	TRISB6	TRISB5	TRISB4	TRISB3	TRISB2	TRISB1	TRISB0	1111 1111	1111 1111
87h	TRISC	TRISC7	TRISC6	TRISC5	TRISC4	TRISC3	TRISC2	TRISC1	TRISC0	1111 1111	1111 1111
88h	TRISD ⁽²⁾	TRISD7	TRISD6	TRISD5	TRISD4	TRISD3	TRISD2	TRISD1	TRISD0	1111 1111	1111 1111
89h	TRISE	—	—	—	—	TRISE3 ⁽⁵⁾	TRISE2 ⁽²⁾	TRISE1 ⁽²⁾	TRISE0 ⁽²⁾	---- 1111	---- 1111
8Ah	PCLATH	—	—	—	Write Buffer for the upper 5 bits of the Program Counter					---0 0000	---0 0000
8Bh	INTCON	GIE	PEIE	T0IE	INTE	RBIE	T0IF	INTF	RBIF	0000 000x	0000 000x
8Ch	PIE1	EEIE	ADIE	RCIE	TXIE	SSPIE	CCP1IE	TMR2IE	TMR1IE	0000 0000	0000 0000
8Dh	PIE2	OSFIE	C2IE	C1IE	LCDIE	—	LVDIE	—	CCP2IE	0000 -0-0	0000 -0-0
8Eh	PCON	—	—	—	SBOREN	—	—	\overline{POR}	BOR	---1 --qq	---u --uu
8Fh	OSCCON	—	IRCF2	IRCF1	IRCF0	OSTS ⁽⁴⁾	HTS	LTS	SCS	-110 q000	-110 x000
90h	OSCTUNE	—	—	—	TUN4	TUN3	TUN2	TUN1	TUN0	---0 0000	---u uuuu
91h	ANSEL	ANS7 ⁽³⁾	ANS6 ⁽³⁾	ANS5 ⁽³⁾	ANS4	ANS3	ANS2	ANS1	ANS0	1111 1111	1111 1111
92h	PR2	Timer2 Period Register								1111 1111	1111 1111
93h	SSPADD	Synchronous Serial Port (I ² C mode) Address Register								0000 0000	0000 0000
94h	SSPSTAT	SMP	CKE	D/\overline{A}	P	S	R/\overline{W}	UA	BF	0000 0000	0000 0000
95h	WPUB	WPUB7	WPUB6	WPUB5	WPUB4	WPUB3	WPUB2	WPUB1	WPUB0	1111 1111	1111 1111
96h	IOCB	IOCB7	IOCB6	IOCB5	IOCB4	—	—	—	—	0000 ----	0000 ----
97h	CMCON1	—	—	—	—	—	—	T1GSS	C2SYNC	---- --10	---- --10
98h	TXSTA	CSRC	TX9	TXEN	SYNC	—	BRGH	TRMT	TX9D	0000 -010	0000 -010
99h	SPBRG	SPBRG7	SPBRG6	SPBRG5	SPBRG4	SPBRG3	SPBRG2	SPBRG1	SPBRG0	0000 0000	0000 0000
9Ah	—	Unimplemented								—	—
9Bh	—	Unimplemented								—	—
9Ch	CMCON0	C2OUT	C1OUT	C2INV	C1INV	CIS	CM2	CM1	CM0	0000 0000	0000 0000
9Dh	VRCON	VREN	—	VRR	—	VR3	VR2	VR1	VR0	0-0- 0000	0-0- 0000
9Eh	ADRESL	A/D Result Register Low Byte								xxxx xxxx	uuuu uuuu
9Fh	ADCON1	—	ADCS2	ADCS1	ADCS0	—	—	—	—	-000 ----	-000 ---

Legend: - = Unimplemented locations read as '0', u = unchanged, x = unknown, q = value depends on condition, shaded = unimplemented

Note 1: Other (non Power-up) Resets include MCLR Reset and Watchdog Timer Reset during normal operation.

Note 2: PIC16F914/917 only.

Note 3: PIC16F914/917 only, forced '0' on PIC16F913/916.

Note 4: The value of the OSTS bit is dependent on the value of the Configuration Word (CONFIG) of the device. See **Section 4.0 "Clock Sources"**.

Note 5: Bit is read-only; TRISE = 1 always.

PIC16F917/916/914/913

TABLE 2-3: PIC16F917/916/914/913 SPECIAL REGISTERS SUMMARY BANK 2

Addr	Name	Bit 7	Bit 6	Bit 5	Bit 4	Bit 3	Bit 2	Bit 1	Bit 0	Value on POR/BOR Reset	Value on all other Resets ⁽¹⁾		
Bank 2													
100h	INDF	Addressing this location uses contents of FSR to address data memory (not a physical register)								xxxx xxxx	xxxx xxxx		
101h	TMR0	Timer0 Module Register								xxxx xxxx	uuuu uuuu		
102h	PCL	Program Counter's (PC) Least Significant Byte								0000 0000	0000 0000		
103h	STATUS	IRP	RP1	RP0	\overline{TO}	\overline{PD}	Z	DC	C	0001 1xxx	000q quuu		
104h	FSR	Indirect Data Memory Address Pointer								xxxx xxxx	uuuu uuuu		
105h	WDTCON	—	—	—	WDTPS3	WDTPS2	WDTPS1	WDTPS0	SWDTEN	---0 1000	---0 1000		
106h	PORTB	RB7	RB6	RB5	RB4	RB3	RB2	RB1	RB0	xxxx xxxx	uuuu uuuu		
107h	LCDCON	LCDEN	SLPEN	WERR	VLCDEN	CS1	CS0	LMUX1	LMUX0	0001 0011	0001 0011		
108h	LCDPS	WFT	BIASMD	LCDA	WA	LP3	LP2	LP1	LP0	0000 0000	0000 0000		
109h	LVDCON	—	—	IRVST	LVDEN	—	LVDL2	LVDL1	LVDL0	--00 -100	--00 -100		
10Ah	PCLATH	—	—	—	Write Buffer for the upper 5 bits of the Program Counter					---	0000	---	0000
10Bh	INTCON	GIE	PEIE	T0IE	INTE	RBIE	TOIF	INTF	RBIF	0000 000x	0000 000x		
10Ch	EEDATL	EEDATL7	EEDATL6	EEDATL5	EEDATL4	EEDATL3	EEDATL2	EEDATL1	EEDATL0	0000 0000	0000 0000		
10Dh	EEADRL	EEADRL7	EEADRL6	EEADRL5	EEADRL4	EEADRL3	EEADRL2	EEADRL1	EEADRL0	0000 0000	0000 0000		
10Eh	EEDATH	—	—	EEDATH5	EEDATH4	EEDATH3	EEDATH2	EEDATH1	EEDATH0	--00 0000	--00 0000		
10Fh	EEADRH	—	—	—	EEADRH4	EEADRH3	EEADRH2	EEADRH1	EEADRH0	---0 0000	---0 0000		
110h	LCDDATA0	SEG7 COM0	SEG6 COM0	SEG5 COM0	SEG4 COM0	SEG3 COM0	SEG2 COM0	SEG1 COM0	SEG0 COM0	xxxx xxxx	uuuu uuuu		
111h	LCDDATA1	SEG15 COM0	SEG14 COM0	SEG13 COM0	SEG12 COM0	SEG11 COM0	SEG10 COM0	SEG9 COM0	SEG8 COM0	xxxx xxxx	uuuu uuuu		
112h	LCDDATA2 ⁽²⁾	SEG23 COM0	SEG22 COM0	SEG21 COM0	SEG20 COM0	SEG19 COM0	SEG18 COM0	SEG17 COM0	SEG16 COM0	xxxx xxxx	uuuu uuuu		
113h	LCDDATA3	SEG7 COM1	SEG6 COM1	SEG5 COM1	SEG4 COM1	SEG3 COM1	SEG2 COM1	SEG1 COM1	SEG0 COM1	xxxx xxxx	uuuu uuuu		
114h	LCDDATA4	SEG15 COM1	SEG14 COM1	SEG13 COM1	SEG12 COM1	SEG11 COM1	SEG10 COM1	SEG9 COM1	SEG8 COM1	xxxx xxxx	uuuu uuuu		
115h	LCDDATA5 ⁽²⁾	SEG23 COM1	SEG22 COM1	SEG21 COM1	SEG20 COM1	SEG19 COM1	SEG18 COM1	SEG17 COM1	SEG16 COM1	xxxx xxxx	uuuu uuuu		
116h	LCDDATA6	SEG7 COM2	SEG6 COM2	SEG5 COM2	SEG4 COM2	SEG3 COM2	SEG2 COM2	SEG1 COM2	SEG0 COM2	xxxx xxxx	uuuu uuuu		
117h	LCDDATA7	SEG15 COM2	SEG14 COM2	SEG13 COM2	SEG12 COM2	SEG11 COM2	SEG10 COM2	SEG9 COM2	SEG8 COM2	xxxx xxxx	uuuu uuuu		
118h	LCDDATA8 ⁽²⁾	SEG23 COM2	SEG22 COM2	SEG21 COM2	SEG20 COM2	SEG19 COM2	SEG18 COM2	SEG17 COM2	SEG16 COM2	xxxx xxxx	uuuu uuuu		
119h	LCDDATA9	SEG7 COM3	SEG6 COM3	SEG5 COM3	SEG4 COM3	SEG3 COM3	SEG2 COM3	SEG1 COM3	SEG0 COM3	xxxx xxxx	uuuu uuuu		
11Ah	LCDDATA10	SEG15 COM3	SEG14 COM3	SEG13 COM3	SEG12 COM3	SEG11 COM3	SEG10 COM3	SEG9 COM3	SEG8 COM3	xxxx xxxx	uuuu uuuu		
11Bh	LCDDATA11 ⁽²⁾	SEG23 COM3	SEG22 COM3	SEG21 COM3	SEG20 COM3	SEG19 COM3	SEG18 COM3	SEG17 COM3	SEG16 COM3	xxxx xxxx	uuuu uuuu		
11Ch	LCNSE0 ⁽³⁾	SE7	SE6	SE5	SE4	SE3	SE2	SE1	SE0	0000 0000	uuuu uuuu		
11Dh	LCNSE1 ⁽³⁾	SE15	SE14	SE13	SE12	SE11	SE10	SE9	SE8	0000 0000	uuuu uuuu		
11Eh	LCNSE2 ^(2,3)	SE23	SE22	SE21	SE20	SE19	SE18	SE17	SE16	0000 0000	uuuu uuuu		
11Fh	—	Unimplemented								—	—		

Legend: — = Unimplemented locations read as '0', u = unchanged, x = unknown, q = value depends on condition, shaded = unimplemented

- Note**
- 1: Other (non Power-up) Resets include MCLR Reset and Watchdog Timer Reset during normal operation.
 - 2: PIC16F914/917 only.
 - 3: This register is only initialized by a POR or BOR reset and is unchanged by other Resets.

PIC16F917/916/914/913

TABLE 2-4: PIC16F917/916/914/913 SPECIAL FUNCTION REGISTERS SUMMARY BANK 3

Addr	Name	Bit 7	Bit 6	Bit 5	Bit 4	Bit 3	Bit 2	Bit 1	Bit 0	Value on POR/BOR Reset	Value on all other Resets ⁽¹⁾	
Bank 3												
180h	INDF	Addressing this location uses contents of FSR to address data memory (not a physical register)								xxxx xxxx	xxxx xxxx	
181h	OPTION_REG	RBP \bar{U}	INTEDG	T0CS	T0SE	PSA	PS2	PS1	PS0	1111 1111	1111 1111	
182h	PCL	Program Counter (PC) Least Significant Byte								0000 0000	0000 0000	
183h	STATUS	IRP	RP1	RP0	$\bar{T}O$	$\bar{P}D$	Z	DC	C	0001 1xxx	000q quuu	
184h	FSR	Indirect Data Memory Address Pointer								xxxx xxxx	uuuu uuuu	
185h	—	Unimplemented								—	—	
186h	TRISB	TRISB7	TRISB6	TRISB5	TRISB4	TRISB3	TRISB2	TRISB1	TRISB0	1111 1111	1111 1111	
187h	—	Unimplemented								—	—	
188h	—	Unimplemented								—	—	
189h	—	Unimplemented								—	—	
18Ah	PCLATH	—	—	—	Write Buffer for the upper 5 bits of the Program Counter				---	0 0000	---	0 0000
18Bh	INTCON	GIE	PEIE	T0IE	INTE	RBIE	T0IF	INTF	RBIF	0000 000x	0000 000x	
18Ch	EECON1	EEPGD	—	—	—	WRERR	WREN	WR	RD	0--- x000	0--- q000	
18Dh	EECON2	EEPROM Control Register 2 (not a physical register)								----	----	

Legend: - = Unimplemented locations read as '0', u = unchanged, x = unknown, q = value depends on condition, shaded = unimplemented

Note 1: Other (non Power-up) Resets include MCLR Reset and Watchdog Timer Reset during normal operation.

2.2.2.1 Status Register

The Status register, shown in Register 2-1, contains:

- the arithmetic status of the ALU
- the Reset status
- the bank select bits for data memory (SRAM)

The Status register can be the destination for any instruction, like any other register. If the Status register is the destination for an instruction that affects the Z, DC or C bits, then the write to these three bits is disabled. These bits are set or cleared according to the device logic. Furthermore, the $\overline{\text{TO}}$ and $\overline{\text{PD}}$ bits are not writable. Therefore, the result of an instruction with the Status register as destination may be different than intended.

For example, `CLRF STATUS` will clear the upper three bits and set the Z bit. This leaves the Status register as '000u u1uu' (where u = unchanged).

It is recommended, therefore, that only `BCF`, `BSF`, `SWAPF` and `MOVWF` instructions are used to alter the Status register, because these instructions do not affect any Status bits. For other instructions not affecting any Status bits (see **Section 17.0 "Instruction Set Summary"**).

Note 1: The $\overline{\text{C}}$ and $\overline{\text{DC}}$ bits operate as a Borrow and Digit Borrow out bit, respectively, in subtraction. See the `SUBLW` and `SUBWF` instructions for examples.

REGISTER 2-1: STATUS – STATUS REGISTER (ADDRESS: 03h, 83h, 103h OR 183h)

	R/W-0	R/W-0	R/W-0	R-1	R-1	R/W-x	R/W-x	R/W-x
	IRP	RP1	RP0	$\overline{\text{TO}}$	$\overline{\text{PD}}$	Z	DC	C
bit 7								bit 0

- bit 7 **IRP:** Register Bank Select bit (used for indirect addressing)
 1 = Bank 2, 3 (100h-1FFh)
 0 = Bank 0, 1 (00h-FFh)
- bit 6-5 **RP<1:0>:** Register Bank Select bits (used for direct addressing)
 00 = Bank 0 (00h-7Fh)
 01 = Bank 1 (80h-FFh)
 10 = Bank 2 (100h-17Fh)
 11 = Bank 3 (180h-1FFh)
- bit 4 **$\overline{\text{TO}}$:** Time-out bit
 1 = After power-up, `CLRWDT` instruction or `SLEEP` instruction
 0 = A WDT time-out occurred
- bit 3 **$\overline{\text{PD}}$:** Power-down bit
 1 = After power-up or by the `CLRWDT` instruction
 0 = By execution of the `SLEEP` instruction
- bit 2 **Z:** Zero bit
 1 = The result of an arithmetic or logic operation is zero
 0 = The result of an arithmetic or logic operation is not zero
- bit 1 **DC:** Digit Carry/Borrow bit (`ADDWF`, `ADDLW`, `SUBLW`, `SUBWF` instructions)⁽¹⁾
 1 = A carry-out from the 4th low-order bit of the result occurred
 0 = No carry-out from the 4th low-order bit of the result
- bit 0 **C:** Carry/Borrow bit (`ADDWF`, `ADDLW`, `SUBLW`, `SUBWF` instructions)⁽¹⁾
 1 = A carry-out from the Most Significant bit of the result occurred
 0 = No carry-out from the Most Significant bit of the result occurred

Note 1: For Borrow, the polarity is reversed. A subtraction is executed by adding the two's complement of the second operand. For rotate (`RRF`, `RLF`) instructions, this bit is loaded with either the high or low-order bit of the source register.

Legend:

R = Readable bit	W = Writable bit	U = Unimplemented bit, read as '0'
- n = Value at POR	'1' = Bit is set	'0' = Bit is cleared x = Bit is unknown

PIC16F917/916/914/913

2.2.2.2 Option Register

The Option register is a readable and writable register, which contains various control bits to configure:

- TMR0/WDT prescaler
- External RB0/INT interrupt
- TMR0
- Weak pull-ups on PORTB

Note: To achieve a 1:1 prescaler assignment for TMR0, assign the prescaler to the WDT by setting PSA bit to '1' (OPTION_REG<3>). See **Section 5.4 "Prescaler"**.

REGISTER 2-2: OPTION_REG – OPTION REGISTER (ADDRESS: 81h OR 181h)

	R/W-1	R/W-1	R/W-1	R/W-1	R/W-1	R/W-1	R/W-1	R/W-1
	RBP $\overline{\text{U}}$	INTEDG	T0CS	T0SE	PSA	PS2	PS1	PS0
bit 7								bit 0

- bit 7 **RBP $\overline{\text{U}}$** : PORTB Pull-up Enable bit
 1 = PORTB pull-ups are disabled
 0 = PORTB pull-ups are enabled by individual port latch values
- bit 6 **INTEDG**: Interrupt Edge Select bit
 1 = Interrupt on rising edge of RB0/INT/SEG0 pin
 0 = Interrupt on falling edge of RB0/INT/SEG0 pin
- bit 5 **T0CS**: TMR0 Clock Source Select bit
 1 = Transition on RA4/C1OUT/T0CKI/SEG4 pin
 0 = Internal instruction cycle clock (CLKO)
- bit 4 **T0SE**: TMR0 Source Edge Select bit
 1 = Increment on high-to-low transition on RA4/C1OUT/T0CKI/SEG4 pin
 0 = Increment on low-to-high transition on RA4/C1OUT/T0CKI/SEG4 pin
- bit 3 **PSA**: Prescaler Assignment bit
 1 = Prescaler is assigned to the WDT
 0 = Prescaler is assigned to the Timer0 module
- bit 2-0 **PS<2:0>**: Prescaler Rate Select bits

Bit Value	TMR0 Rate	WDT Rate
000	1 : 2	1 : 1
001	1 : 4	1 : 2
010	1 : 8	1 : 4
011	1 : 16	1 : 8
100	1 : 32	1 : 16
101	1 : 64	1 : 32
110	1 : 128	1 : 64
111	1 : 256	1 : 128

Legend:

R = Readable bit W = Writable bit U = Unimplemented bit, read as '0'
 - n = Value at POR '1' = Bit is set '0' = Bit is cleared x = Bit is unknown

PIC16F917/916/914/913

2.2.2.3 INTCON Register

The INTCON register is a readable and writable register, which contains the various enable and flag bits for TMR0 register overflow, PORTB change and external RB0/INT/SEG0 pin interrupts.

Note: Interrupt flag bits are set when an interrupt condition occurs, regardless of the state of its corresponding enable bit or the global enable bit, GIE (INTCON<7>). User software should ensure the appropriate interrupt flag bits are clear prior to enabling an interrupt.

REGISTER 2-3: INTCON – INTERRUPT CONTROL REGISTER (ADDRESS: 0Bh, 8Bh, 10Bh OR 18Bh)

R/W-0	R/W-0	R/W-0	R/W-0	R/W-0	R/W-0	R/W-0	R/W-x
GIE	PEIE	TOIE	INTE	RBIE	TOIF	INTF	RBIF
						bit 7	bit 0

- bit 7 **GIE:** Global Interrupt Enable bit
1 = Enables all unmasked interrupts
0 = Disables all interrupts
 - bit 6 **PEIE:** Peripheral Interrupt Enable bit
1 = Enables all unmasked peripheral interrupts
0 = Disables all peripheral interrupts
 - bit 5 **TOIE:** TMR0 Overflow Interrupt Enable bit
1 = Enables the TMR0 interrupt
0 = Disables the TMR0 interrupt
 - bit 4 **INTE:** RB0/INT/SEG0 External Interrupt Enable bit
1 = Enables the RB0/INT/SEG0 external interrupt
0 = Disables the RB0/INT/SEG0 external interrupt
 - bit 3 **RBIE:** PORTB Change Interrupt Enable bit⁽¹⁾
1 = Enables the PORTB change interrupt
0 = Disables the PORTB change interrupt
 - bit 2 **TOIF:** TMR0 Overflow Interrupt Flag bit⁽²⁾
1 = TMR0 register has overflowed (must be cleared in software)
0 = TMR0 register did not overflow
 - bit 1 **INTF:** RB0/INT/SEG0 External Interrupt Flag bit
1 = The RB0/INT/SEG0 external interrupt occurred (must be cleared in software)
0 = The RB0/INT/SEG0 external interrupt did not occur
 - bit 0 **RBIF:** PORTB Change Interrupt Flag bit
1 = When at least one of the PORTB <5:0> pins changed state (must be cleared in software)
0 = None of the PORTB <7:4> pins have changed state
- Note 1:** IOCB register must also be enabled.
- 2:** TOIF bit is set when Timer0 rolls over. Timer0 is unchanged on Reset and should be initialized before clearing TOIF bit.

Legend:

R = Readable bit W = Writable bit U = Unimplemented bit, read as '0'
 - n = Value at POR '1' = Bit is set '0' = Bit is cleared x = Bit is unknown

PIC16F917/916/914/913

2.2.2.4 PIE1 Register

The PIE1 register contains the interrupt enable bits, as shown in Register 2-1.

Note: Bit PEIE (INTCON<6>) must be set to enable any peripheral interrupt.

REGISTER 2-4: PIE1 – PERIPHERAL INTERRUPT ENABLE REGISTER 1 (ADDRESS: 8Ch)

R/W-0	R/W-0	R/W-0	R/W-0	R/W-0	R/W-0	R/W-0	R/W-0
EEIE	ADIE	RCIE	TXIE	SSPIE	CCP1IE	TMR2IE	TMR1IE
bit 7				bit 0			

- bit 7 **EEIE:** EE Write Complete Interrupt Enable bit
1 = Enabled
0 = Disabled
- bit 6 **ADIE:** A/D Converter Interrupt Enable bit
1 = Enabled
0 = Disabled
- bit 5 **RCIE:** USART Receive Interrupt Enable bit
1 = Enabled
0 = Disabled
- bit 4 **TXIE:** USART Transmit Interrupt Enable bit
1 = Enabled
0 = Disabled
- bit 3 **SSPIE:** Synchronous Serial Port (SSP) Interrupt Enable bit
1 = Enabled
0 = Disabled
- bit 2 **CCP1IE:** CCP1 Interrupt Enable bit
1 = Enabled
0 = Disabled
- bit 1 **TMR2IE:** TMR2 to PR2 Match Interrupt Enable bit
1 = Enabled
0 = Disabled
- bit 0 **TMR1IE:** TMR1 Overflow Interrupt Enable bit
1 = Enabled
0 = Disabled

Legend:

R = Readable bit W = Writable bit U = Unimplemented bit, read as '0'
- n = Value at POR '1' = Bit is set '0' = Bit is cleared x = Bit is unknown

PIC16F917/916/914/913

2.2.2.5 PIE2 Register

The PIE2 register contains the interrupt enable bits, as shown in Register 2-5.

Note: Bit PEIE (INTCON<6>) must be set to enable any peripheral interrupt.

REGISTER 2-5: PIE2 – PERIPHERAL INTERRUPT ENABLE REGISTER 2 (ADDRESS: 8Dh)

R/W-0	R/W-0	R/W-0	R/W-0	U-0	R/W-0	U-0	R/W-0
OSFIE	C2IE	C1IE	LCDIE	—	LVDIE	—	CCP2IE
bit 7				bit 0			

- bit 7 **OSFIE:** Oscillator Fail Interrupt Enable bit
1 = Enabled
0 = Disabled
- bit 6 **C2IE:** Comparator 2 Interrupt Enable bit
1 = Enables Comparator 2 interrupt
0 = Disables Comparator 2 interrupt
- bit 5 **C1IE:** Comparator 1 Interrupt Enable bit
1 = Enables Comparator 1 interrupt
0 = Disables Comparator 1 interrupt
- bit 4 **LCDIE:** LCD Module Interrupt Enable bit
1 = LCD interrupt is enabled
0 = LCD interrupt is disabled
- bit 3 **Unimplemented:** Read as '0'
- bit 2 **LVDIE:** Low Voltage Detect Interrupt Enable bit
1 = Enables LVD Interrupt
0 = Disables LVD Interrupt
- bit 1 **Unimplemented:** Read as '0'
- bit 0 **CCP2IE:** CCP2 Interrupt Enable bit (only available in 16F914/917)
1 = Enables the CCP2 interrupt
0 = Disables the CCP2 interrupt

Legend:

R = Readable bit W = Writable bit U = Unimplemented bit, read as '0'
- n = Value at POR '1' = Bit is set '0' = Bit is cleared x = Bit is unknown

PIC16F917/916/914/913

2.2.2.6 PIR1 Register

The PIR1 register contains the interrupt flag bits, as shown in Register 2-6.

Note: Interrupt flag bits are set when an interrupt condition occurs, regardless of the state of its corresponding enable bit or the global enable bit, GIE (INTCON<7>). User software should ensure the appropriate interrupt flag bits are clear prior to enabling an interrupt.

REGISTER 2-6: PIR1 – PERIPHERAL INTERRUPT REQUEST REGISTER 1 (ADDRESS: 0Ch)

R/W-0	R/W-0	R-0	R-0	R/W-0	R/W-0	R/W-0	R/W-0
EEIF	ADIF	RCIF	TXIF	SSPIF	CCP1IF	TMR2IF	TMR1IF

bit 7

bit 0

- bit 7 **EEIF:** EE Write Operation Interrupt Flag bit
 1 = The write operation completed (must be cleared in software)
 0 = The write operation has not completed or has not started
- bit 6 **ADIF:** A/D Converter Interrupt Flag bit
 1 = The A/D conversion completed (must be cleared in software)
 0 = The A/D conversion is not complete
- bit 5 **RCIF:** USART Receive Interrupt Flag bit
 1 = The USART receive buffer is full (cleared by reading RCREG)
 0 = The USART receive buffer is not full
- bit 4 **TXIF:** USART Transmit Interrupt Flag bit
 1 = The USART transmit buffer is empty (cleared by writing to TXREG)
 0 = The USART transmit buffer is full
- bit 3 **SSPIF:** Synchronous Serial Port (SSP) Interrupt Flag bit
 1 = The Transmission/Reception is complete (must be cleared in software)
 0 = Waiting to Transmit/Receive
- bit 2 **CCP1IF:** CCP1 Interrupt Flag bit
 Capture Mode
 1 = A TMR1 register capture occurred (must be cleared in software)
 0 = No TMR1 register capture occurred
 Compare Mode
 1 = A TMR1 register compare match occurred (must be cleared in software)
 0 = No TMR1 register compare match occurred
 PWM mode
 Unused in this mode
- bit 1 **TMR2IF:** TMR2 to PR2 Interrupt Flag bit
 1 = A TMR2 to PR2 match occurred (must be cleared in software)
 0 = No TMR2 to PR2 match occurred
- bit 0 **TMR1IF:** TMR1 Overflow Interrupt Flag bit
 1 = The TMR1 register overflowed (must be cleared in software)
 0 = The TMR1 register did not overflow

Legend:
 R = Readable bit W = Writable bit U = Unimplemented bit, read as '0'
 - n = Value at POR '1' = Bit is set '0' = Bit is cleared x = Bit is unknown

PIC16F917/916/914/913

2.2.2.7 PIR2 Register

The PIR2 register contains the interrupt flag bits, as shown in Register 2-7.

Note: Interrupt flag bits are set when an interrupt condition occurs, regardless of the state of its corresponding enable bit or the global enable bit, GIE (INTCON<7>). User software should ensure the appropriate interrupt flag bits are clear prior to enabling an interrupt.

REGISTER 2-7: PIR2 – PERIPHERAL INTERRUPT REQUEST REGISTER 2 (ADDRESS: 0Dh)

R/W-0	R/W-0	R-0	R-0	U-0	R/W-0	U-0	R/W-0
OSFIF	C2IF	C1IF	LCDIF	—	LVDIF	—	CCP2IF

bit 7

bit 0

- bit 7 **OSFIF:** Oscillator Fail Interrupt Flag bit
1 = System oscillator failed, clock input has changed to INTOSC (must be cleared in software)
0 = System clock operating
- bit 6 **C2IF:** Comparator 2 Interrupt Flag bit
1 = Comparator output (C2OUT bit) has changed (must be cleared in software)
0 = Comparator output (C2OUT bit) has not changed
- bit 5 **C1IF:** Comparator 1 Interrupt Flag bit
1 = Comparator output (C1OUT bit) has changed (must be cleared in software)
0 = Comparator output (C1OUT bit) has not changed
- bit 4 **LCDIF:** LCD Module Interrupt bit
1 = LCD has generated an interrupt
0 = LCD has not generated an interrupt
- bit 3 **Unimplemented:** Read as '0'
- bit 2 **LVDIF:** Low Voltage Detect Interrupt Flag bit
1 = LVD has generated an interrupt
0 = LVD has not generated an interrupt
- bit 1 **Unimplemented:** Read as '0'
- bit 0 **CCP2IF:** CCP2 Interrupt Flag bit (only available in 16F914/917)
Capture Mode
1 = A TMR1 register capture occurred (must be cleared in software)
0 = No TMR1 register capture occurred
Compare Mode
1 = A TMR1 register compare match occurred (must be cleared in software)
0 = No TMR1 register compare match occurred
PWM mode
Unused in this mode

Legend:

R = Readable bit W = Writable bit U = Unimplemented bit, read as '0'
- n = Value at POR '1' = Bit is set '0' = Bit is cleared x = Bit is unknown

PIC16F917/916/914/913

2.2.2.8 PCON Register

The Power Control (PCON) register (See Table 17-2) contains flag bits to differentiate between a:

- Power-on Reset ($\overline{\text{POR}}$)
- Brown-out Reset ($\overline{\text{BOR}}$)
- Watchdog Timer Reset (WDT)
- External MCLR Reset

The PCON register also controls the software enable of the BOR.

The PCON register bits are shown in Register 2-8.

REGISTER 2-8: PCON – POWER CONTROL REGISTER (ADDRESS: 8Eh)

U-0	U-0	U-0	R/W-1	U-0	U-0	R/W-0	R/W-x
—	—	—	SBOREN	—	—	$\overline{\text{POR}}$	$\overline{\text{BOR}}$
bit 7							bit 0

bit 7-5 **Unimplemented:** Read as '0'

bit 4 **SBOREN:** Software BOR Enable bit⁽¹⁾
 1 = BOR enabled
 0 = BOR disabled

bit 3-2 **Unimplemented:** Read as '0'

bit 1 **POR:** Power-on Reset Status bit
 1 = No Power-on Reset occurred
 0 = A Power-on Reset occurred (must be set in software after a Power-on Reset occurs)

bit 0 **BOR:** Brown-out Reset Status bit
 1 = No Brown-out Reset occurred
 0 = A Brown-out Reset occurred (must be set in software after a Brown-out Reset occurs)

Note 1: BOREN<1:0> = 01 in the Configuration Word register for this bit to control the $\overline{\text{BOR}}$.

Legend:

R = Readable bit	W = Writable bit	U = Unimplemented bit, read as '0'
- n = Value at POR	'1' = Bit is set	'0' = Bit is cleared x = Bit is unknown

2.3 PCL and PCLATH

The Program Counter (PC) is 13 bits wide. The low byte comes from the PCL register, which is a readable and writable register. The high byte (PC<12:8>) is not directly readable or writable and comes from PCLATH. On any Reset, the PC is cleared. Figure 2-5 shows the two situations for the loading of the PC. The upper example in Figure 2-5 shows how the PC is loaded on a write to PCL (PCLATH<4:0> → PCH). The lower example in Figure 2-5 shows how the PC is loaded during a CALL or GOTO instruction (PCLATH<4:3> → PCH).

FIGURE 2-5: LOADING OF PC IN DIFFERENT SITUATIONS

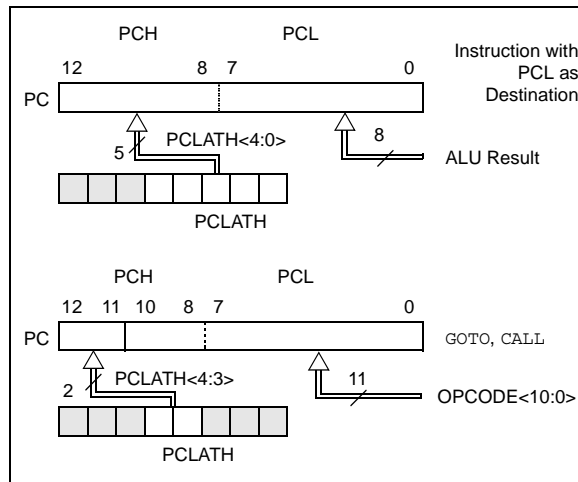

2.3.1 COMPUTED GOTO

A computed GOTO is accomplished by adding an offset to the program counter (ADDWF PCL). When performing a table read using a computed GOTO method, care should be exercised if the table location crosses a PCL memory boundary (each 256-byte block). Refer to the Application Note AN556, "Implementing a Table Read" (DS00556).

2.3.2 STACK

The PIC16F917/916/914/913 family has an 8-level x 13-bit wide hardware stack (see Figures 2-1 and 2-2). The stack space is not part of either program or data space and the Stack Pointer is not readable or writable. The PC is PUSHed onto the stack when a CALL instruction is executed or an interrupt causes a branch. The stack is POPed in the event of a RETURN, RETLW or a RETFIE instruction execution. PCLATH is not affected by a PUSH or POP operation.

The stack operates as a circular buffer. This means that after the stack has been PUSHed eight times, the ninth PUSH overwrites the value that was stored from the first PUSH. The tenth PUSH overwrites the second PUSH (and so on).

Note 1: There are no Status bits to indicate stack overflow or stack underflow conditions.

2: There are no instructions/mnemonics called PUSH or POP. These are actions that occur from the execution of the CALL, RETURN, RETLW and RETFIE instructions or the vectoring to an interrupt address.

2.4 Program Memory Paging

All PIC16F917/916/914/913 devices are capable of addressing a continuous 8K word block of program memory. The CALL and GOTO instructions provide only 11 bits of address to allow branching within any 2K program memory page. When doing a CALL or GOTO instruction, the upper 2 bits of the address are provided by PCLATH<4:3>. When doing a CALL or GOTO instruction, the user must ensure that the page select bits are programmed so that the desired program memory page is addressed. If a return from a CALL instruction (or interrupt) is executed, the entire 13-bit PC is POPed off the stack. Therefore, manipulation of the PCLATH<4:3> bits is not required for the RETURN instructions (which POPs the address from the stack).

Note: The contents of the PCLATH register are unchanged after a RETURN or RETFIE instruction is executed. The user must rewrite the contents of the PCLATH register for any subsequent subroutine calls or GOTO instructions.

Example 2-1 shows the calling of a subroutine in page 1 of the program memory. This example assumes that PCLATH is saved and restored by the Interrupt Service Routine (if interrupts are used).

EXAMPLE 2-1: CALL OF A SUBROUTINE IN PAGE 1 FROM PAGE 0

```

ORG 0x500
BCF PCLATH, 4
BSF PCLATH, 3 ;Select page 1
                ; (800h-FFFh)
CALL SUB1_P1 ;Call subroutine in
:                ;page 1 (800h-FFFh)
:
ORG 0x900 ;page 1 (800h-FFFh)
SUB1_P1
:                ;called subroutine
                ;page 1 (800h-FFFh)
:
RETURN ;return to
                ;Call subroutine
                ;in page 0
                ; (000h-7FFh)
    
```

PIC16F917/916/914/913

2.5 Indirect Addressing, INDF and FSR Registers

The INDF register is not a physical register. Addressing the INDF register will cause indirect addressing.

Indirect addressing is possible by using the INDF register. Any instruction using the INDF register actually accesses data pointed to by the File Select Register (FSR). Reading INDF itself indirectly will produce 00h. Writing to the INDF register indirectly results in a no operation (although Status bits may be affected). An effective 9-bit address is obtained by concatenating the 8-bit FSR register and the IRP bit (STATUS<7>), as shown in Figure 2-6.

A simple program to clear RAM location 20h-2Fh using indirect addressing is shown in Example 2-2.

EXAMPLE 2-2: INDIRECT ADDRESSING

```

MOVLW 0x20 ;initialize pointer
MOVWF FSR ;to RAM
NEXTCLR F INDF ;clear INDF register
INCF FSR ;inc pointer
BTFSS FSR,4 ;all done?
GOTO NEXT ;no clear next
CONTINUE ;yes continue
    
```

FIGURE 2-6: DIRECT/INDIRECT ADDRESSING PIC16F917/916/914/913

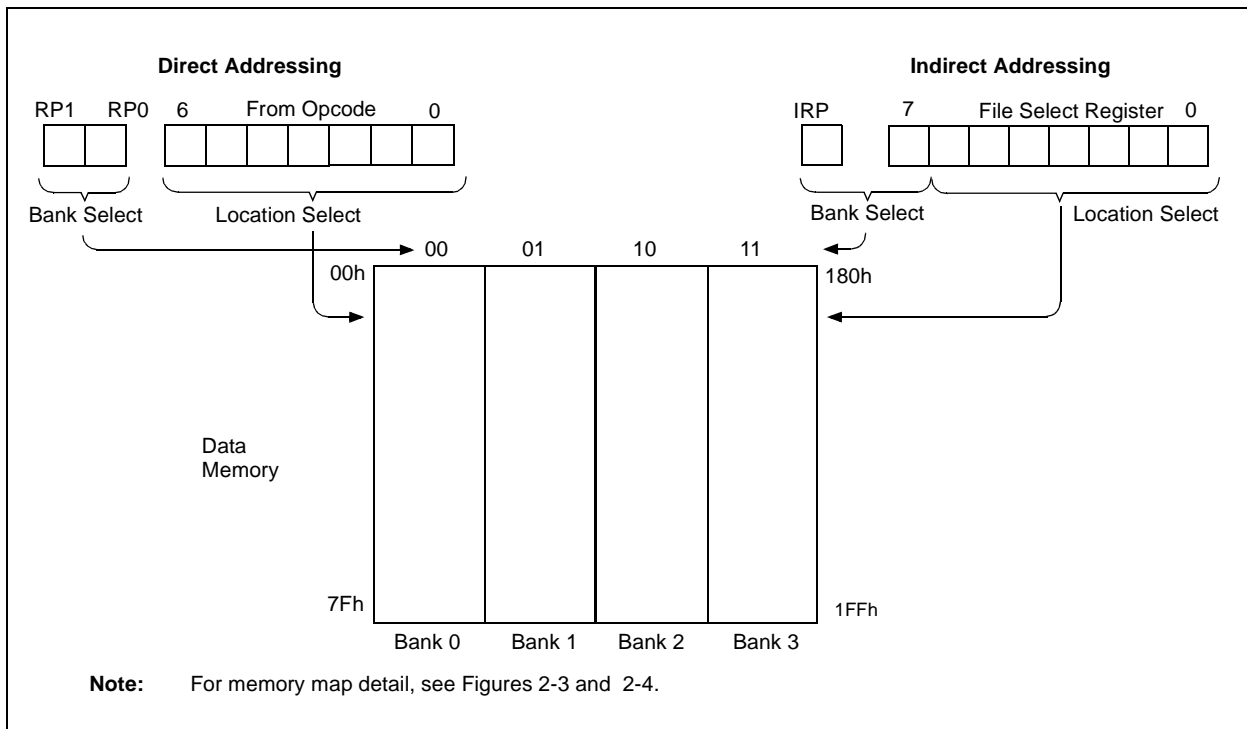

3.0 I/O PORTS

This device includes four 8-bit port registers along with their corresponding TRIS registers and one four bit port:

- PORTA and TRISA
- PORTB and TRISB
- PORTC and TRISC
- PORTD and TRISD
- PORTE and TRISE

PORTA, PORTB, PORTC and RE3/MCLR/VPP are implemented on all devices. PORTD and RE<2:0> are implemented only on the PIC16F914 and PIC16F917.

3.1 PORTA and TRISA Registers

PORTA is a 8-bit wide, bidirectional port. The corresponding data direction register is TRISA (Register 3-2). Setting a TRISA bit (= 1) will make the corresponding PORTA pin an input (i.e., put the corresponding output driver in a High-impedance mode). Clearing a TRISA bit (= 0) will make the corresponding PORTA pin an output (i.e., put the contents of the output latch on the selected pin). Example 3-1 shows how to initialize PORTA.

Five of the pins of PORTA can be configured as analog inputs. These pins, RA5 and RA<3:0>, are configured as analog inputs on device power-up and must be reconfigured by the user to be used as I/O's. This is done by writing the appropriate values to the CMCON0 and ANSEL registers (see Example 3-1).

Reading the PORTA register (Register 3-1) reads the status of the pins, whereas writing to it will write to the port latch. All write operations are read-modify-write operations. Therefore, a write to a port implies that the port pins are read, this value is modified and then written to the port data latch.

The TRISA register controls the direction of the PORTA pins, even when they are being used as analog inputs. The user must ensure the bits in the TRISA register are maintained set when using them as analog inputs. I/O pins configured as analog input always read '0'.

EXAMPLE 3-1: INITIALIZING PORTA

```
BCF    STATUS,RP0    ;Bank 0
BCF    STATUS,RP1    ;
CLRF   PORTA        ;Init PORTA
BSF    STATUS,RP0    ;Bank 1
BCF    STATUS,RP1    ;
MOVLW  07h          ;Set RA<2:0> to
MOVWF  CMCON0       ;digital I/O
CLF    ANSEL        ;Make all PORTA I/O
MOVLW  F0h          ;Set RA<7:4> as inputs
MOVWF  TRISA        ;and set RA<3:0>
                          ; as outputs
BCF    STATUS,RP0    ;Bank 0
BCF    STATUS,RP1    ;
```

Note 1: The CMCON0 (9Ch) register must be initialized to configure an analog channel as a digital input. Pins configured as analog inputs will read '0'.

2: Analog lines that carry LCD signals (i.e., SEGx, COMy, where x and y are segment and common identifiers) are shown as direct connections to the device pins. The signals are outputs from the LCD module and may be tri-stated, depending on the configuration of the LCD module.

PIC16F917/916/914/913

REGISTER 3-1: PORTA – PORTA REGISTER (ADDRESS: 05h)

R/W-x	R/W-x	R/W-x	R/W-x	R/W-x	R/W-x	R/W-x	R/W-x
RA7	RA6	RA5	RA4	RA3	RA2	RA1	RA0

bit 7 bit 0

bit 7-0 **RA<7:0>**: PORTA I/O Pin bits
1 = Port pin is >VIH
0 = Port pin is <VIL

Legend:			
R = Readable bit	W = Writable bit	U = Unimplemented bit, read as '0'	
- n = Value at POR	'1' = Bit is set	'0' = Bit is cleared	x = Bit is unknown

REGISTER 3-2: TRISA – PORTA TRI-STATE REGISTER (ADDRESS: 85h)

R/W-1	R/W-1	R/W-1	R/W-1	R/W-1	R/W-1	R/W-1	R/W-1
TRISA7	TRISA6	TRISA5	TRISA4	TRISA3	TRISA2	TRISA1	TRISA0

bit 7 bit 0

bit 7-0 **TRISA<7:0>**: PORTA Tri-State Control bits
1 = PORTA pin configured as an input (tri-stated)
0 = PORTA pin configured as an output

Note: TRISA<7:6> always reads '1' in XT, HS and LP OSC modes.

Legend:			
R = Readable bit	W = Writable bit	U = Unimplemented bit, read as '0'	
- n = Value at POR	'1' = Bit is set	'0' = Bit is cleared	x = Bit is unknown

3.1.1 PIN DESCRIPTIONS AND DIAGRAMS

Each PORTA pin is multiplexed with other functions. The pins and their combined functions are briefly described here. For specific information about individual functions, refer to the appropriate section in this data sheet.

3.1.1.1 RA0/AN0/C1-/SEG12

Figure 3-1 shows the diagram for this pin. The RA0/AN0/C1-/SEG12 pin is configurable to function as one of the following:

- a general purpose I/O
- an analog input for the A/D
- an analog input for Comparator 1
- an analog output for the LCD

FIGURE 3-1: BLOCK DIAGRAM OF RA0/AN0/C1-/SEG12

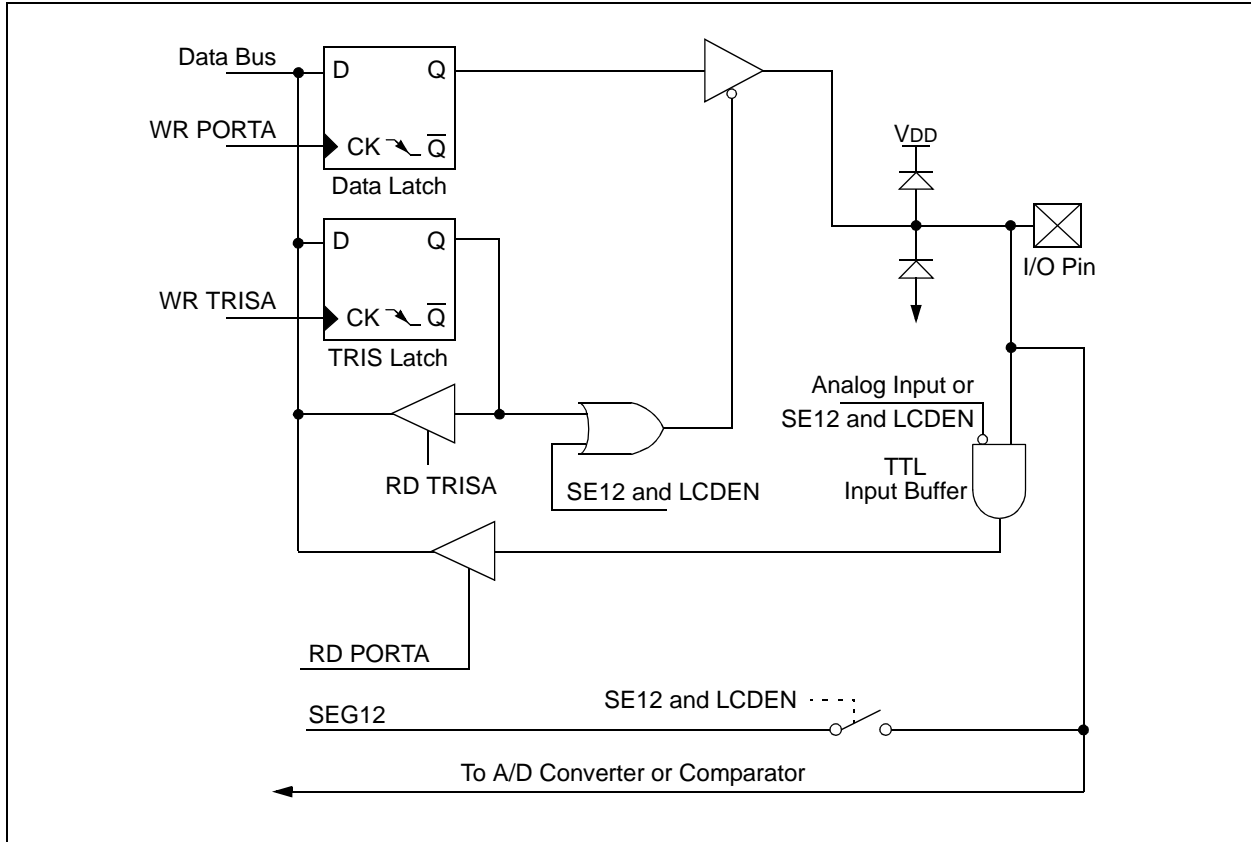

PIC16F917/916/914/913

3.1.1.2 RA1/AN1/C2-/SEG7

Figure 3-2 shows the diagram for this pin. The RA1/AN1/C2-/SEG7 pin is configurable to function as one of the following:

- a general purpose I/O
- an analog input for the A/D
- an analog input for Comparator 2
- an analog output for the LCD

FIGURE 3-2: BLOCK DIAGRAM OF RA1/AN1/C2-/SEG7

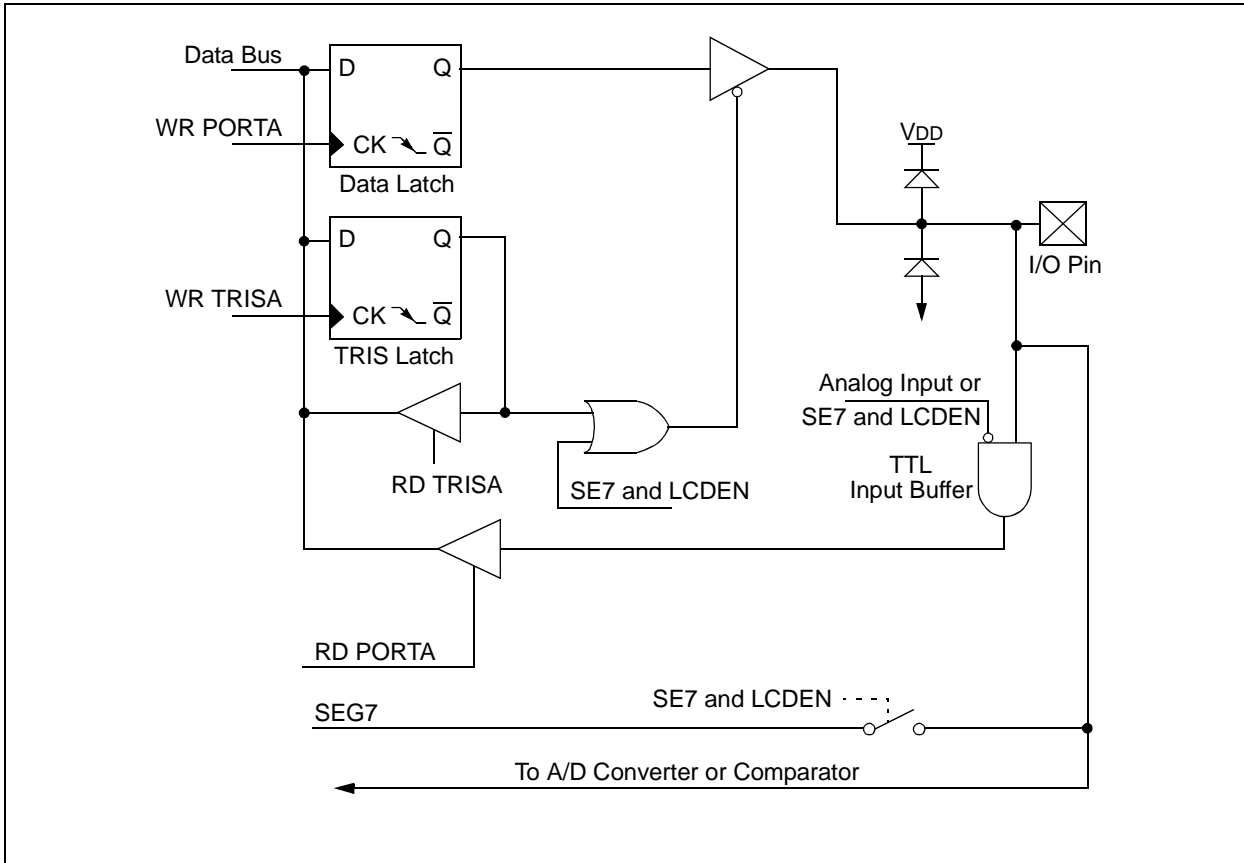

3.1.1.3 RA2/AN2/C2+/VREF-/COM2

Figure 3-3 shows the diagram for this pin. The RA2/AN2/C2+/VREF-/COM2 pin is configurable to function as one of the following:

- a general purpose I/O
- an analog input for the A/D
- an analog input for Comparator 2
- a voltage reference input for the A/D
- an analog output for the LCD

FIGURE 3-3: BLOCK DIAGRAM OF RA2/AN2/C2+/VREF-/COM2

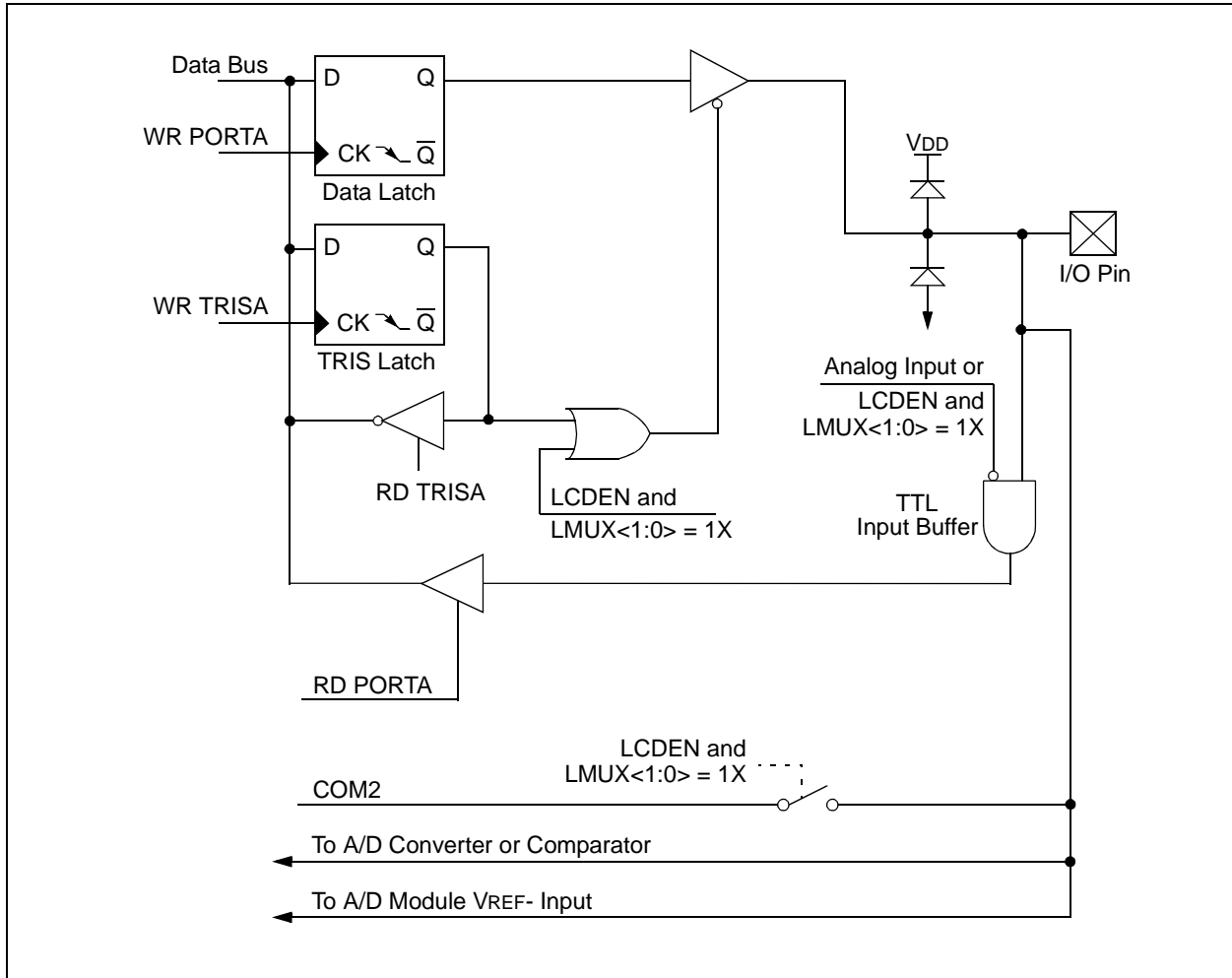

PIC16F917/916/914/913

3.1.1.4 RA3/AN3/C1+/VREF+/COM3/SEG15

Figure 3-4 shows the diagram for this pin. The RA3/AN3/C1+/VREF+/COM3/SEG15 pin is configurable to function as one of the following:

- a general purpose input
- an analog input for the A/D
- an analog input from Comparator 1
- a voltage reference input for the A/D
- analog outputs for the LCD

FIGURE 3-4: BLOCK DIAGRAM OF RA3/AN3/C1+/VREF+/COM3/SEG15

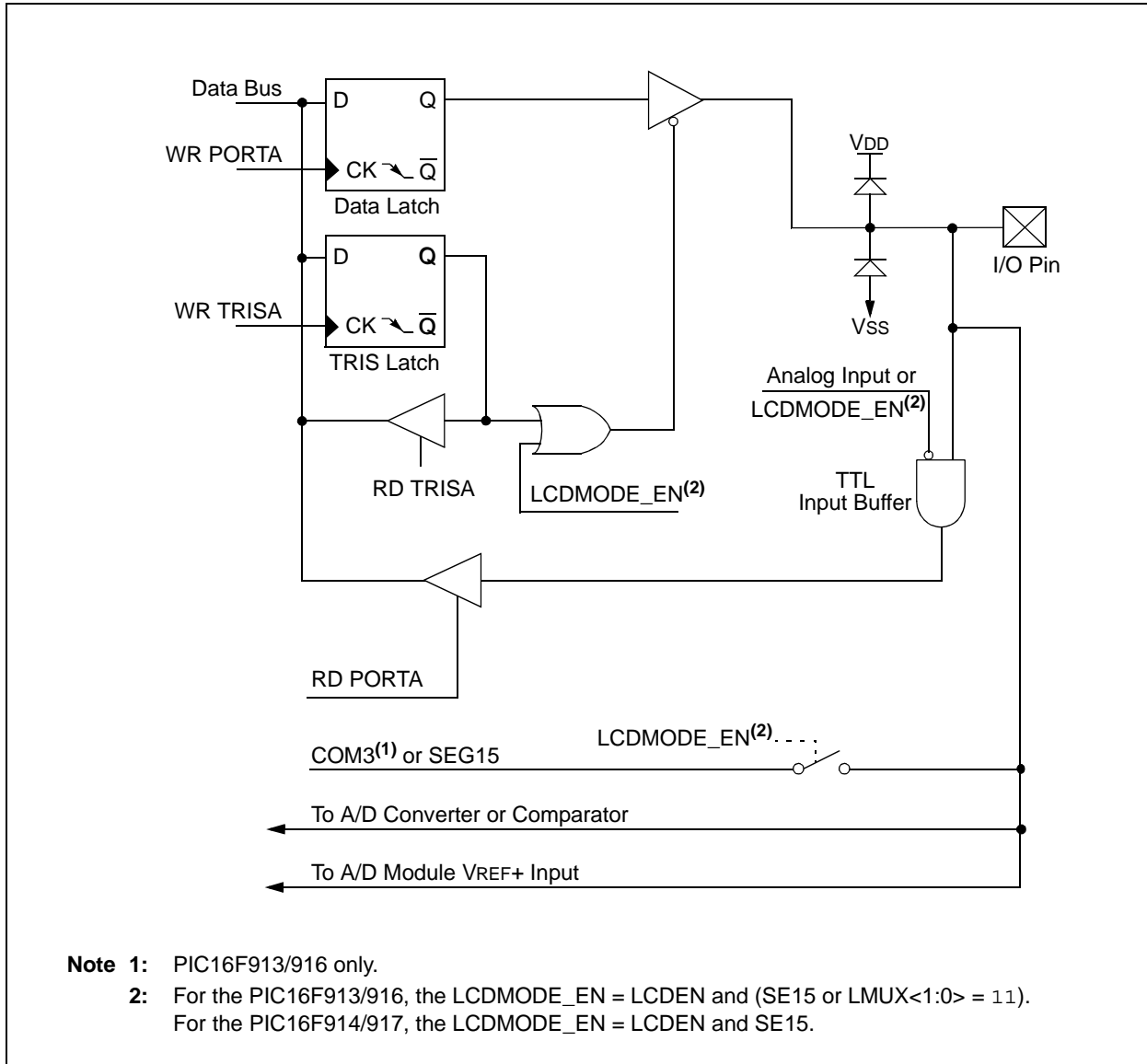

3.1.1.5 RA4/C1OUT/T0CKI/SEG4

Figure 3-5 shows the diagram for this pin. The RA4/C1OUT/T0CKI/SEG4 pin is configurable to function as one of the following:

- a general purpose I/O
- a digital output from Comparator 1
- a clock input for TMR0
- an analog output for the LCD

FIGURE 3-5: BLOCK DIAGRAM OF RA4/C1OUT/T0CKI/SEG4

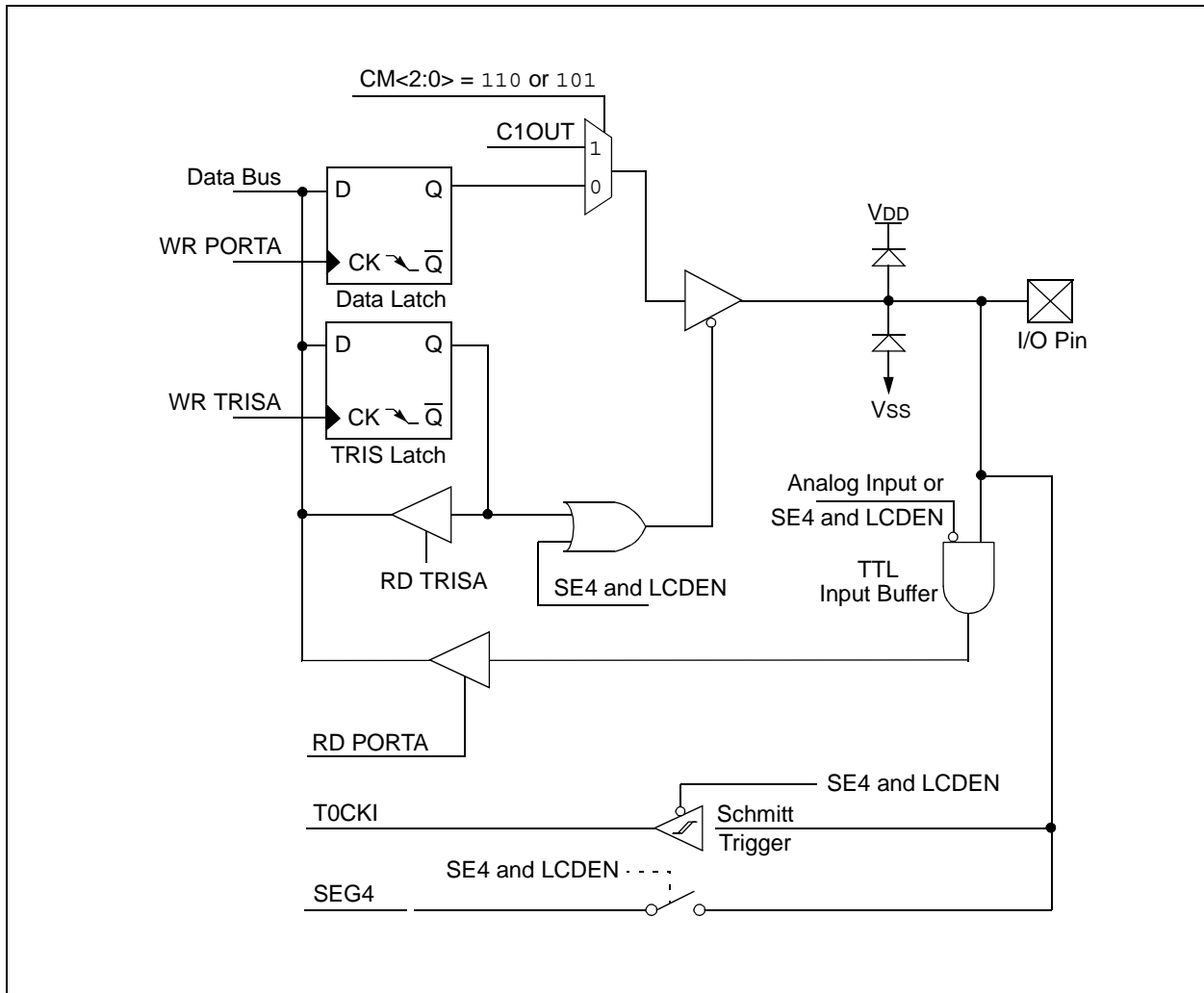

PIC16F917/916/914/913

3.1.1.6 RA5/AN4/C2OUT/ \overline{SS} /SEG5

Figure 3-6 shows the diagram for this pin. The RA5/AN4/C2OUT/ \overline{SS} /SEG5 pin is configurable to function as one of the following:

- a general purpose I/O
- a digital output from Comparator 2
- a slave select input
- an analog output for the LCD
- an analog input for the A/D

FIGURE 3-6: BLOCK DIAGRAM OF RA5/AN4/C2OUT/ \overline{SS} /SEG5

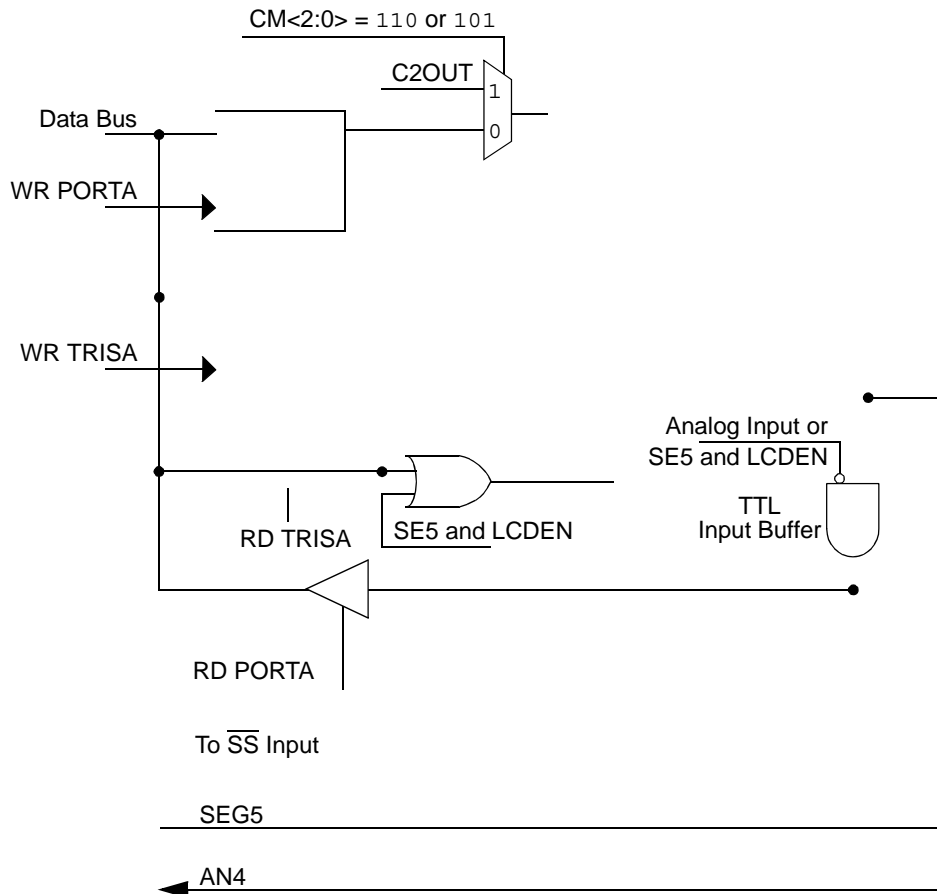

3.1.1.7 RA6/OSC2/CLKO/T1OSO

Figure 3-7 shows the diagram for this pin. The RA6/OSC2/CLKO/T1OSO pin is configurable to function as one of the following:

- a general purpose I/O
- a crystal/resonator connection
- a clock output
- a TMR1 oscillator connection

FIGURE 3-7: BLOCK DIAGRAM OF RA6/OSC2/CLKO/T1OSO

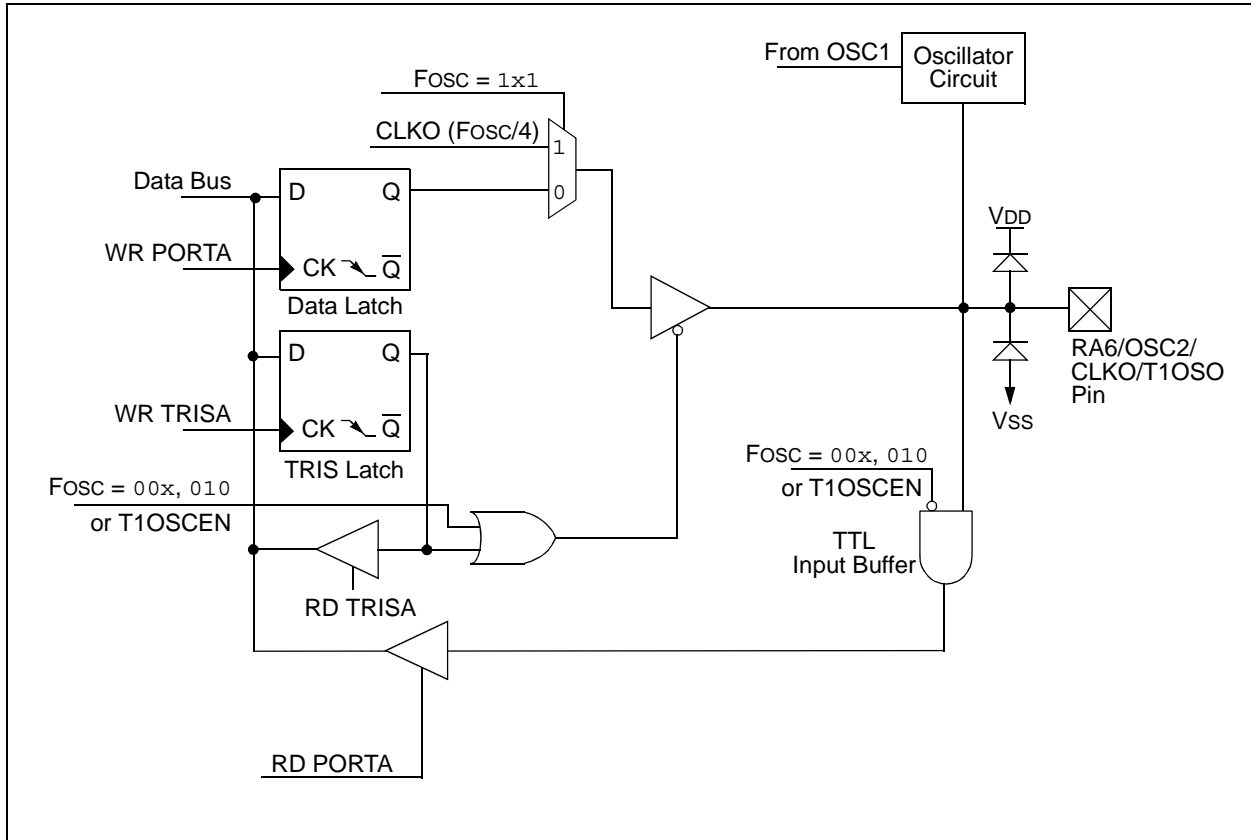

PIC16F917/916/914/913

3.1.1.8 RA7/OSC1/CLKI/T1OSI

Figure 3-8 shows the diagram for this pin. The RA7/OSC1/CLKI/T1OSI pin is configurable to function as one of the following:

- a general purpose I/O
- a crystal/resonator connection
- a clock input
- a TMR1 oscillator connection

FIGURE 3-8: BLOCK DIAGRAM OF RA7/OSC1/CLKI/T1OSI

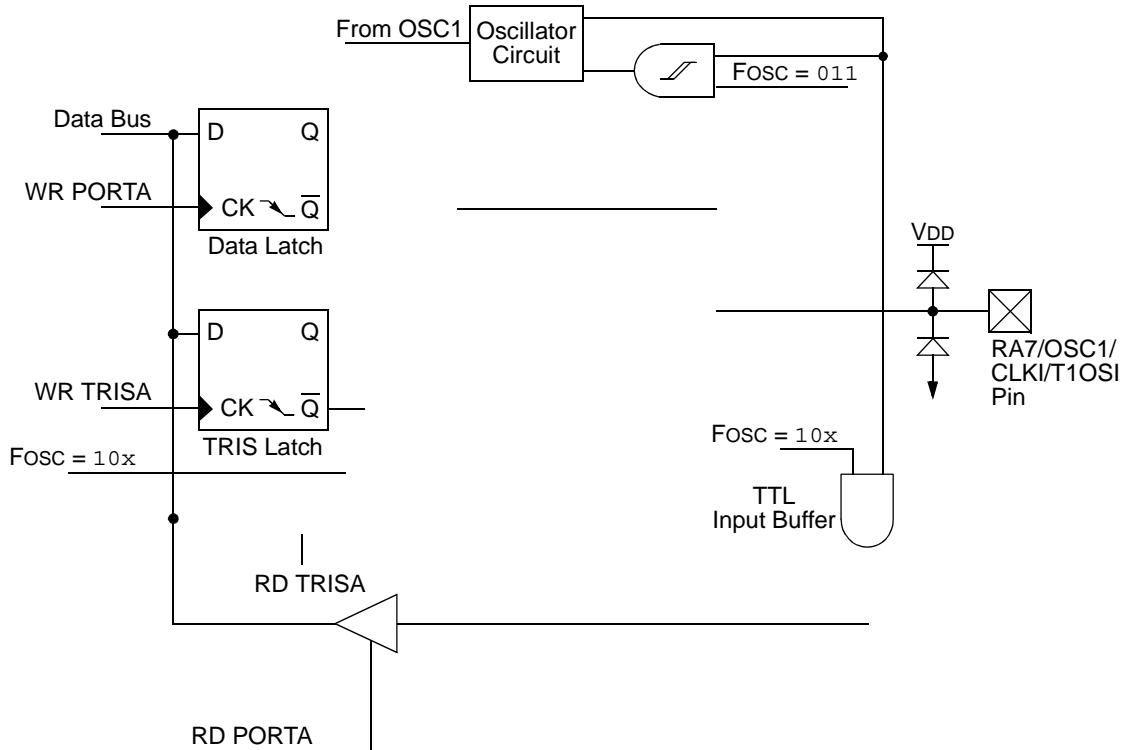

TABLE 3-1: SUMMARY OF REGISTERS ASSOCIATED WITH PORTA

Address	Name	Bit 7	Bit 6	Bit 5	Bit 4	Bit 3	Bit 2	Bit 1	Bit 0	Value on: POR, BOR	Value on all other Resets
05h	PORTA	RA7	RA6	RA5	RA4	RA3	RA2	RA1	RA0	xxxx xxxx	uuuu uuuu
10h	T1CON	T1GINV	T1GE	T1CKPS1	T1CKPS0	T1OSCEN	T1SYNC	TMR1CS	TMR1ON	0000 0000	uuuu uuuu
14h	SSPCON	WCOL	SSPOV	SSPEN	CKP	SSPM3	SSPM2	SSPM1	SSPM0	0000 0000	0000 0000
1Fh	ADCON0	ADFM	VCFG1	VCFG0	CHS2	CHS1	CHS0	GO/DONE	ADON	0000 0000	0000 0000
81h/181h	OPTION_REG	RBPU	INTEDG	T0CS	T0SE	PSA	PS2	PS1	PS0	1111 1111	1111 1111
85h	TRISA	TRISA7	TRISA6	TRISA5	TRISA4	TRISA3	TRISA2	TRISA1	TRISA0	1111 1111	1111 1111
91h	ANSEL	ANS7	ANS6	ANS5	ANS4	ANS3	ANS2	ANS1	ANS0	1111 1111	1111 1111
9Ch	CMCON0	C2OUT	C1OUT	C2INV	C1INV	CIS	CM2	CM1	CM0	0000 0000	0000 0000
107h	LCDCON	LCDEN	SLPEN	WERR	VLCDEN	CS1	CS0	LMUX1	LMUX0	0001 0011	0001 0011
11Ch	LCDSE0 ⁽¹⁾	SE7	SE6	SE5	SE4	SE3	SE2	SE1	SE0	0000 0000	uuuu uuuu
11Dh	LCDSE1 ⁽¹⁾	SE15	SE14	SE13	SE12	SE11	SE10	SE9	SE8	0000 0000	uuuu uuuu

Legend: x = unknown, u = unchanged, - = unimplemented locations read as '0'. Shaded cells are not used by PORTA.
Note 1: This register is only initialized by a POR or BOR reset and is unchanged by other Resets.

3.2 PORTB and TRISB Registers

PORTB is a general purpose I/O port with similar functionality as the PIC16F77. All PORTB pins can have a weak pull-up feature, and PORTB<7:4> implements an interrupt-on-input change function.

PORTB is also used for the Serial Flash programming interface.

Note: Analog lines that carry LCD signals (i.e., SEG_x, COM_y, where x and y are segment and common identifiers) are shown as direct connections to the device pins. The signals are outputs from the LCD module and may be tri-stated, depending on the configuration of the LCD module.

EXAMPLE 3-2: INITIALIZING PORTB

```
BCF    STATUS,RP0    ;Bank 0
BCF    STATUS,RP1    ;
CLRF   PORTB        ;Init PORTB
BSF    STATUS,RP0    ;Bank 1
BCF    STATUS,RP1    ;
MOVLW  FFh          ;Set RB<7:0> as inputs
MOVWF  TRISB        ;
BCF    STATUS,RP0    ;Bank 0
BCF    STATUS,RP1    ;
```

3.3 Additional PORTB Pin Functions

RB<7:6> are used as data and clock signals, respectively, for both serial programming and the in-circuit debugger features on the device. Also, RB0 can be configured as an external interrupt input.

3.3.1 WEAK PULL-UPS

Each of the PORTB pins has an individually configurable internal weak pull-up. Control bits WPUB<7:0> enable or disable each pull-up. Refer to Register 3-6. Each weak pull-up is automatically turned off when the port pin is configured as an output. The pull-ups are disabled on a Power-on Reset by the RBPU bit (OPTION_REG<7>).

3.3.2 INTERRUPT-ON-CHANGE

Four of the PORTB pins are individually configurable as an interrupt-on-change pin. Control bits IOCB<7:4> enable or disable the interrupt function for each pin. Refer to Register 3-5. The interrupt-on-change feature is disabled on a Power-on Reset.

For enabled interrupt-on-change pins, the values are compared with the old value latched on the last read of PORTB. The 'mismatch' outputs of the last read are OR'd together to set the PORTB Change Interrupt flag bit (RBIF) in the INTCON register (Register 2-3).

This interrupt can wake the device from Sleep. The user, in the Interrupt Service Routine, clears the interrupt by:

- Any read or write of PORTB. This will end the mismatch condition.
- Clear the flag bit RBIF.

A mismatch condition will continue to set flag bit RBIF. Reading or writing PORTB will end the mismatch condition and allow flag bit RBIF to be cleared. The latch holding the last read value is not affected by a MCLR nor Brown-out Reset. After these Resets, the RBIF flag will continue to be set if a mismatch is present.

Note: If a change on the I/O pin should occur when the read operation is being executed (start of the Q2 cycle), then the RBIF interrupt flag may not get set. Furthermore, since a read or write on a port affects all bits of that port, care must be taken when using multiple pins in Interrupt-on-change mode. Changes on one pin may not be seen while servicing changes on another pin.

PIC16F917/916/914/913

REGISTER 3-3: PORTB – PORTB REGISTER (ADDRESS: 06h OR 106h)

R/W-x	R/W-x	R/W-x	R/W-x	R/W-x	R/W-x	R/W-x	R/W-x
RB7	RB6	RB5	RB4	RB3	RB2	RB1	RB0
bit 7				bit 0			

bit 7-0 **RB<7:0>**: PORTB I/O Pin bits
 1 = Port pin is >VIH
 0 = Port pin is <VIL

Legend:			
R = Readable bit	W = Writable bit	U = Unimplemented bit, read as '0'	
- n = Value at POR	'1' = Bit is set	'0' = Bit is cleared	x = Bit is unknown

REGISTER 3-4: TRISB – PORTB TRI-STATE REGISTER (ADDRESS: 86h, 186h)

R/W-1	R/W-1	R/W-1	R/W-1	R/W-1	R/W-1	R/W-1	R/W-1
TRISB7	TRISB6	TRISB5	TRISB4	TRISB3	TRISB2	TRISB1	TRISB0
bit 7				bit 0			

bit 7-0 **TRISB<7:0>**: PORTB Tri-State Control bits
 1 = PORTB pin configured as an input (tri-stated)
 0 = PORTB pin configured as an output

Note: TRISB<7:6> always reads '1' in XT, HS and LP OSC modes.

Legend:			
R = Readable bit	W = Writable bit	U = Unimplemented bit, read as '0'	
- n = Value at POR	'1' = Bit is set	'0' = Bit is cleared	x = Bit is unknown

REGISTER 3-5: IOCB – PORTB INTERRUPT-ON-CHANGE REGISTER (ADDRESS: 96h)

R/W-0	R/W-0	R/W-0	R/W-0	U-0	U-0	U-0	U-0
IOCB7	IOCB6	IOCB5	IOCB4	—	—	—	—
bit 7				bit 0			

bit 7-4 **IOCB<7:4>**: Interrupt-on-Change bits
 1 = Interrupt-on-change enabled
 0 = Interrupt-on-change disabled

bit 3-0 **Unimplemented:** Read as '0'

Legend:			
R = Readable bit	W = Writable bit	U = Unimplemented bit, read as '0'	
- n = Value at POR	'1' = Bit is set	'0' = Bit is cleared	x = Bit is unknown

PIC16F917/916/914/913

REGISTER 3-6: WPUB – WEAK PULL-UP REGISTER (ADDRESS: 95h)

R/W-1	R/W-1	R/W-1	R/W-1	R/W-1	R/W-1	R/W-1	R/W-1
WPUB7	WPUB6	WPUB5	WPUB4	WPUB3	WPUB2	WPUB1	WPUB0

bit 7 bit 0

bit 7-0 **WPUB<7:0>**: Weak Pull-up Register bits

1 = Pull-up enabled

0 = Pull-up disabled

Note 1: Global $\overline{\text{RBPU}}$ must be enabled for individual pull-ups to be enabled.

Note 2: The weak pull-up device is automatically disabled if the pin is in Output mode ($\text{TRISB}<7:0> = 0$).

Legend:

R = Readable bit

W = Writable bit

U = Unimplemented bit, read as '0'

- n = Value at POR

'1' = Bit is set

'0' = Bit is cleared

x = Bit is unknown

PIC16F917/916/914/913

3.3.3 PIN DESCRIPTIONS AND DIAGRAMS

Each PORTB pin is multiplexed with other functions. The pins and their combined functions are briefly described here. For specific information about individual functions such as the LCD or interrupts, refer to the appropriate section in this data sheet.

3.3.3.1 RB0/INT/SEG0

Figure 3-9 shows the diagram for this pin. The RB0/INT/SEG0 pin is configurable to function as one of the following:

- a general purpose I/O
- an external edge triggered interrupt
- an analog output for the LCD

3.3.3.2 RB1/SEG1

Figure 3-9 shows the diagram for this pin. The RB1/SEG1 pin is configurable to function as one of the following:

- a general purpose I/O
- an analog output for the LCD

3.3.3.3 RB2/SEG2

Figure 3-9 shows the diagram for this pin. The RB2/SEG2 pin is configurable to function as one of the following:

- a general purpose I/O
- an analog output for the LCD

3.3.3.4 RB3/SEG3

Figure 3-9 shows the diagram for this pin. The RB3/SEG3 pin is configurable to function as one of the following:

- a general purpose I/O
- an analog output for the LCD

3.3.3.6 RB5/COM1

Figure 3-11 shows the diagram for this pin. The RB5/COM1 pin is configurable to function as one of the following:

- a general purpose I/O
- an analog output for the LCD

FIGURE 3-11: BLOCK DIAGRAM OF RB5/COM1

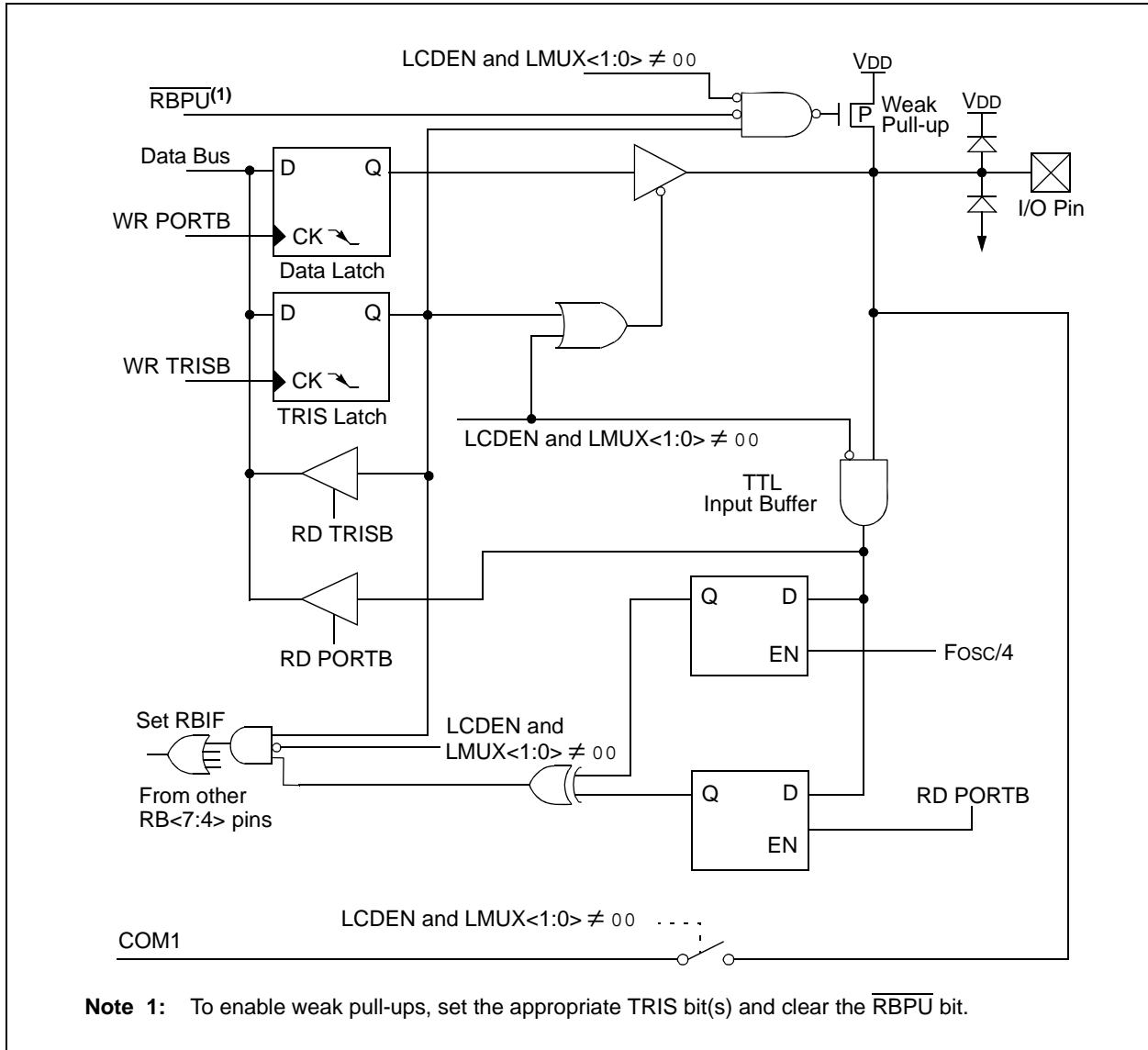

PIC16F917/916/914/913

3.3.3.7 RB6/ICSPCLK/ICDCK/SEG14

Figure 3-12 shows the diagram for this pin. The RB6/ICSPCLK/ICDCK/SEG14 pin is configurable to function as one of the following:

- a general purpose I/O
- an In-Circuit Serial Programming™ clock
- an ICD clock I/O
- an analog output for the LCD

FIGURE 3-12: BLOCK DIAGRAM OF RB6/ICSPCLK/ICDCK/SEG14

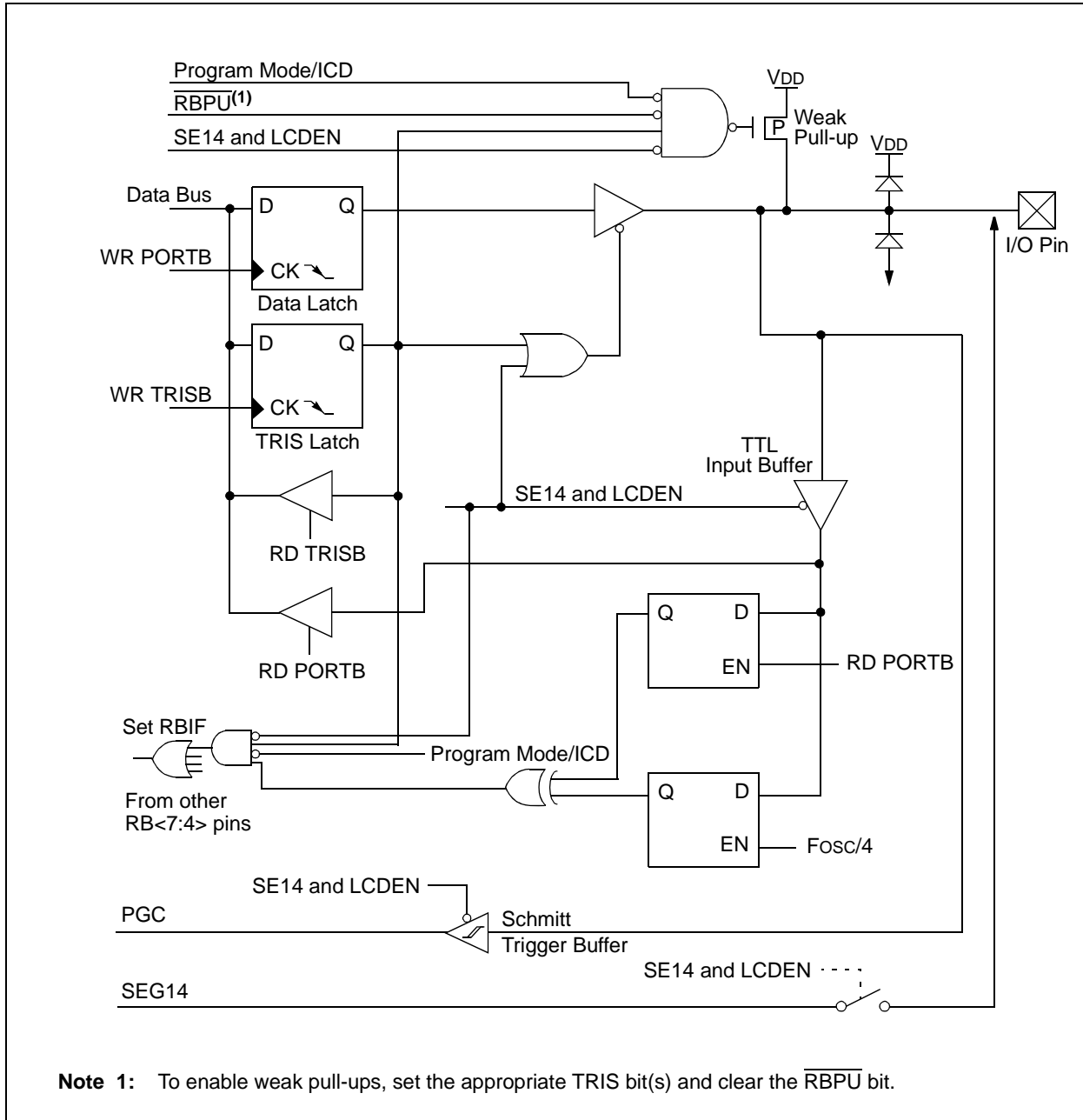

3.3.3.8 RB7/ICSPDAT/ICDDAT/SEG13

Figure 3-13 shows the diagram for this pin. The RB7/ICSPDAT/ICDDAT/SEG13 pin is configurable to function as one of the following:

- a general purpose I/O
- an In-Circuit Serial Programming™ I/O
- an ICD data I/O
- an analog output for the LCD

FIGURE 3-13: BLOCK DIAGRAM OF RB7/ICSPDAT/ICDDAT/SEG13

$\overline{\text{PORT}}$ /Program Mode/ICD

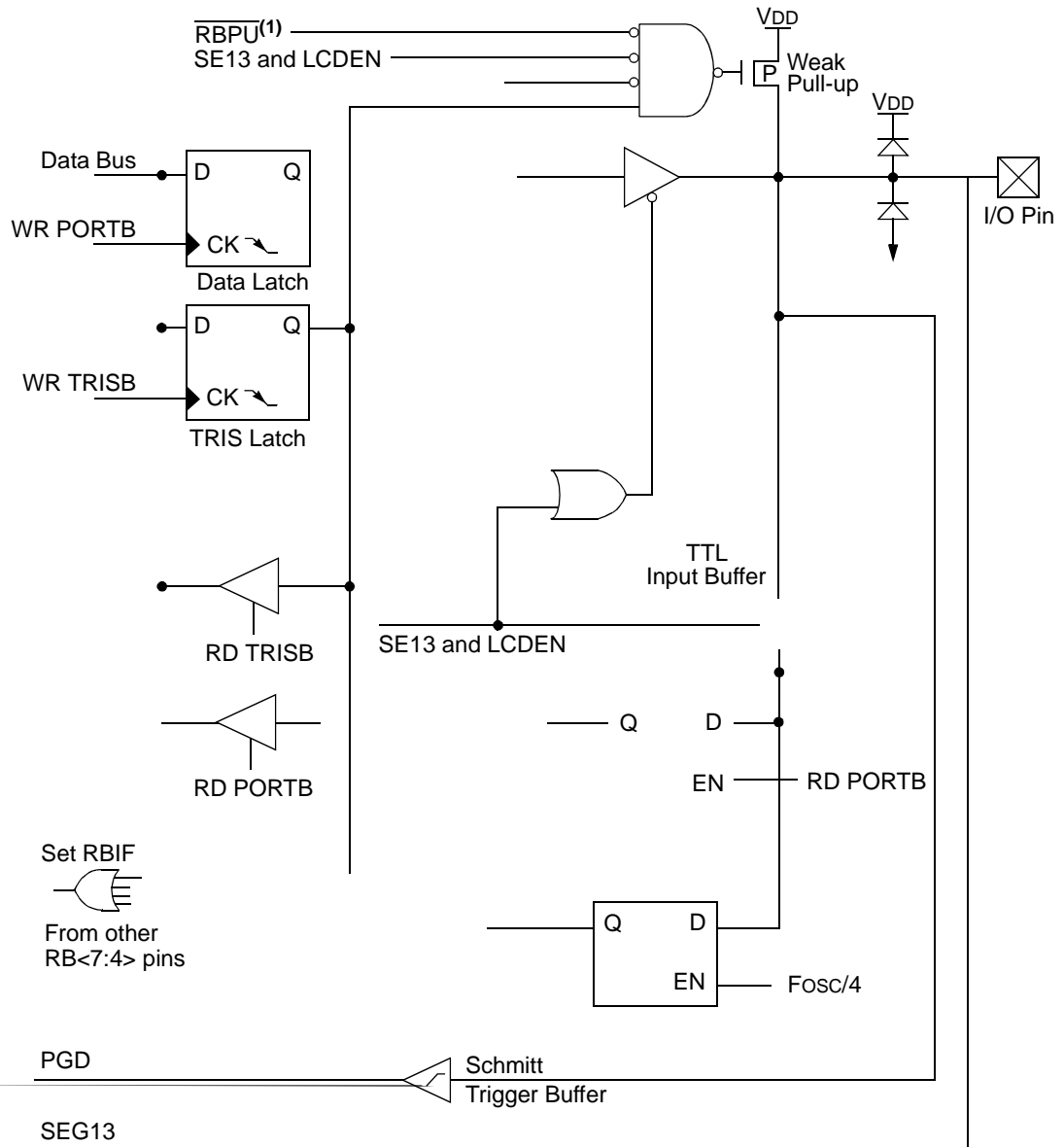

Note 1: To enable weak pull-ups, set the appropriate TRIS bit(s) and clear the $\overline{\text{RBP}}\text{U}$ bit.

PIC16F917/916/914/913

TABLE 3-2: SUMMARY OF REGISTERS ASSOCIATED WITH PORTB

Address	Name	Bit 7	Bit 6	Bit 5	Bit 4	Bit 3	Bit 2	Bit 1	Bit 0	Value on: POR, BOR	Value on all other Resets
06h/106h	PORTB	RB7	RB6	RB5	RB4	RB3	RB2	RB1	RB0	xxxx xxxx	uuuu uuuu
86h/186h	TRISB	TRISB7	TRISB6	TRISB5	TRISB4	TRISB3	TRISB2	TRISB1	TRISB0	1111 1111	1111 1111
0Bh/8Bh/ 10Bh/18Bh	INTCON	GIE	PEIE	T0IE	INTE	RBIE	T0IF	INTF	RBIF	0000 000x	0000 000x
95h	WPUB	WPUB7	WPUB6	WPUB5	WPUB4	WPUB3	WPUB2	WPUB1	WPUB0	1111 1111	1111 1111
96h	IOCB	IOCB7	IOCB6	IOCB5	IOCB4	—	—	—	—	0000 ----	0000 ----
107h	LCDCON	LCDEN	SLPEN	WERR	VLCDEN	CS1	CS0	LMUX1	LMUX0	0001 0011	0001 0011
11Ch	LCDSE0 ⁽¹⁾	SE7	SE6	SE5	SE4	SE3	SE2	SE1	SE0	0000 0000	uuuu uuuu
11Dh	LCDSE1 ⁽¹⁾	SE15	SE14	SE13	SE12	SE11	SE10	SE9	SE8	0000 0000	uuuu uuuu

Legend: x = unknown, u = unchanged, - = unimplemented locations read as '0'. Shaded cells are not used by PORTB.

Note 1: This register is only initialized by a POR or BOR reset and is unchanged by other Resets.

3.4 PORTC and TRISC Registers

PORTC is an 8-bit bidirectional port. PORTC is multiplexed with several peripheral functions. PORTC pins have Schmitt Trigger input buffers.

All PORTC pins have latch bits (PORTC register). They, when written, will modify the contents of the PORTC latch; thus, modifying the value driven out on a pin if the corresponding TRISC bit is configured for output.

Note: Analog lines that carry LCD signals (i.e., SEGx, VLCDy, where x and y are segment and LCD bias voltage identifiers) are shown as direct connections to the device pins. The signals are outputs from the LCD module and may be tri-stated, depending on the configuration of the LCD module.

EXAMPLE 3-3: INITIALIZING PORTC

```
BCF STATUS,RP0 ;Bank 0
BCF STATUS,RP1 ;
CLRF PORTC ;Init PORTC
BSF STATUS,RP0 ;Bank 1
BCF STATUS,RP1 ;
MOVLW FFh ;Set RC<7:0> as inputs
MOVWF TRISC ;
BCF STATUS,RP0 ;Bank 2
BSF STATUS,RP1 ;
CLRF LDCON ;Disable VLCD<3:1>
;inputs on RC<2:0>
BCF STATUS,RP0 ;Bank 0
BCF STATUS,RP1 ;
```

REGISTER 3-7: PORTC – PORTC REGISTER (ADDRESS: 07h)

R/W-x	R/W-x	R/W-x	R/W-x	R/W-x	R/W-x	R/W-x	R/W-x	R/W-x
RC7	RC6	RC5	RC4	RC3	RC2	RC1	RC0	
bit 7							bit 0	

bit 7-0 **RC<7:0>**: PORTC I/O Pin bits
 1 = Port pin is >VIH
 0 = Port pin is <VIL

Legend:

R = Readable bit W = Writable bit U = Unimplemented bit, read as '0'
 - n = Value at POR '1' = Bit is set '0' = Bit is cleared x = Bit is unknown

REGISTER 3-8: TRISC – PORTC TRI-STATE REGISTER (ADDRESS: 87h)

R/W-1	R/W-1	R/W-1	R/W-1	R/W-1	R/W-1	R/W-1	R/W-1
TRISC7	TRISC6	TRISC5	TRISC4	TRISC3	TRISC2	TRISC1	TRISC0
bit 7						bit 0	

bit 7-0 **TRISC<7:0>**: PORTC Tri-State Control bits
 1 = PORTC pin configured as an input (tri-stated)
 0 = PORTC pin configured as an output

Note: TRISC<7:6> always reads '1' in XT, HS and LP OSC modes.

Legend:

R = Readable bit W = Writable bit U = Unimplemented bit, read as '0'
 - n = Value at POR '1' = Bit is set '0' = Bit is cleared x = Bit is unknown

PIC16F917/916/914/913

3.4.1 PIN DESCRIPTIONS AND DIAGRAMS

Each PORTC pin is multiplexed with other functions. The pins and their combined functions are briefly described here. For specific information about individual functions such as the LCD or SSP, refer to the appropriate section in this data sheet.

3.4.1.1 RC0/VLCD1

Figure 3-14 shows the diagram for this pin. The RC0/VLCD1 pin is configurable to function as one of the following:

- a general purpose I/O
- an analog input for the LCD bias voltage

3.4.1.2 RC1/VLCD2

Figure 3-15 shows the diagram for this pin. The RC1/VLCD2 pin is configurable to function as one of the following:

- a general purpose I/O
- an analog input for the LCD bias voltage

3.4.1.3 RC2/VLCD3

Figure 3-16 shows the diagram for this pin. The RC2/VLCD3 pin is configurable to function as one of the following:

- a general purpose I/O
- an analog input for the LCD bias voltage

FIGURE 3-14: BLOCK DIAGRAM OF RC0/VLCD1

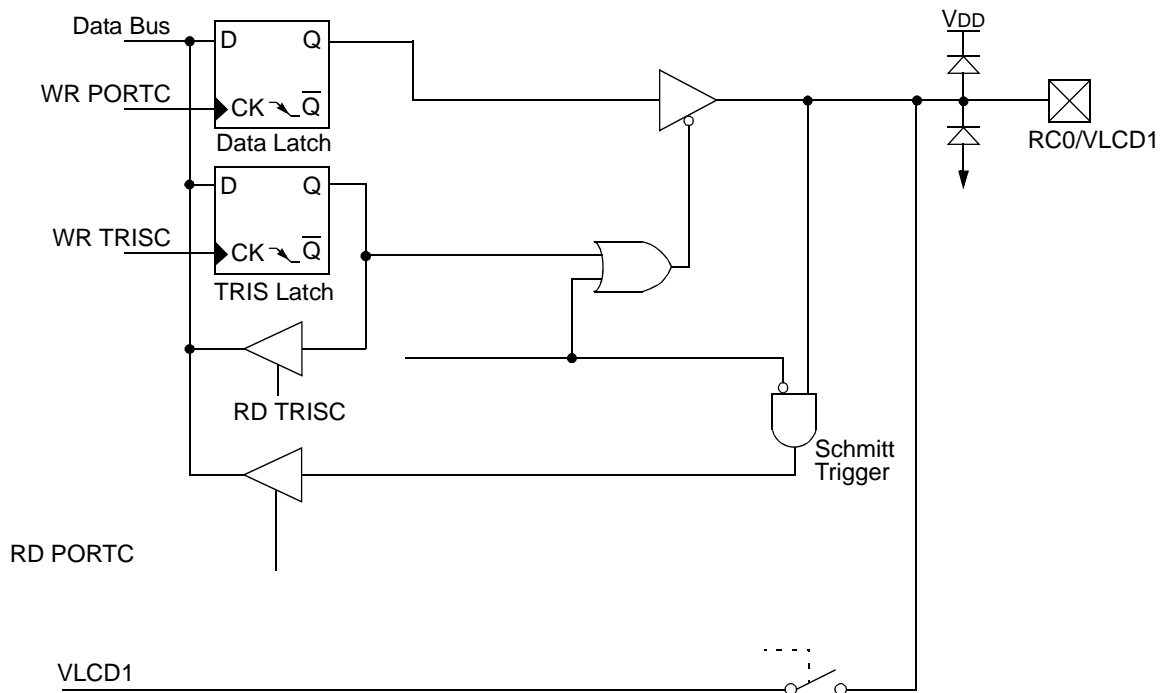

FIGURE 3-15: BLOCK DIAGRAM OF RC1/VLCD2

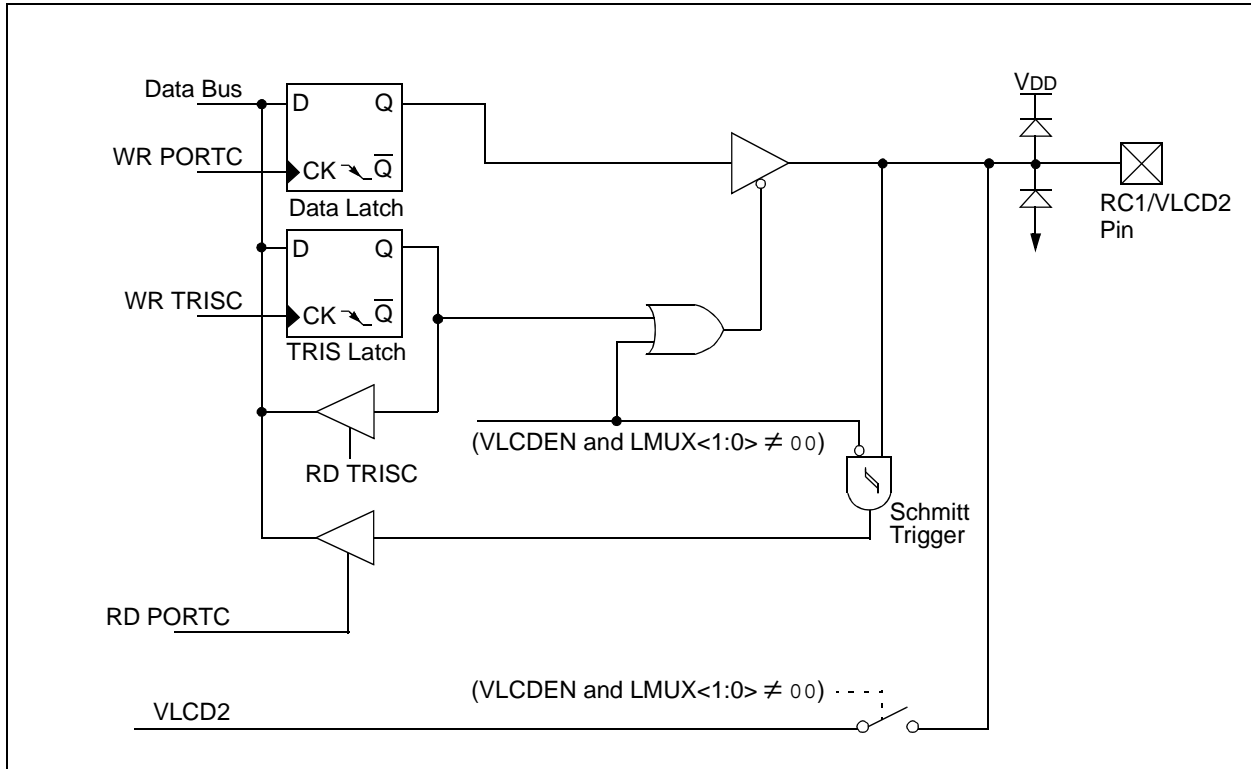
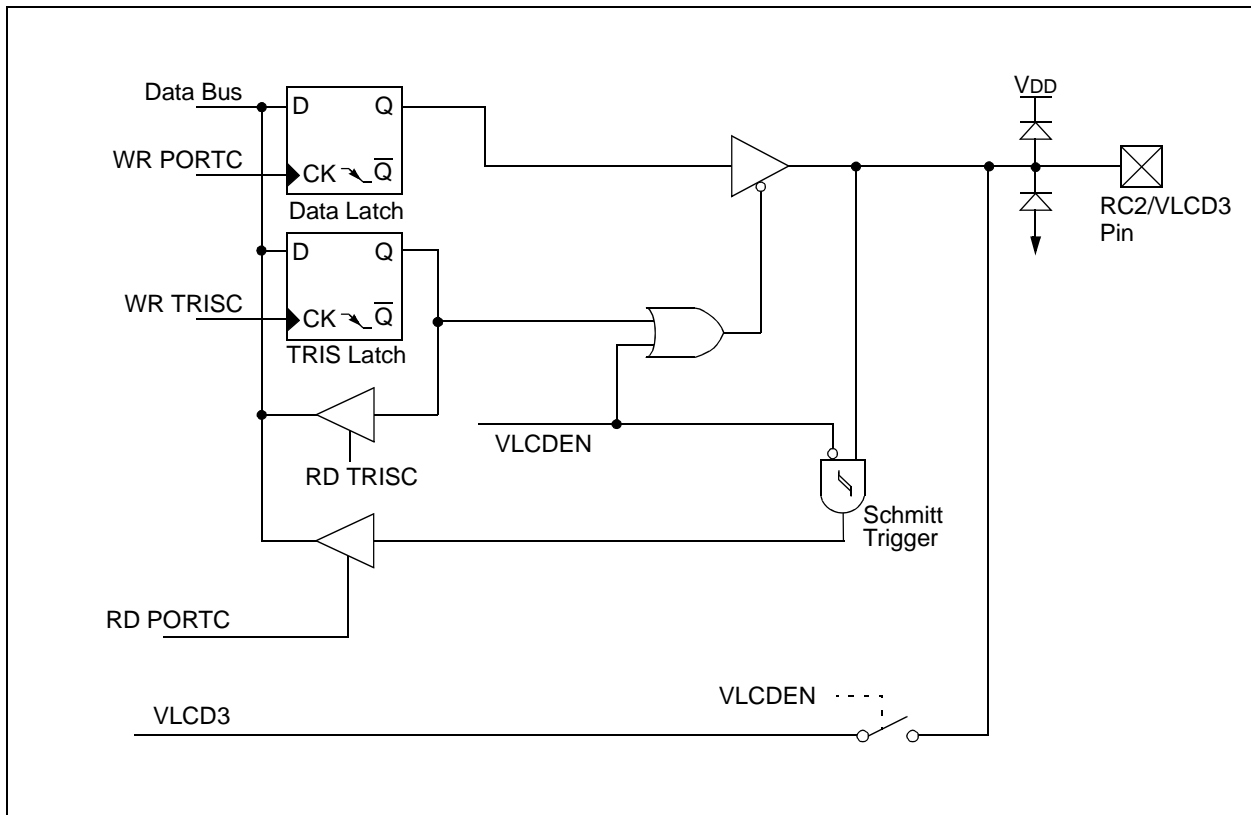

FIGURE 3-16: BLOCK DIAGRAM OF RC2/VLCD3



PIC16F917/916/914/913

3.4.1.4 RC3/SEG6

Figure 3-17 shows the diagram for this pin. The RC3/SEG6 pin is configurable to function as one of the following:

- a general purpose I/O
- an analog output for the LCD

FIGURE 3-17: BLOCK DIAGRAM OF RC3/SEG6

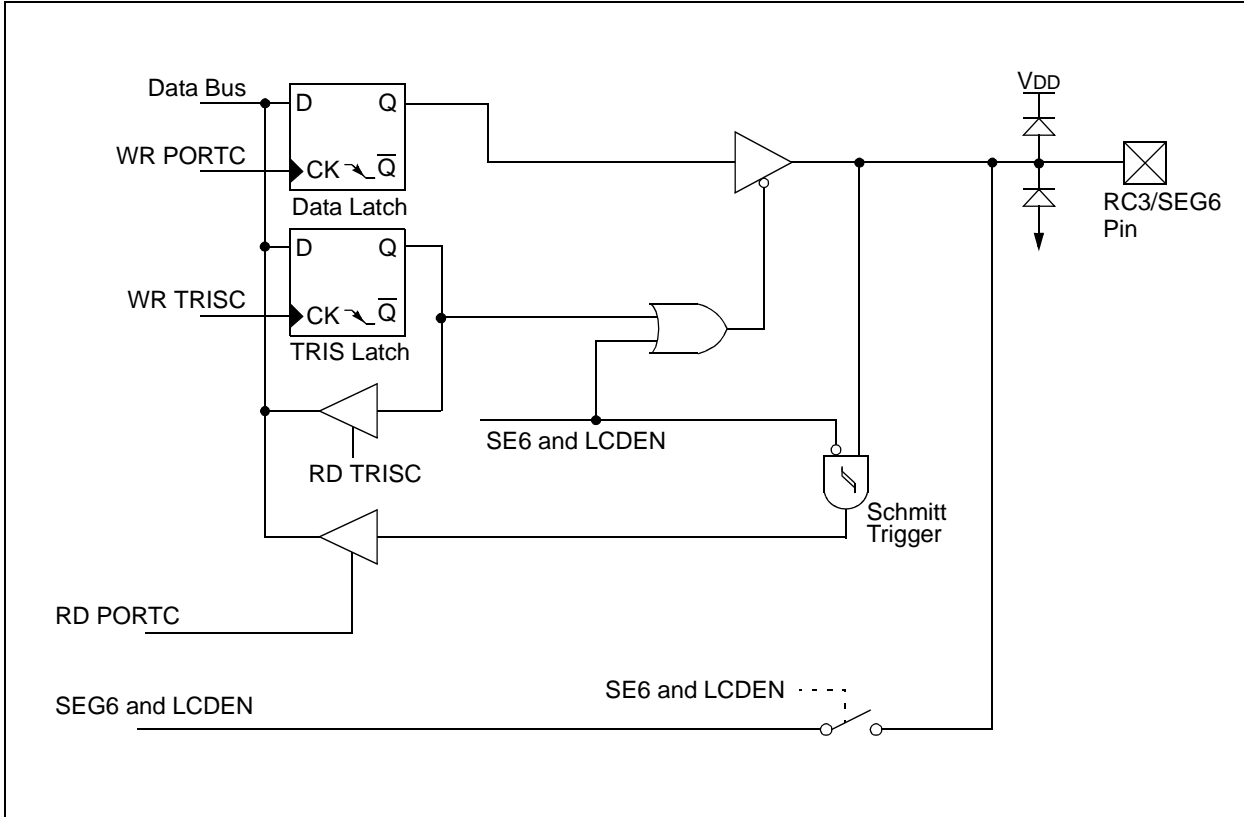

3.4.1.5 RC4/T1G/SDO/SEG11

Figure 3-18 shows the diagram for this pin. The RC4/T1G/SDO/SEG11 pin is configurable to function as one of the following:

- a general purpose I/O
- a TMR1 gate input
- a serial data output
- an analog output for the LCD

FIGURE 3-18: BLOCK DIAGRAM OF RC4/T1G/SDO/SEG11

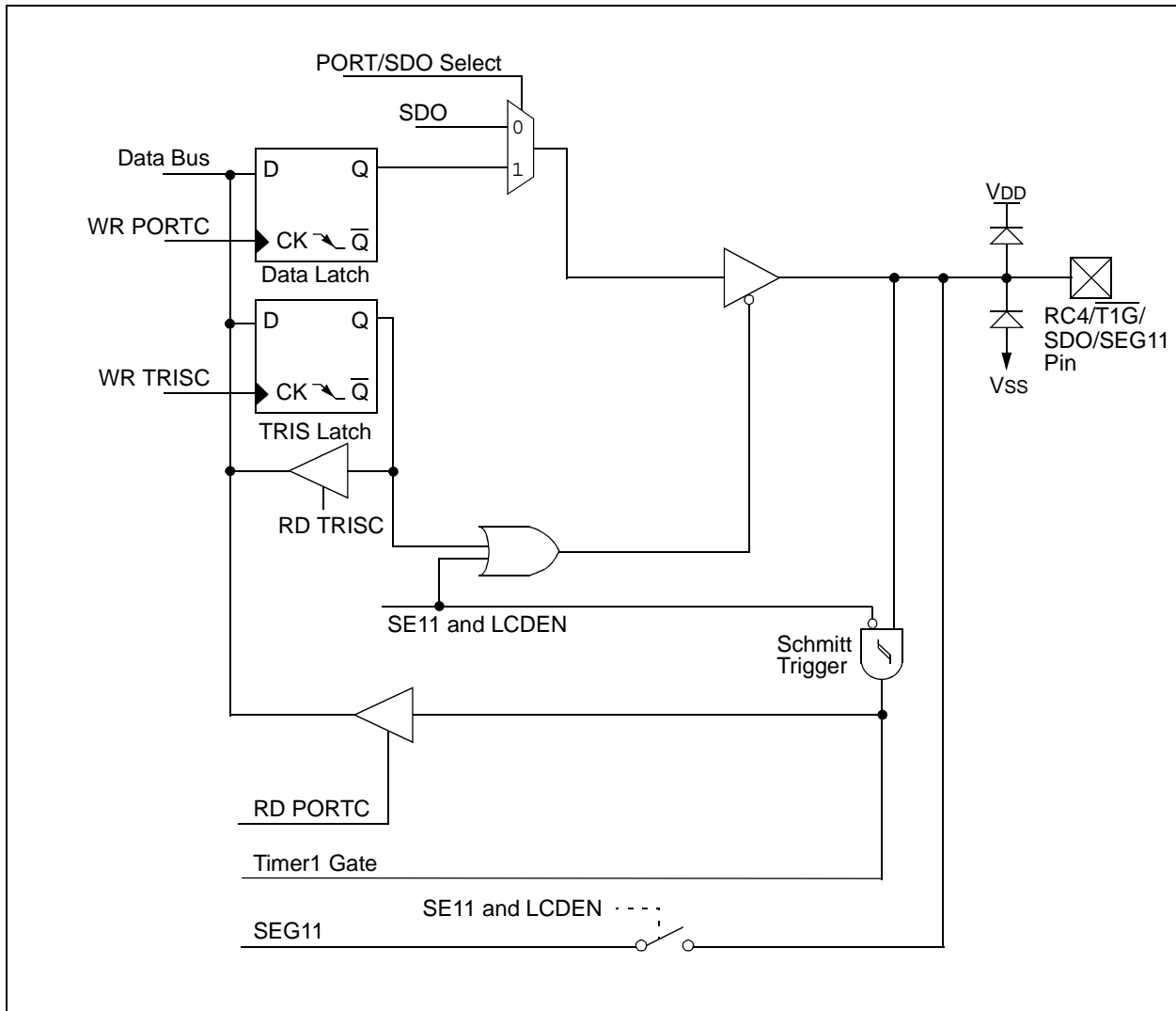

PIC16F917/916/914/913

3.4.1.6 RC5/T1CKI/CCP1/SEG10

Figure 3-19 shows the diagram for this pin. The RC5/T1CKI/CCP1/SEG10 pin is configurable to function as one of the following:

- a general purpose I/O
- a TMR1 clock input
- a Capture input, Compare output or PWM output
- an analog output for the LCD

FIGURE 3-19: BLOCK DIAGRAM OF RC5/T1CKI/CCP1/SEG10

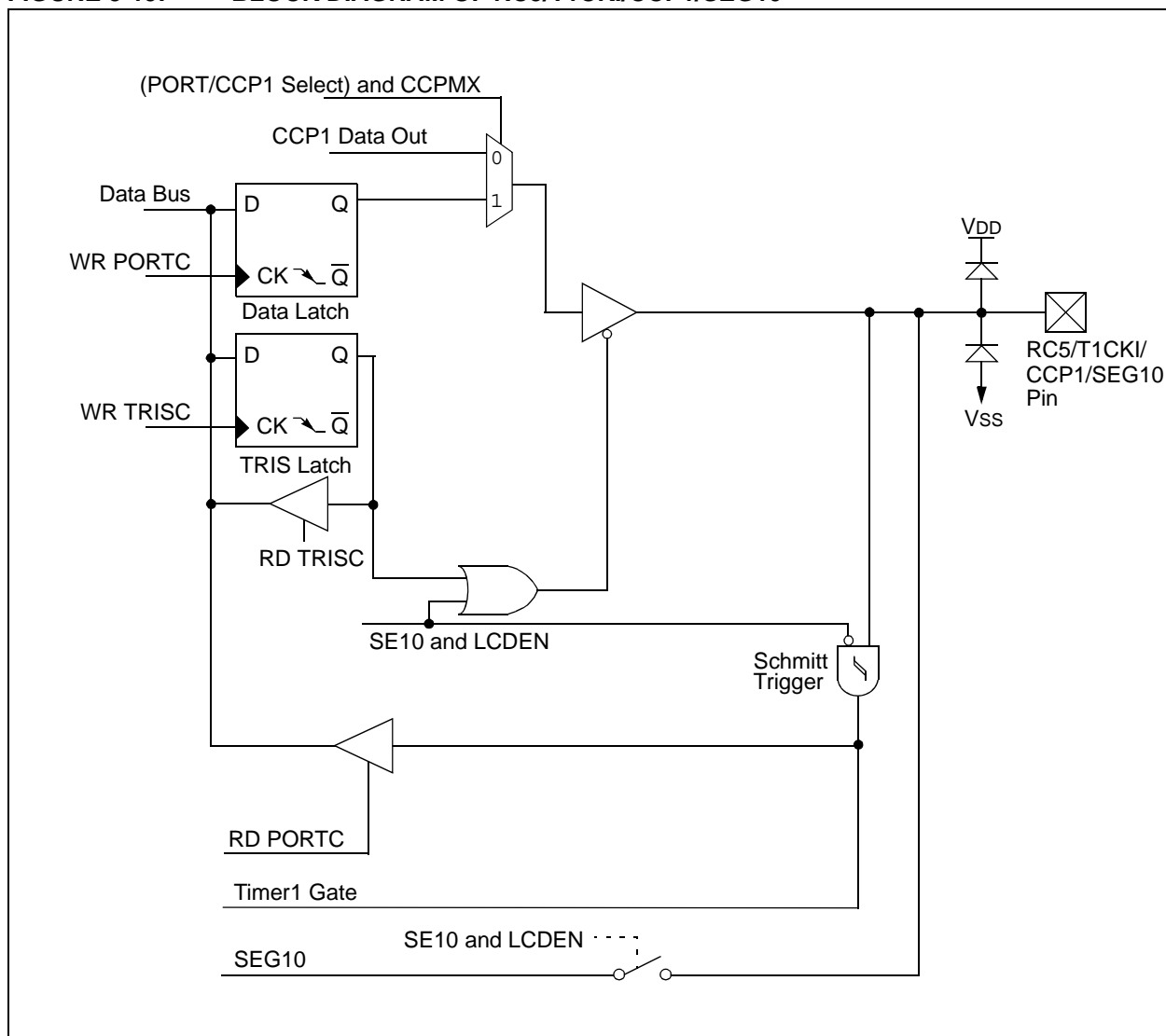

3.4.1.7 RC6/TX/CK/SCK/SCL/SEG9

Figure 3-20 shows the diagram for this pin. The RC6/TX/CK/SCK/SCL/SEG9 pin is configurable to function as one of the following:

- a general purpose I/O
- an asynchronous serial output
- a synchronous clock I/O
- a SPI clock I/O
- an I²C data I/O
- an analog output for the LCD

FIGURE 3-20: BLOCK DIAGRAM OF RC6/TX/CK/SCK/SCL/SEG9

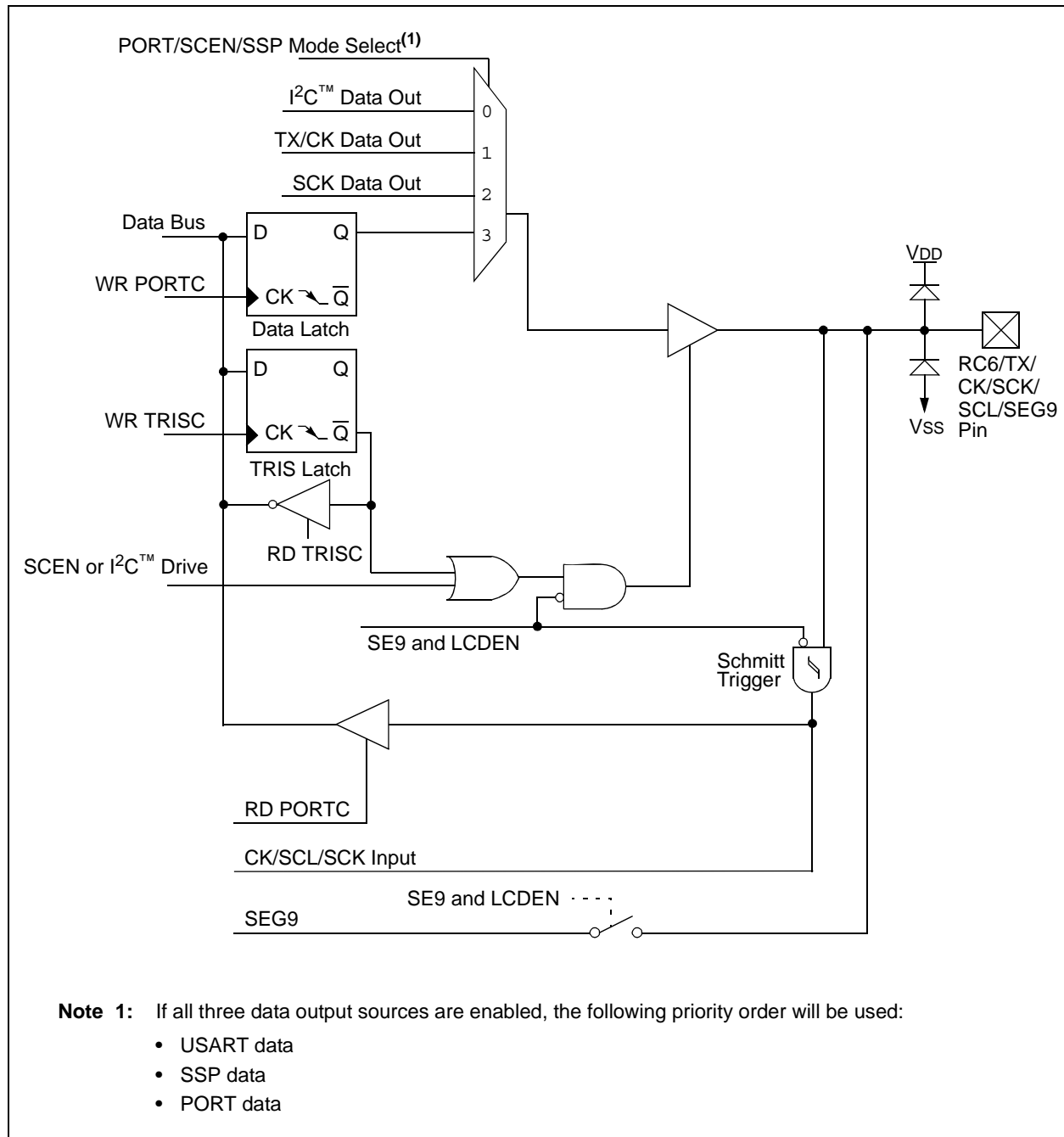

PIC16F917/916/914/913

3.4.1.8 RC7/RX/DT/SDI/SDA/SEG8

Figure 3-21 shows the diagram for this pin. The RC7/RX/DT/SDI/SDA/SEG8 pin is configurable to function as one of the following:

- a general purpose I/O
- an asynchronous serial input
- a synchronous serial data I/O
- a SPI data I/O
- an I²C data I/O
- an analog output for the LCD

FIGURE 3-21: BLOCK DIAGRAM OF RC7/RX/DT/SDI/SDA/SEG8

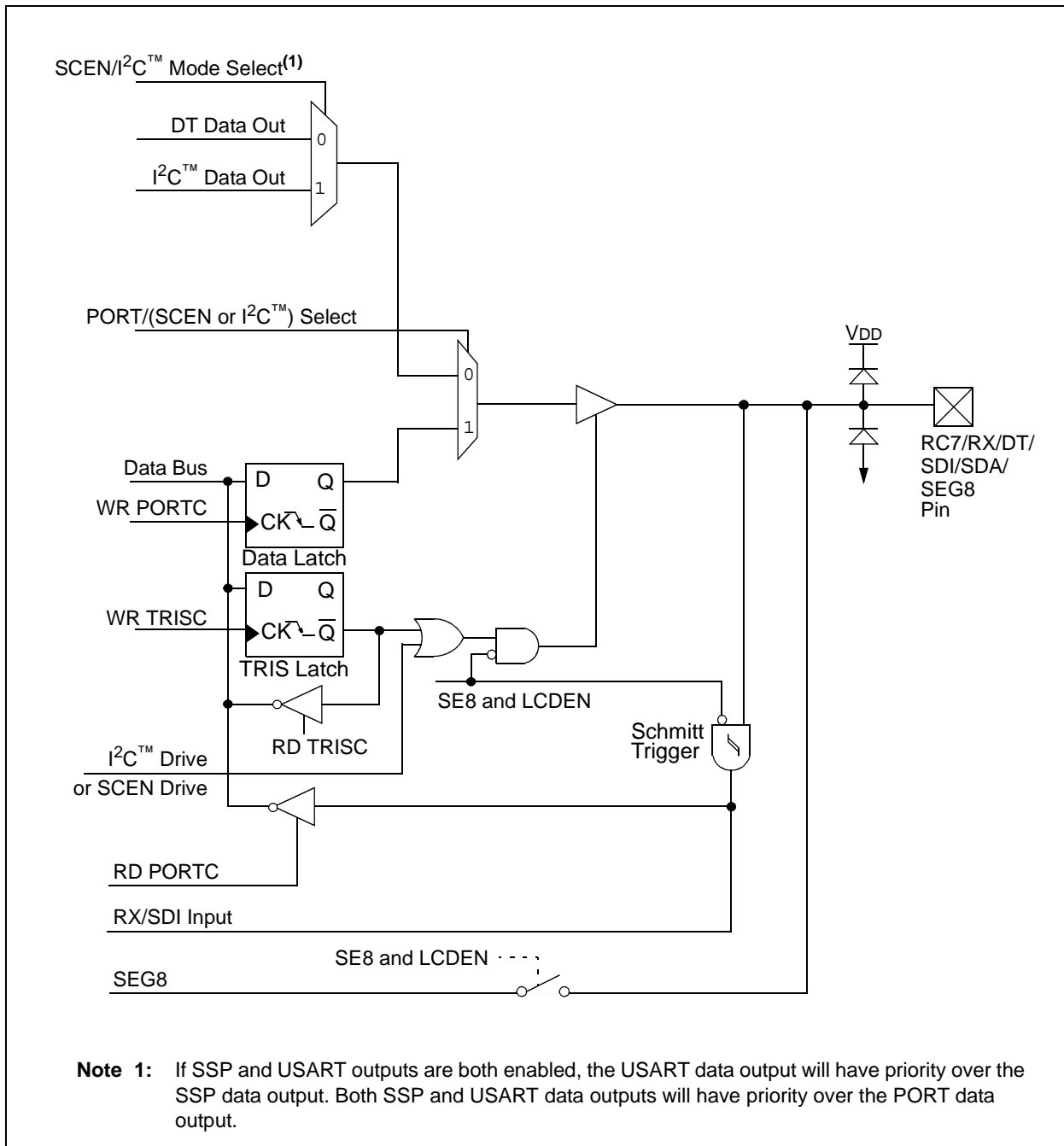

PIC16F917/916/914/913

TABLE 3-3: SUMMARY OF REGISTERS ASSOCIATED WITH PORTC

Address	Name	Bit 7	Bit 6	Bit 5	Bit 4	Bit 3	Bit 2	Bit 1	Bit 0	Value on: POR, BOR	Value on all other Resets
07h	PORTC	RC7	RC6	RC5	RC4	RC3	RC2	RC1	RC0	xxxx xxxx	uuuu uuuu
10h	T1CON	T1GINV	T1GE	T1CKPS1	T1CKPS0	T1OSCEN	T1SYNC	TMR1CS	TMR1ON	0000 0000	uuuu uuuu
14h	SSPCON	WCOL	SSPOV	SSPEN	CKP	SSPM3	SSPM2	SSPM1	SSPM0	0000 0000	0000 0000
17h	CCP1CON	—	—	CCP1X	CCP1Y	CCP1M3	CCP1M2	CCP1M1	CCP1M0	--00 0000	--00 0000
18h	RCSTA	SPEN	RX9	SREN	CREN	ADDEN	FERR	OERR	RX9D	0000 000x	0000 000x
87h	TRISC	TRISC7	TRISC6	TRISC5	TRISC4	TRISC3	TRISC2	TRISC1	TRISC0	1111 1111	1111 1111
107h	LCDCON	LCDEN	SLPEN	WERR	VLCDEN	CS1	CS0	LMUX1	LMUX0	0001 0011	0001 0011
11Ch	LCDSE0 ⁽¹⁾	SE7	SE6	SE5	SE4	SE3	SE2	SE1	SE0	0000 0000	uuuu uuuu
11Dh	LCDSE1 ⁽¹⁾	SE15	SE14	SE13	SE12	SE11	SE10	SE9	SE8	0000 0000	uuuu uuuu

Legend: x = unknown, u = unchanged, - = unimplemented locations read as '0'. Shaded cells are not used by PORTC.

Note 1: This register is only initialized by a POR or BOR reset and is unchanged by other Resets.

PIC16F917/916/914/913

3.5 PORTD and TRISD Registers

PORTD is an 8-bit port with Schmitt Trigger input buffers. Each pin is individually configured as an input or output.

PORTD is only available on the PIC16F914 and PIC16F917.

Note: Analog lines that carry LCD signals (i.e., SEGx, COMy, where x and y are segment and common identifiers) are shown as direct connections to the device pins. The signals are outputs from the LCD module and may be tri-stated, depending on the configuration of the LCD module.

EXAMPLE 3-4: INITIALIZING PORTD

```
BCF STATUS,RP0 ;Bank 0
BCF STATUS,RP1 ;
CLRF PORTD ;Init PORTD
BSF STATUS,RP0 ;Bank 1
BCF STATUS,RP1 ;
MOVLW FFh ;Set RD<7:0> as inputs
MOVWF TRISD ;
BCF STATUS,RP0 ;Bank 0
BCF STATUS,RP1 ;
```

REGISTER 3-9: PORTD – PORTD REGISTER (ADDRESS: 08h)

R/W-x	R/W-x	R/W-x	R/W-x	R/W-x	R/W-x	R/W-x	R/W-x
RD7	RD6	RD5	RD4	RD3	RD2	RD1	RD0

bit 7

bit 0

bit 7-0 **RD<7:0>**: PORTD I/O Pin bits
 1 = Port pin is >VIH
 0 = Port pin is <VIL

Legend:
 R = Readable bit W = Writable bit U = Unimplemented bit, read as '0'
 - n = Value at POR '1' = Bit is set '0' = Bit is cleared x = Bit is unknown

REGISTER 3-10: TRISD – PORTD TRI-STATE REGISTER (ADDRESS: 88h)

R/W-1	R/W-1	R/W-1	R/W-1	R/W-1	R/W-1	R/W-1	R/W-1
TRISD7	TRISD6	TRISD5	TRISD4	TRISD3	TRISD2	TRISD1	TRISD0

bit 7

bit 0

bit 7-0 **TRISD<7:0>**: PORTD Tri-State Control bits
 1 = PORTD pin configured as an input (tri-stated)
 0 = PORTD pin configured as an output

Note: TRISD<7:6> always reads '1' in XT, HS and LP OSC modes.

Legend:
 R = Readable bit W = Writable bit U = Unimplemented bit, read as '0'
 - n = Value at POR '1' = Bit is set '0' = Bit is cleared x = Bit is unknown

3.5.1 PIN DESCRIPTIONS AND DIAGRAMS

Each PORTD pin is multiplexed with other functions. The pins and their combined functions are briefly described here. For specific information about individual functions such as the comparator or the A/D, refer to the appropriate section in this data sheet.

3.5.1.1 RD0/COM3

Figure 3-22 shows the diagram for this pin. The RD0/COM3 pin is configurable to function as one of the following:

- a general purpose I/O
- an analog input for the A/D

3.5.1.2 RD1

Figure 3-23 shows the diagram for this pin. The RD1 pin is configurable to function as one of the following:

- a general purpose I/O

3.5.1.3 RD2/CCP2

Figure 3-24 shows the diagram for this pin. The RD2/CCP2 pin is configurable to function as one of the following:

- a general purpose I/O
- a Capture input, Compare output or PWM output

3.5.1.4 RD3/SEG16

Figure 3-25 shows the diagram for this pin. The RD3/SEG16 pin is configurable to function as one of the following:

- a general purpose I/O
- an analog output for the LCD

3.5.1.5 RD4/SEG17

Figure 3-25 shows the diagram for this pin. The RD4/SEG17 pin is configurable to function as one of the following:

- a general purpose I/O
- an analog output for the LCD

3.5.1.6 RD5/SEG18

Figure 3-25 shows the diagram for this pin. The RD5/SEG18 pin is configurable to function as one of the following:

- a general purpose I/O
- an analog output for the LCD

3.5.1.7 RD6/SEG19

Figure 3-25 shows the diagram for this pin. The RD6/SEG19 pin is configurable to function as one of the following:

- a general purpose I/O
- an analog output for the LCD

3.5.1.8 RD7/SEG20

Figure 3-25 shows the diagram for this pin. The RD7/SEG20 pin is configurable to function as one of the following:

- a general purpose I/O
- an analog output for the LCD

PIC16F917/916/914/913

FIGURE 3-22: BLOCK DIAGRAM OF RD0/COM3

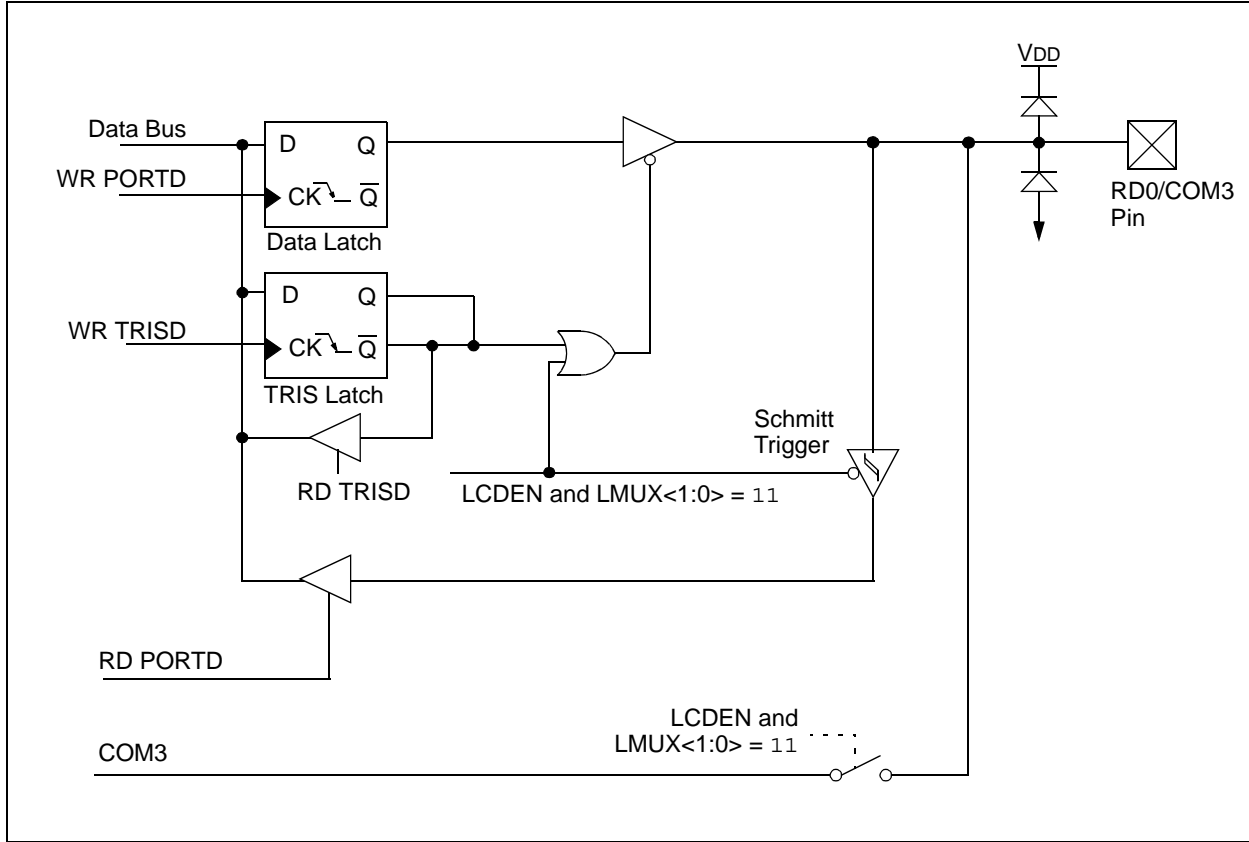

FIGURE 3-23: BLOCK DIAGRAM OF RD1

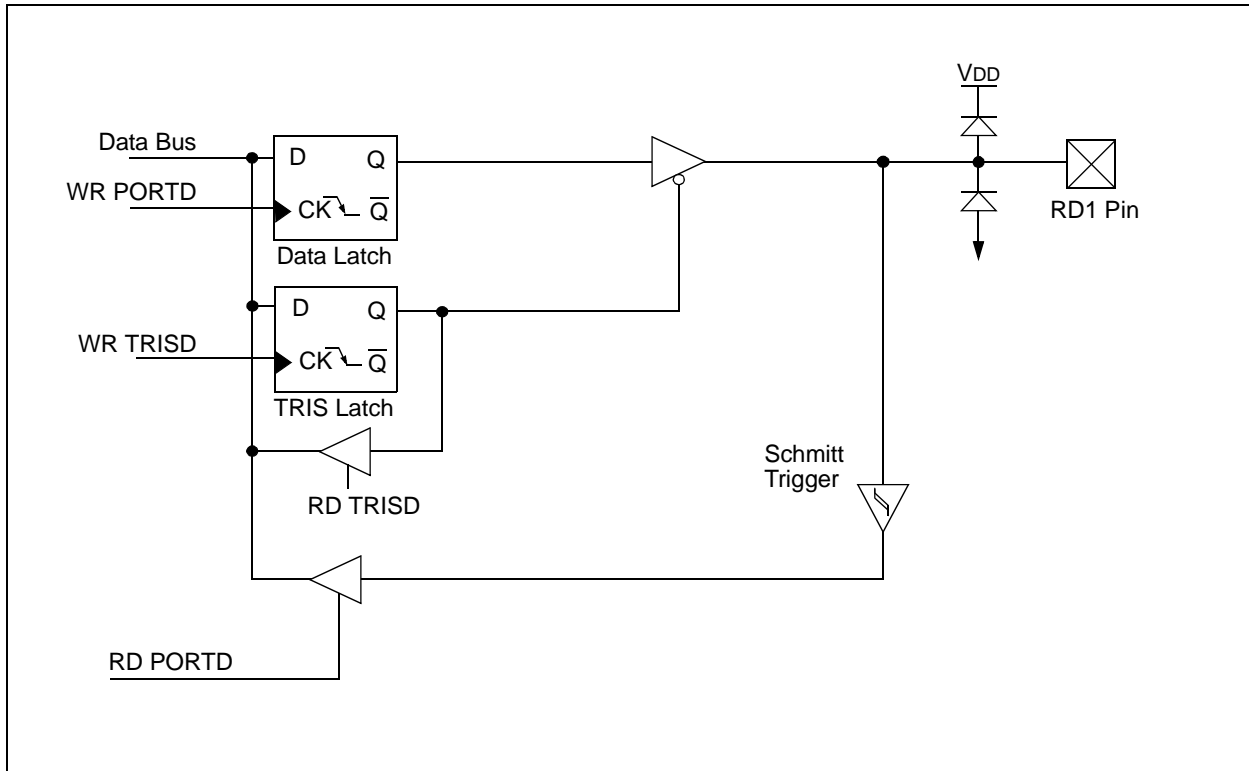

FIGURE 3-24: BLOCK DIAGRAM OF RD2/CCP2

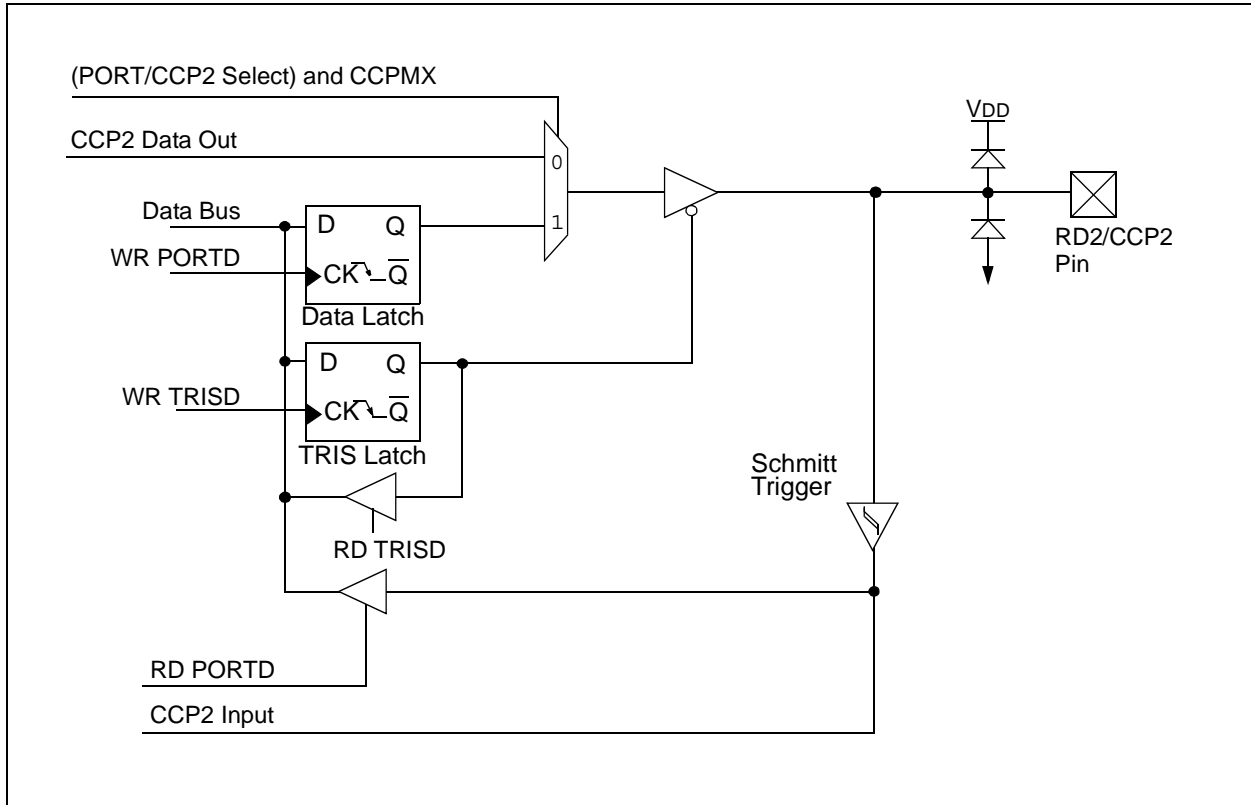
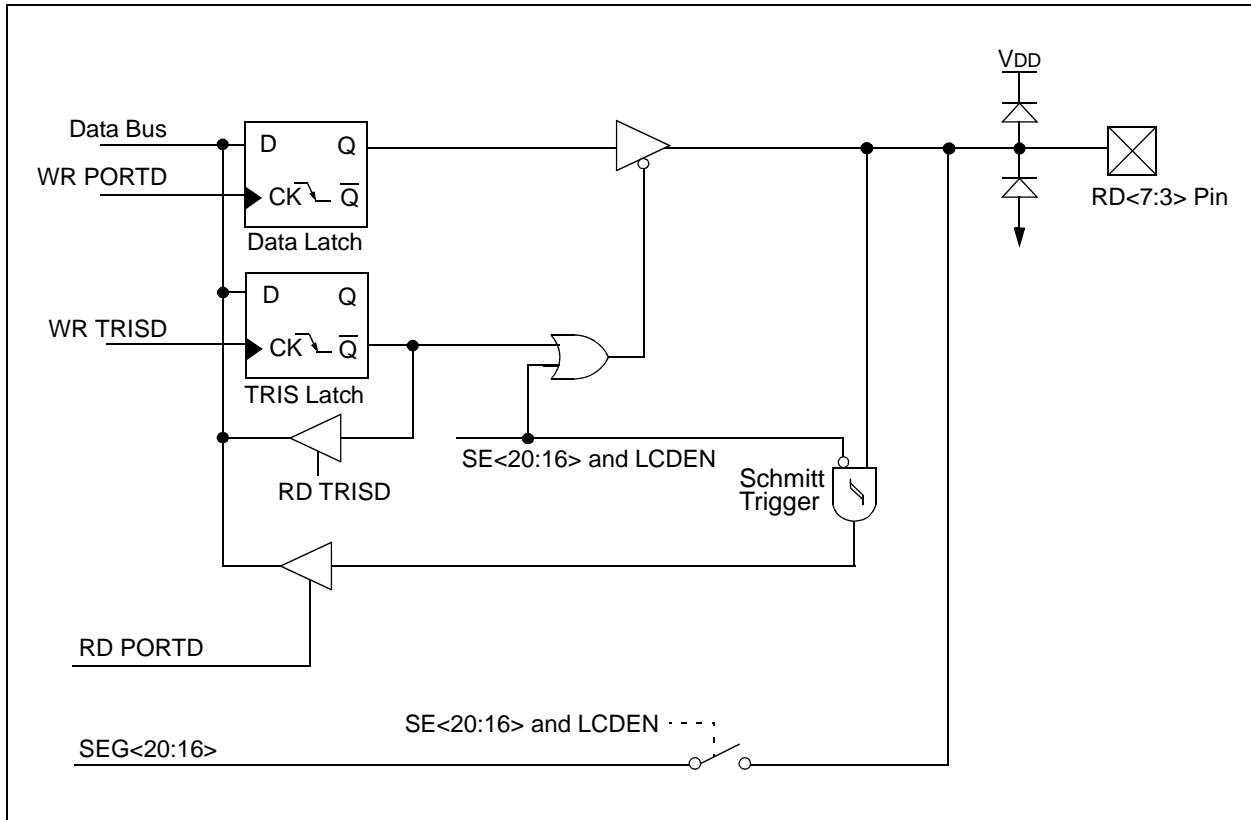

FIGURE 3-25: BLOCK DIAGRAM OF RD<7:3>



PIC16F917/916/914/913

TABLE 3-4: SUMMARY OF REGISTERS ASSOCIATED WITH PORTD

Address	Name	Bit 7	Bit 6	Bit 5	Bit 4	Bit 3	Bit 2	Bit 1	Bit 0	Value on: POR, BOR	Value on all other Resets
08h	PORTD	RD7	RD6	RD5	RD4	RD3	RD2	RD1	RD0	xxxx xxxx	uuuu uuuu
1Dh ⁽²⁾	CCP2CON	—	—	CCP2X	CCP2Y	CCP2M3	CCP2M2	CCP2M1	CCP2M0	--00 0000	--00 0000
88h	TRISD ⁽²⁾	TRISD7	TRISD6	TRISD5	TRISD4	TRISD3	TRISD2	TRISD1	TRISD0	1111 1111	1111 1111
107h	LCDCON	LCDEN	SLPEN	WERR	VLCDEN	CS1	CS0	LMUX1	LMUX0	0001 0011	0001 0011
11Eh	LCDSE2 ^(1,2)	SE23	SE22	SE21	SE20	SE19	SE18	SE17	SE16	0000 0000	uuuu uuuu

Legend: x = unknown, u = unchanged, - = unimplemented locations read as '0'. Shaded cells are not used by PORTC.

Note 1: This register is only initialized by a POR or BOR reset and is unchanged by other Resets.

Note 2: PIC16F914/917 only.

3.6 PORTE and TRISE Registers

PORTE is a 4-bit port with Schmitt Trigger input buffers. RE<2:0> are individually configured as inputs or outputs. RE3 is only available as an input if MCLRE is '0' in Configuration Word (Register 16-1).

RE<2:0> are only available on the PIC16F914 and PIC16F917.

Note: Analog lines that carry LCD signals (i.e., SEGx, where x are segment identifiers) are shown as direct connections to the device pins. The signals are outputs from the LCD module and may be tri-stated, depending on the configuration of the LCD module.

EXAMPLE 3-5: INITIALIZING PORTE

```
BCF STATUS,RP0 ;Bank 0
BCF STATUS,RP1 ;
CLRF PORTE ;Init PORTE
BSF STATUS,RP0 ;Bank 1
BCF STATUS,RP1 ;
MOVLW 0Fh ;Set RE<3:0> as inputs
MOVWF TRISE ;
CLRF ANSEL ;Make RE<2:0> as I/O's
BCF STATUS,RP0 ;Bank 0
BCF STATUS,RP1 ;
```

REGISTER 3-11: PORTE – PORTE REGISTER (ADDRESS: 09h)

U-0	U-0	U-0	U-0	R/W-x	R/W-x	R/W-x	R/W-x
—	—	—	—	RE3	RE2	RE1	RE0
bit 7				bit 0			

bit 7-4 **Unimplemented:** Read as '0'

bit 3-0 **RE<3:0>:** PORTE I/O Pin bits

1 = Port pin is >VIH

0 = Port pin is <VIL

Legend:

R = Readable bit W = Writable bit U = Unimplemented bit, read as '0'
 - n = Value at POR '1' = Bit is set '0' = Bit is cleared x = Bit is unknown

REGISTER 3-12: TRISE – PORTE TRI-STATE REGISTER (ADDRESS: 89h)

U-0	U-0	U-0	U-0	R-1	R/W-1	R/W-1	R/W-1
—	—	—	—	TRISE3	TRISE2	TRISE1	TRISE0
bit 7				bit 0			

bit 7-4 **Unimplemented:** Read as '0'

bit 3 **TRISE3:** Data Direction bit. RE3 is always an input, so this bit always reads as a '1'

bit 2-0 **TRISE<2:0>:** Data Direction bits

Legend:

R = Readable bit W = Writable bit U = Unimplemented bit, read as '0'
 - n = Value at POR '1' = Bit is set '0' = Bit is cleared x = Bit is unknown

PIC16F917/916/914/913

3.6.1 PIN DESCRIPTIONS AND DIAGRAMS

Each PORTE pin is multiplexed with other functions. The pins and their combined functions are briefly described here. For specific information about individual functions such as the comparator or the A/D, refer to the appropriate section in this data sheet.

3.6.1.1 RE0/AN5/SEG21

Figure 3-26 shows the diagram for this pin. The RE0/AN5/SEG21 pin is configurable to function as one of the following:

- a general purpose I/O
- an analog input for the A/D
- an analog output for the LCD

3.6.1.2 RE1/AN6/SEG22

Figure 3-26 shows the diagram for this pin. The RE1/AN6/SEG22 pin is configurable to function as one of the following:

- a general purpose I/O
- an analog input for the A/D
- an analog output for the LCD

3.6.1.3 RE2/AN7/SEG23

Figure 3-26 shows the diagram for this pin. The RE2/AN7/SEG23 pin is configurable to function as one of the following:

- a general purpose I/O
- an analog input for the A/D
- an analog output for the LCD

3.6.1.4 RE3/MCLR/VPP

Figure 3-27 shows the diagram for this pin. The RE3/MCLR/VPP pin is configurable to function as one of the following:

- a digital input only
- as Master Clear Reset with weak pull-up
- a programming voltage reference input

FIGURE 3-26: BLOCK DIAGRAM OF RE<2:0>

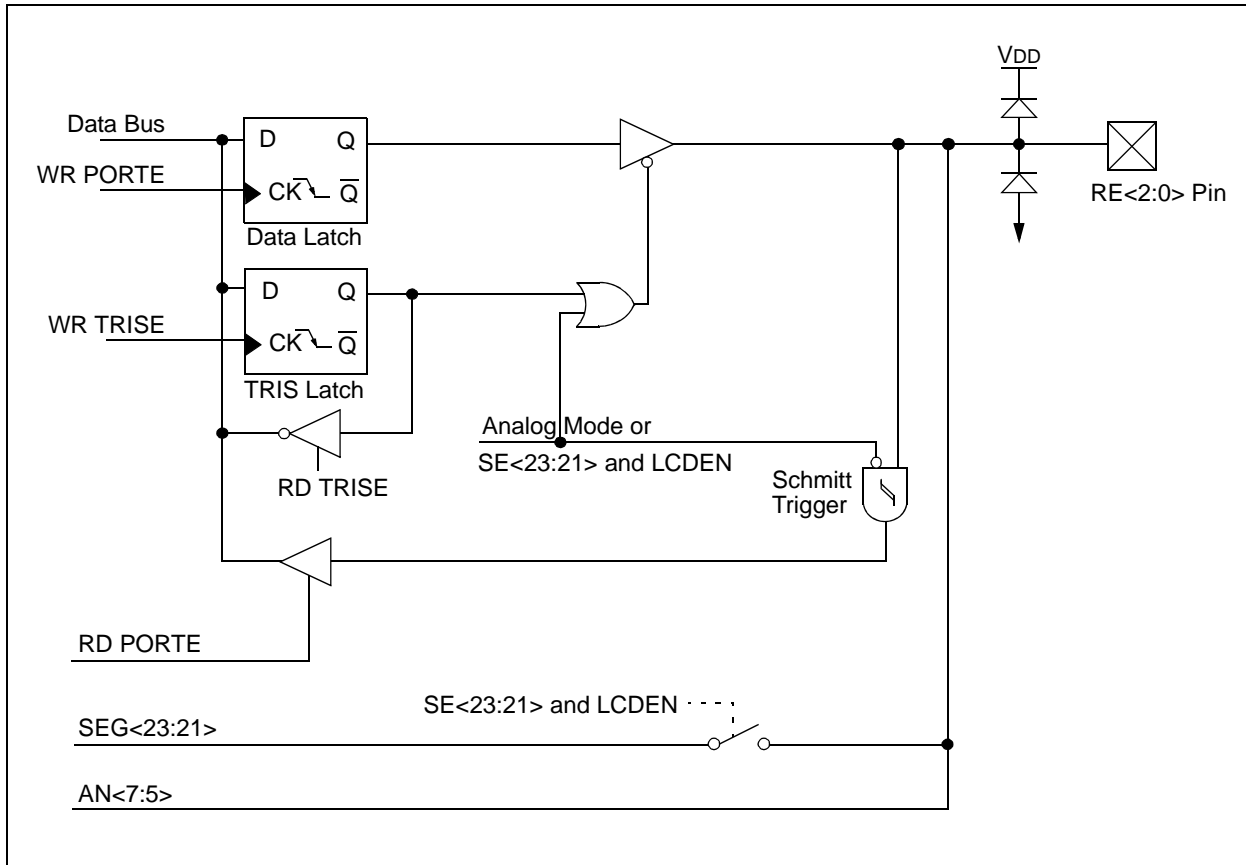

PIC16F917/916/914/913

FIGURE 3-27: BLOCK DIAGRAM OF RE3/MCLR/VPP

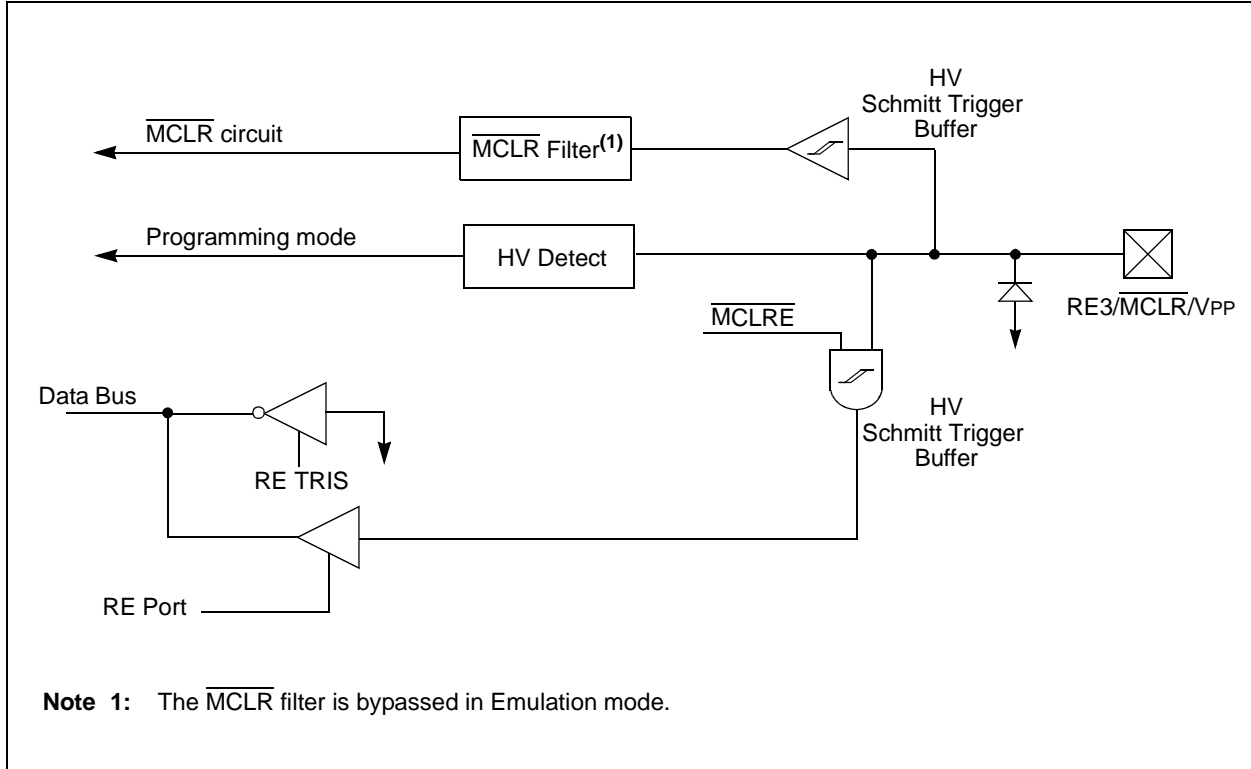

TABLE 3-5: SUMMARY OF REGISTERS ASSOCIATED WITH PORTE

Address	Name	Bit 7	Bit 6	Bit 5	Bit 4	Bit 3	Bit 2	Bit 1	Bit 0	Value on: POR, BOR	Value on all other Resets
09h	PORTE	—	—	—	—	RE3	RE2	RE1	RE0	---- xxxx	---- uuuu
1Fh	ADCON0	ADFM	VCFG1	VCFG0	CHS2	CHS1	CHS0	GO/DONE	ADON	0000 0000	0000 0000
89h	TRISE	—	—	—	—	TRISE3 ⁽³⁾	TRISE2 ⁽²⁾	TRISE1 ⁽²⁾	TRISE0 ⁽²⁾	---- 1111	---- 1111
91h	ANSEL	ANS7	ANS6	ANS5	ANS4	ANS3	ANS2	ANS1	ANS0	1111 1111	1111 1111
107h	LCDCON	LCDEN	SLPEN	WERR	VLCDEN	CS1	CS0	LMUX1	LMUX0	0001 0011	0001 0011
11Eh	LCDSE2 ^(1,2)	SE23	SE22	SE21	SE20	SE19	SE18	SE17	SE16	0000 0000	uuuu uuuu

Legend: x = unknown, u = unchanged, - = unimplemented locations read as '0'. Shaded cells are not used by PORTC.

Note 1: This register is only initialized by a POR or BOR reset and is unchanged by other Resets.

2: PIC16F914/917 only.

3: Bit is read-only; TRISE = 1 always.

PIC16F917/916/914/913

NOTES:

4.0 CLOCK SOURCES

4.1 Overview

The PIC16F917/916/914/913 has a wide variety of clock sources and selection features to allow it to be used in a wide range of applications while maximizing performance and minimizing power consumption. Figure 4-1 illustrates a block diagram of the PIC16F917/916/914/913 clock sources.

Clock sources can be configured from external oscillators, quartz crystal resonators, ceramic resonators, and Resistor-Capacitor (RC) circuits. In addition, the system clock source can be configured from one of two internal oscillators, with a choice of speeds selectable via software. Additional clock features include:

- Selectable system clock source between external or internal via software.
- Two-Speed Clock Start-up mode, which minimizes latency between external oscillator start-up and code execution.
- Fail-Safe Clock Monitor (FSCM) designed to detect a failure of the external clock source (LP, XT, HS, EC or RC modes) and switch to the Internal Oscillator.

The PIC16F917/916/914/913 can be configured in one of eight clock modes.

1. EC – External clock with I/O on RA6.
2. LP – Low-gain Crystal or Ceramic Resonator Oscillator mode.
3. XT – Medium-gain Crystal or Ceramic Resonator Oscillator mode.
4. HS – High-gain Crystal or Ceramic Resonator mode.
5. RC – External Resistor-Capacitor (RC) with FOSC/4 output on RA6.
6. RCIO – External Resistor-Capacitor with I/O on RA6.
7. INTOSC – Internal oscillator with FOSC/4 output on RA6 and I/O on RA7.
8. INTOSCIO – Internal oscillator with I/O on RA6 and RA7.

Clock source modes are configured by the FOSC<2:0> bits in the Configuration Word register (see **Section 16.0 “Special Features of the CPU”**). The internal clock can be generated by two oscillators. The HFINTOSC is a high-frequency calibrated oscillator. The LFINTOSC is a low-frequency uncalibrated oscillator.

FIGURE 4-1: PIC16F917/916/914/913 SYSTEM CLOCK BLOCK DIAGRAM

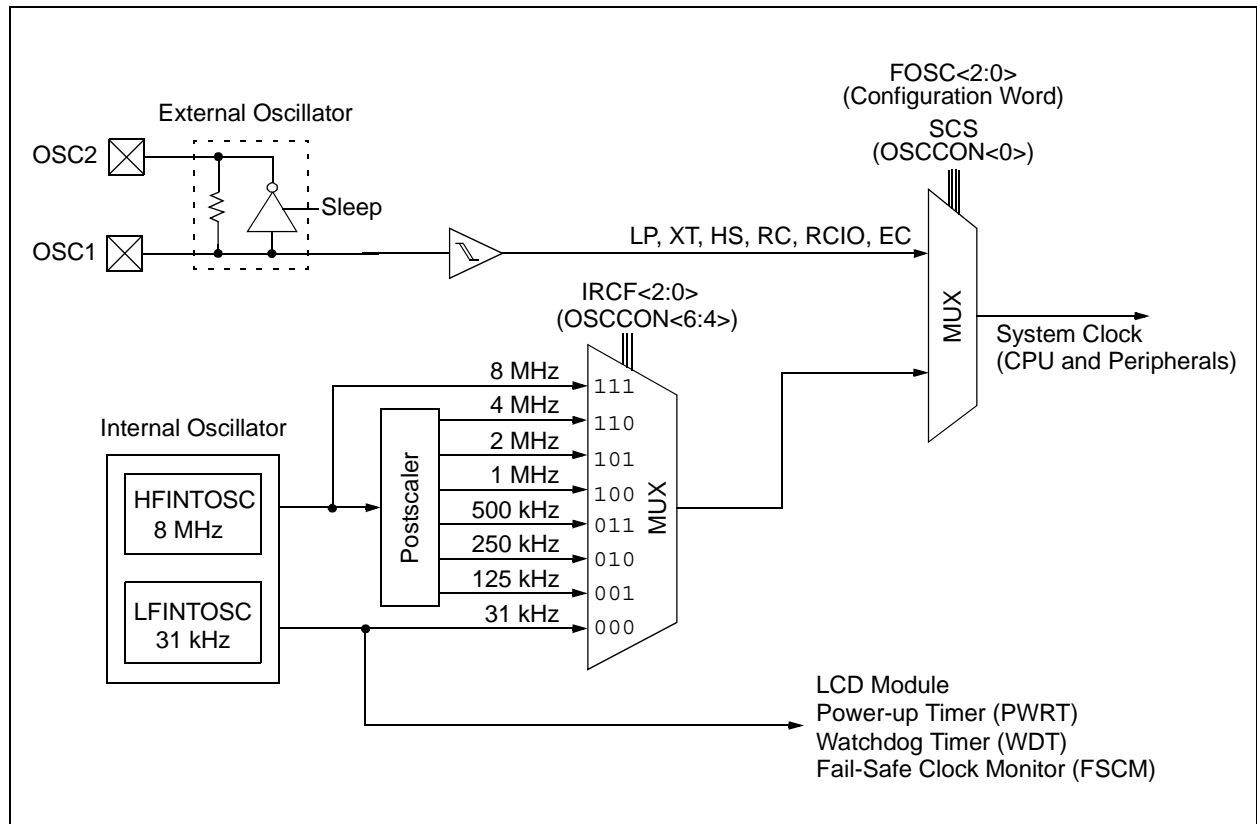

PIC16F917/916/914/913

REGISTER 4-1: OSCCON – OSCILLATOR CONTROL REGISTER (ADDRESS: 8Fh)

U-0	R/W-1	R/W-1	R/W-0	R-q	R-0	R-0	R/W-0
—	IRCF2	IRCF1	IRCF0	OSTS ⁽¹⁾	HTS	LTS	SCS
bit 7							bit 0

- bit 7 **Unimplemented:** Read as '0'
- bit 6-4 **IRCF<2:0>:** Internal Oscillator Frequency Select bits
- 000 = 31 kHz
 - 001 = 125 kHz
 - 010 = 250 kHz
 - 011 = 500 kHz
 - 100 = 1 MHz
 - 101 = 2 MHz
 - 110 = 4 MHz
 - 111 = 8 MHz
- bit 3 **OSTS:** Oscillator Start-up Time-out Status bit
- 1 = Device is running from the external system clock defined by FOSC<2:0>
 - 0 = Device is running from the internal system clock (HFINTOSC or LFINTOSC)
- bit 2 **HTS:** HFINTOSC (High Frequency – 8 MHz to 125 kHz) Status bit
- 1 = HFINTOSC is stable
 - 0 = HFINTOSC is not stable
- bit 1 **LTS:** LFINTOSC (Low Frequency – 31 kHz) Stable bit
- 1 = LFINTOSC is stable
 - 0 = LFINTOSC is not stable
- bit 0 **SCS:** System Clock Select bit
- 1 = Internal oscillator is used for system clock
 - 0 = Clock source defined by FOSC<2:0>

Note 1: The value of the OSTS bit on device power-up is dependent on the value of the Configuration Word (CONFIG) of the device. The value of the OSTS bit will be '0' on a device Power-on Reset (POR) or any automatic clock switch, which may occur from Two-Speed Start-up or Fail-Safe Clock Monitor, if the following conditions are true:

OSTS = 0 if:
 FOSC<2:0> = 000 (LP) or 001 (XT) or 010 (HS)
 and
 IESO = 1 or FSCM = 1

(IESO will be enabled automatically if FSCM is enabled)

If any of the above conditions are not met, the value of the OSTS bit will be '1' on a device POR. See **Section 4.6 “Two-Speed Clock Start-up Mode”** and **Section 4.7 “Fail-Safe Clock Monitor”** for more details.

Legend:

R = Readable bit	W = Writable bit	U = Unimplemented bit, read as '0'
- n = Value at POR	'1' = Bit is set	'0' = Bit is cleared x = Bit is unknown
q = value depends on condition		

4.2 Clock Source Modes

Clock source modes can be classified as external or internal.

- External clock modes rely on external circuitry for the clock source. Examples are oscillator modules (EC mode), quartz crystal resonators or ceramic resonators (LP, XT and HS modes), and Resistor-Capacitor (RC mode) circuits.
- Internal clock sources are contained internally within the PIC16F917/916/914/913. The PIC16F917/916/914/913 has two internal oscillators: the 8 MHz High-Frequency Internal Oscillator (HFINTOSC) and 31 kHz Low-Frequency Internal Oscillator (LFINTOSC).

The system clock can be selected between external or internal clock sources via the System Clock Selection (SCS) bit (see **Section 4.5 “Clock Switching”**).

4.3 External Clock Modes

4.3.1 OSCILLATOR START-UP TIMER (OST)

If the PIC16F917/916/914/913 is configured for LP, XT or HS modes, the Oscillator Start-up Timer (OST) counts 1024 oscillations from the OSC1 pin, following a Power-on Reset (POR), and the Power-up Timer (PWRT) has expired (if configured), or a wake-up from Sleep. During this time, the program counter does not increment and program execution is suspended. The OST ensures that the oscillator circuit, using a quartz crystal resonator or ceramic resonator, has started and is providing a stable system clock to the PIC16F917/916/914/913. When switching between clock sources a delay is required to allow the new clock to stabilize. These oscillator delays are shown in Table 4-1.

4.3.1.1 Special Case

An exception to this is when the device is put to Sleep while the following conditions are true:

- LP is the selected primary oscillator mode.
- T1OSCEN = 1 (Timer1 oscillator is enabled).
- SCS = 0 (oscillator mode is defined by FOSC<2:0>).
- OSTS = 1 (device is running from primary system clock).

For this case, the OST is not necessary after a wake-up from Sleep, since Timer1 continues to run during Sleep and uses the same LP oscillator circuit as its clock source. For these devices, this case is typically seen when the LCD module is running during Sleep.

In applications where the OSCTUNE register is used to shift the FINTOSC frequency, the application should not expect the FINTOSC frequency to stabilize immediately. In this case, the frequency may shift gradually toward the new value. The time for this frequency shift is less than eight cycles of the base frequency.

<p>Note: When the OST is invoked, the WDOG is held in Reset, because the WDOG ripple counter is used by the OST to perform the oscillator delay count. When the OST count has expired, the WDOG will begin counting (if enabled).</p>
--

Table 4-1 shows examples where the oscillator delay is invoked.

In order to minimize latency between external oscillator start-up and code execution, the Two-Speed Clock Start-up mode can be selected (see **Section 4.6 “Two-Speed Clock Start-up Mode”**).

PIC16F917/916/914/913

TABLE 4-1: OSCILLATOR DELAY EXAMPLES

System Clock Source	Frequency	Switching From	Oscillator Delay (T _{OST})	Comments
LFIOSC	31 kHz	Sleep	10 μs internal delay	Following a wake-up from Sleep mode or POR, an internal delay is invoked to allow the memory bias to stabilize before program execution can begin.
HFIOSC	125 kHz-8 MHz	Sleep	10 μs internal delay	Following a wake-up from Sleep mode or POR, an internal delay is invoked to allow the memory bias to stabilize before program execution can begin.
XT or HS	4-20 MHz	INTOSC or Sleep	1024 clock cycles	Following a change from INTOSC, an OST of 1024 cycles must occur.
LP	32 kHz	INTOSC or Sleep	1024 clock cycles	Following a change from INTOSC, an OST of 1024 cycles must occur. See Section 4.3.1.1 “Special Case” for special case conditions.
LP with T1OSC enabled	32 kHz	Sleep	10 μs internal delay	Following a wake-up from Sleep mode, an internal delay is invoked to allow the memory bias to stabilize before program execution can begin. See Section 4.3.1.1 “Special Case” for details about this special case.
EC, RC	0-20 MHz	Sleep	10 μs internal delay	Following a wake-up from Sleep mode or POR, an internal delay is invoked to allow the memory bias to stabilize before program execution can begin.
EC, RC	0-20 MHz	LFIOSC	10 μs internal delay	Following a switch from a LFIOSC or POR, an internal delay is invoked to allow the memory bias to stabilize before program execution can begin.

4.3.2 EC MODE

The External Clock (EC) mode allows an externally generated logic level as the system clock source. When operating in this mode, an external clock source is connected to the OSC1 pin and the RA6 pin is available for general purpose I/O. Figure 4-2 shows the pin connections for EC mode.

The Oscillator Start-up Timer (OST) is disabled when EC mode is selected. Therefore, there is no delay in operation after a Power-on Reset (POR) or wake-up from Sleep. Because the PIC16F917/916/914/913 design is fully static, stopping the external clock input will have the effect of halting the device while leaving all data intact. Upon restarting the external clock, the device will resume operation as if no time had elapsed.

FIGURE 4-2: EXTERNAL CLOCK (EC) MODE OPERATION

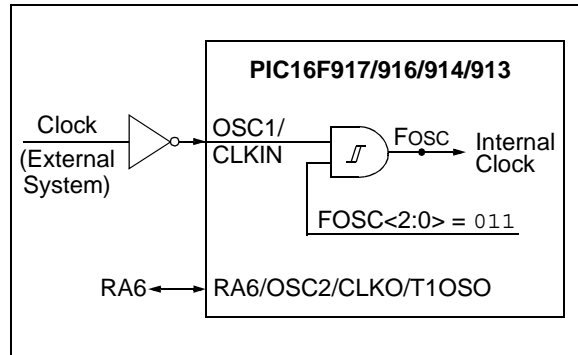

4.3.3 LP, XT, HS MODES

The LP, XT and HS modes support the use of quartz crystal resonators or ceramic resonators connected to the OSC1 and OSC2 pins (Figures 4-3 and 4-4). The mode selects a low, medium or high gain setting of the internal inverter-amplifier to support various resonator types and speed.

LP Oscillator mode selects the lowest gain setting of the internal inverter-amplifier. LP mode current consumption is the least of the three modes. This mode is best suited to drive resonators with a low drive level specification, for example, tuning fork type crystals.

Note: In the past, the sources for the LP oscillator and Timer1 oscillator have been separate circuits. In this family of devices, the LP oscillator and Timer1 oscillator use the same oscillator circuitry. When using a device configured for the LP oscillator and with T1OSCEN = 1, the source of the clock for each function comes from the same oscillator block.

XT Oscillator mode selects the intermediate gain setting of the internal inverter-amplifier. XT mode current consumption is the medium of the three modes. This mode is best suited to drive resonators with a medium drive level specification, for example, low-frequency/AT-cut quartz crystal resonators.

HS Oscillator mode selects the highest gain setting of the internal inverter-amplifier. HS mode current consumption is the highest of the three modes. This mode is best suited for resonators that require a high drive setting, for example, high-frequency/AT-cut quartz crystal resonators or ceramic resonators.

Figures 4-3 and 4-4 show typical circuits for quartz crystal and ceramic resonators, respectively.

PIC16F917/916/914/913

FIGURE 4-3: QUARTZ CRYSTAL OPERATION (LP, XT OR HS MODE)

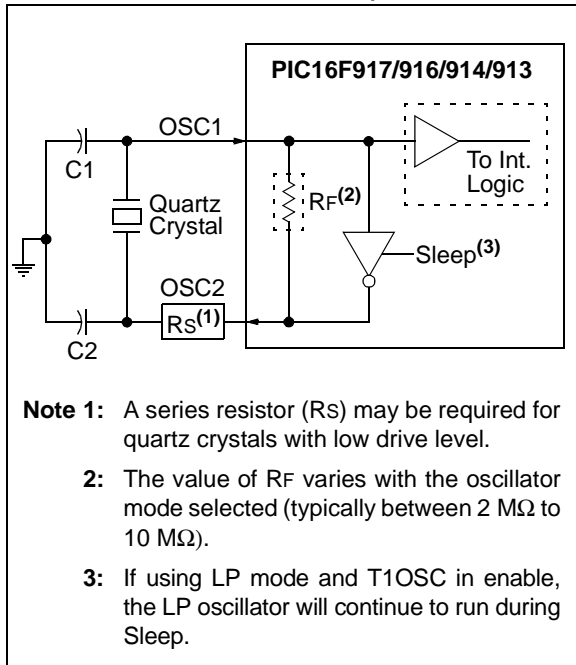

Note 1: Quartz crystal characteristics vary according to type, package and manufacturer. The user should consult the manufacturer data sheets for specifications and recommended application.

2: Always verify oscillator performance over the V_{DD} and temperature range that is expected for the application.

FIGURE 4-4: CERAMIC RESONATOR OPERATION (XT OR HS MODE)

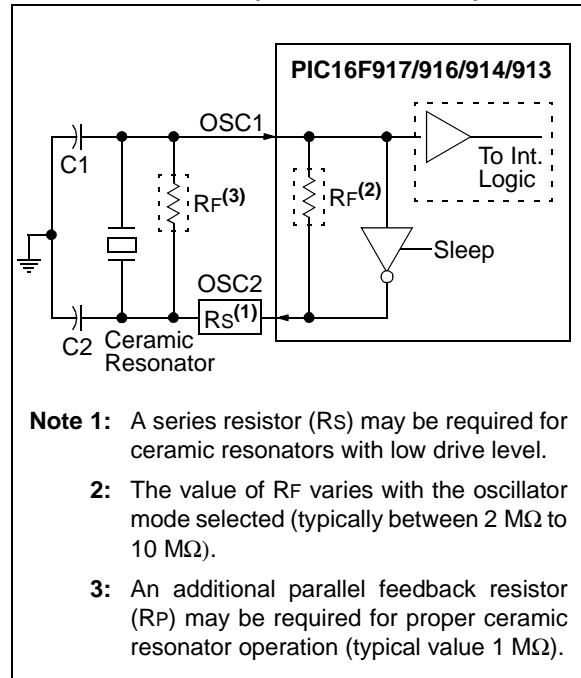

4.3.4 EXTERNAL RC MODES

The External Resistor-Capacitor (RC) modes support the use of an external RC circuit. This allows the designer maximum flexibility in frequency choice while keeping costs to a minimum when clock accuracy is not required. There are two modes, RC and RCIO.

In RC mode, the RC circuit connects to the OSC1 pin. The OSC2/CLKO pin outputs the RC oscillator frequency divided by 4. This signal may be used to provide a clock for external circuitry, synchronization, calibration, test or other application requirements. Figure 4-5 shows the RC mode connections.

FIGURE 4-5: RC MODE

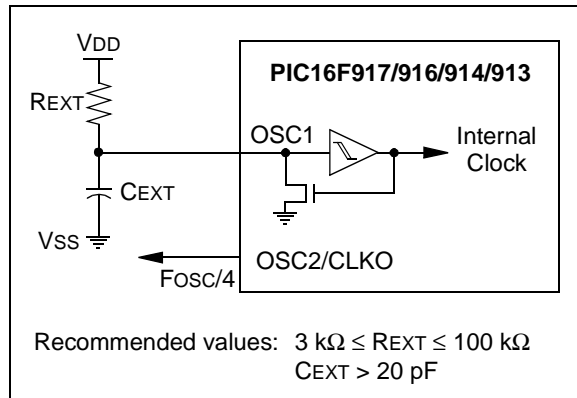

In RCIO mode, the RC circuit is connected to the OSC1 pin. The OSC2 pin becomes an additional general purpose I/O pin. The I/O pin becomes bit 4 of PORTA (RA4). Figure 4-6 shows the RCIO mode connections.

FIGURE 4-6: RCIO MODE

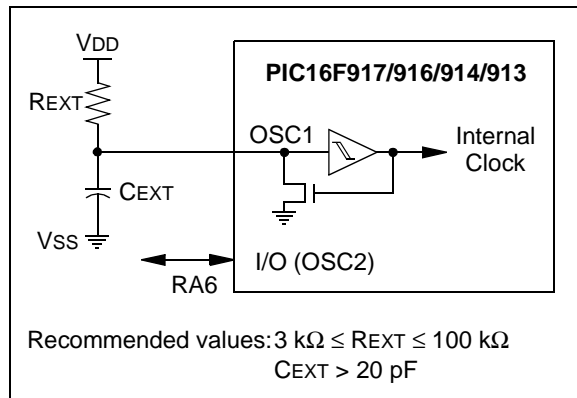

The RC oscillator frequency is a function of the supply voltage, the resistor (R_{EXT}) and capacitor (C_{EXT}) values and the operating temperature. In addition to this, the oscillator frequency will vary from unit to unit due to normal threshold voltage. Furthermore, the difference in lead frame capacitance between package types will also affect the oscillation frequency or for low C_{EXT} values. The user also needs to take into account variation due to tolerance of external RC components used.

4.4 Internal Clock Modes

The PIC16F917/916/914/913 has two independent, internal oscillators that can be configured or selected as the system clock source.

1. The **HFINTOSC** (High-Frequency Internal Oscillator) is factory calibrated and operates at 8 MHz. The frequency of the HFINTOSC can be user adjusted $\pm 12\%$ via software using the OSCTUNE register (Register 4-2).
2. The **LFINTOSC** (Low-Frequency Internal Oscillator) is uncalibrated and operates at approximately 31 kHz.

The system clock speed can be selected via software using the Internal Oscillator Frequency Select (IRCF) bits.

The system clock can be selected between external or internal clock sources via the System Clock Selection (SCS) bit (see **Section 4.5 "Clock Switching"**).

4.4.1 INTOSC AND INTOSCIO MODES

The INTOSC and INTOSCIO modes configure the internal oscillators as the system clock source when the device is programmed using the Oscillator Selection (FOSC) bits in the Configuration Word register (Register 16-1).

In **INTOSC** mode, the OSC1 pin is available for general purpose I/O. The OSC2/CLKO pin outputs the selected internal oscillator frequency divided by 4. The CLKO signal may be used to provide a clock for external circuitry, synchronization, calibration, test or other application requirements.

In **INTOSCIO** mode, the OSC1 and OSC2 pins are available for general purpose I/O.

4.4.2 HFINTOSC

The High-Frequency Internal Oscillator (HFINTOSC) is a factory calibrated 8 MHz internal clock source. The frequency of the HFINTOSC can be altered approximately $\pm 12\%$ via software using the OSCTUNE register (Register 4-2).

The output of the HFINTOSC connects to a postscaler and multiplexer (see Figure 4-1). One of seven frequencies can be selected via software using the IRCF bits (see **Section 4.4.4 "Frequency Select Bits (IRCF)"**).

The HFINTOSC is enabled by selecting any frequency between 8 MHz and 125 kHz ($IRCF \neq 000$) as the System Clock Source ($SCS = 1$), or when Two-Speed Start-up is enabled ($IESO = 1$ and $IRCF \neq 000$).

The HF Internal Oscillator (HTS) bit ($OSCCON<2>$) indicates whether the HFINTOSC is stable or not.

PIC16F917/916/914/913

4.4.2.1 OSCTUNE Register

The HFINTOSC is factory calibrated but can be adjusted in software by writing to the OSCTUNE register (Register 4-2).

The OSCTUNE register has a tuning range of $\pm 12\%$. The default value of the OSCTUNE register is '0'. The value is a 5-bit two's complement number. Due to process variation, the monotonicity and frequency step cannot be specified.

When the OSCTUNE register is modified, the HFINTOSC frequency will begin shifting to the new frequency. The HFINTOSC clock will stabilize within 1 ms. Code execution continues during this shift. There is no indication that the shift has occurred.

OSCTUNE does not affect the LFINTOSC frequency. Operation of features that depend on the LFINTOSC clock source frequency, such as the Power-up Timer (PWRT), Watchdog Timer (WDT), Fail-Safe Clock Monitor (FSCM) and peripherals, are *not* affected by the change in frequency.

REGISTER 4-2: OSCTUNE – OSCILLATOR TUNING RESISTOR (ADDRESS: 90h)

U-0	U-0	U-0	R/W-0	R/W-0	R/W-0	R/W-0	R/W-0	
—	—	—	TUN4	TUN3	TUN2	TUN1	TUN0	
bit 7								bit 0

bit 7-5 **Unimplemented:** Read as '0'

bit 4-0 **TUN<4:0>:** Frequency Tuning bits

01111 = Maximum frequency

01110 =

•

•

•

00001 =

00000 = Center frequency. Oscillator module is running at the calibrated frequency.

11111 =

•

•

•

10000 = Minimum frequency

Legend:

R = Readable bit

W = Writable bit

U = Unimplemented bit, read as '0'

- n = Value at POR

'1' = Bit is set

'0' = Bit is cleared

x = Bit is unknown

4.4.3 LFINTOSC

The Low-Frequency Internal Oscillator (LFINTOSC) is an uncalibrated (approximate) 31 kHz internal clock source.

The output of the LFINTOSC connects to a postscaler and multiplexer (see Figure 4-1). 31 kHz can be selected via software using the IRCF bits (see **Section 4.4.4 “Frequency Select Bits (IRCF)”**). The LFINTOSC is also the frequency for the Power-up Timer (PWRT), Watchdog Timer (WDT) and Fail-Safe Clock Monitor (FSCM).

The LFINTOSC is enabled by selecting 31 kHz (IRCF = 000) as the System Clock Source (SCS = 1), or when any of the following are enabled:

- Two-Speed Start-up (IESO = 1 and IRCF = 000)
- Power-up Timer (PWRT)
- Watchdog Timer (WDT)
- Fail-Safe Clock Monitor (FSCM)
- Selected as LCD module clock source

The LF Internal Oscillator (LTS) bit (OSCCON<1>) indicates whether the LFINTOSC is stable or not.

4.4.4 FREQUENCY SELECT BITS (IRCF)

The output of the 8 MHz HFINTOSC and 31 kHz LFINTOSC connect to a postscaler and multiplexer (see Figure 4-1). The Internal Oscillator Frequency select bits, IRCF<2:0> (OSCCON<6:4>), select the frequency output of the internal oscillators. One of eight frequencies can be selected via software:

- 8 MHz
- 4 MHz (Default after Reset)
- 2 MHz
- 1 MHz
- 500 kHz
- 250 kHz
- 125 kHz
- 31 kHz

Note: Following any Reset, the IRCF bits are set to '110' and the frequency selection is set to 4 MHz. The user can modify the IRCF bits to select a different frequency.

4.4.5 HF AND LF INTOSC CLOCK SWITCH TIMING

When switching between the LFINTOSC and the HFINTOSC, the new oscillator may already be shut down to save power. If this is the case, there is a 10 μ s delay after the IRCF bits are modified before the frequency selection takes place. The LTS/HTS bits will reflect the current active status of the LFINTOSC and the HFINTOSC oscillators. The timing of a frequency selection is as follows:

1. IRCF bits are modified.
2. If the new clock is shut down, a 10 μ s clock start-up delay is started.
3. Clock switch circuitry waits for a falling edge of the current clock.
4. CLKO is held low and the clock switch circuitry waits for a rising edge in the new clock.
5. CLKO is now connected with the new clock. HTS/LTS bits are updated as required.
6. Clock switch is complete.

If the internal oscillator speed selected is between 8 MHz and 125 kHz, there is no start-up delay before the new frequency is selected. This is because the old and the new frequencies are derived from the HFINTOSC via the postscaler and multiplexer.

4.5 Clock Switching

The system clock source can be switched between external and internal clock sources via software using the System Clock Select (SCS) bit.

4.5.1 SYSTEM CLOCK SELECT (SCS) BIT

The System Clock Select (SCS) bit (OSCCON<0>) selects the system clock source that is used for the CPU and peripherals.

- When SCS = 0, the system clock source is determined by configuration of the FOSC<2:0> bits in the Configuration Word register (CONFIG).
- When SCS = 1, the system clock source is chosen by the internal oscillator frequency selected by the IRCF bits. After a Reset, SCS is always cleared.

Note: Any automatic clock switch, which may occur from Two-Speed Start-up or Fail-Safe Clock Monitor, does not update the SCS bit. The user can monitor the OSTS (OSCCON<3>) to determine the current system clock source.

PIC16F917/916/914/913

4.5.2 OSCILLATOR START-UP TIME-OUT STATUS BIT

The Oscillator Start-up Time-out Status (OSTS) bit (OSCCON<3>) indicates whether the system clock is running from the external clock source, as defined by the FOSC bits, or from the internal clock source. In particular, OSTS indicates that the Oscillator Start-up Timer (OST) has timed out for LP, XT or HS modes.

4.6 Two-Speed Clock Start-up Mode

Two-Speed Start-up mode provides additional power savings by minimizing the latency between external oscillator start-up and code execution. In applications that make heavy use of the Sleep mode, Two-Speed Start-up will remove the external oscillator start-up time from the time spent awake and can reduce the overall power consumption of the device.

This mode allows the application to wake-up from Sleep, perform a few instructions using the INTOSC as the clock source and go back to Sleep without waiting for the primary oscillator to become stable.

Note: Executing a SLEEP instruction will abort the oscillator start-up time and will cause the OSTS bit (OSCCON<3>) to remain clear.

When the PIC16F917/916/914/913 is configured for LP, XT or HS modes, the Oscillator Start-up Timer (OST) is enabled (see **Section 4.3.1 “Oscillator Start-up Timer (OST)”**). The OST timer will suspend program execution until 1024 oscillations are counted. Two-Speed Start-up mode minimizes the delay in code execution by operating from the internal oscillator as the OST is counting. When the OST count reaches 1024 and the OSTS bit (OSCCON<3>) is set, program execution switches to the external oscillator.

4.6.1 TWO-SPEED START-UP MODE CONFIGURATION

Two-Speed Start-up mode is configured by the following settings:

- IESO = 1 (CONFIG<10>) Internal/External Switchover bit.
- SCS = 0.
- FOSC configured for LP, XT or HS mode.

Two-Speed Start-up mode is entered after:

- Power-on Reset (POR) and, if enabled, after PWRT has expired, or
- Wake-up from Sleep.

If the external clock oscillator is configured to be anything other than LP, XT or HS mode, then Two-Speed Start-up is disabled. This is because the external clock oscillator does not require any stabilization time after POR or an exit from Sleep.

4.6.2 TWO-SPEED START-UP SEQUENCE

1. Wake-up from Power-on Reset or Sleep.
2. Instructions begin execution by the internal oscillator at the frequency set in the IRCF bits (OSCCON<6:4>).
3. OST enabled to count 1024 clock cycles.
4. OST timed out, wait for falling edge of the internal oscillator.
5. OSTS is set.
6. System clock held low until the next falling edge of new clock (LP, XT or HS mode).
7. System clock is switched to external clock source.

4.6.3 CHECKING EXTERNAL/INTERNAL CLOCK STATUS

Checking the state of the OSTS bit (OSCCON<3>) will confirm if the PIC16F917/916/914/913 is running from the external clock source as defined by the FOSC bits in the Configuration Word (CONFIG) or the internal oscillator.

FIGURE 4-7: TWO-SPEED START-UP

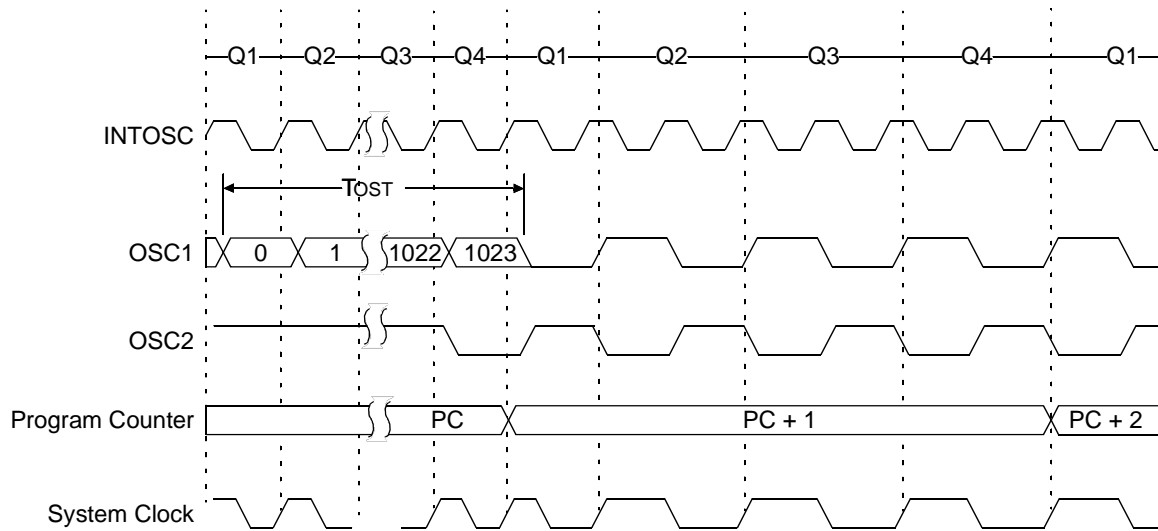

4.7 Fail-Safe Clock Monitor

The Fail-Safe Clock Monitor (FSCM) is designed to allow the device to continue to operate in the event of an oscillator failure. The FSCM can detect oscillator failure at any point after the device has exited a Reset or Sleep condition and the Oscillator Start-up Timer (OST) has expired.

FIGURE 4-8: FSCM BLOCK DIAGRAM

The frequency of the internal oscillator will depend upon the value contained in the IRCF bits (OSCCON<6:4>). Upon entering the Fail-Safe condition, the OSTS bit (OSCCON<3>) is automatically cleared to reflect that the internal oscillator is active and the WDT is cleared. The SCS bit (OSCCON<0>) is not updated. Enabling FSCM does not affect the LTS bit.

The FSCM sample clock is generated by dividing the INTOSC clock by 64. This will allow enough time between FSCM sample clocks for a system clock edge to occur. Figure 4-8 shows the FSCM block diagram.

On the rising edge of the sample clock, a monitoring latch (CM = 0) will be cleared. On a falling edge of the primary system clock, the monitoring latch will be set (CM = 1). In the event that a falling edge of the sample clock occurs, and the monitoring latch is not set, a clock failure has been detected. The assigned internal oscillator is enabled when FSCM is enabled as reflected by the IRCF.

The FSCM function is enabled by setting the FCMEN bit in the Configuration Word (CONFIG). It is applicable to all external clock options (LP, XT, HS, EC or RC modes).

In the event of an external clock failure, the FSCM will set the OSFIF bit (PIR2<7>) and generate an oscillator fail interrupt if the OSFIE bit (PIE2<7>) is set. The device will then switch the system clock to the internal oscillator. The system clock will continue to come from the internal oscillator unless the external clock recovers and the Fail-Safe condition is exited.

PIC16F917/916/914/913

4.7.1 FAIL-SAFE CONDITION CLEARING

The Fail-Safe condition is cleared after a Reset, the execution of a `SLEEP` instruction, or a modification of the `SCS` bit. While in Fail-Safe condition, the PIC16F91X uses the internal oscillator as the system without exiting the Fail-Safe condition.

The Fail-Safe condition must be cleared before the `OSFIF` flag can be cleared.

FIGURE 4-9: FSCM TIMING DIAGRAM

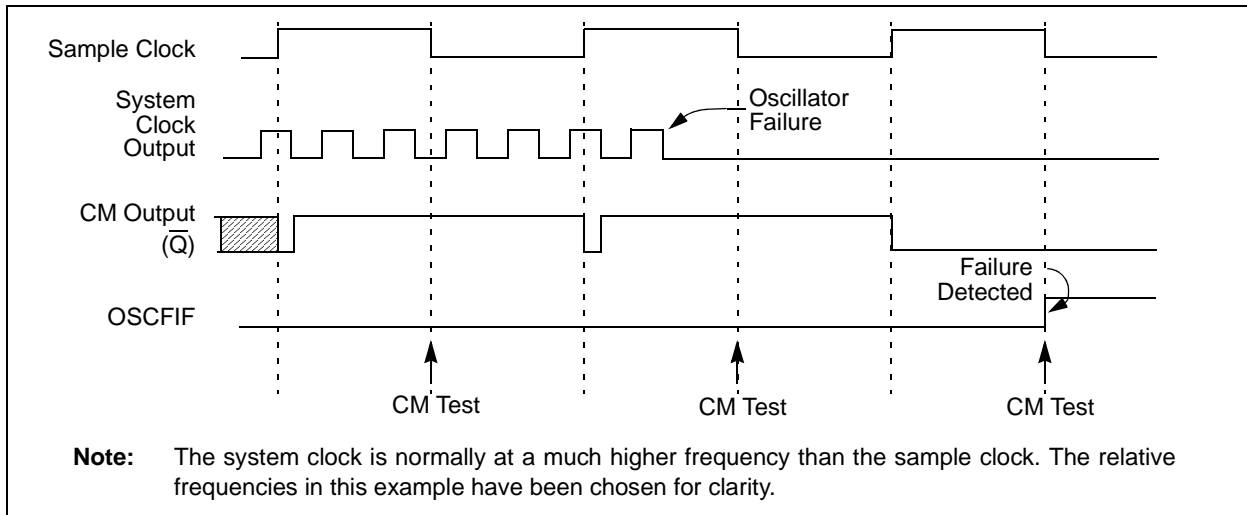

4.7.2 RESET OR WAKE-UP FROM SLEEP

The FSCM is designed to detect oscillator failure at any point after the device has exited a Reset or Sleep condition and the Oscillator Start-up Timer (OST) has expired. If the external clock is EC or RC mode, monitoring will begin immediately following these events.

For LP, XT or HS mode the external oscillator may require a start-up time considerably longer than the FSCM sample clock time, a false clock failure may be detected (see Figure 4-9). To prevent this, the internal oscillator is automatically configured as the system clock and functions until the external clock is stable (the OST has timed out). This is identical to Two-Speed Start-up mode. Once the external oscillator is stable, the `LFINTOSC` returns to its role as the FSCM source.

Note: Due to the wide range of oscillator start-up times, the Fail-Safe circuit is not active during oscillator start-up (i.e., after exiting Reset or Sleep). After an appropriate amount of time, the user should check the `OSTS` bit (`OSCCON<3>`) to verify the oscillator start-up and system clock switchover has successfully completed.

TABLE 4-2: SUMMARY OF REGISTERS ASSOCIATED WITH CLOCK SOURCES

Addr	Name	Bit 7	Bit 6	Bit 5	Bit 4	Bit 3	Bit 2	Bit 1	Bit 0	Value on: POR, BOR	Value on all other Resets
8Fh	OSCCON	—	IRCF2	IRCF1	IRCF0	OSTS ⁽²⁾	HTS	LTS	SCS	-110 q000	-110 x000
90h	OSCTUNE	—	—	—	TUN4	TUN3	TUN2	TUN1	TUN0	---0 0000	---u uuuu
2007h ⁽¹⁾	CONFIG	$\overline{\text{CPD}}$	$\overline{\text{CP}}$	MCLRE	$\overline{\text{PWRTE}}$	WDTE	FOSC2	FOSC1	FOSC0	—	—

Legend: x = unknown, u = unchanged, - = unimplemented locations read as '0'. Shaded cells are not used by oscillators.

Note 1: See Register 16-1 for operation of all Configuration Word bits.

Note 2: See Register 4-1 for details.

5.0 TIMER0 MODULE

The Timer0 module timer/counter has the following features:

- 8-bit timer/counter
- Readable and writable
- 8-bit software programmable prescaler
- Internal or external clock select
- Interrupt on overflow from FFh to 00h
- Edge select for external clock

Figure 5-1 is a block diagram of the Timer0 module and the prescaler shared with the WDT.

Note: Additional information on the Timer0 module is available in the “PICmicro® Mid-Range MCU Family Reference Manual” (DS33023).

5.1 Timer0 Operation

Timer mode is selected by clearing the T0CS bit (OPTION_REG<5>). In Timer mode, the Timer0 module will increment every instruction cycle (without prescaler). If TMR0 is written, the increment is inhibited for the following two instruction cycles. The user can work around this by writing an adjusted value to the TMR0 register.

Counter mode is selected by setting the T0CS bit (OPTION_REG<5>). In this mode, the Timer0 module will increment either on every rising or falling edge of pin RA4/C1OUT/T0CKI/SEG4. The incrementing edge is determined by the source edge (T0SE) control bit (OPTION_REG<4>). Clearing the T0SE bit selects the rising edge.

Note: Counter mode has specific external clock requirements. Additional information on these requirements is available in the “PICmicro® Mid-Range MCU Family Reference Manual” (DS33023).

5.2 Timer0 Interrupt

A Timer0 interrupt is generated when the TMR0 register timer/counter overflows from FFh to 00h. This overflow sets the T0IF bit (INTCON<2>). The interrupt can be masked by clearing the T0IE bit (INTCON<5>). The T0IF bit must be cleared in software by the Timer0 module Interrupt Service Routine before re-enabling this interrupt. The Timer0 interrupt cannot wake the processor from Sleep, since the timer is shut off during Sleep.

FIGURE 5-1: BLOCK DIAGRAM OF THE TIMER0/WDT PRESCALER

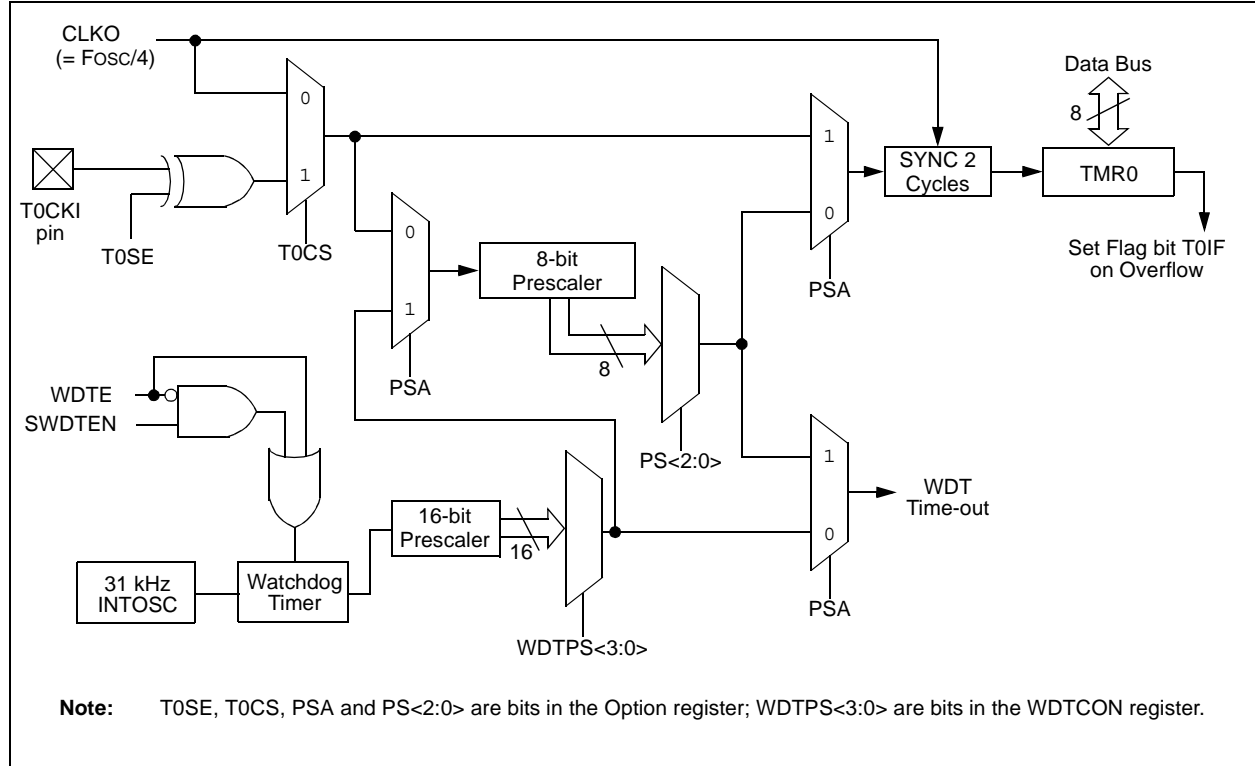

PIC16F917/916/914/913

5.3 Using Timer0 with an External Clock

When no prescaler is used, the external clock input is the same as the prescaler output. The synchronization of T0CKI, with the internal phase clocks, is accomplished by sampling the prescaler output on the Q2 and Q4 cycles of the internal phase clocks. Therefore, it is necessary for T0CKI to be high for at least 2 T_{OSC} (and a small RC delay of 20 ns) and low for at least 2 T_{OSC} (and a small RC delay of 20 ns). Refer to the electrical specification of the desired device.

REGISTER 5-1: OPTION_REG – OPTION REGISTER (ADDRESS: 81h OR 181h)

R/W-1	R/W-1	R/W-1	R/W-1	R/W-1	R/W-1	R/W-1	R/W-1
RBP \bar{U}	INTEDG	T0CS	T0SE	PSA	PS2	PS1	PS0
bit 7						bit 0	

- bit 7 **RBP \bar{U}** : PORTB Pull-up Enable bit
1 = PORTB pull-ups are disabled
0 = PORTB pull-ups are enabled by individual port latch values in WPUA register
- bit 6 **INTEDG**: Interrupt Edge Select bit
1 = Interrupt on rising edge of RB0/INT/SEG0 pin
0 = Interrupt on falling edge of RB0/INT/SEG0 pin
- bit 5 **T0CS**: TMR0 Clock Source Select bit
1 = Transition on RA4/C1OUT/T0CKI/SEG4 pin
0 = Internal instruction cycle clock (CLKO)
- bit 4 **T0SE**: TMR0 Source Edge Select bit
1 = Increment on high-to-low transition on RA4/C1OUT/T0CKI/SEG4 pin
0 = Increment on low-to-high transition on RA4/C1OUT/T0CKI/SEG4 pin
- bit 3 **PSA**: Prescaler Assignment bit
1 = Prescaler is assigned to the WDT
0 = Prescaler is assigned to the Timer0 module
- bit 2-0 **PS<2:0>**: Prescaler Rate Select bits

Bit Value	TMR0 Rate	WDT Rate ⁽¹⁾
000	1 : 2	1 : 1
001	1 : 4	1 : 2
010	1 : 8	1 : 4
011	1 : 16	1 : 8
100	1 : 32	1 : 16
101	1 : 64	1 : 32
110	1 : 128	1 : 64
111	1 : 256	1 : 128

Note 1: A dedicated 16-bit WDT postscaler is available for the PIC16F917/916/914/913. See Section 16.6 “Watchdog Timer (WDT)” for more information.

Legend:			
R = Readable bit	W = Writable bit	U = Unimplemented bit, read as ‘0’	
- n = Value at POR	‘1’ = Bit is set	‘0’ = Bit is cleared	x = Bit is unknown

5.4 Prescaler

An 8-bit counter is available as a prescaler for the Timer0 module, or as a postscaler for the Watchdog Timer. For simplicity, this counter will be referred to as “prescaler” throughout this data sheet. The prescaler assignment is controlled in software by the control bit PSA (OPTION_REG<3>). Clearing the PSA bit will assign the prescaler to Timer0. Prescale values are selectable via the PS<2:0> bits (OPTION_REG<2:0>).

The prescaler is not readable or writable. When assigned to the Timer0 module, all instructions writing to the TMR0 register (e.g., CLRF 1, MOVWF 1, BSF 1, x...etc.) will clear the prescaler. When assigned to WDT, a CLRWDT instruction will clear the prescaler along with the Watchdog Timer.

5.4.1 SWITCHING PRESCALER ASSIGNMENT

The prescaler assignment is fully under software control (i.e., it can be changed “on-the-fly” during program execution). To avoid an unintended device Reset, the following instruction sequence (Example 5-1 and Example 5-2) must be executed when changing the prescaler assignment from Timer0 to WDT.

EXAMPLE 5-1: CHANGING PRESCALER (TIMER0 → WDT)

```
BCF    STATUS,RP0    ;Bank 0
CLRWDT                ;Clear WDT
CLRF   TMR0          ;Clear TMR0 and
                    ; prescaler
BSF    STATUS,RP0    ;Bank 1

MOVLW  b'00101111'   ;Required if desired
MOVWF  OPTION_REG    ; PS2:PS0 is
CLRWDT                ; 000 or 001
                    ;
MOVLW  b'00101xxx'   ;Set postscaler to
MOVWF  OPTION_REG    ; desired WDT rate
BCF    STATUS,RP0    ;Bank 0
```

To change prescaler from the WDT to the TMR0 module, use the sequence shown in Example 5-2. This precaution must be taken even if the WDT is disabled.

EXAMPLE 5-2: CHANGING PRESCALER (WDT → TIMER0)

```
CLRWDT                ;Clear WDT and
                    ; prescaler
BSF    STATUS,RP0    ;Bank 1

MOVLW  b'xxx0xxx'    ;Select TMR0,
                    ; prescale, and
                    ; clock source
MOVWF  OPTION_REG    ;
BCF    STATUS,RP0    ;Bank 0
```

TABLE 5-1: REGISTERS ASSOCIATED WITH TIMER0

Address	Name	Bit 7	Bit 6	Bit 5	Bit 4	Bit 3	Bit 2	Bit 1	Bit 0	Value on POR, BOR	Value on all other Resets
01h	TMR0	Timer0 Module Register								xxxx xxxx	uuuu uuuu
0Bh/10Bh	INTCON	GIE	PEIE	TOIE	INTE	RBIE	TOIF	INTF	RBIF	0000 000x	0000 000x
81h	OPTION_REG	RBPU	INTEDG	T0CS	T0SE	PSA	PS2	PS1	PS0	1111 1111	1111 1111
85h	TRISA	TRISA7	TRISA6	TRISA5	TRISA4	TRISA3	TRISA2	TRISA1	TRISA0	1111 1111	1111 1111

Legend: - = Unimplemented locations, read as '0', u = unchanged, x = unknown. Shaded cells are not used by the Timer0 module.

PIC16F917/916/914/913

NOTES:

6.0 TIMER1 MODULE WITH GATE CONTROL

The PIC16F917/916/914/913 has a 16-bit timer. Figure 6-1 shows the basic block diagram of the Timer1 module. Timer1 has the following features:

- 16-bit timer/counter (TMR1H:TMR1L)
- Readable and writable
- Internal or external clock selection
- Synchronous or asynchronous operation
- Interrupt-on-overflow from FFFFh to 0000h
- Wake-up upon overflow (Asynchronous mode)
- Optional external enable input:
 - Selectable gate source: $\overline{T1G}$ or C2 output (T1GSS)
 - Selectable gate polarity (T1GINV)
- Optional LP oscillator

The Timer1 Control register (T1CON), shown in Register 6-1, is used to enable/disable Timer1 and select the various features of the Timer1 module.

Note: Additional information on timer modules is available in the "PICmicro® Mid-Range MCU Family Reference Manual" (DS33023).

FIGURE 6-1: TIMER1 ON THE PIC16F917/916/914/913 BLOCK DIAGRAM

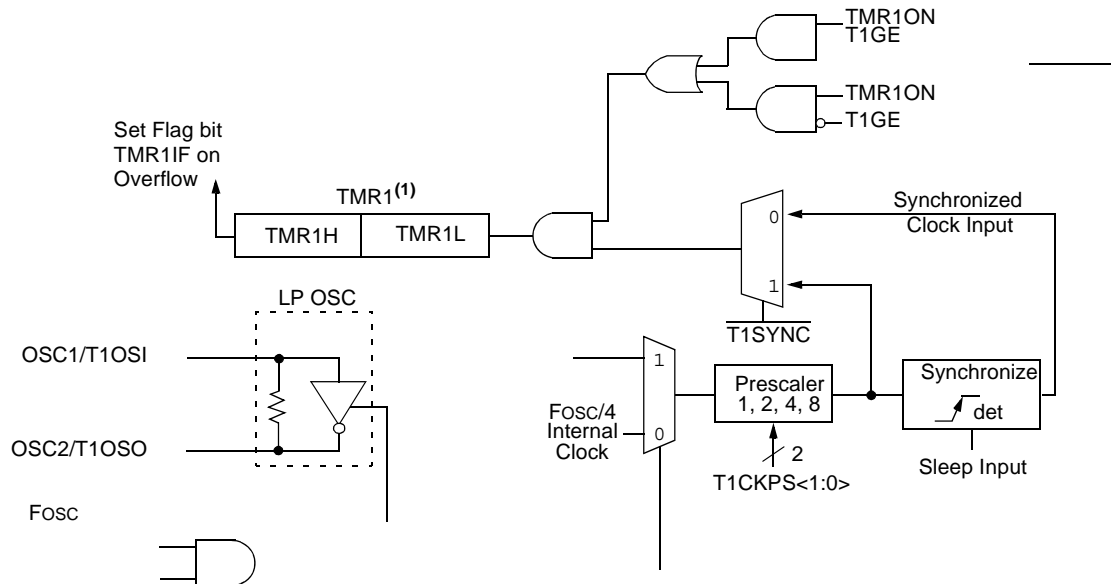

PIC16F917/916/914/913

6.1 Timer1 Modes of Operation

Timer1 can operate in one of three modes:

- 16-bit timer with prescaler
- 16-bit synchronous counter
- 16-bit asynchronous counter

In Timer mode, Timer1 is incremented on every instruction cycle. In Counter mode, Timer1 is incremented on the rising edge of the external clock input T1CKI. In addition, the Counter mode clock can be synchronized to the microcontroller system clock or run asynchronously.

In the Timer1 module, the module clock can be gated by the Timer1 gate, which can be selected as either the $\overline{T1G}$ pin or Comparator 2 output.

If an external clock oscillator is needed (and the microcontroller is using the INTOSC without CLKO), Timer1 can use the LP oscillator as a clock source.

Note: In Counter mode, a falling edge must be registered by the counter prior to the first incrementing rising edge.

6.2 Timer1 Interrupt

The Timer1 register pair (TMR1H:TMR1L) increments to FFFFh and rolls over to 0000h. When Timer1 rolls over, the Timer1 Interrupt Flag bit (PIR1<0>) is set. To enable the interrupt on rollover, you must set these bits:

- Timer1 Interrupt Enable bit (PIE1<0>)
- PEIE bit (INTCON<6>)
- GIE bit (INTCON<7>)

The interrupt is cleared by clearing the TMR1IF bit in the Interrupt Service Routine.

Note: The TMR1H:TMR1L register pair and the TMR1IF bit should be cleared before enabling interrupts.

6.3 Timer1 Prescaler

Timer1 has four prescaler options allowing 1, 2, 4 or 8 divisions of the clock input. The T1CKPS bits (T1CON<5:4>) control the prescale counter. The prescale counter is not directly readable or writable; however, the prescaler counter is cleared upon a write to TMR1H or TMR1L.

6.4 Timer1 Gate

Timer1 gate source is software configurable to be the $\overline{T1G}$ pin or the output of Comparator 2. This allows the device to directly time external events using $\overline{T1G}$ or analog events using Comparator 2. See CMCON1 (Register 8-2) for selecting the Timer1 gate source. This feature can simplify the software for a Delta-Sigma A/D converter and many other applications. For more information on Delta-Sigma A/D converters, see the Microchip web site (www.microchip.com).

Note: T1GE bit (T1CON<6>) must be set to use either $\overline{T1G}$ or C2OUT as the Timer1 gate source. See Register 8-2 for more information on selecting the Timer1 gate source.

Timer1 gate can be inverted using the T1GINV bit (T1CON<7>), whether it originates from the $\overline{T1G}$ pin or Comparator 2 output. This configures Timer1 to measure either the active-high or active-low time between events.

FIGURE 6-2: TIMER1 INCREMENTING EDGE

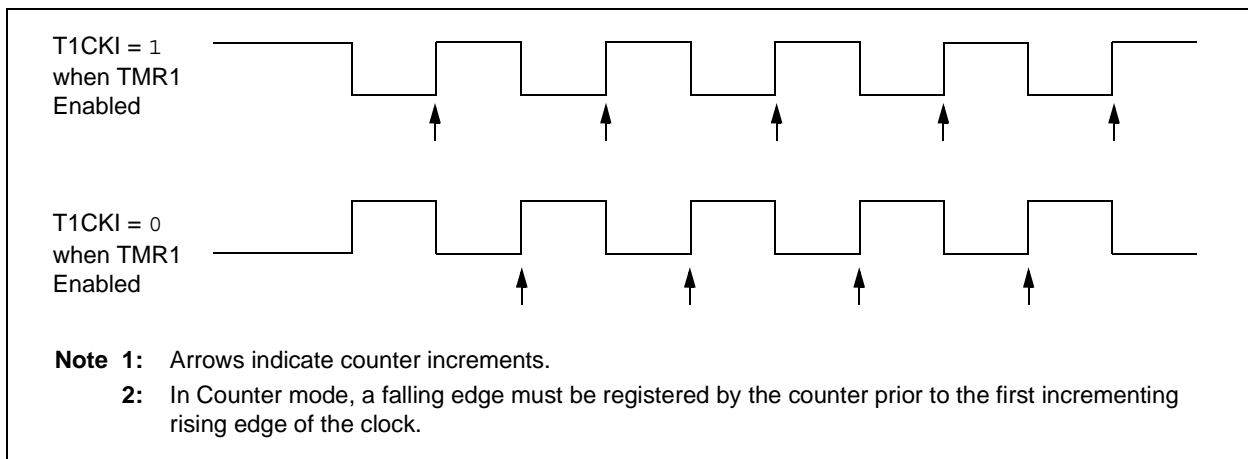

PIC16F917/916/914/913

REGISTER 6-1: T1CON – TIMER1 CONTROL REGISTER (ADDRESS: 10h)

R/W-0	R/W-0	R/W-0	R/W-0	R/W-0	R/W-0	R/W-0	R/W-0
T1GINV	T1GE	T1CKPS1	T1CKPS0	T1OSCN	$\overline{T1SYNC}$	TMR1CS	TMR1ON

bit 7

bit 0

- bit 7 **T1GINV:** Timer1 Gate Invert bit⁽¹⁾
 1 = Timer1 gate is inverted
 0 = Timer1 gate is not inverted
- bit 6 **T1GE:** Timer1 Gate Enable bit⁽²⁾
If TMR1ON = 0:
 This bit is ignored.
If TMR1ON = 1:
 1 = Timer1 gate is enabled
 0 = Timer1 gate is disabled
- bit 5-4 **T1CKPS<1:0>:** Timer1 Input Clock Prescale Select bits
 11 = 1:8 Prescale Value
 10 = 1:4 Prescale Value
 01 = 1:2 Prescale Value
 00 = 1:1 Prescale Value
- bit 3 **T1OSCN:** LP Oscillator Enable Control bit
If INTOSC without CLKO oscillator is active:
 1 = LP oscillator is enabled for Timer1 clock
 0 = LP oscillator is off
Else:
 This bit is ignored.
- bit 2 **T1SYNC:** Timer1 External Clock Input Synchronization Control bit
TMR1CS = 1:
 1 = Do not synchronize external clock input
 0 = Synchronize external clock input
TMR1CS = 0:
 This bit is ignored. Timer1 uses the internal clock.
- bit 1 **TMR1CS:** Timer1 Clock Source Select bit
 1 = External clock from RC5/T1CKI/CCP1/SEG10 pin or T1OSC (on the rising edge)
 0 = Internal clock (Fosc/4)
- bit 0 **TMR1ON:** Timer1 On bit
 1 = Enables Timer1
 0 = Stops Timer1

Note 1: T1GINV bit inverts the Timer1 gate logic, regardless of source.

2: T1GE bit must be set to use either $\overline{T1G}$ pin or C2OUT, as selected by the T1GSS bit (CMCON1<1>), as a Timer1 gate source.

Legend:

R = Readable bit	W = Writable bit	U = Unimplemented bit, read as '0'
- n = Value at POR	'1' = Bit is set	'0' = Bit is cleared x = Bit is unknown

6.5 Timer1 Operation in Asynchronous Counter Mode

If control bit $\overline{T1SYNC}$ (T1CON<2>) is set, the external clock input is not synchronized. The timer continues to increment asynchronous to the internal phase clocks. The timer will continue to run during Sleep and can generate an interrupt-on-overflow, which will wake-up the processor. However, special precautions in software are needed to read/write the timer (see Section 6.5.1 “Reading and Writing Timer1 in Asynchronous Counter Mode”).

Note: The ANSEL (91h) and CMCON0 (9Ch) registers must be initialized to configure an analog channel as a digital input. Pins configured as analog inputs will read ‘0’.

6.5.1 READING AND WRITING TIMER1 IN ASYNCHRONOUS COUNTER MODE

Reading TMR1H or TMR1L, while the timer is running from an external asynchronous clock, will ensure a valid read (taken care of in hardware). However, the user should keep in mind that reading the 16-bit timer in two 8-bit values itself, poses certain problems, since the timer may overflow between the reads.

For writes, it is recommended that the user simply stop the timer and write the desired values. A write contention may occur by writing to the timer registers, while the register is incrementing. This may produce an unpredictable value in the timer register.

Reading the 16-bit value requires some care. Examples in the “PICmicro® Mid-Range MCU Family Reference Manual” (DS33023) show how to read and write Timer1 when it is running in Asynchronous mode.

6.6 TIMER1 OSCILLATOR

To minimize the multiplexing of peripherals on the I/O ports, the dedicated TMR1 oscillator, which is normally used for TMR1 real-time clock applications, is eliminated. Instead, the TMR1 module can enable the LP oscillator.

If the microcontroller is programmed to run from INTOSC with no CLKO or LP oscillator:

1. Setting the T1OSCEN and TMR1CS bits to ‘1’ will enable the LP oscillator to clock TMR1 while the microcontroller is clocked from either the INTOSC or LP oscillator. Note that the T1OSC and LP oscillators share the same circuitry. Therefore, when LP oscillator is selected and T1OSC is enabled, both the microcontroller and the Timer1 module share the same clock source.
2. Sleep mode does not shut off the LP oscillator operation (i.e., if the INTOSC oscillator runs the microcontroller, and T1OSCEN = 1 (TMR1 is running from the LP oscillator), then the LP oscillator will continue to run during Sleep mode.

In all oscillator modes **except** for INTOSC with no CLKOUT and LP, the T1OSC enable option is unavailable and is ignored.

Note: When INTOSC without CLKO oscillator is selected and T1OSCEN = 1, the LP oscillator will run continuously independent of the TMR1ON bit.

6.7 Resetting Timer1 Using a CCP Trigger Output

If the CCP1 or CCP2 module is configured in Compare mode to generate a “special event trigger” (CCP1M<3:0> = 1011), this signal will reset Timer1.

Note: The special event triggers from the CCP1 and CCP2 modules will not set interrupt flag bit, TMR1IF (PIR1<0>).

Timer1 must be configured for either Timer or Synchronized Counter mode to take advantage of this feature. If Timer1 is running in Asynchronous Counter mode, this Reset operation may not work.

In the event that a write to Timer1 coincides with a special event trigger from CCP1 or CCP2, the write will take precedence.

In this mode of operation, the CCPRxH:CCPRxL register pair effectively becomes the period register for Timer1.

6.8 Resetting of Timer1 Register Pair (TMR1H, TMR1L)

TMR1H and TMR1L registers are not reset to 00h on a POR, or any other Reset, except by the CCP1 and CCP2 special event triggers.

T1CON register is reset to 00h on a Power-on Reset, or a Brown-out Reset, which shuts off the timer and leaves a 1:1 prescale. In all other Resets, the register is unaffected.

6.9 Timer1 Operation During Sleep

Timer1 can only operate during Sleep when setup in Asynchronous Counter mode. In this mode, an external crystal or clock source can be used to increment the counter. To set up the timer to wake the device:

- Timer1 must be on (T1CON<0>)
- TMR1IE bit (PIE1<0>) must be set
- PEIE bit (INTCON<6>) must be set

The device will wake-up on an overflow. If the GIE bit (INTCON<7>) is set, the device will wake-up and jump to the Interrupt Service Routine (0004h) on an overflow. If the GIE bit is clear, execution will continue with the next instruction.

TABLE 6-1: REGISTERS ASSOCIATED WITH TIMER1

Addr	Name	Bit 7	Bit 6	Bit 5	Bit 4	Bit 3	Bit 2	Bit 1	Bit 0	Value on POR, BOR	Value on all other Resets
0Bh/ 8Bh	INTCON	GIE	PEIE	T0IE	INTE	RBIE	T0IF	INTF	RBIF	0000 000x	0000 000x
0Ch	PIR1	EEIF	ADIF	RCIF	TXIF	SSPIF	CCP1IF	TMR2IF	TMR1IF	0000 0000	0000 0000
0Eh	TMR1L	Holding Register for the Least Significant Byte of the 16-bit TMR1 Register								xxxx xxxx	uuuu uuuu
0Fh	TMR1H	Holding Register for the Most Significant Byte of the 16-bit TMR1 Register								xxxx xxxx	uuuu uuuu
10h	T1CON	T1GINV	T1GE	T1CKPS1	T1CKPS0	T1OSCEN	T1SYNC	TMR1CS	TMR1ON	0000 0000	uuuu uuuu
1Ah	CMCON1	—	—	—	—	—	—	T1GSS	C2SYNC	---- --10	---- --10
8Ch	PIE1	EEIE	ADIE	RCIE	TXIE	SSPIE	CCP1IE	TMR2IE	TMR1IE	0000 0000	0000 0000

Legend: x = unknown, u = unchanged, - = unimplemented, read as '0'. Shaded cells are not used by the Timer1 module.

PIC16F917/916/914/913

7.0 TIMER2 MODULE

The Timer2 module timer has the following features:

- 8-bit timer (TMR2 register)
- 8-bit period register (PR2)
- Readable and writable (both registers)
- Software programmable prescaler (1:1, 1:4, 1:16)
- Software programmable postscaler (1:1 to 1:16)
- Interrupt on TMR2 match with PR2

Timer2 has a control register shown in Register 7-1. TMR2 can be shut-off by clearing control bit TMR2ON (T2CON<2>) to minimize power consumption. Figure 7-1 is a simplified block diagram of the Timer2 module. The prescaler and postscaler selection of Timer2 are controlled by this register.

7.1 Timer2 Operation

Timer2 can be used as the PWM time base for the PWM mode of the CCP module. The TMR2 register is readable and writable, and is cleared on any device Reset. The input clock ($F_{OSC}/4$) has a prescale option of 1:1, 1:4 or 1:16, selected by control bits T2CKPSx (T2CON<1:0>). The match output of TMR2 goes through a 4-bit postscaler (which gives a 1:1 to 1:16 scaling inclusive) to generate a TMR2 interrupt (latched in flag bit TMR2IF, (PIR1<1>)).

The prescaler and postscaler counters are cleared when any of the following occurs:

- A write to the TMR2 register
- A write to the T2CON register
- Any device Reset (Power-on Reset, \overline{MCLR} Reset, Watchdog Timer Reset, or Brown-out Reset)

TMR2 is not cleared when T2CON is written.

REGISTER 7-1: T2CON – TIMER2 CONTROL REGISTER (ADDRESS: 12h)

U-0	R/W-0	R/W-0	R/W-0	R/W-0	R/W-0	R/W-0	R/W-0
—	TOUTPS3	TOUTPS2	TOUTPS1	TOUTPS0	TMR2ON	T2CKPS1	T2CKPS0
bit 7							bit 0

- bit 7 **Unimplemented:** Read as '0'
- bit 6-3 **TOUTPS<3:0>:** Timer2 Output Postscale Select bits
 0000 =1:1 Postscale
 0001 =1:2 Postscale
 •
 •
 •
 1111 =1:16 Postscale
- bit 2 **TMR2ON:** Timer2 On bit
 1 = Timer2 is on
 0 = Timer2 is off
- bit 1-0 **T2CKPS<1:0>:** Timer2 Clock Prescale Select bits
 00 =Prescaler is 1
 01 =Prescaler is 4
 1x =Prescaler is 16

Legend:

R = Readable bit	W = Writable bit	U = Unimplemented bit, read as '0'
- n = Value at POR	'1' = Bit is set	'0' = Bit is cleared x = Bit is unknown

7.2 Timer2 Interrupt

The Timer2 module has an 8-bit period register, PR2. Timer2 increments from 00h until it matches PR2 and then resets to 00h on the next increment cycle. PR2 is a readable and writable register. The PR2 register is initialized to FFh upon Reset.

7.3 Timer2 Output

The output of TMR2 (before the postscaler) is fed to the SSP module, which optionally uses it to generate the shift clock.

FIGURE 7-1: TIMER2 BLOCK DIAGRAM

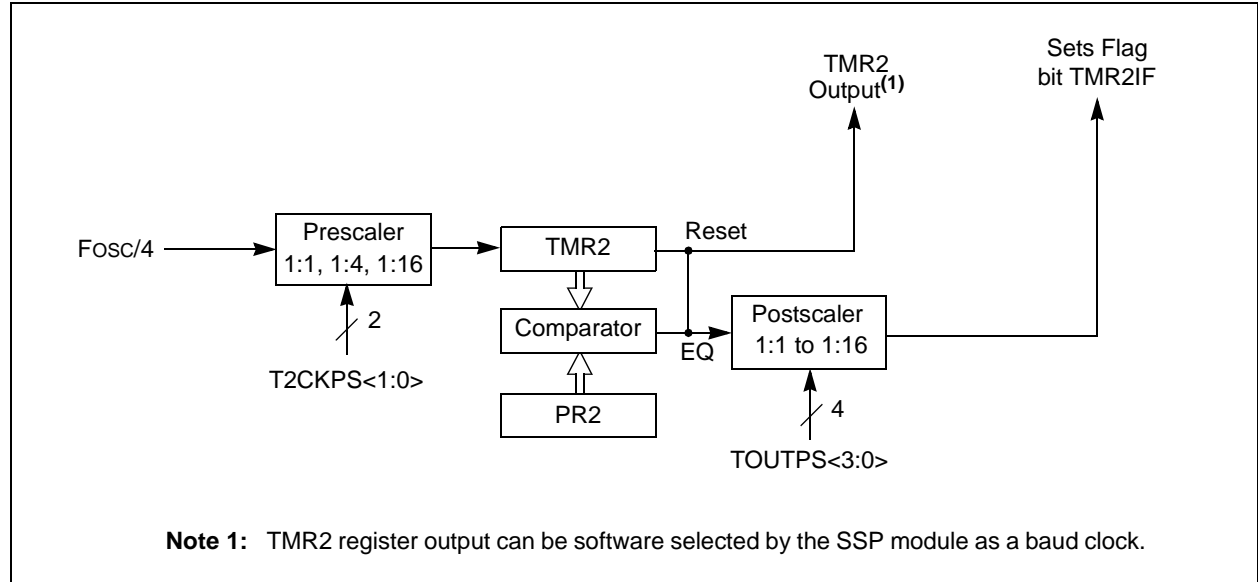

TABLE 7-1: REGISTERS ASSOCIATED WITH TIMER2

Addr	Name	Bit 7	Bit 6	Bit 5	Bit 4	Bit 3	Bit 2	Bit 1	Bit 0	Value on POR, BOR	Value on all other Resets
0Bh/8Bh	INTCON	GIE	PEIE	TOIE	INTE	RBIE	TOIF	INTF	RBIF	0000 000x	0000 000x
0Ch	PIR1	EEIF	ADIF	RCIF	TXIF	SSPIF	CCP1IF	TMR2IF	TMR1IF	0000 0000	0000 0000
11h	TMR2	Holding Register for the 8-bit TMR2 Register								0000 0000	0000 0000
12h	T2CON	—	TOUTPS3	TOUTPS2	TOUTPS1	TOUTPS0	TMR2ON	T2CKPS1	T2CKPS0	-000 0000	-000 0000
8Ch	PIE1	EEIE	ADIE	RCIE	TXIE	SSPIE	CCP1IE	TMR2IE	TMR1IE	0000 0000	0000 0000
92h	PR2	Timer2 Period Register								1111 1111	1111 1111

Legend: x = unknown, u = unchanged, - = unimplemented, read as '0'. Shaded cells are not used by the Timer2 module.

PIC16F917/916/914/913

NOTES:

8.0 COMPARATOR MODULE

The comparator module contains two analog comparators. The inputs to the comparators are multiplexed with I/O port pins RA<3:0>, while the outputs are multiplexed to pins RA<5:4>. An on-chip Comparator Voltage Reference (CVREF) can also be applied to the inputs of the comparators.

The CMCON0 register (Register 8-1) controls the comparator input and output multiplexers. A block diagram of the various comparator configurations is shown in Figure 8-3.

REGISTER 8-1: CMCON0 – COMPARATOR CONFIGURATION REGISTER (ADDRESS: 9Ch)

R-0	R-0	R/W-0	R/W-0	R/W-0	R/W-0	R/W-0	R/W-0	
C2OUT	C1OUT	C2INV	C1INV	CIS	CM2	CM1	CM0	
bit 7								bit 0

bit 7 **C2OUT:** Comparator 2 Output bit

When C2INV = 0:

1 = C2 VIN+ > C2 VIN-

0 = C2 VIN+ < C2 VIN-

When C2INV = 1:

0 = C2 VIN+ > C2 VIN-

1 = C2 VIN+ < C2 VIN-

bit 6 **C1OUT:** Comparator 1 Output bit

When C1INV = 0:

1 = C1 VIN+ > C1 VIN-

0 = C1 VIN+ < C1 VIN-

When C1INV = 1:

0 = C1 VIN+ > C1 VIN-

1 = C1 VIN+ < C1 VIN-

bit 5 **C2INV:** Comparator 2 Output Inversion bit

1 = C2 Output inverted

0 = C2 Output not inverted

bit 4 **C1INV:** Comparator 1 Output Inversion bit

1 = C1 Output inverted

0 = C1 Output not inverted

bit 3 **CIS:** Comparator Input Switch bit

When CM<2:0> = 010:

1 = C1 VIN- connects to RA3/AN3/C1+/VREF+/SEG15

C2 VIN- connects to RA2/AN2/C2+/VREF-/COM2

0 = C1 VIN- connects to RA0/AN0/C1-/SEG12

C2 VIN- connects to RA1/AN1/C2-/SEG7

When CM<2:0> = 001:

1 = C1 VIN- connects to RA3/AN3/C1+/VREF+/SEG15

0 = C1 VIN- connects to RA0/AN0/C1-/SEG12

When CM<2:0> = 101:

1 = C2 VIN+ connects to internal 0.6V reference

0 = C2 VIN+ connects to RA2/AN2/C2+/VREF-/COM2

bit 2-0 **CM<2:0>:** Comparator Mode bits⁽¹⁾

See Figure 8-3 for comparator modes and CM<2:0> bit settings.

Note 1: Setting a pin to an analog input automatically disables the digital input circuitry, weak pull-ups, and interrupt-on-change if available. The corresponding TRIS bit must be set to Input mode in order to allow external control of the voltage on the pin.

Legend:

R = Readable bit

W = Writable bit

U = Unimplemented bit, read as '0'

- n = Value at POR

'1' = Bit is set

'0' = Bit is cleared

x = Bit is unknown

PIC16F917/916/914/913

8.1 Comparator Operation

A single comparator is shown in Figure 8-1 along with the relationship between the analog input levels and the digital output. When the analog input at V_{IN+} is less than the analog input V_{IN-} , the output of the comparator is a digital low level. When the analog input at V_{IN+} is greater than the analog input V_{IN-} , the output of the comparator is a digital high level. The shaded areas of the output of the comparator in Figure 8-1 represent the uncertainty due to input offsets and response time.

Note: To use C_{IN+} and C_{IN-} pins as analog inputs, the appropriate bits must be programmed in the $CMCON0$ (9Ch) register.

The polarity of the comparator output can be inverted by setting the $CxINV$ bits ($CMCON0<5:4>$). Clearing $CxINV$ results in a non-inverted output. A complete table showing the output state versus input conditions and the polarity bit is shown in Table 8-1.

TABLE 8-1: OUTPUT STATE VS. INPUT CONDITIONS

Input Conditions	C_{INV}	$CxOUT$
$V_{IN-} > V_{IN+}$	0	0
$V_{IN-} < V_{IN+}$	0	1
$V_{IN-} > V_{IN+}$	1	1
$V_{IN-} < V_{IN+}$	1	0

FIGURE 8-1: SINGLE COMPARATOR

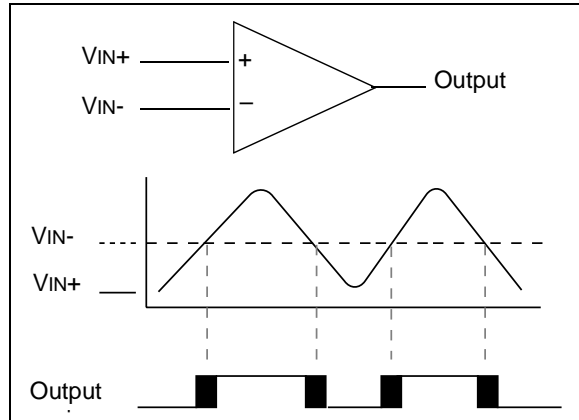

8.2 Analog Input Connection Considerations

A simplified circuit for an analog input is shown in Figure 8-2. Since the analog pins are connected to a digital output, they have reverse biased diodes to V_{DD} and V_{SS} . The analog input, therefore, must be between V_{SS} and V_{DD} . If the input voltage deviates from this range by more than 0.6V in either direction, one of the diodes is forward biased and a latch-up may occur. A maximum source impedance of 10 k Ω is recommended for the analog sources. Any external component connected to an analog input pin, such as a capacitor or a Zener diode, should have very little leakage.

FIGURE 8-2: ANALOG INPUT MODEL

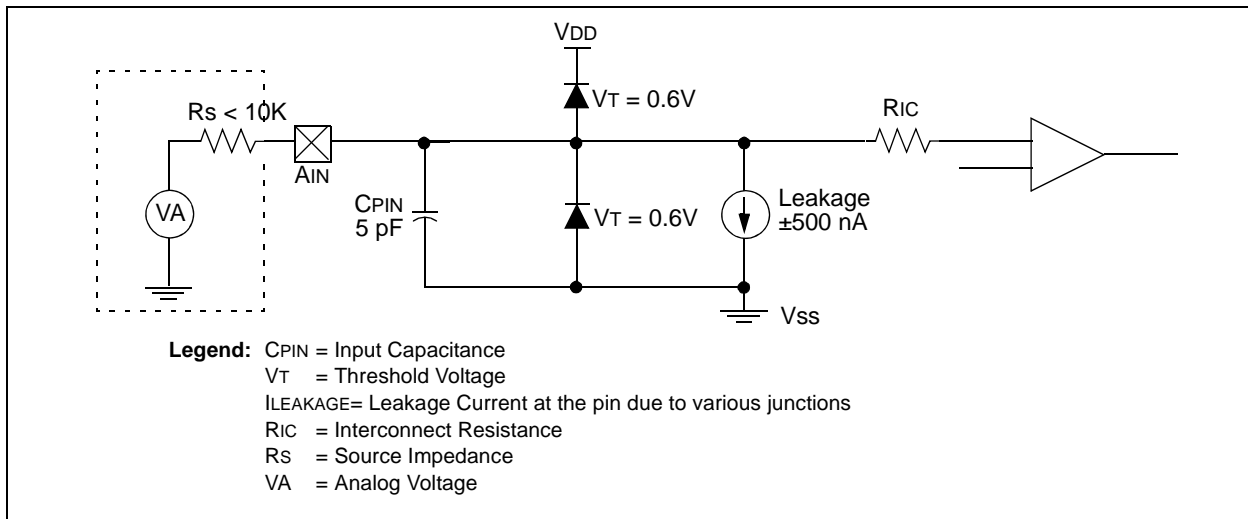

8.3 Comparator Configuration

There are eight modes of operation for the comparators. The CMCON0 register is used to select these modes. Figure 8-3 shows the eight possible modes.

If the Comparator mode is changed, the comparator output level may not be valid for the specified mode change delay shown in **Section 19.0 “Electrical Specifications”**.

Note: Comparator interrupts should be disabled during a Comparator mode change. Otherwise, a false interrupt may occur.

FIGURE 8-3: COMPARATOR I/O OPERATING MODES

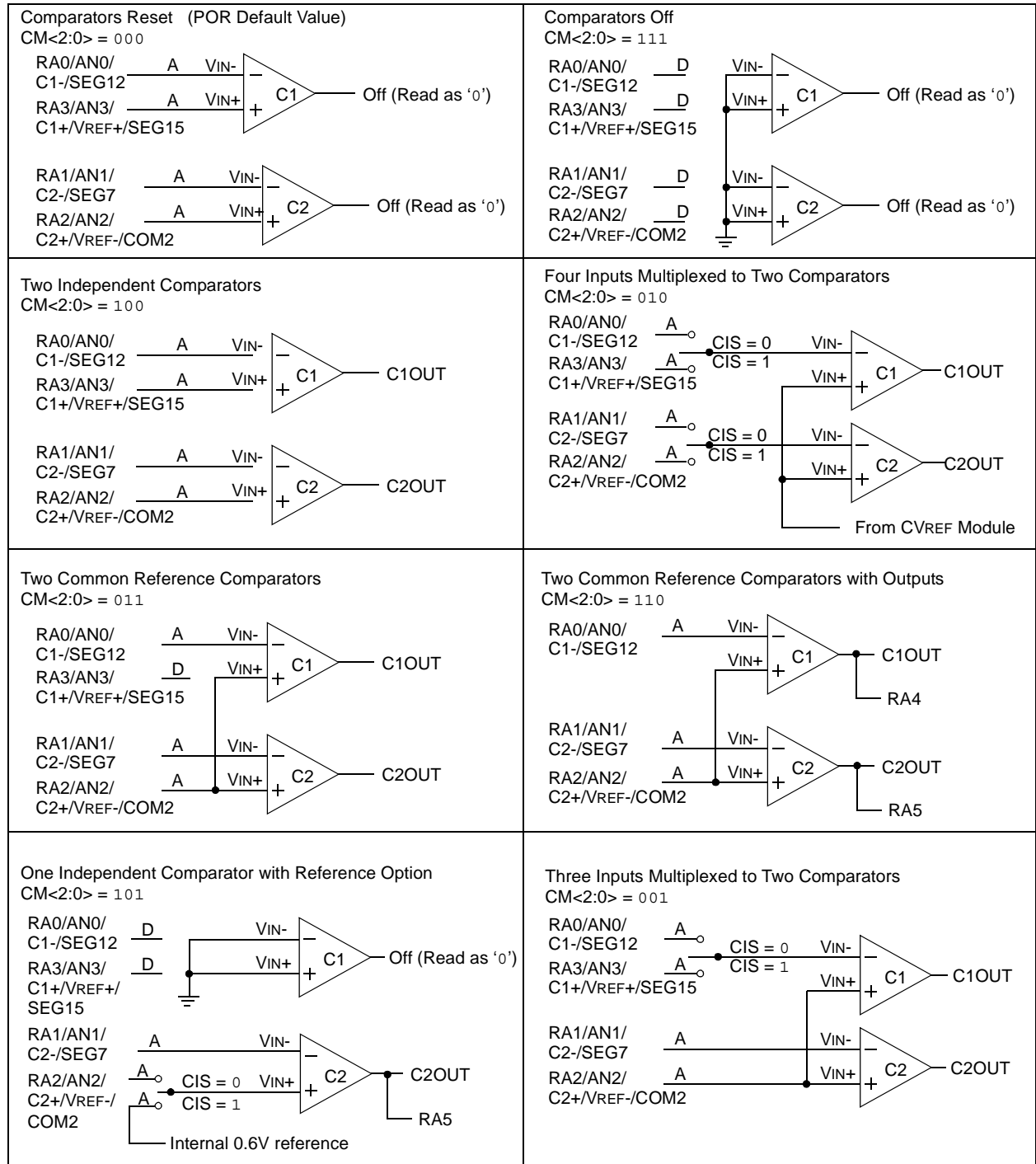

Legend:

A = Analog Input, port reads zeros always.

D = Digital Input.

CIS (CMCON0<3>) is the computer Input Switch.

PIC16F917/916/914/913

FIGURE 8-4: COMPARATOR C1 OUTPUT BLOCK DIAGRAM

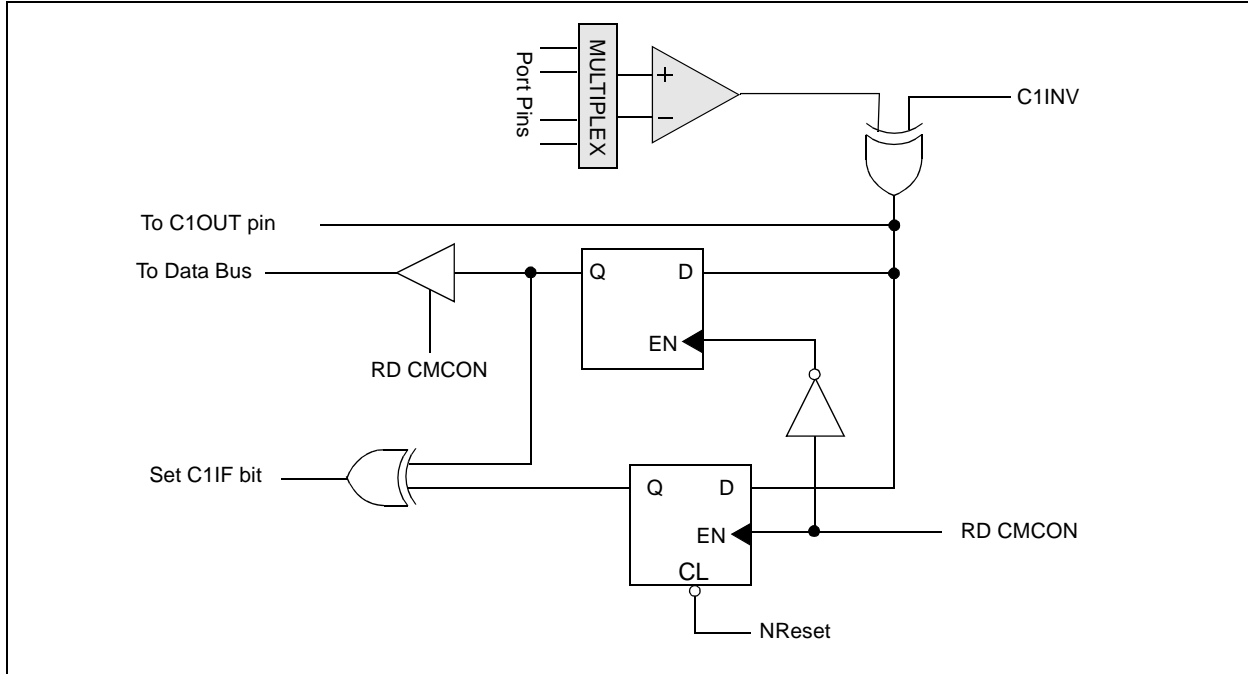
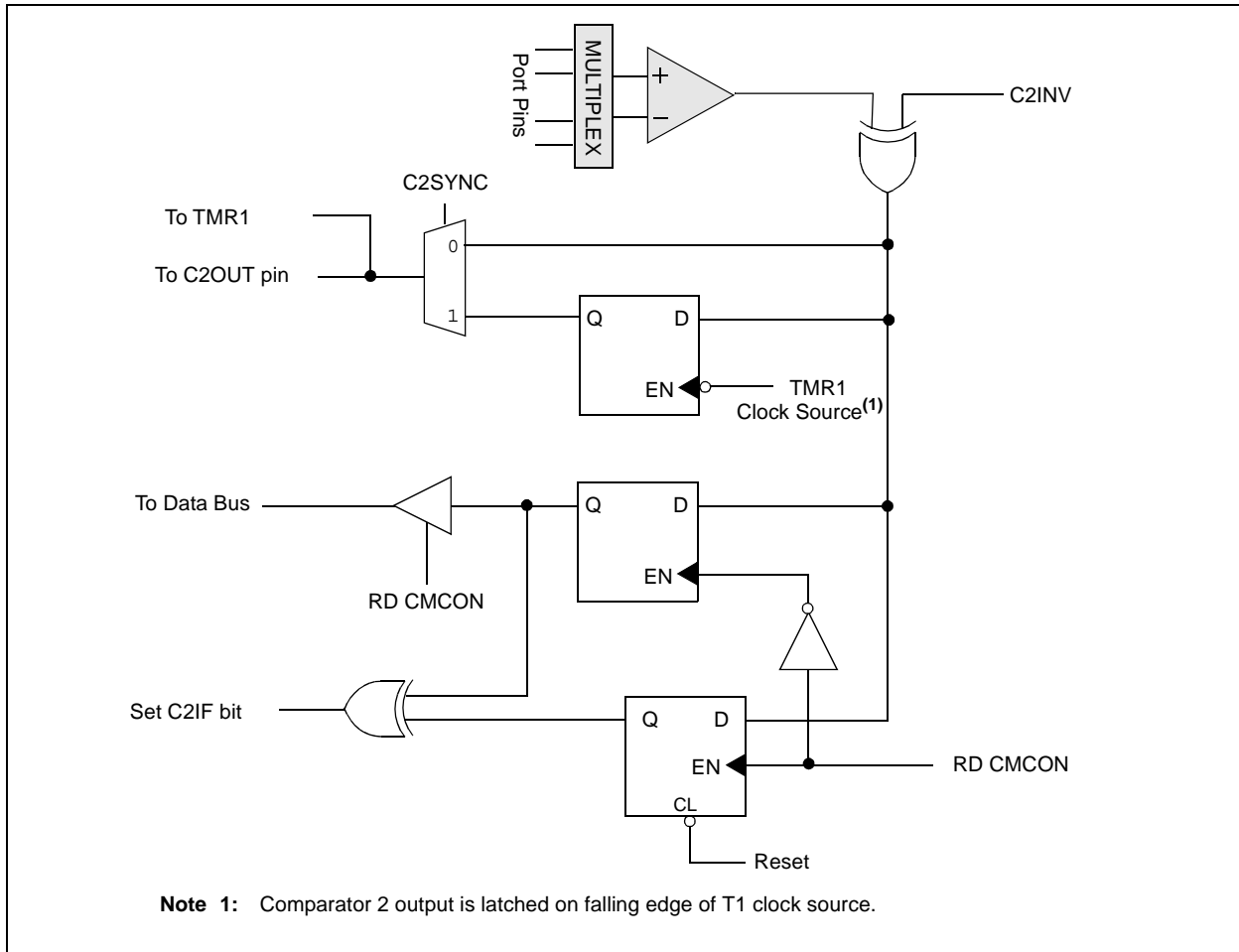

FIGURE 8-5: COMPARATOR C2 OUTPUT BLOCK DIAGRAM



Note 1: Comparator 2 output is latched on falling edge of T1 clock source.

REGISTER 8-2: CMCON1 – COMPARATOR CONFIGURATION REGISTER (ADDRESS: 97h)

U-0	U-0	U-0	U-0	U-0	U-0	R/W-1	R/W-0
—	—	—	—	—	—	T1GSS	C2SYNC
bit 7						bit 0	

bit 7-2: **Unimplemented:** Read as '0'

bit 1 **T1GSS:** Timer1 Gate Source Select bit

1 = Timer1 gate source is T1G pin (RC4 must be configured as digital input)

0 = Timer1 gate source is Comparator 2 Output

bit 0 **C2SYNC:** Comparator 2 Synchronize bit

1 = C2 output synchronized with falling edge of Timer1 clock

0 = C2 output not synchronized with Timer1 clock

Legend:

R = Readable bit

W = Writable bit

U = Unimplemented bit, read as '0'

- n = Value at POR

'1' = Bit is set

'0' = Bit is cleared

x = Bit is unknown

8.4 Comparator Outputs

The comparator outputs are read through the CMCON0 register. These bits are read-only. The comparator outputs may also be directly output to the RA4 and RA5 I/O pins. When enabled, multiplexers in the output path of the RA4 and RA5 pins will switch and the output of each pin will be the unsynchronized output of the comparator. The uncertainty of each of the comparators is related to the input offset voltage and the response time given in the specifications. Figure 8-4 and Figure 8-5 show the output block diagram for Comparator 1 and 2.

The TRIS bits will still function as an output enable/disable for the RA4 and RA5 pins while in this mode.

The polarity of the comparator outputs can be changed using the C1INV and C2INV bits (CMCON0<5:4>).

Timer1 gate source can be configured to use the T1G pin or Comparator 2 output as selected by the T1GSS bit (CMCON1<1>). This feature can be used to time the duration or interval of analog events. The output of Comparator 2 can also be synchronized with Timer1 by setting the C2SYNC bit (CMCON1<0>). When enabled, the output of Comparator 2 is latched on the falling edge of Timer1 clock source. If a prescaler is used with Timer1, Comparator 2 is latched after the prescaler. To prevent a race condition, the Comparator 2 output is latched on the falling edge of the Timer1 clock source and Timer1 increments on the rising edge of its clock source. See (Figure 8-5), Comparator 2 Block Diagram and (Figure 6-1), Timer1 Block Diagram for more information.

It is recommended to synchronize Comparator 2 with Timer1 by setting the C2SYNC bit when Comparator 2 is used as the Timer1 gate source. This ensures Timer1 does not miss an increment if Comparator 2 changes during an increment.

8.5 Comparator Interrupts

The comparator interrupt flags are set whenever there is a change in the output value of its respective comparator. Software will need to maintain information about the status of the output bits, as read from CMCON0<7:6>, to determine the actual change that has occurred. The CxIF bits, PIR2<6:5>, are the Comparator Interrupt flags. This bit must be reset in software by clearing it to '0'. Since it is also possible to write a '1' to this register, a simulated interrupt may be initiated.

The CxIE bits (PIE2<6:5>) and the PEIE bit (INTCON<6>) must be set to enable the interrupts. In addition, the GIE bit must also be set. If any of these bits are cleared, the interrupt is not enabled, though the CxIF bits will still be set if an interrupt condition occurs.

The user, in the Interrupt Service Routine, can clear the interrupt in the following manner:

- Any read or write of CMCON0. This will end the mismatch condition.
- Clear flag bit CxIF

A mismatch condition will continue to set flag bit CxIF. Reading CMCON0 will end the mismatch condition and allow flag bits CxIF to be cleared.

Note: If a change in the CMCON0 register (CxOUT) should occur when a read operation is being executed (start of the Q2 cycle), then the CxIF (PIR2<6:5>) interrupt flag may not get set.

PIC16F917/916/914/913

8.6 Comparator Reference

The comparator module also allows the selection of an internally generated voltage reference for one of the comparator inputs. The VRCON register, Register 8-3, controls the voltage reference module shown in Figure 8-6.

8.6.1 CONFIGURING THE VOLTAGE REFERENCE

The voltage reference can output 32 distinct voltage levels; 16 in a high range and 16 in a low range.

The following equation determines the output voltages:

EQUATION 8-1:

$$VRR = 1 \text{ (low range): } CVREF = (VR3:VR0/24) \times VDD$$

$$VRR = 0 \text{ (high range):}$$

$$CVREF = (VDD/4) + (VR3:VR0 \times VDD/32)$$

8.6.2 VOLTAGE REFERENCE ACCURACY/ERROR

The full range of V_{SS} to V_{DD} cannot be realized due to the construction of the module. The transistors on the top and bottom of the resistor ladder network (Figure 8-6) keep $CVREF$ from approaching V_{SS} or V_{DD} . The exception is when the module is disabled by clearing the VREN bit ($VRCON<7>$). When disabled, the reference voltage is V_{SS} when $VR<3:0> = 0000$. This allows the comparators to detect a zero-crossing and not consume $CVREF$ module current.

The voltage reference is V_{DD} derived and therefore, the $CVREF$ output changes with fluctuations in V_{DD} . The tested absolute accuracy of the comparator voltage reference can be found in **Section 19.0 “Electrical Specifications”**.

FIGURE 8-6: COMPARATOR VOLTAGE REFERENCE BLOCK DIAGRAM

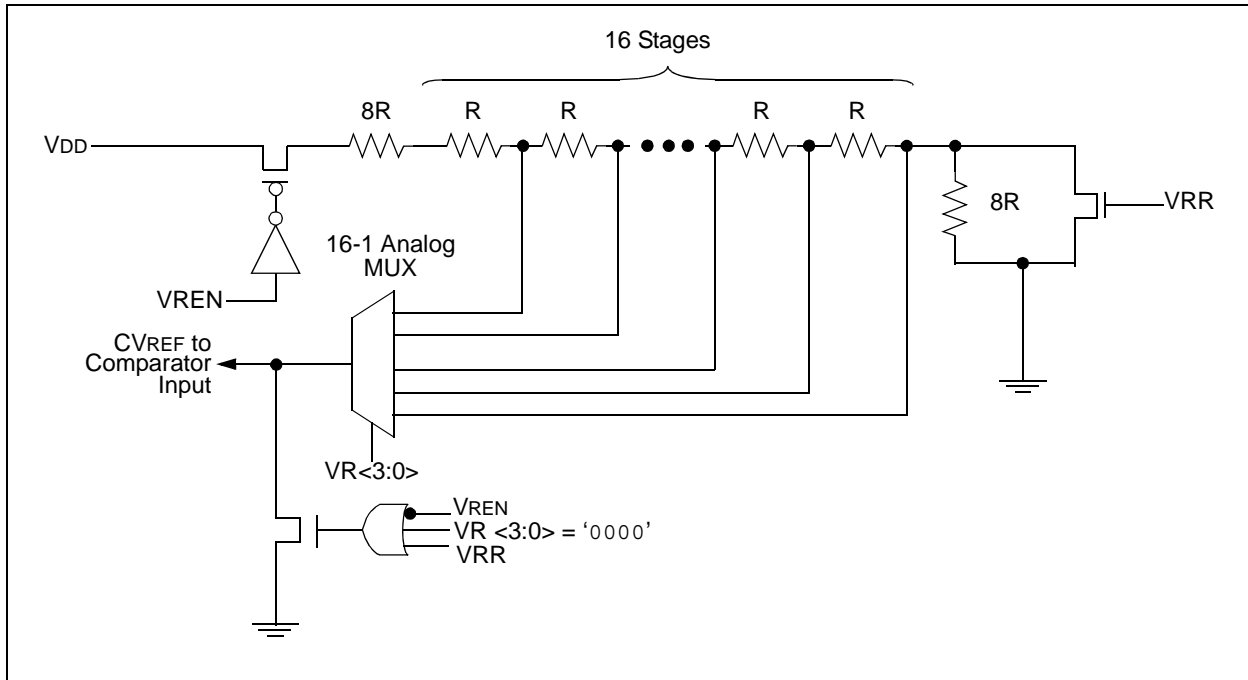

8.7 Comparator Response Time

Response time is the minimum time, after selecting a new reference voltage or input source, before the comparator output is ensured to have a valid level. If the internal reference is changed, the maximum delay of the internal voltage reference must be considered when using the comparator outputs. Otherwise, the maximum delay of the comparators should be used (Table 19-10).

8.8 Operation During Sleep

The comparators and voltage reference, if enabled before entering Sleep mode, remain active during Sleep. This results in higher Sleep currents than shown in the power-down specifications. The additional current consumed by the comparator and the voltage reference is shown separately in the specifications. To minimize power consumption while in Sleep mode, turn off the comparator, $CM\langle 2:0 \rangle = 111$, and voltage reference, $VRCON\langle 7 \rangle = 0$.

While the comparator is enabled during Sleep, an interrupt will wake-up the device. If the GIE bit ($INTCON\langle 7 \rangle$) is set, the device will jump to the interrupt vector (0004h), and if clear, continues execution with the next instruction. If the device wakes up from Sleep, the contents of the $CMCON0$, $CMCON1$ and $VRCON$ registers are not affected.

8.9 Effects of a Reset

A device Reset forces the $CMCON0$, $CMCON1$ and $VRCON$ registers to their Reset states. This forces the comparator module to be in the Comparator Reset mode, $CM\langle 2:0 \rangle = 000$ and the voltage reference to its OFF state. Thus, all potential inputs are analog inputs with the comparator and voltage reference disabled to consume the smallest current possible.

PIC16F917/916/914/913

REGISTER 8-3: VRCON – VOLTAGE REFERENCE CONTROL REGISTER (ADDRESS: 9Dh)

R/W-0	U-0	R/W-0	R/W-0	R/W-0	R/W-0	R/W-0	R/W-0
VREN	—	VRR	—	VR3	VR2	VR1	VR0
bit 7							bit 0

- bit 7 **VREN:** CVREF Enable bit
 1 = CVREF circuit powered on
 0 = CVREF circuit powered down, no IDD drain and CVREF = VSS.
- bit 6 **Unimplemented:** Read as '0'
- bit 5 **VRR:** CVREF Range Selection bit
 1 = Low range
 0 = High range
- bit 4 **Unimplemented:** Read as '0'
- bit 3-0 **VR<3:0>:** CVREF value selection $0 \leq VR<3:0> \leq 15$
 When VRR = 1: $CVREF = (VR<3:0>/24) * VDD$
 When VRR = 0: $CVREF = VDD/4 + (VR<3:0>/32) * VDD$

Legend:

R = Readable bit W = Writable bit U = Unimplemented bit, read as '0'
 - n = Value at POR '1' = Bit is set '0' = Bit is cleared x = Bit is unknown

TABLE 8-2: REGISTERS ASSOCIATED WITH COMPARATOR MODULE

Address	Name	Bit 7	Bit 6	Bit 5	Bit 4	Bit 3	Bit 2	Bit 1	Bit 0	Value on POR, BOR	Value on all other Resets
0Bh/8Bh	INTCON	GIE	PEIE	T0IE	INTE	RBIE	T0IF	INTF	RBIF	0000 000x	0000 000x
0Dh	PIR2	OSFIF	C2IF	C1IF	LCDIF	—	LVDIF	—	CCP2IF	0000 -0-0	0000 -0-0
9Ch	CMCON0	C2OUT	C1OUT	C2INV	C1INV	CIS	CM2	CM1	CM0	0000 0000	0000 0000
97h	CMCON1	—	—	—	—	—	—	T1GSS	C2SYNC	---- --10	---- --10
85h	TRISA	TRISA7	TRISA6	TRISA5	TRISA4	TRISA3	TRISA2	TRISA1	TRISA0	1111 1111	1111 1111
8Dh	PIE2	OSFIE	C2IE	C1IE	LCDIE	—	LVDIE	—	CCP2IE	0000 -0-0	0000 -0-0
9Dh	VRCON	VREN	—	VRR	—	VR3	VR2	VR1	VR0	0-0- 0000	0-0- 0000

Legend: x = unknown, u = unchanged, - = unimplemented, read as '0'. Shaded cells are not used by the comparator or Comparator Voltage Reference module.

9.0 LIQUID CRYSTAL DISPLAY (LCD) DRIVER MODULE

The Liquid Crystal Display (LCD) driver module generates the timing control to drive a static or multiplexed LCD panel. In the PIC16F914/917 devices (PIC16F914/917), the module drives the panels of up to four commons and up to 24 segments and in the PIC16F913/916 devices (PIC16F913/916), the module drives the panels of up to four commons and up to 16 segments. It also provides control of the LCD pixel data.

The LCD driver module supports:

- Direct driving of LCD panel
- Three LCD clock sources with selectable prescaler
- Up to four commons:
 - Static
 - 1/2 multiplex
 - 1/3 multiplex
 - 1/4 multiplex
- Up to 24 (in PIC16F914/917 devices)/16 (in PIC16F913/916 devices) segments
- Static, 1/2 or 1/3 LCD Bias

The module has 32 registers:

- LCD Control Register (LCDCON)
- LCD Phase Register (LCDPS)
- Three LCD Segment Enable Registers (LCDSE<2:0>)
- 24 LCD Data Registers (LCDDATA<11:0>)

The LCDCON register, shown in Register 9-1, controls the operation of the LCD driver module. The LCDPS register, shown in Register 9-2, configures the LCD clock source prescaler and the type of waveform; Type-A or Type-B. The LCDSE<2:0> registers configure the functions of the port pins:

- LCDSE0 SE<7:0>
- LCDSE1 SE<15:8>
- LCDSE2 SE<23:16>

As an example, LCDSEn is detailed in Register 9-3.

Note: The LCDSE2 register is not implemented in PIC16F913/916 devices.

Once the module is initialized for the LCD panel, the individual bits of the LCDDATA<11:0> registers are cleared/set to represent a clear/dark pixel, respectively:

- LCDDATA0 SEG7COM0:SEG0COM0
- LCDDATA1 SEG15COM0:SEG8COM0
- LCDDATA2 SEG23COM0:SEG16COM0
- LCDDATA3 SEG7COM1:SEG0COM1
- LCDDATA4 SEG15COM1:SEG8COM1
- LCDDATA5 SEG23COM1:SEG16COM1
- LCDDATA6 SEG7COM2:SEG0COM2
- LCDDATA7 SEG15COM2:SEG8COM2
- LCDDATA8 SEG23COM2:SEG16COM2
- LCDDATA9 SEG7COM3:SEG0COM3
- LCDDATA10 SEG15COM3:SEG8COM3
- LCDDATA11 SEG23COM3:SEG16COM3

As an example, LCDDATAx is detailed in Register 9-4.

Once the module is configured, the LCDEN (LCDCON<7>) bit is used to enable or disable the LCD module. The LCD panel can also operate during Sleep by clearing the SLPEN (LCDCON<6>) bit.

Note: Writing into the registers LCDDATA2, LCDDATA5, LCDDATA8 and LCDDATA11 in PIC16F913/916 devices will not affect the status of any pixel and these registers can be used as General Purpose Registers.

PIC16F917/916/914/913

FIGURE 9-1: LCD DRIVER MODULE BLOCK DIAGRAM

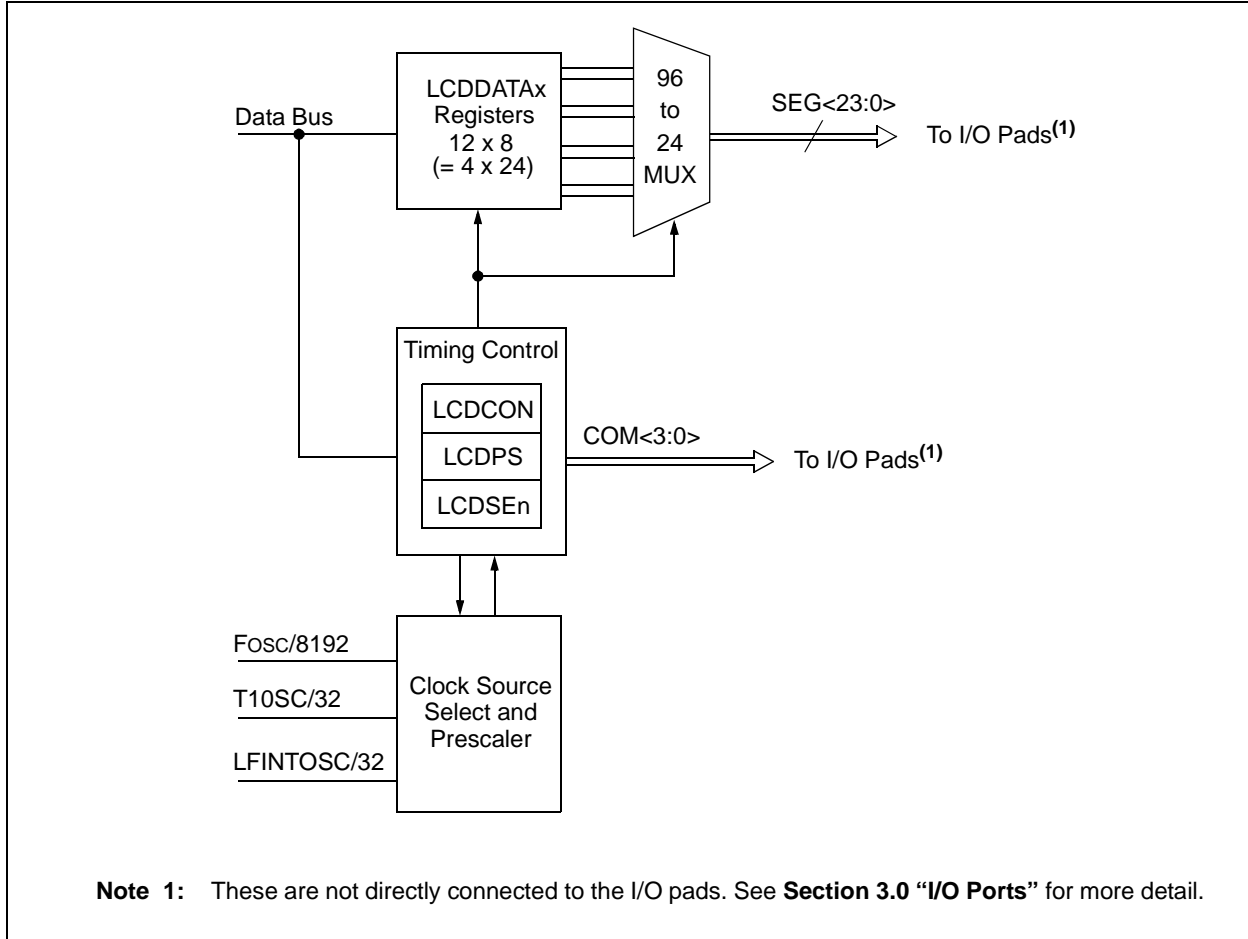

PIC16F917/916/914/913

REGISTER 9-1: LCDCON – LIQUID CRYSTAL DISPLAY CONTROL REGISTER (ADDRESS: 107h)

R/W-0	R/W-0	R/C-0	R/W-1	R/W-0	R/W-0	R/W-1	R/W-1
LCDEN	SLPEN	WERR	VLCDEN	CS1	CS0	LMUX1	LMUX0
bit 7						bit 0	

- bit 7 **LCDEN:** LCD Driver Enable bit
 1 = LCD driver module is enabled
 0 = LCD driver module is disabled
- bit 6 **SLPEN:** LCD Driver Enable in Sleep mode bit
 1 = LCD driver module is disabled in Sleep mode
 0 = LCD driver module is enabled in Sleep mode
- bit 5 **WERR:** LCD Write Failed Error bit
 1 = LCDDATAx register written while LCDPS<WA> = 0 (must be cleared in software)
 0 = No LCD write error
- bit 4 **VLCDEN:** LCD Bias Voltage Pins Enable bit
 1 = VLCD pins are enabled
 0 = VLCD pins are disabled
- bit 3-2 **CS<1:0>:** Clock Source Select bits
 00 = Fosc/8192
 01 = T1OSC (Timer1)/32
 1x = LFINTOSC (31 kHz)/32
- bit 1-0 **LMUX<1:0>:** Commons Select bits

LMUX<1:0>	Multiplex	Maximum Number of Pixels (PIC16F913/916)	Maximum Number of Pixels (PIC16F914/917)	Bias
00	Static (COM0)	16	24	Static
01	1/2 (COM<1:0>)	32	48	1/2 or 1/3
10	1/3 (COM<2:0>)	48	72	1/2 or 1/3
11	1/4 (COM<3:0>)	60 ⁽¹⁾	96	1/3

Note 1: On PIC16F913/916 devices, COM3 and SEG15 are shared on one pin, limiting the device from driving 64 pixels.

Legend:

R = Readable bit W = Writable bit U = Unimplemented bit, read as '0'
 C = Only clearable bit '1' = Bit is set '0' = Bit is cleared x = Bit is unknown
 - n = Value at POR

PIC16F917/916/914/913

REGISTER 9-2: LCDPS – LCD PRESCALER SELECT REGISTER (ADDRESS: 108h)

R/W-0	R/W-0	R-0	R-0	R/W-0	R/W-0	R/W-0	R/W-0
WFT	BIASMD	LCDA	WA	LP3	LP2	LP1	LP0
bit 7							bit 0

- bit 7 **WFT:** Waveform Type Select bit
 1 = Type-B waveform (phase changes on each frame boundary)
 0 = Type-A waveform (phase changes within each common type)
- bit 6 **BIASMD:** Bias Mode Select bit
When LMUX<1:0> = 00:
 0 = Static Bias mode (do not set this bit to '1')
When LMUX<1:0> = 01:
 1 = 1/2 Bias mode
 0 = 1/3 Bias mode
When LMUX<1:0> = 10:
 1 = 1/2 Bias mode
 0 = 1/3 Bias mode
When LMUX<1:0> = 11:
 0 = 1/3 Bias mode (do not set this bit to '1')
- bit 5 **LCDA:** LCD Active Status bit
 1 = LCD driver module is active
 0 = LCD driver module is inactive
- bit 4 **WA:** LCD Write Allow Status bit
 1 = Write into the LCDDATAx registers is allowed
 0 = Write into the LCDDATAx registers is not allowed
- bit 3-0 **LP<3:0>:** LCD Prescaler Select bits
 1111 = 1:16
 1110 = 1:15
 1101 = 1:14
 1100 = 1:13
 1011 = 1:12
 1010 = 1:11
 1001 = 1:10
 1000 = 1:9
 0111 = 1:8
 0110 = 1:7
 0101 = 1:6
 0100 = 1:5
 0011 = 1:4
 0010 = 1:3
 0001 = 1:2
 0000 = 1:1

Legend:			
R = Readable bit	W = Writable bit	U = Unimplemented bit, read as '0'	
- n = Value at POR	'1' = Bit is set	'0' = Bit is cleared	x = Bit is unknown

PIC16F917/916/914/913

REGISTER 9-3: LCDSEn – LCD SEGMENT REGISTERS (ADDRESS: 11Ch, 11Dh OR 11Eh)

R/W-0	R/W-0	R/W-0	R/W-0	R/W-0	R/W-0	R/W-0	R/W-0
SEn	SEn	SEn	SEn	SEn	SEn	SEn	SEn

bit 7 bit 0

bit 7-0 **SEn:** Segment Enable bits
1 = Segment function of the pin is enabled
0 = I/O function of the pin is enabled

Legend:

R = Readable bit W = Writable bit U = Unimplemented bit, read as '0'
- n = Value at POR '1' = Bit is set '0' = Bit is cleared x = Bit is unknown

REGISTER 9-4: LCDDATAx – LCD DATA REGISTERS (ADDRESS: 110h-119h, 11Ah, 11Bh)

R/W-0	R/W-0	R/W-0	R/W-0	R/W-0	R/W-0	R/W-0	R/W-0
SEGx-COMy	SEGx-COMy	SEGx-COMy	SEGx-COMy	SEGx-COMy	SEGx-COMy	SEGx-COMy	SEGx-COMy

bit 7 bit 0

bit 7-0 **SEGx-COMy:** Pixel On bits
1 = Pixel on (dark)
0 = Pixel off (clear)

Legend:

R = Readable bit W = Writable bit U = Unimplemented bit, read as '0'
- n = Value at POR '1' = Bit is set '0' = Bit is cleared x = Bit is unknown

PIC16F917/916/914/913

9.1 LCD Clock Source Selection

The LCD driver module has 3 possible clock sources:

- $F_{osc}/8192$
- $T1OSC/32$
- $LFINTOSC/32$

The first clock source is the system clock divided by 8192 ($F_{osc}/8192$). This divider ratio is chosen to provide about 1 kHz output when the system clock is 8 MHz. The divider is not programmable. Instead, the LCD prescaler bits, $LCDPS<3:0>$, are used to set the LCD frame clock rate.

The second clock source is the $T1OSC/32$. This also gives about 1 kHz when a 32.768 kHz crystal is used with the Timer1 oscillator. To use the Timer1 oscillator as a clock source, the $T1OSCEN$ ($T1CON<3>$) bit should be set.

The third clock source is the 31 kHz $LFINTOSC/32$, which provides approximately 1 kHz output.

The second and third clock sources may be used to continue running the LCD while the processor is in Sleep.

Using the bits, $CS<1:0>$ ($LCDCON<3:2>$), any of these clock sources can be selected.

9.1.1 LCD PRESCALER

A 16-bit counter is available as a prescaler for the LCD clock. The prescaler is not directly readable or writable; its value is set by the $LP<3:0>$ bits ($LCDPS<3:0>$), which determine the prescaler assignment and prescale ratio.

The prescale values from 1:1 through 1:16.

9.2 LCD Bias Types

The LCD driver module can be configured into three bias types:

- Static Bias (2 voltage levels: V_{SS} and V_{DD})
- 1/2 Bias (3 voltage levels: V_{SS} , $1/2 V_{DD}$ and V_{DD})
- 1/3 Bias (4 voltage levels: V_{SS} , $1/3 V_{DD}$, $2/3 V_{DD}$ and V_{DD})

This module uses an external resistor ladder to generate the LCD bias voltages.

The external resistor ladder should be connected to the Bias 1 pin, Bias 2 pin, Bias 3 pin and V_{SS} . The Bias 3 pin should also be connected to V_{DD} .

Figure 9-2 shows the proper way to connect the resistor ladder to the Bias pins.

Note: VLCD pins used to supply LCD bias voltage are enabled on power-up (POR) and must be disabled by the user by clearing $LCDCON<4>$, the $VLCDEN$ bit, (see Register 9-1).

FIGURE 9-2: LCD BIAS RESISTOR LADDER CONNECTION DIAGRAM

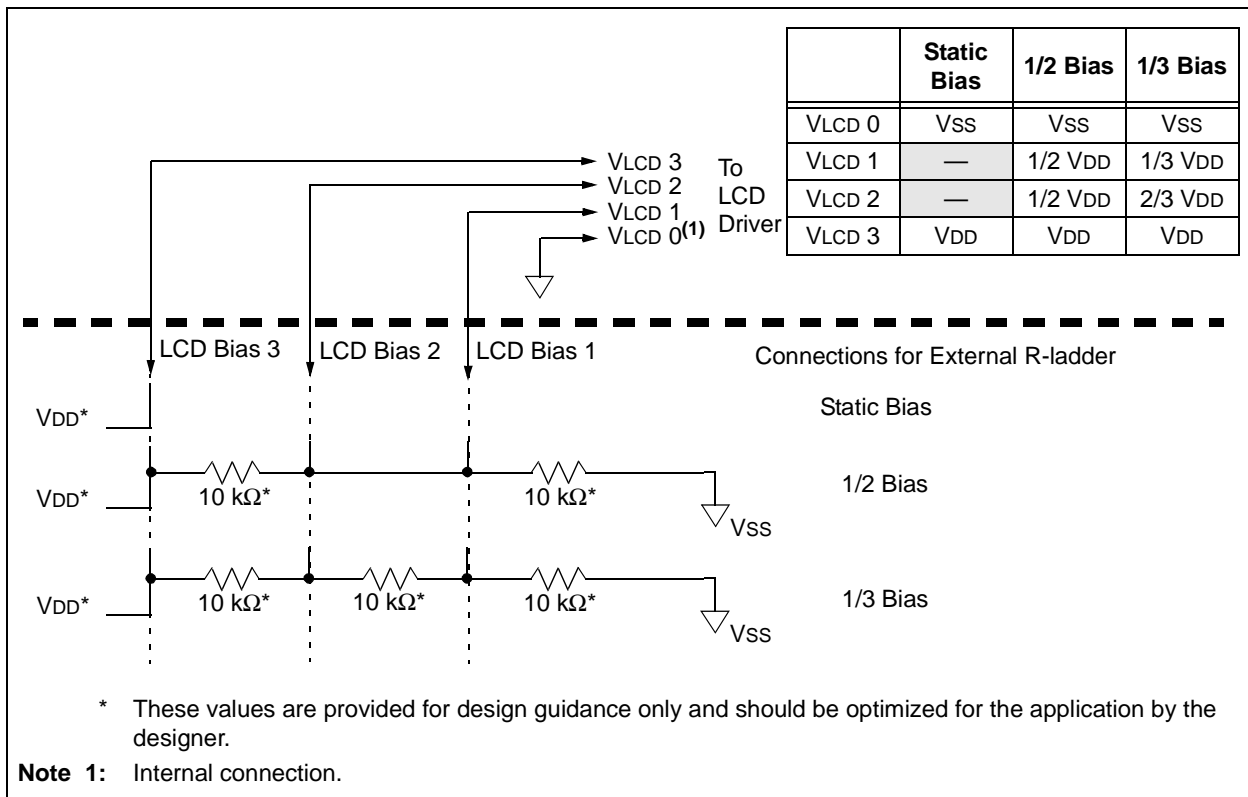

9.3 LCD Multiplex Types

The LCD driver module can be configured into four multiplex types:

- Static (only COM0 used)
- 1/2 multiplex (COM0 and COM1 are used)
- 1/3 multiplex (COM0, COM1 and COM2 are used)
- 1/4 multiplex (all COM0, COM1, COM2 and COM3 are used)

The LMUX<1:0> setting decides the function of RB5, RA2 or either RA3 or RD0 pins (see Table 9-1 for details).

If the pin is a digital I/O, the corresponding TRIS bit controls the data direction. If the pin is a COM drive, then the TRIS setting of that pin is overridden.

Note: On a Power-on Reset, the LMUX<1:0> bits are '11'.

TABLE 9-1: RA3, RA2, RB5 FUNCTION

LMUX <1:0>	RA3/RD0 ⁽¹⁾	RA2	RB5
00	Digital I/O	Digital I/O	Digital I/O
01	Digital I/O	Digital I/O	COM1 Driver
10	Digital I/O	COM2 Driver	COM1 Driver
11	COM3 Driver	COM2 Driver	COM1 Driver

Note 1: RA3 for PIC16F913/916, RD0 for PIC16F914/917

9.4 Segment Enables

The LCDSEn registers are used to select the pin function for each segment pin. The selection allows each pin to operate as either an LCD segment driver or as one of the pin's alternate functions. To configure the pin as a segment pin, the corresponding bits in the LCDSEn registers must be set to '1'.

If the pin is a digital I/O, the corresponding TRIS bit controls the data direction. Any bit set in the LCDSEn registers overrides any bit settings in the corresponding TRIS register.

Note: On a Power-on Reset, these pins are configured as digital I/O.

9.5 Pixel Control

The LCDDATAx registers contain bits which define the state of each pixel. Each bit defines one unique pixel.

Register 9-4 shows the correlation of each bit in the LCDDATAx registers to the respective common and segment signals.

Any LCD pixel location not being used for display can be used as general purpose RAM.

9.6 LCD Frame Frequency

The rate at which the COM and SEG outputs change is called the LCD frame frequency.

TABLE 9-2: FRAME FREQUENCY FORMULAS

Multiplex	Frame Frequency =
Static	Clock source/(4 x 1 x (LP<3:0> + 1))
1/2	Clock source/(2 x 2 x (LP<3:0> + 1))
1/3	Clock source/(1 x 3 x (LP<3:0> + 1))
1/4	Clock source/(1 x 4 x (LP<3:0> + 1))

Note: Clock source is Fosc/8192, T1OSC/32 or LFINTOSC/32.

TABLE 9-3: APPROXIMATE FRAME FREQUENCY (IN Hz) USING Fosc @ 8 MHz, TIMER1 @ 32.768 kHz OR INTOSC

LP<3:0>	Static	1/2	1/3	1/4
2	85	85	114	85
3	64	64	85	64
4	51	51	68	51
5	43	43	57	43
6	37	37	49	37
7	32	32	43	32

PIC16F917/916/914/913

FIGURE 9-3: LCD CLOCK GENERATION

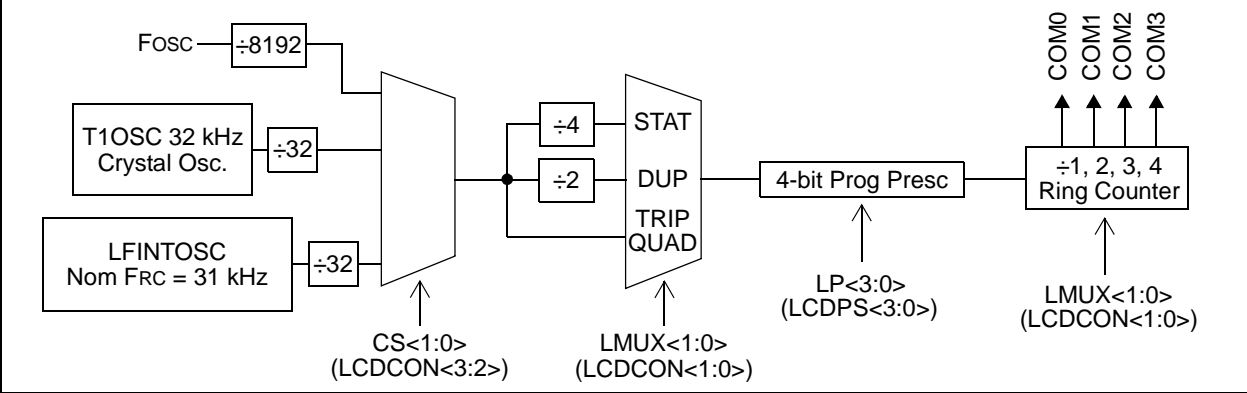

FIGURE 9-4: LCD SEGMENT MAPPING WORKSHEET

LCD Function	COM0		COM1		COM2		COM3		Pin No. 28/40-pin	PORT	Alternate Functions
	LCDDATAx Address	LCD Segment	LCDDATAx Address	LCD Segment	LCDDATAx Address	LCD Segment	LCDDATAx Address	LCD Segment			
SEG0	LCDDATA0, 0		LCDDATA3, 0		LCDDATA6, 0		LCDDATA9, 0		21/33	RB0	INT
SEG1	LCDDATA0, 1		LCDDATA3, 1		LCDDATA6, 1		LCDDATA9, 1		22/34	RB1	
SEG2	LCDDATA0, 2		LCDDATA3, 2		LCDDATA6, 2		LCDDATA9, 2		23/35	RB2	
SEG3	LCDDATA0, 3		LCDDATA3, 3		LCDDATA6, 3		LCDDATA9, 3		24/36	RB3	
SEG4	LCDDATA0, 4		LCDDATA3, 4		LCDDATA6, 4		LCDDATA9, 4		6/6	RA4	C1OUT/T0CKI
SEG5	LCDDATA0, 5		LCDDATA3, 5		LCDDATA6, 5		LCDDATA9, 5		7/7	RA5	C2OUT/AN4/SS
SEG6	LCDDATA0, 6		LCDDATA3, 6		LCDDATA6, 6		LCDDATA9, 6		14/18	RC3	
SEG7	LCDDATA0, 7		LCDDATA3, 7		LCDDATA6, 7		LCDDATA9, 7		3/3	RA1	AN1
SEG8	LCDDATA1, 0		LCDDATA4, 0		LCDDATA7, 0		LCDDATA10, 0		18/26	RC7	RX/DT/SDI/SDA
SEG9	LCDDATA1, 1		LCDDATA4, 1		LCDDATA7, 1		LCDDATA10, 1		17/25	RC6	TX/CK/SCK/SCL
SEG10	LCDDATA1, 2		LCDDATA4, 2		LCDDATA7, 2		LCDDATA10, 2		16/24	RC5	T1CKI/ICCP1
SEG11	LCDDATA1, 3		LCDDATA4, 3		LCDDATA7, 3		LCDDATA10, 3		15/23	RC4	T1G/SDO
SEG12	LCDDATA1, 4		LCDDATA4, 4		LCDDATA7, 4		LCDDATA10, 4		2/2	RA0	AN0
SEG13	LCDDATA1, 5		LCDDATA4, 5		LCDDATA7, 5		LCDDATA10, 5		28/40	RB7	ICSPDAT/ICDDAT
SEG14	LCDDATA1, 6		LCDDATA4, 6		LCDDATA7, 6		LCDDATA10, 6		27/39	RB6	ICSPCK/ICDCK
SEG15	LCDDATA1, 7		LCDDATA4, 7		LCDDATA7, 7		LCDDATA10, 7		5/5	RA3	AN3/REF+
SEG16	LCDDATA2, 0		LCDDATA5, 0		LCDDATA8, 0		LCDDATA11, 0		-/26	RD3	
SEG17	LCDDATA2, 1		LCDDATA5, 1		LCDDATA8, 1		LCDDATA11, 1		-/27	RD4	
SEG18	LCDDATA2, 2		LCDDATA5, 2		LCDDATA8, 2		LCDDATA11, 2		-/28	RD5	
SEG19	LCDDATA2, 3		LCDDATA5, 3		LCDDATA8, 3		LCDDATA11, 3		-/29	RD6	
SEG20	LCDDATA2, 4		LCDDATA5, 4		LCDDATA8, 4		LCDDATA11, 4		-/30	RD7	
SEG21	LCDDATA2, 5		LCDDATA5, 5		LCDDATA8, 5		LCDDATA11, 5		-/8	RE0	AN5
SEG22	LCDDATA2, 6		LCDDATA5, 6		LCDDATA8, 6		LCDDATA11, 6		-/9	RE1	AN6
SEG23	LCDDATA2, 7		LCDDATA5, 7		LCDDATA8, 7		LCDDATA11, 7		-/10	RE2	AN7

■ PIC16F914/917 only.

PIC16F917/916/914/913

9.7 LCD Waveform Generation

LCD waveforms are generated so that the net AC voltage across the dark pixel should be maximized and the net AC voltage across the clear pixel should be minimized. The net DC voltage across any pixel should be zero.

The COM signal represents the time slice for each common, while the SEG contains the pixel data.

The pixel signal (COM-SEG) will have no DC component and it can take only one of the two rms values. The higher rms value will create a dark pixel and a lower rms value will create a clear pixel.

As the number of commons increases, the delta between the two rms values decreases. The delta represents the maximum contrast that the display can have.

The LCDs can be driven by two types of waveform: Type-A and Type-B. In Type-A waveform, the phase changes within each common type, whereas in Type-B waveform, the phase changes on each frame boundary. Thus, Type-A waveform maintains 0 VDC over a single frame, whereas Type-B waveform takes two frames.

Note 1: If Sleep has to be executed with LCD Sleep enabled (LCDCON<SLPEN> is '1'), then care must be taken to execute Sleep only when VDC on all the pixels is '0'.

2: When the LCD clock source is Fosc/8192, if Sleep is executed, irrespective of the LCDCON<SLPEN> setting, the LCD goes into Sleep. Thus, take care to see that VDC on all pixels is '0' when Sleep is executed.

Figure 9-5 through Figure 9-15 provide waveforms for static, half-multiplex, one-third-multiplex and quarter-multiplex drives for Type-A and Type-B waveforms.

FIGURE 9-5: TYPE-A/TYPE-B WAVEFORMS IN STATIC DRIVE

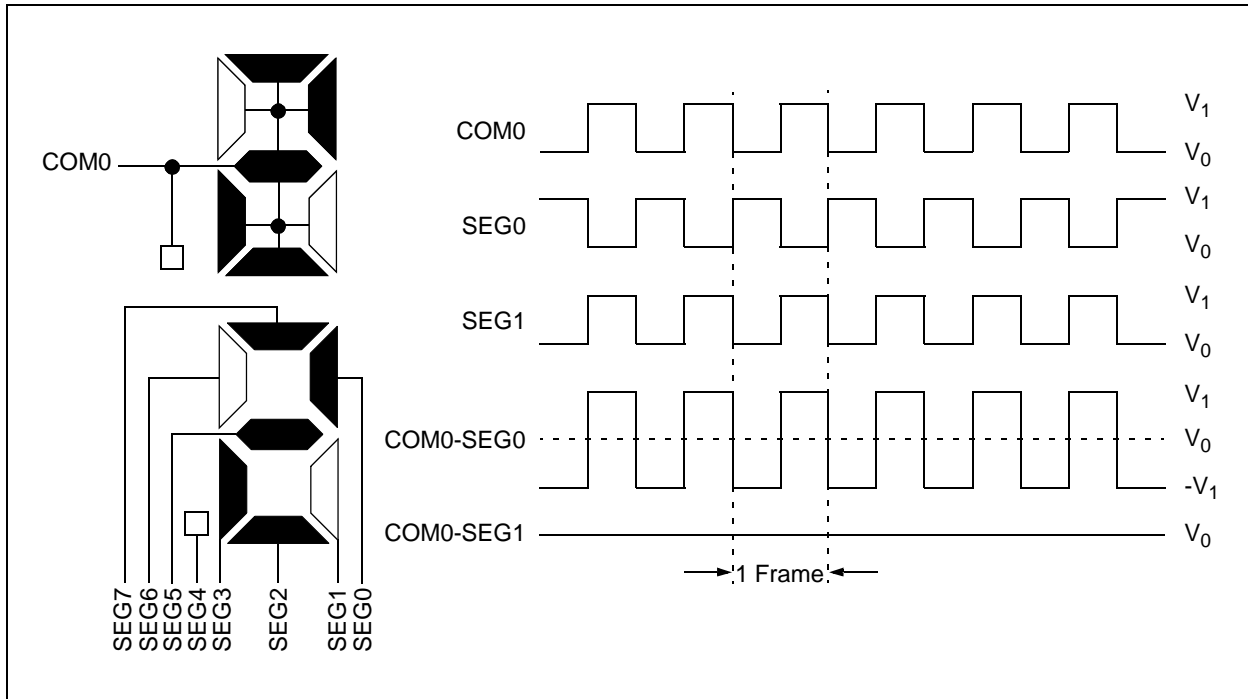
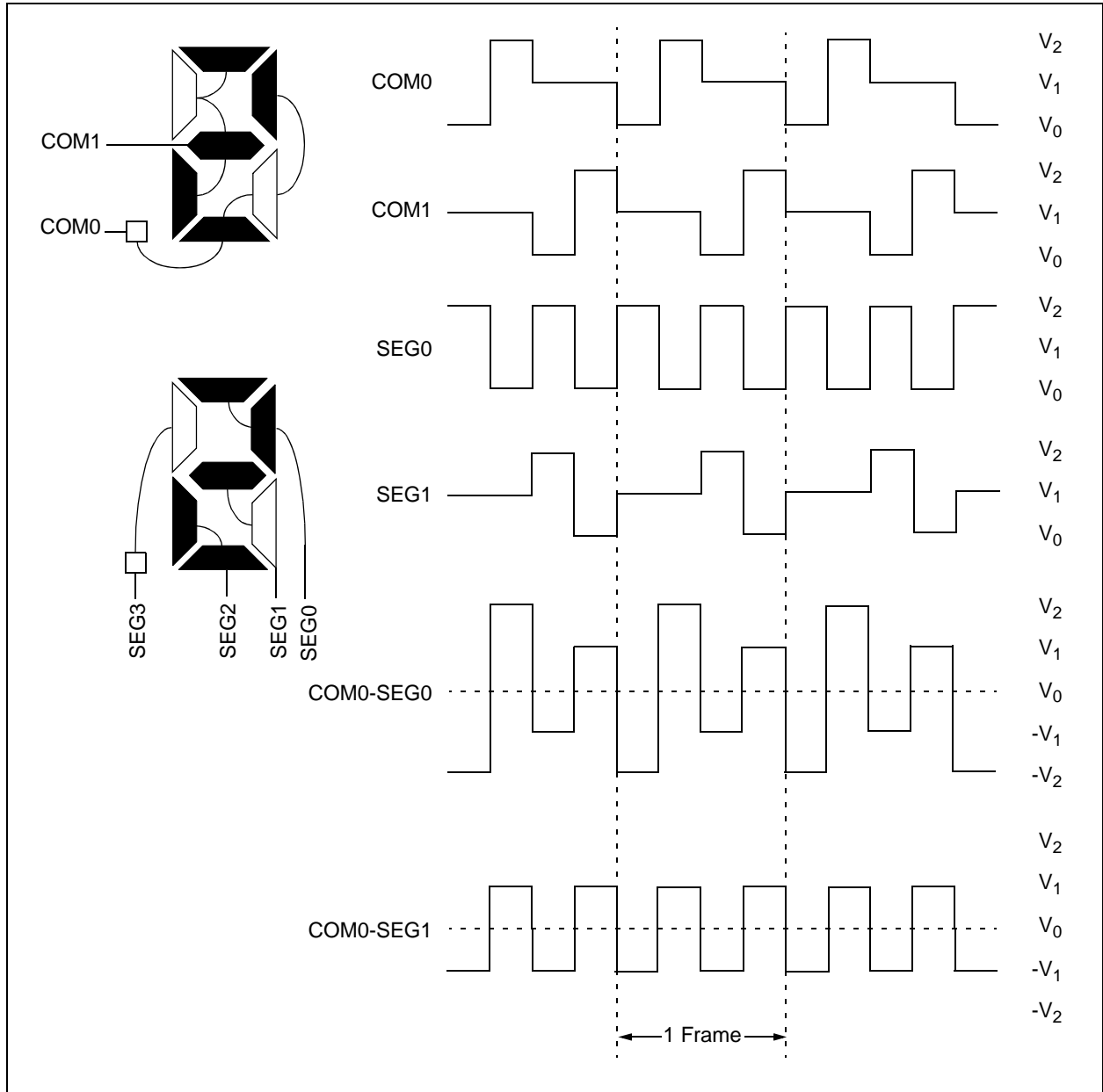

FIGURE 9-6: TYPE-A WAVEFORMS IN 1/2 MUX, 1/2 BIAS DRIVE



PIC16F917/916/914/913

FIGURE 9-7: TYPE-B WAVEFORMS IN 1/2 MUX, 1/2 BIAS DRIVE

FIGURE 9-8: TYPE-A WAVEFORMS IN 1/2 MUX, 1/3 BIAS DRIVE

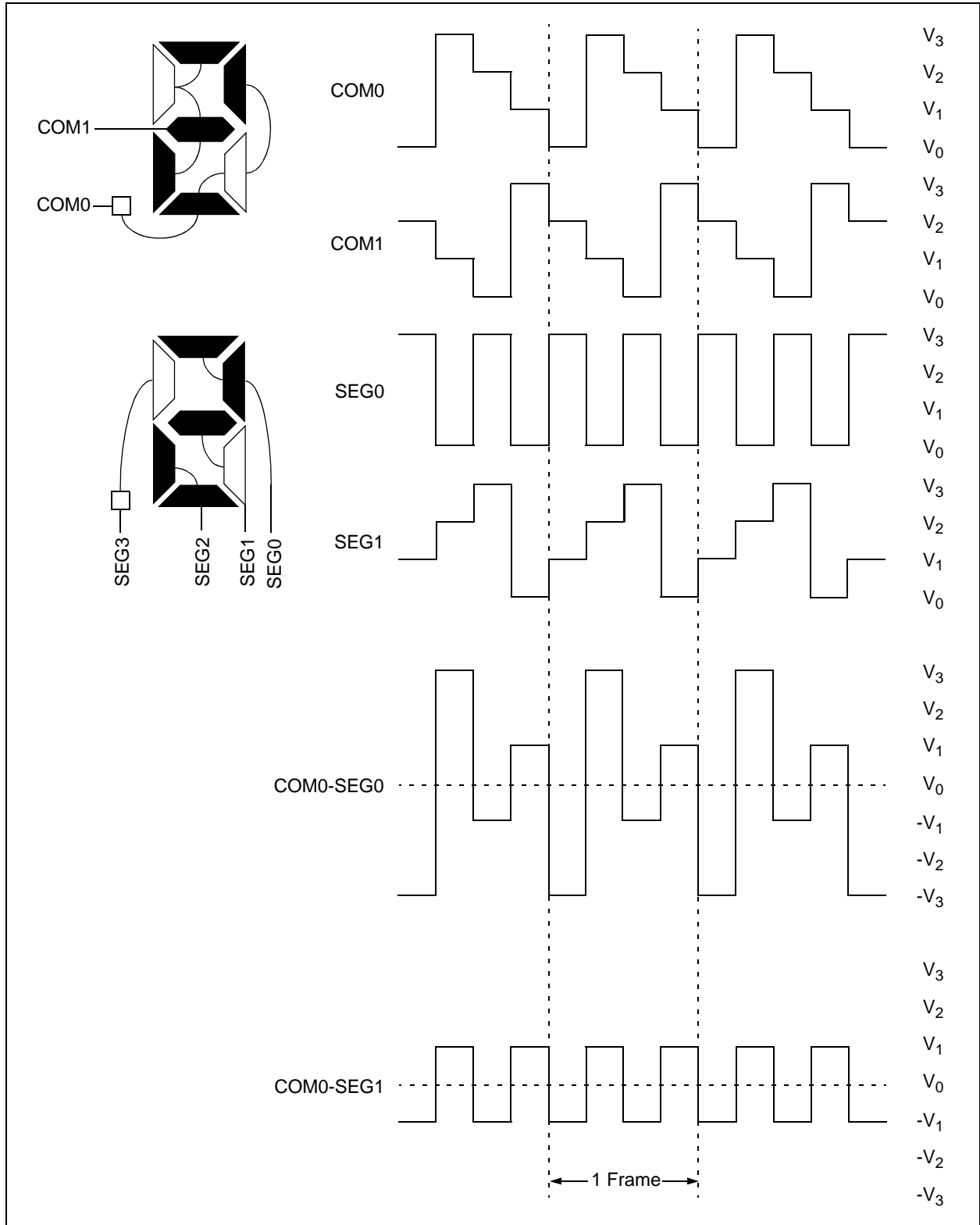

PIC16F917/916/914/913

FIGURE 9-9: TYPE-B WAVEFORMS IN 1/2 MUX, 1/3 BIAS DRIVE

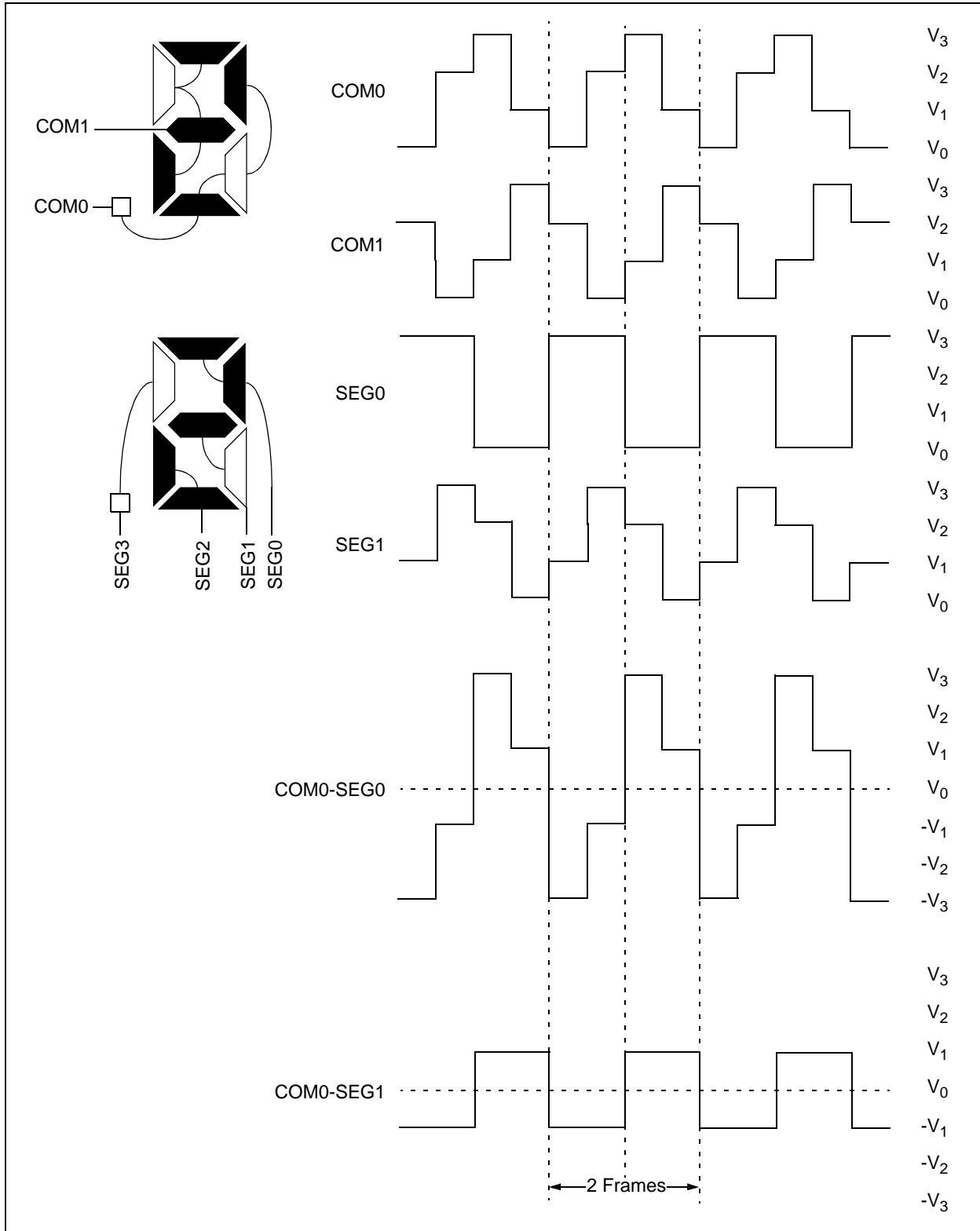
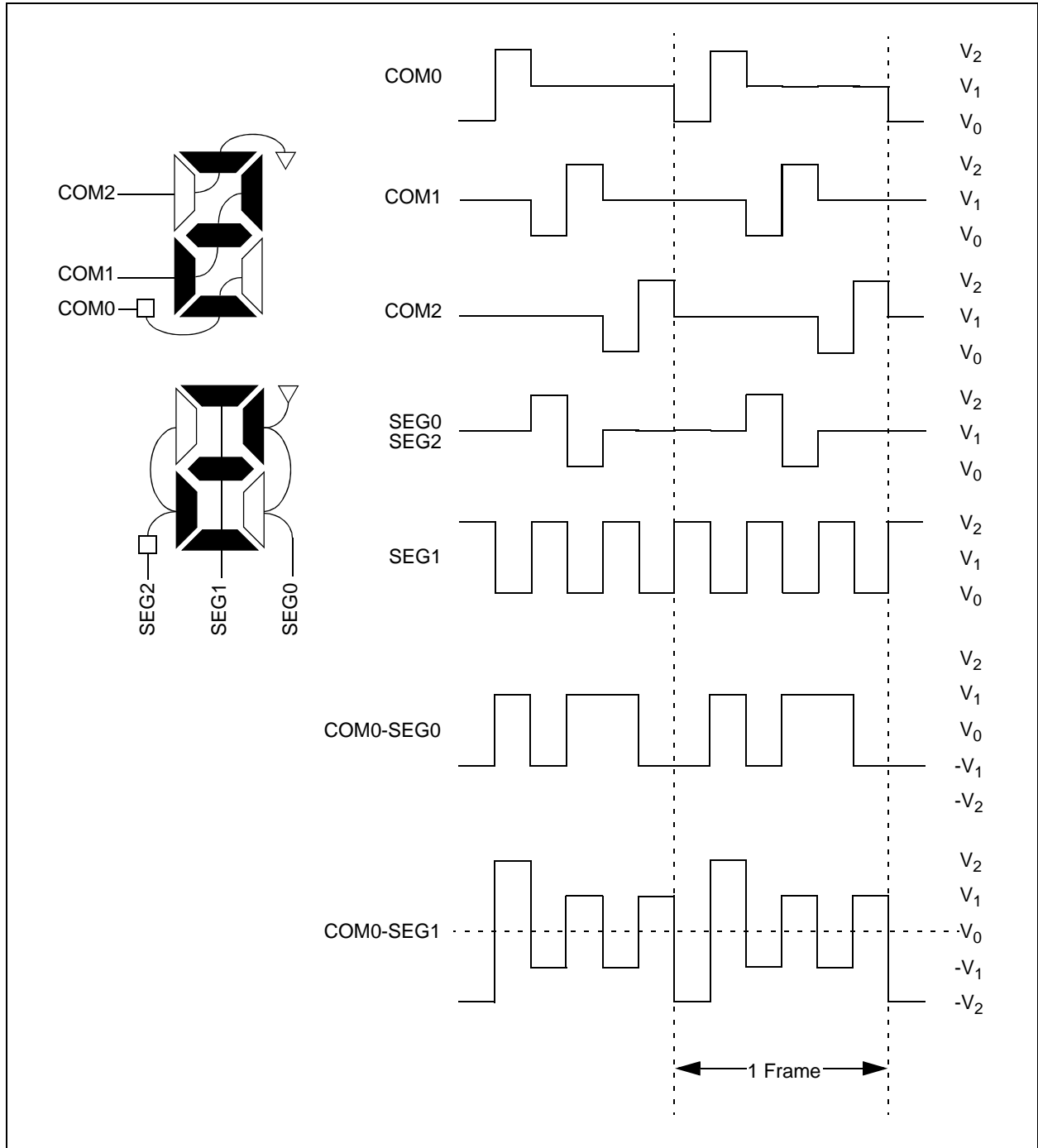

FIGURE 9-10: TYPE-A WAVEFORMS IN 1/3 MUX, 1/2 BIAS DRIVE



PIC16F917/916/914/913

FIGURE 9-11: TYPE-B WAVEFORMS IN 1/3 MUX, 1/2 BIAS DRIVE

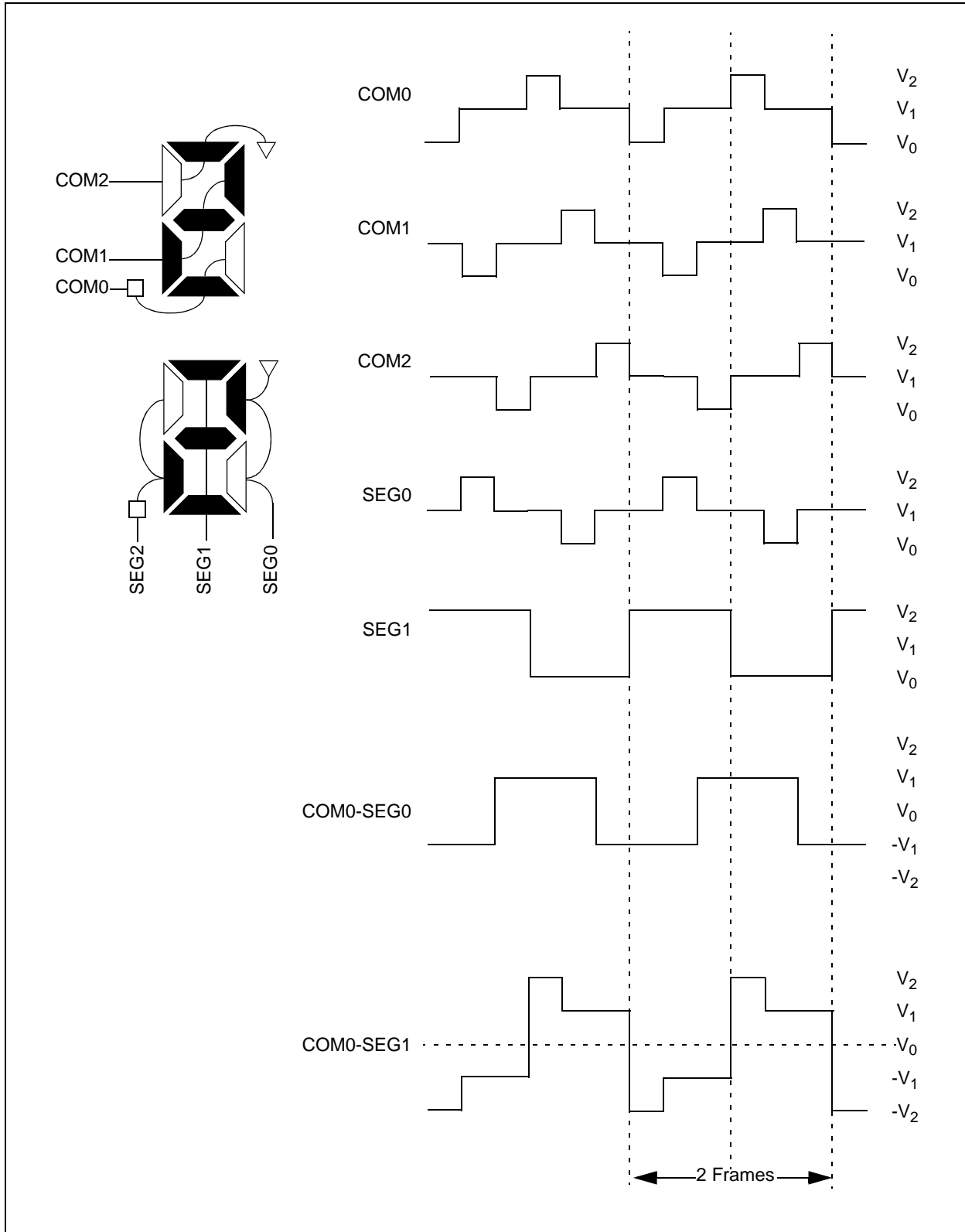
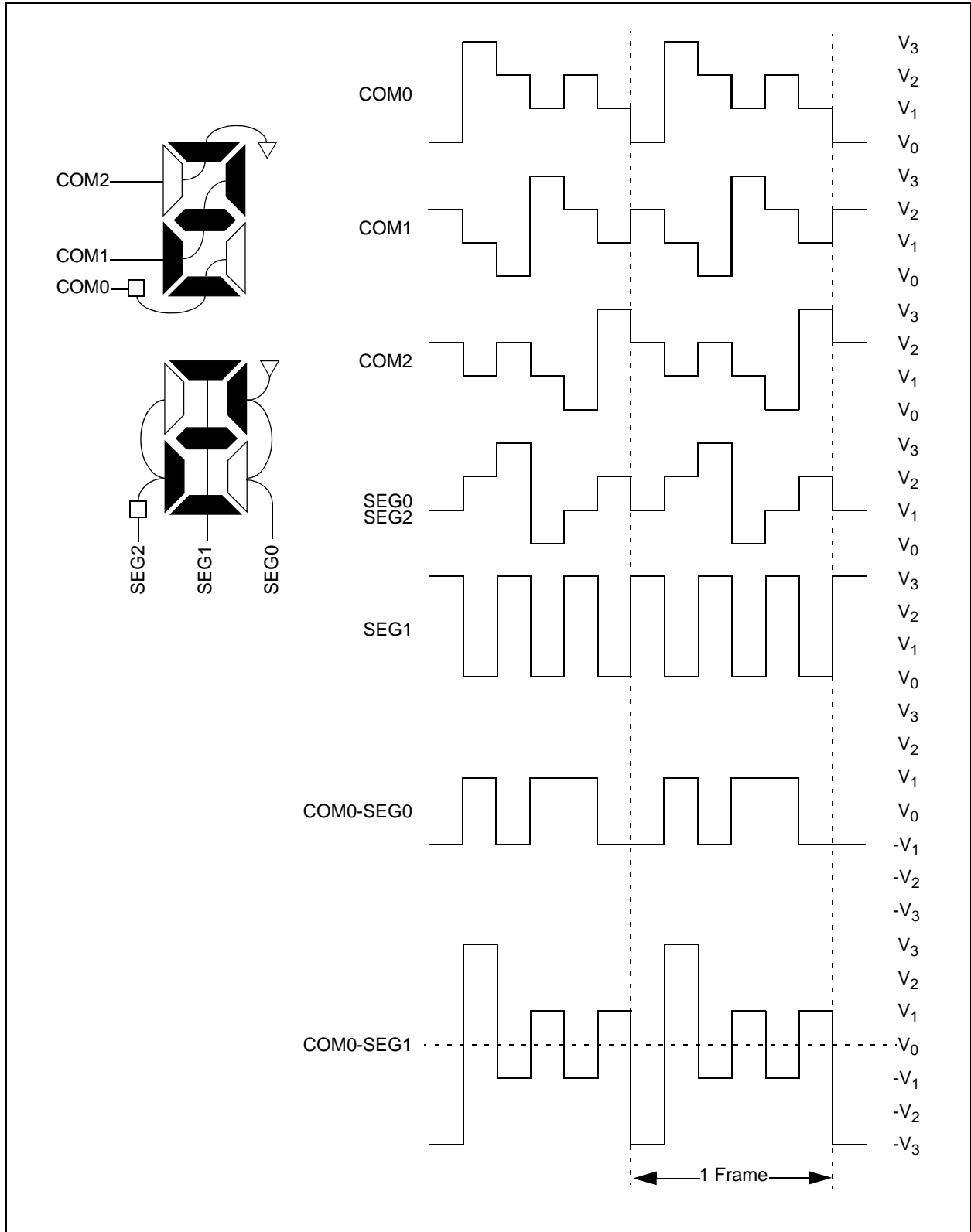

FIGURE 9-12: TYPE-A WAVEFORMS IN 1/3 MUX, 1/3 BIAS DRIVE



PIC16F917/916/914/913

FIGURE 9-13: TYPE-B WAVEFORMS IN 1/3 MUX, 1/3 BIAS DRIVE

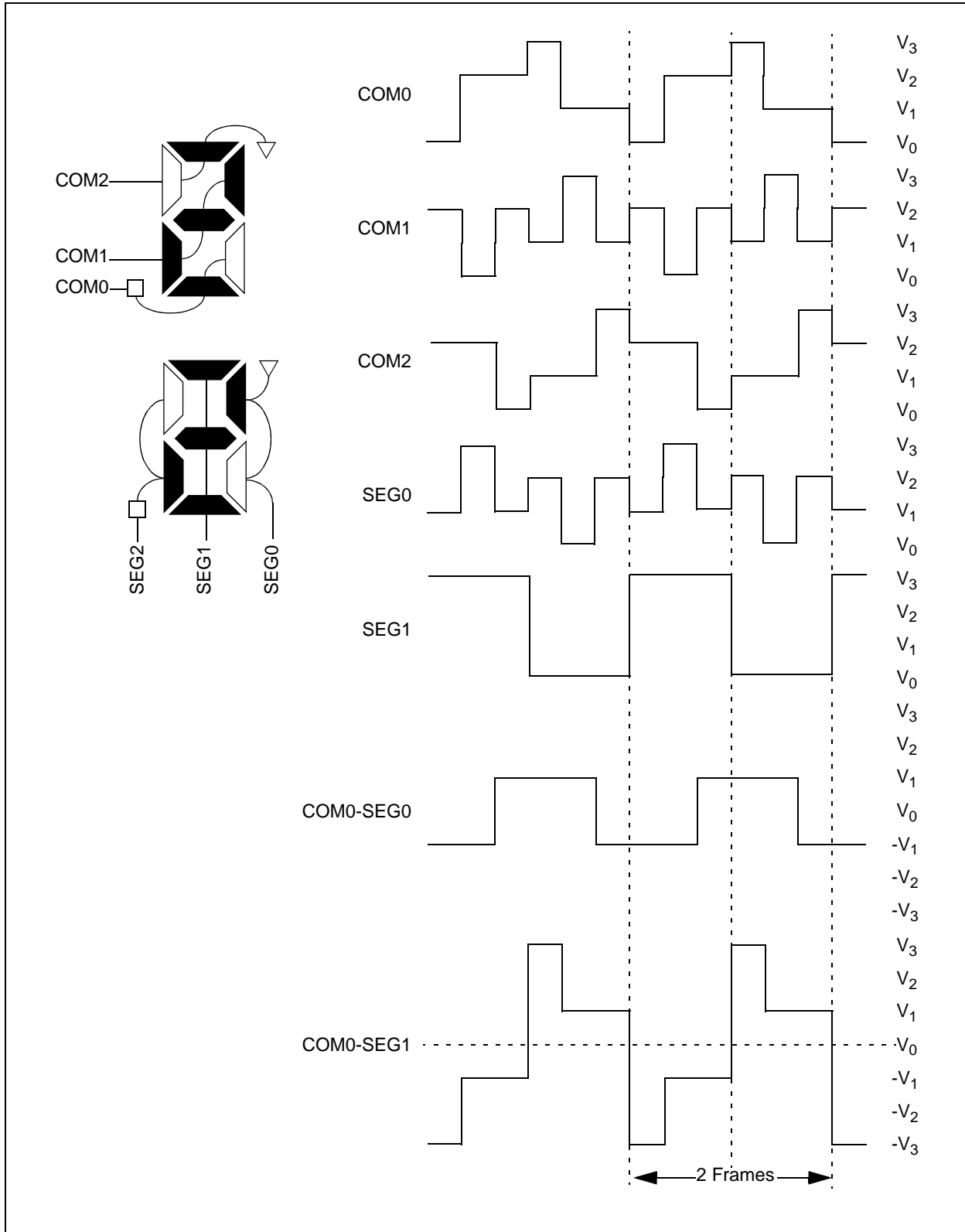
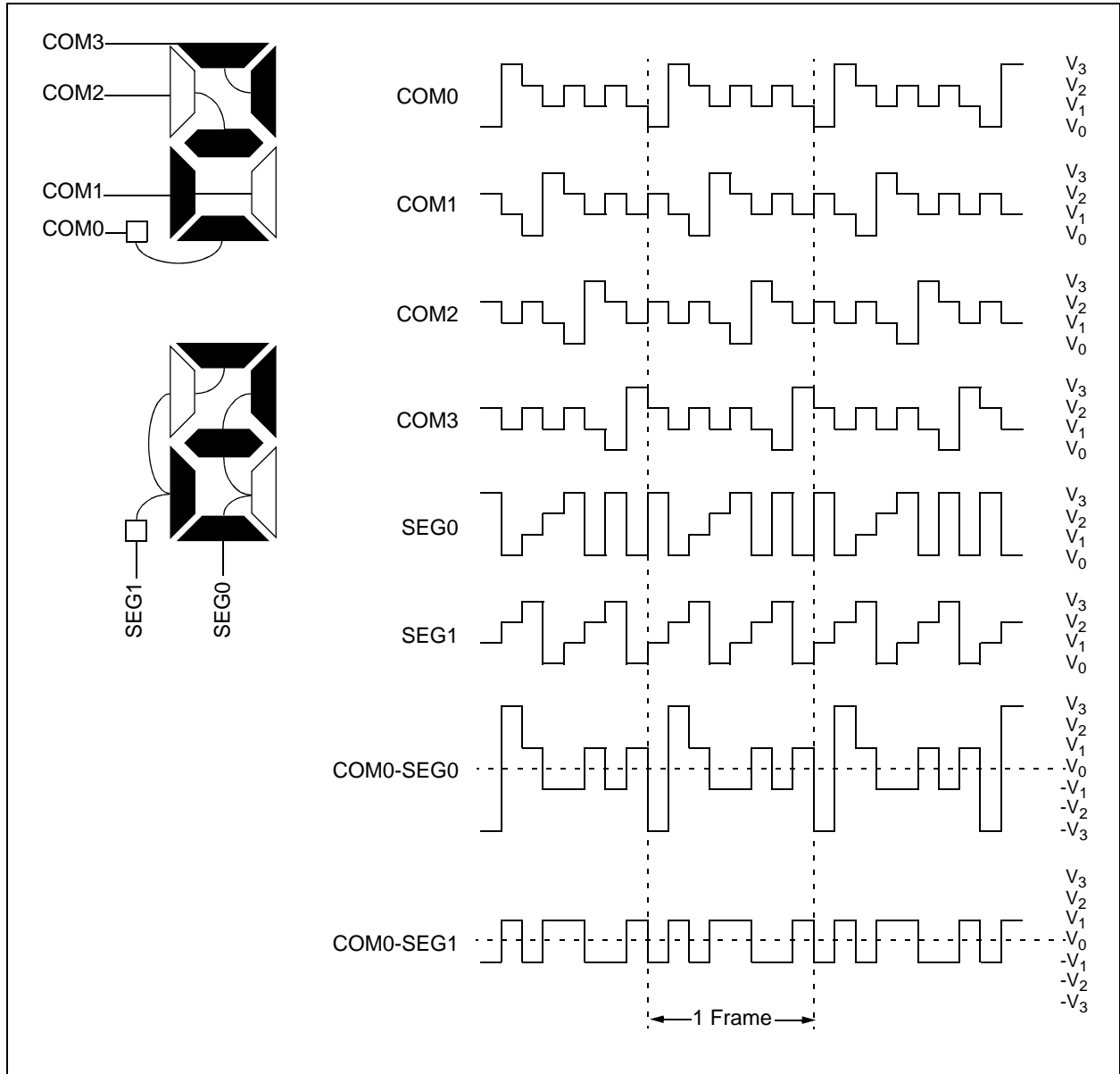
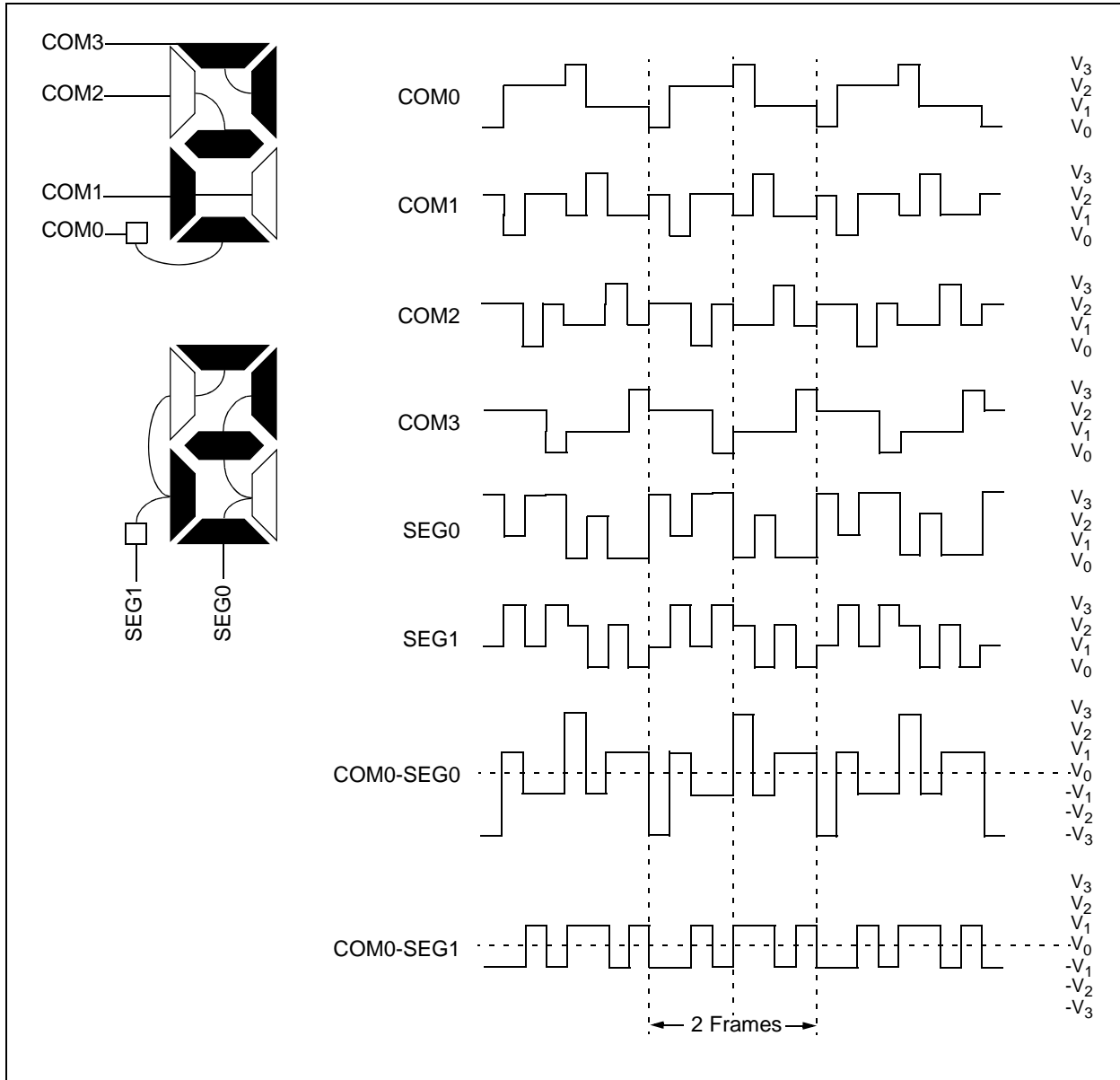

FIGURE 9-14: TYPE-A WAVEFORMS IN 1/4 MUX, 1/3 BIAS DRIVE



PIC16F917/916/914/913

FIGURE 9-15: TYPE-B WAVEFORMS IN 1/4 MUX, 1/3 BIAS DRIVE



9.8 LCD Interrupts

The LCD timing generation provides an interrupt that defines the LCD frame timing. This interrupt can be used to coordinate the writing of the pixel data with the start of a new frame. Writing pixel data at the frame boundary allows a visually crisp transition of the image. This interrupt can also be used to synchronize external events to the LCD.

A new frame is defined to begin at the leading edge of the COM0 common signal. The interrupt will be set immediately after the LCD controller completes accessing all pixel data required for a frame. This will occur at a fixed interval before the frame boundary (TFINT), as shown in Figure 9-16. The LCD controller will begin to access data for the next frame within the interval from the interrupt to when the controller begins to access data after the interrupt (TFWR). New data must be written within TFWR, as this is when the LCD controller will begin to access the data for the next frame.

When the LCD driver is running with Type-B waveforms and the LMUX<1:0> bits are not equal to '00', there are some additional issues that must be addressed. Since the DC voltage on the pixel takes two frames to maintain zero volts, the pixel data must not change between subsequent frames. If the pixel data were allowed to change, the waveform for the odd frames would not necessarily be the complement of the waveform generated in the even frames and a DC component would be introduced into the panel. Therefore, when using Type-B waveforms, the user must synchronize the LCD pixel updates to occur within a subframe after the frame interrupt.

To correctly sequence writing while in Type-B, the interrupt will only occur on complete phase intervals. If the user attempts to write when the write is disabled, the WERR (LCDCON<5>) bit is set.

Note: The interrupt is not generated when the Type-A waveform is selected and when the Type-B with no multiplex (static) is selected.

FIGURE 9-16: WAVEFORMS AND INTERRUPT TIMING IN QUARTER-DUTY CYCLE DRIVE (EXAMPLE – TYPE-B, NON-STATIC)

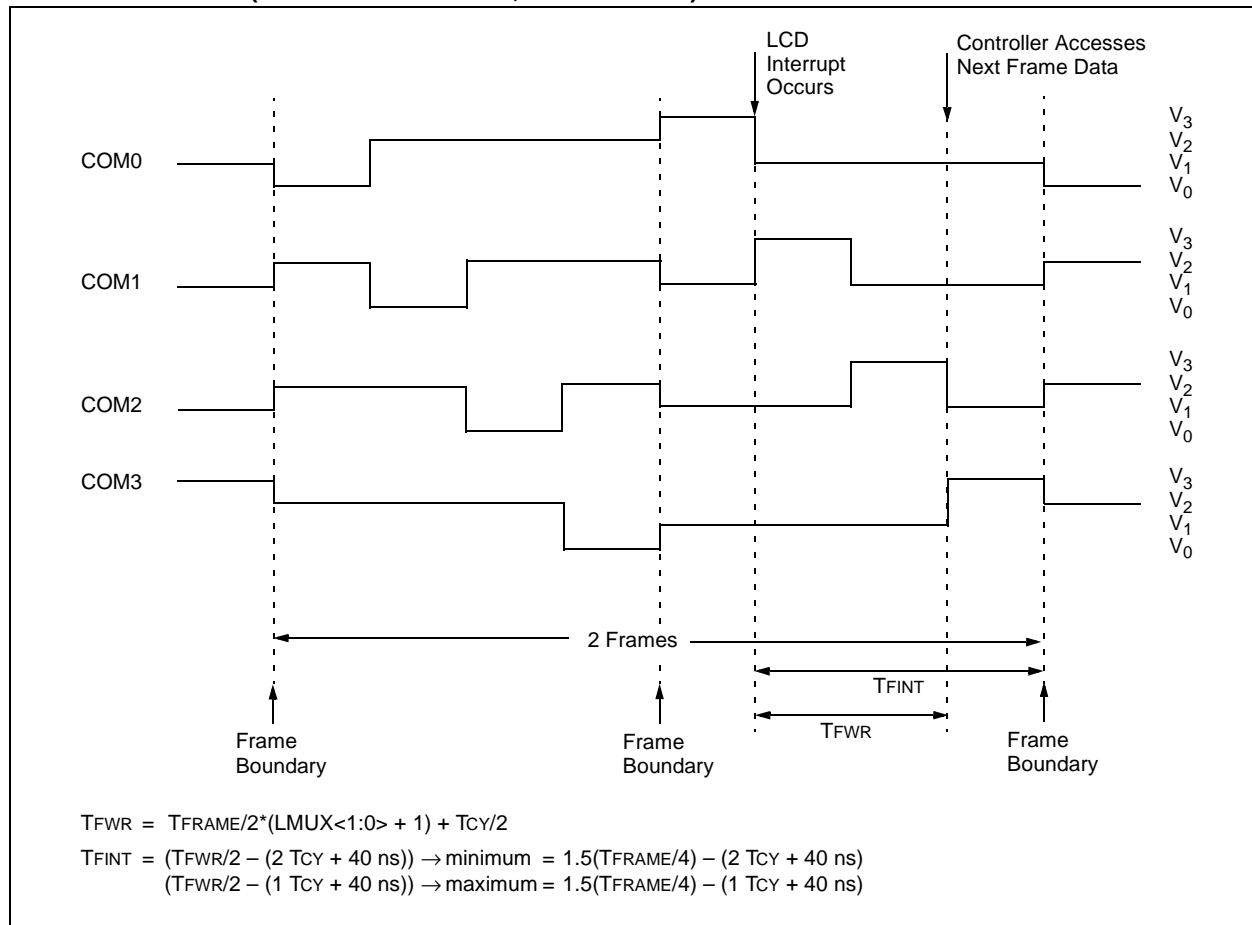

PIC16F917/916/914/913

9.9 Operation During Sleep

The LCD module can operate during Sleep. The selection is controlled by bit SLPEN (LCDCON<6>). Setting the SLPEN bit allows the LCD module to go to Sleep. Clearing the SLPEN bit allows the module to continue to operate during Sleep.

If a SLEEP instruction is executed and SLPEN = 1, the LCD module will cease all functions and go into a very low-current Consumption mode. The module will stop operation immediately and drive the minimum LCD voltage on both segment and common lines. Figure 9-17 shows this operation.

To ensure that no DC component is introduced on the panel, the SLEEP instruction should be executed immediately after a LCD frame boundary. The LCD interrupt can be used to determine the frame boundary. See **Section 9.8 “LCD Interrupts”** for the formulas to calculate the delay.

If a SLEEP instruction is executed and SLPEN = 0, the module will continue to display the current contents of the LCDDATA registers. To allow the module to continue operation while in Sleep, the clock source must be either the LFINTOSC or T1OSC external oscillator. While in Sleep, the LCD data cannot be changed. The LCD module current consumption will not decrease in this mode; however, the overall consumption of the device will be lower due to shut down of the core and other peripheral functions.

Table 9-4 shows the status of the LCD module during a Sleep while using each of the three available clock sources:

TABLE 9-4: LCD MODULE STATUS DURING SLEEP

Clock Source	SLPEN	Operation During Sleep?
T1OSC	0	Yes
	1	No
LFINTOSC	0	Yes
	1	No
Fosc/4	0	No
	1	No

Note: The LFINTOSC or external T1OSC oscillator must be used to operate the LCD module during Sleep.

FIGURE 9-17: SLEEP ENTRY/EXIT WHEN SLPEN = 1 OR CS<1:0> = 00

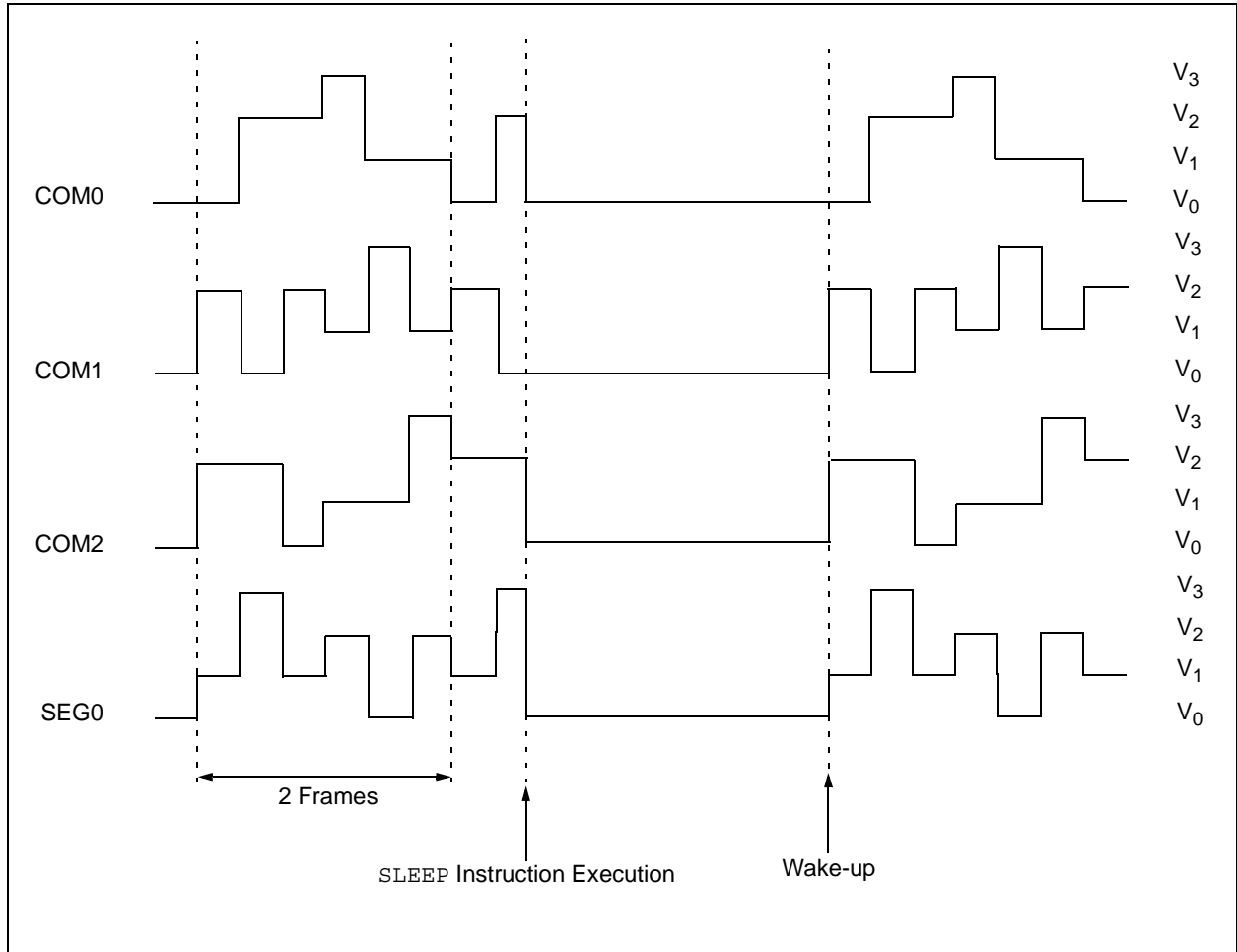

PIC16F917/916/914/913

9.10 Configuring the LCD Module

The following is the sequence of steps to configure the LCD module.

1. Select the frame clock prescale using bits LP<3:0> (LCDPS<3:0>).
2. Configure the appropriate pins to function as segment drivers using the LCDSEn registers.
3. Configure the LCD module for the following using the LCDCON register:
 - Multiplex and Bias mode, bits LMUX<1:0>
 - Timing source, bits CS<1:0>
 - Sleep mode, bit SLPEN
4. Write initial values to pixel data registers, LCDDATA0 through LCDDATA11.
5. Clear LCD Interrupt Flag, LCDIF (PIR2<4>) and if desired, enable the interrupt by setting bit LCDIE (PIE2<4>).
6. Enable bias voltage pins (VLCD<3:1>) by setting VLCDEN (LCDCON<4>).
7. Enable the LCD module by setting bit LCDEN (LCDCON<7>).

TABLE 9-5: REGISTERS ASSOCIATED WITH LCD OPERATION

Address	Name	Bit 7	Bit 6	Bit 5	Bit 4	Bit 3	Bit 2	Bit 1	Bit 0	Value on POR, BOR	Value on all other Resets
10h	T1CON	T1GINV	T1GE	T1CKPS1	T1CKPS0	T1OSCEN	T1SYNC	TMR1CS	TMR1ON	0000 0000	uuuu uuuu
0Bh/8Bh/ 10Bh/18Bh	INTCON	GIE	PEIE	T0IE	INTE	RBIE	T0IF		RBIF	0000 000x	0000 000x
0Dh	PIR2		JIF00								

10.0 PROGRAMMABLE LOW-VOLTAGE DETECT (PLVD) MODULE

The Programmable Low-Voltage Detect module is an interrupt driven supply level detection. The voltage detection monitors the internal power supply.

10.1.1 PLVD CALIBRATION

The PIC16F91X stores the PLVD calibration values in fuses located in the Calibration Word 2 (2009h). The Calibration Word 2 is not erased when using the specified bulk erase sequence in the "PIC16F91X *Memory Programming Specification*" (DS41244) and thus, does not require reprogramming.

10.1 Voltage Trip Points

The PIC16F917/916/914/913 device supports eight internal PLVD trip points. See Register 10-1 for available PLVD trip point voltages.

REGISTER 10-1: LVDCON – LOW-VOLTAGE DETECT CONTROL REGISTER (ADDRESS: 109h)

U-0	U-0	R-0	R/W-0	U-0	R/W-1	R/W-0	R/W-0
—	—	IRVST	LVDCON	—	LVDL2	LVDL1	LVDL0
bit 7				bit 0			

bit 7-6 **Unimplemented:** Read as '0'

bit 5 **IRVST:** Internal Reference Voltage Stable Status Flag bit⁽¹⁾

1 = Indicates that the PLVD is stable and PLVD interrupt is reliable

0 = Indicates that the PLVD is not stable and PLVD interrupt should not be enabled

bit 4 **LVDCON:** Low-Voltage Detect Power Enable bit

1 = Enables PLVD, powers up PLVD circuit and supporting reference circuitry

0 = Disables PLVD, powers down PLVD and supporting circuitry

bit 3 **Unimplemented:** Read as '0'

bit 2-0 **LVDL<2:0>:** Low-Voltage Detection Limit bits (nominal values)

111 = 4.5V

110 = 4.2V

101 = 4.0V

100 = 2.3V (default)

011 = 2.2V

010 = 2.1V

001 = 2.0V

000 = 1.9V⁽²⁾

Note 1: The IRVST bit is usable only when the HFINTOSC is running. When using an external crystal to run the microcontroller, the PLVD settling time is expected to be <50 μ s when $V_{DD} = 5V$ and <25 μ s when $V_{DD} = 3V$. Appropriate software delays should be used after enabling the PLVD module to ensure proper status readings of the module.

2: Not tested and below minimum V_{DD} .

Legend:

R = Readable bit

W = Writable bit

U = Unimplemented bit, read as '0'

- n = Value at POR

'1' = Bit is set

'0' = Bit is cleared

x = Bit is unknown

11.0 ADDRESSABLE UNIVERSAL SYNCHRONOUS ASYNCHRONOUS RECEIVER TRANSMITTER (USART)

The Universal Synchronous Asynchronous Receiver Transmitter (USART) module is one of the two serial I/O modules. (USART is also known as a Serial Communications Interface or SCI.) The USART can be configured as a full-duplex asynchronous system that can communicate with peripheral devices, such as CRT terminals and personal computers, or it can be configured as a half-duplex synchronous system that can communicate with peripheral devices, such as A/D or D/A integrated circuits, serial EEPROMs, etc.

The USART can be configured in the following modes:

- Asynchronous (full-duplex)
- Synchronous – Master (half-duplex)
- Synchronous – Slave (half-duplex)

Bit SPEN (RCSTA<7>) and bits TRISC<7:6> have to be set in order to configure pins RC6/TX/CK/SCK/SCL/SEG9 and RC7/RX/DT/SDI/SDA/SEG8 as the Universal Synchronous Asynchronous Receiver Transmitter.

The USART module also has a multi-processor communication capability using 9-bit address detection.

REGISTER 11-1: TXSTA – TRANSMIT STATUS AND CONTROL REGISTER (ADDRESS 98h)

R/W-0	R/W-0	R/W-0	R/W-0	U-0	R/W-0	R-1	R/W-0
CSRC	TX9	TXEN	SYNC	—	BRGH	TRMT	TX9D
						bit 7	bit 0

- bit 7 **CSRC:** Clock Source Select bit
Asynchronous mode:
 Don't care
Synchronous mode:
 1 = Master mode (clock generated internally from BRG)
 0 = Slave mode (clock from external source)
- bit 6 **TX9:** 9-bit Transmit Enable bit
 1 = Selects 9-bit transmission
 0 = Selects 8-bit transmission
- bit 5 **TXEN:** Transmit Enable bit
 1 = Transmit enabled
 0 = Transmit disabled
Note: SREN/CREN overrides TXEN in Sync mode.
- bit 4 **SYNC:** USART Mode Select bit
 1 = Synchronous mode
 0 = Asynchronous mode
- bit 3 **Unimplemented:** Read as '0'
- bit 2 **BRGH:** High Baud Rate Select bit
Asynchronous mode:
 1 = High speed
 0 = Low speed
Synchronous mode:
 Unused in this mode
- bit 1 **TRMT:** Transmit Shift Register Status bit
 1 = TSR empty
 0 = TSR full
- bit 0 **TX9D:** 9th bit of Transmit Data, can be Parity bit

Legend:

R = Readable bit	W = Writable bit	U = Unimplemented bit, read as '0'
- n = Value at POR	'1' = Bit is set	'0' = Bit is cleared x = Bit is unknown

PIC16F917/916/914/913

REGISTER 11-2: RCSTA – RECEIVE STATUS AND CONTROL REGISTER (ADDRESS 18h)

R/W-0	R/W-0	R/W-0	R/W-0	R/W-0	R-0	R-0	R-x
SPEN	RX9	SREN	CREN	ADDEN	FERR	OERR	RX9D
bit 7						bit 0	

- bit 7 **SPEN⁽¹⁾**: Serial Port Enable bit
1 = Serial port enabled (configures RC7/RX/DT/SDI/SDA/SEG8 and RC6/TX/CK/SCK/SCL/SEG9 pins as serial port pins)
0 = Serial port disabled
- bit 6 **RX9**: 9-bit Receive Enable bit
1 = Selects 9-bit reception
0 = Selects 8-bit reception
- bit 5 **SREN**: Single Receive Enable bit
Asynchronous mode:
Don't care
Synchronous mode – Master:
1 = Enables single receive
0 = Disables single receive
This bit is cleared after reception is complete
Synchronous mode – Slave:
Don't care.
- bit 4 **CREN**: Continuous Receive Enable bit
Asynchronous mode:
1 = Enables continuous receive
0 = Disables continuous receive
Synchronous mode:
1 = Enables continuous receive until enable bit CREN is cleared (CREN overrides SREN)
0 = Disables continuous receive
- bit 3 **ADDEN**: Address Detect Enable bit
Asynchronous mode 9-bit (RX9 = 1):
1 = Enables address detection, enables interrupt and load of the receive buffer when RSR<8> is set
0 = Disables address detection, all bytes are received and ninth bit can be used as parity bit
- bit 2 **FERR**: Framing Error bit
1 = Framing error (can be updated by reading RCREG register and receive next valid byte)
0 = No framing error
- bit 1 **OERR**: Overrun Error bit
1 = Overrun error (can be cleared by clearing bit CREN)
0 = No overrun error
- bit 0 **RX9D**: 9th bit of Received Data (can be parity bit but must be calculated by user firmware)

Note 1: CCP2CON used for PIC16F914/917 only.

Legend:			
R = Readable bit	W = Writable bit	U = Unimplemented bit, read as '0'	
- n = Value at POR	'1' = Bit is set	'0' = Bit is cleared	x = Bit is unknown

11.1 USART Baud Rate Generator (BRG)

The BRG supports both the Asynchronous and Synchronous modes of the USART. It is a dedicated 8-bit baud rate generator. The SPBRG register controls the period of a free running 8-bit timer. In Asynchronous mode, bit BRGH (TXSTA<2>) also controls the baud rate. In Synchronous mode, bit BRGH is ignored. Table 11-1 shows the formula for computation of the baud rate for different USART modes which only apply in Master mode (internal clock).

Given the desired baud rate and FOSC, the nearest integer value for the SPBRG register can be calculated using the formula in Table 11-1. From this, the error in baud rate can be determined.

It may be advantageous to use the high baud rate (BRGH = 1) even for slower baud clocks. This is because the $F_{OSC}/(16(X+1))$ equation can reduce the baud rate error in some cases.

Writing a new value to the SPBRG register causes the BRG timer to be reset (or cleared). This ensures the BRG does not wait for a timer overflow before outputting the new baud rate.

11.1.1 SAMPLING

The data on the RC7/RX/DT/SDI/SDA/SEG8 pin is sampled three times by a majority detect circuit to determine if a high or a low level is present at the RX pin.

TABLE 11-1: BAUD RATE FORMULA

SYNC	BRGH = 0 (Low Speed)	BRGH = 1 (High Speed)
0	(Asynchronous) Baud Rate = $F_{OSC}/(64(X+1))$	Baud Rate = $F_{OSC}/(16(X+1))$
1	(Synchronous) Baud Rate = $F_{OSC}/(4(X+1))$	N/A

Legend: X = value in SPBRG (0 to 255)

TABLE 11-2: REGISTERS ASSOCIATED WITH BAUD RATE GENERATOR

Address	Name	Bit 7	Bit 6	Bit 5	Bit 4	Bit 3	Bit 2	Bit 1	Bit 0	Value on: POR, BOR	Value on all other Resets
98h	TXSTA	CSRC	TX9	TXEN	SYNC	—	BRGH	TRMT	TX9D	0000 -010	0000 -010
18h	RCSTA	SPEN	RX9	SREN	CREN	ADDEN	FERR	OERR	RX9D	0000 000x	0000 000x
99h	SPBRG	Baud Rate Generator Register								0000 0000	0000 0000

Legend: x = unknown, - = unimplemented, read as '0'. Shaded cells are not used by the BRG.

PIC16F917/916/914/913

TABLE 11-3: BAUD RATES FOR ASYNCHRONOUS MODE (BRGH = 0)

BAUD RATE (K)	Fosc = 20 MHz			Fosc = 16 MHz			Fosc = 10 MHz		
	KBAUD	% ERROR	SPBRG value (decimal)	KBAUD	% ERROR	SPBRG value (decimal)	KBAUD	% ERROR	SPBRG value (decimal)
0.3	—	—	—	—	—	—	—	—	—
1.2	1.221	1.75	255	1.202	0.17	207	1.202	0.17	129
2.4	2.404	0.17	129	2.404	0.17	103	2.404	0.17	64
9.6	9.766	1.73	31	9.615	0.16	25	9.766	1.73	15
19.2	19.531	1.72	15	19.231	0.16	12	19.531	1.72	7
28.8	31.250	8.51	9	27.778	3.55	8	31.250	8.51	4
33.6	34.722	3.34	8	35.714	6.29	6	31.250	6.99	4
57.6	62.500	8.51	4	62.500	8.51	3	52.083	9.58	2
HIGH	1.221	—	255	0.977	—	255	0.610	—	255
LOW	312.500	—	0	250.000	—	0	156.250	—	0

BAUD RATE (K)	Fosc = 4 MHz			Fosc = 3.6864 MHz		
	KBAUD	% ERROR	SPBRG value (decimal)	KBAUD	% ERROR	SPBRG value (decimal)
0.3	0.300	0	207	0.3	0	191
1.2	1.202	0.17	51	1.2	0	47
2.4	2.404	0.17	25	2.4	0	23
9.6	8.929	6.99	6	9.6	0	5
19.2	20.833	8.51	2	19.2	0	2
28.8	31.250	8.51	1	28.8	0	1
33.6	—	—	—	—	—	—
57.6	62.500	8.51	0	57.6	0	0
HIGH	0.244	—	255	0.225	—	255
LOW	62.500	—	0	57.6	—	0

TABLE 11-4: BAUD RATES FOR ASYNCHRONOUS MODE (BRGH = 1)

BAUD RATE (K)	Fosc = 20 MHz			Fosc = 16 MHz			Fosc = 10 MHz		
	KBAUD	% ERROR	SPBRG value (decimal)	KBAUD	% ERROR	SPBRG value (decimal)	KBAUD	% ERROR	SPBRG value (decimal)
0.3	—	—	—	—	—	—	—	—	—
1.2	—	—	—	—	—	—	—	—	—
2.4	—	—	—	—	—	—	2.441	1.71	255
9.6	9.615	0.16	129	9.615	0.16	103	9.615	0.16	64
19.2	19.231	0.16	64	19.231	0.16	51	19.531	1.72	31
28.8	29.070	0.94	42	29.412	2.13	33	28.409	1.36	21
33.6	33.784	0.55	36	33.333	0.79	29	32.895	2.10	18
57.6	59.524	3.34	20	58.824	2.13	16	56.818	1.36	10
HIGH	4.883	—	255	3.906	—	255	2.441	-	255
LOW	1250.000	—	0	1000.000	—	0	625.000	-	0

BAUD RATE (K)	Fosc = 4 MHz			Fosc = 3.6864 MHz		
	KBAUD	% ERROR	SPBRG value (decimal)	KBAUD	% ERROR	SPBRG value (decimal)
0.3	—	—	—	—	—	—
1.2	1.202	0.17	207	1.2	0	191
2.4	2.404	0.17	103	2.4	0	95
9.6	9.615	0.16	25	9.6	0	23
19.2	19.231	0.16	12	19.2	0	11
28.8	27.798	3.55	8	28.8	0	7
33.6	35.714	6.29	6	32.9	2.04	6
57.6	62.500	8.51	3	57.6	0	3
HIGH	0.977	—	255	0.9	—	255
LOW	250.000	—	0	230.4	—	0

11.2 USART Asynchronous Mode

In this mode, the USART uses standard Non-Return-to-Zero (NRZ) format (one Start bit, eight or nine data bits and one Stop bit). The most common data format is 8 bits. An on-chip, dedicated, 8-bit Baud Rate Generator can be used to derive standard baud rate frequencies from the oscillator. The USART transmits and receives the LSb first. The transmitter and receiver are functionally independent but use the same data format and baud rate. The baud rate generator produces a clock, either x16 or x64 of the bit shift rate, depending on bit BRGH (TXSTA<2>). Parity is not supported by the hardware, but can be implemented in software (and stored as the ninth data bit). Asynchronous mode is stopped during Sleep.

Asynchronous mode is selected by clearing bit SYNC (TXSTA<4>).

The USART Asynchronous module consists of the following important elements:

- Baud Rate Generator
- Sampling Circuit
- Asynchronous Transmitter
- Asynchronous Receiver

11.2.1 USART ASYNCHRONOUS TRANSMITTER

The USART transmitter block diagram is shown in Figure 11-1. The heart of the transmitter is the Transmit (Serial) Shift Register (TSR). The shift register obtains its data from the Read/Write Transmit Buffer, TXREG. The TXREG register is loaded with data in software. The TSR register is not loaded until the Stop bit has been transmitted from the previous load. As soon as the Stop bit is transmitted, the TSR is loaded with new data from the TXREG register (if available). Once the TXREG register transfers the data to the TSR register (occurs in one T_{cy}), the TXREG register is empty and flag bit, TXIF (PIR1<4>), is set. This interrupt can be enabled/disabled by setting/clearing enable bit, TXIE (PIE1<4>). Flag bit TXIF will be set regardless of the state of enable bit TXIE and cannot be cleared in software. It will reset only when new data is loaded into the TXREG register. While flag bit TXIF indicates the status of the TXREG register, another bit, TRMT (TXSTA<1>), shows the status of the TSR register. Status bit TRMT is a read-only bit which is set when the TSR register is empty. No interrupt logic is tied to this bit so the user has to poll this bit in order to determine if the TSR register is empty.

Transmission is enabled by setting enable bit, TXEN (TXSTA<5>). The actual transmission will not occur until the TXREG register has been loaded with data and the Baud Rate Generator (BRG) has produced a shift clock (Figure 11-2). The transmission can also be started by first loading the TXREG register and then setting enable bit TXEN. Normally, when transmission is first started, the TSR register is empty. At that point, transfer to the TXREG register will result in an immediate transfer to TSR, resulting in an empty TXREG. A back-to-back transfer is thus possible (Figure 11-3). Clearing enable bit TXEN during a transmission will cause the transmission to be aborted and will reset the transmitter. As a result, the RC6/TX/CK/SCK/SCL/SEG9 pin will revert to high-impedance.

In order to select 9-bit transmission, transmit bit TX9 (TXSTA<6>) should be set and the ninth bit should be written to TX9D (TXSTA<0>). The ninth bit must be written before writing the 8-bit data to the TXREG register. This is because a data write to the TXREG register can result in an immediate transfer of the data to the TSR register (if the TSR is empty). In such a case, an incorrect ninth data bit may be loaded in the TSR register.

When setting up an Asynchronous Transmission, follow these steps:

1. Initialize the SPBRG register for the appropriate baud rate. If a high-speed baud rate is desired, set bit BRGH (**Section 11.1 “USART Baud Rate Generator (BRG)”**).
2. Enable the asynchronous serial port by clearing bit SYNC and setting bit SPEN.

PIC16F917/916/914/913

FIGURE 11-1: USART TRANSMIT BLOCK DIAGRAM

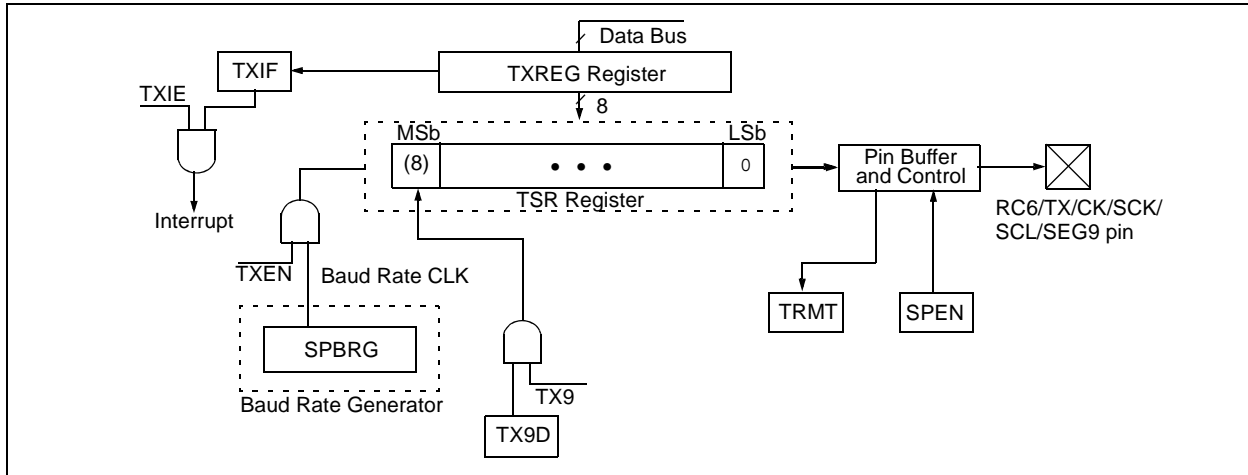

FIGURE 11-2: ASYNCHRONOUS MASTER TRANSMISSION

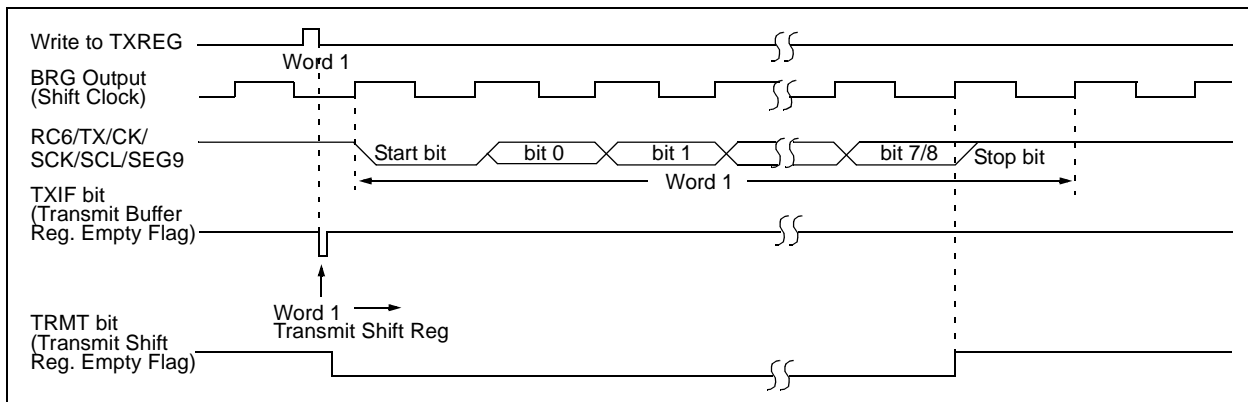

FIGURE 11-3: ASYNCHRONOUS MASTER TRANSMISSION (BACK-TO-BACK)

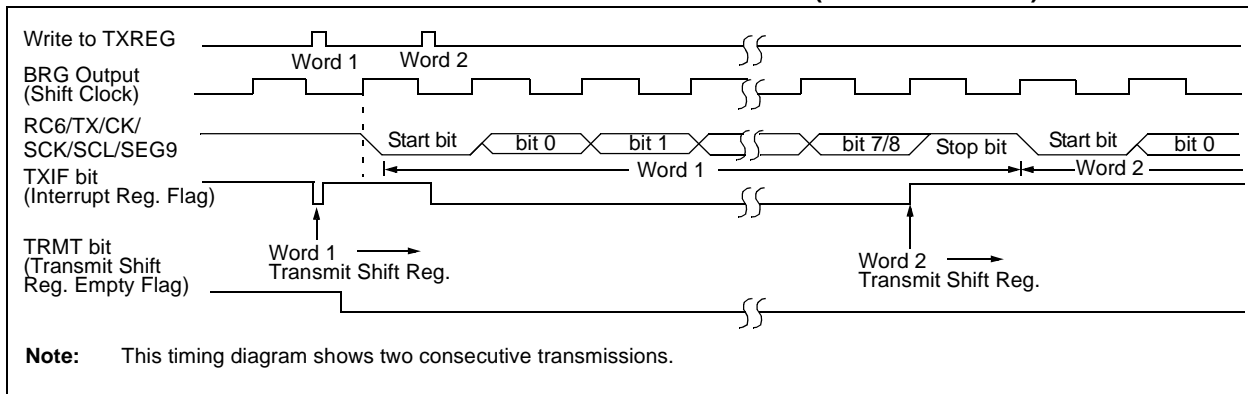

TABLE 11-5: REGISTERS ASSOCIATED WITH ASYNCHRONOUS TRANSMISSION

Address	Name	Bit 7	Bit 6	Bit 5	Bit 4	Bit 3	Bit 2	Bit 1	Bit 0	Value on: POR, BOR	Value on all other Resets	
0Bh, 8Bh, 10Bh,18Bh	INTCON	GIE	PEIE	TOIE	INTE	RBIE	TOIF	INTF	RBIF	0000 000x	0000 000x	
0Ch	PIR1	EEIF	ADIF	RCIF	TXIF	SSPIF	CCP1IF	TMR2IF	TMR1IF	0000 0000	0000 0000	
18h	RCSTA	SPEN	RX9	SREN	CREN	ADDEN	FERR	OERR	RX9D	0000 000x	0000 000x	
19h	TXREG	USART Transmit Data Register									0000 0000	0000 0000
8Ch	PIE1	EEIE	ADIE	RCIE	TXIE	SSPIE	CCP1IE	TMR2IE	TMR1IE	0000 0000	0000 0000	
98h	TXSTA	CSRC	TX9	TXEN	SYNC	—	BRGH	TRMT	TX9D	0000 -010	0000 -010	
99h	SPBRG	Baud Rate Generator Register									0000 0000	0000 0000

Legend: x = unknown, - = unimplemented locations read as '0'. Shaded cells are not used for asynchronous transmission.

PIC16F917/916/914/913

11.2.2 USART ASYNCHRONOUS RECEIVER

The receiver block diagram is shown in Figure 11-4. The data is received on the RC7/RX/DT/SDI/SDA/SEG8 pin and drives the data recovery block. The data recovery block is actually a high-speed shifter, operating at x16 times the baud rate; whereas the main receive serial shifter operates at the bit rate or at FOSC.

Once Asynchronous mode is selected, reception is enabled by setting bit CREN (RCSTA<4>).

The heart of the receiver is the Receive (Serial) Shift Register (RSR). After sampling the Stop bit, the received data in the RSR is transferred to the RCREG register (if it is empty). If the transfer is complete, flag bit, RCIF (PIR1<5>), is set. The actual interrupt can be enabled/disabled by setting/clearing enable bit, RCIE (PIE1<5>). Flag bit RCIF is a read-only bit which is cleared by the hardware. It is cleared when the RCREG register has been read and is empty. The RCREG is a double-buffered register (i.e., it is a two-deep FIFO). It is possible for two bytes of data to be received and transferred to the RCREG FIFO and a third byte to begin shifting to the RSR register. On the detection of the Stop bit of the third byte, if the RCREG register is still full, the Overrun Error bit, OERR (RCSTA<1>), will be set. The word in the RSR will be lost. The RCREG register can be read twice to retrieve the two bytes in the FIFO. Overrun bit OERR has to be cleared in software. This is done by resetting the receive logic (CREN is cleared and then set). If bit OERR is set, transfers from the RSR register to the RCREG register are inhibited and no further data will be received. It is, therefore, essential to clear error bit OERR if it is set. Framing error bit, FERR (RCSTA<2>), is set if a Stop bit is detected as clear. Bit FERR and the 9th receive bit are buffered the same way as the receive data. Reading the RCREG will load bits RX9D and FERR with new values, therefore, it is essential for the user to read the RCSTA register before reading the RCREG register in order to avoid losing data.

FIGURE 11-4: USART RECEIVE BLOCK DIAGRAM

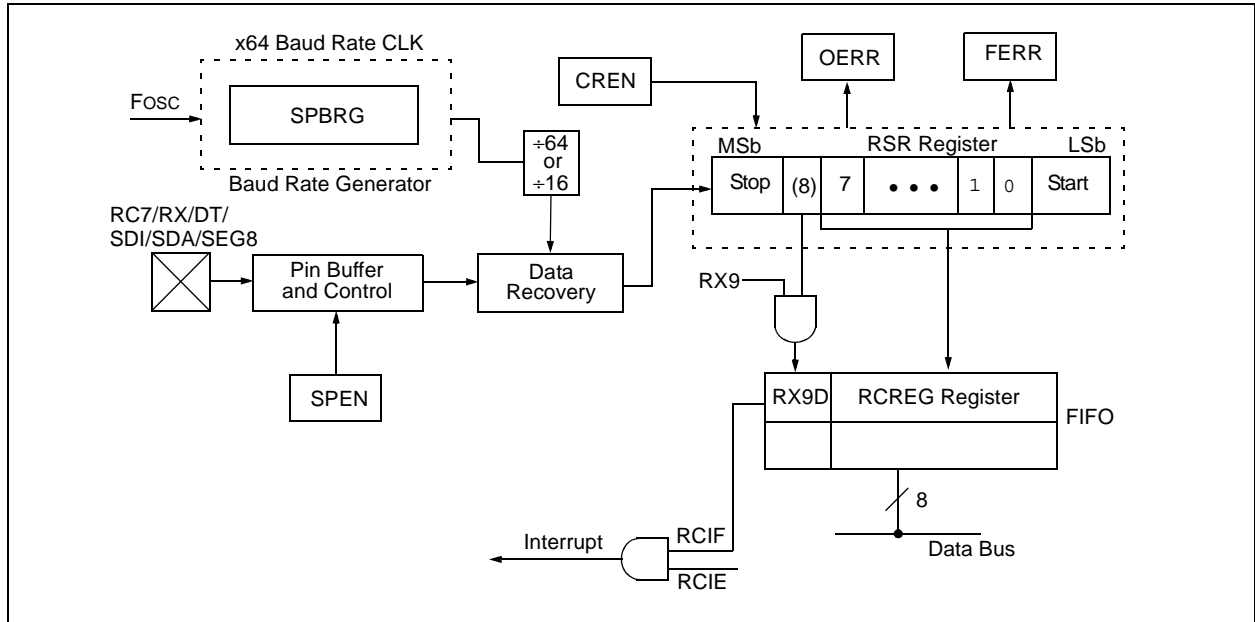

FIGURE 11-5: ASYNCHRONOUS RECEPTION

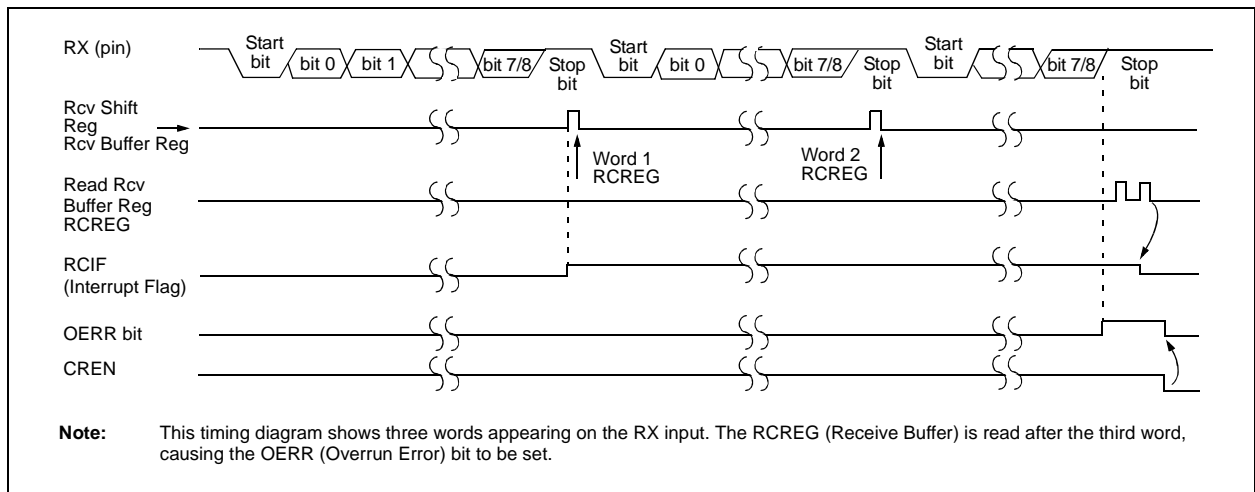

TABLE 11-6: REGISTERS ASSOCIATED WITH ASYNCHRONOUS RECEPTION

Address	Name	Bit 7	Bit 6	Bit 5	Bit 4	Bit 3	Bit 2	Bit 1	Bit 0	Value on: POR, BOR	Value on all other Resets
0Bh, 8Bh, 10Bh, 18Bh	INTCON	GIE	PEIE	TOIE	INTE	RBIE	T0IF	INTF	RBIF	0000 000x	0000 000x
0Ch	PIR1	EEIF	ADIF	RCIF	TXIF	SSPIF	CCP1IF	TMR2IF	TMR1IF	0000 0000	0000 0000
18h	RCSTA	SPEN	RX9	SREN	CREN	ADDEN	FERR	OERR	RX9D	0000 000x	0000 000x
1Ah	RCREG	USART Receive Data Register								0000 0000	0000 0000
8Ch	PIE1	EEIE	ADIE	RCIE	TXIE	SSPIE	CCP1IE	TMR2IE	TMR1IE	0000 0000	0000 0000
98h	TXSTA	CSRC	TX9	TXEN	SYNC	—	BRGH	TRMT	TX9D	0000 -010	0000 -010
99h	SPBRG	Baud Rate Generator Register								0000 0000	0000 0000

Legend: x = unknown, - = unimplemented locations read as '0'. Shaded cells are not used for asynchronous reception.

PIC16F917/916/914/913

11.2.3 SETTING UP 9-BIT MODE WITH ADDRESS DETECT

When setting up an Asynchronous Reception with address detect enabled:

- Initialize the SPBRG register for the appropriate baud rate. If a high-speed baud rate is desired, set bit BRGH.
- Enable the asynchronous serial port by clearing bit SYNC and setting bit SPEN.
- If interrupts are desired, then set enable bit RCIE.
- Set bit RX9 to enable 9-bit reception.
- Set ADDEN to enable address detect.
- Enable the reception by setting enable bit CREN.
- Flag bit RCIF will be set when reception is complete, and an interrupt will be generated if enable bit RCIE was set.
- Read the RCSTA register to get the ninth bit and determine if any error occurred during reception.
- Read the 8-bit received data by reading the RCREG register to determine if the device is being addressed.
- If any error occurred, clear the error by clearing enable bit CREN.
- If the device has been addressed, clear the ADDEN bit to allow data bytes and address bytes to be read into the receive buffer and interrupt the CPU.

FIGURE 11-6: USART RECEIVE BLOCK DIAGRAM

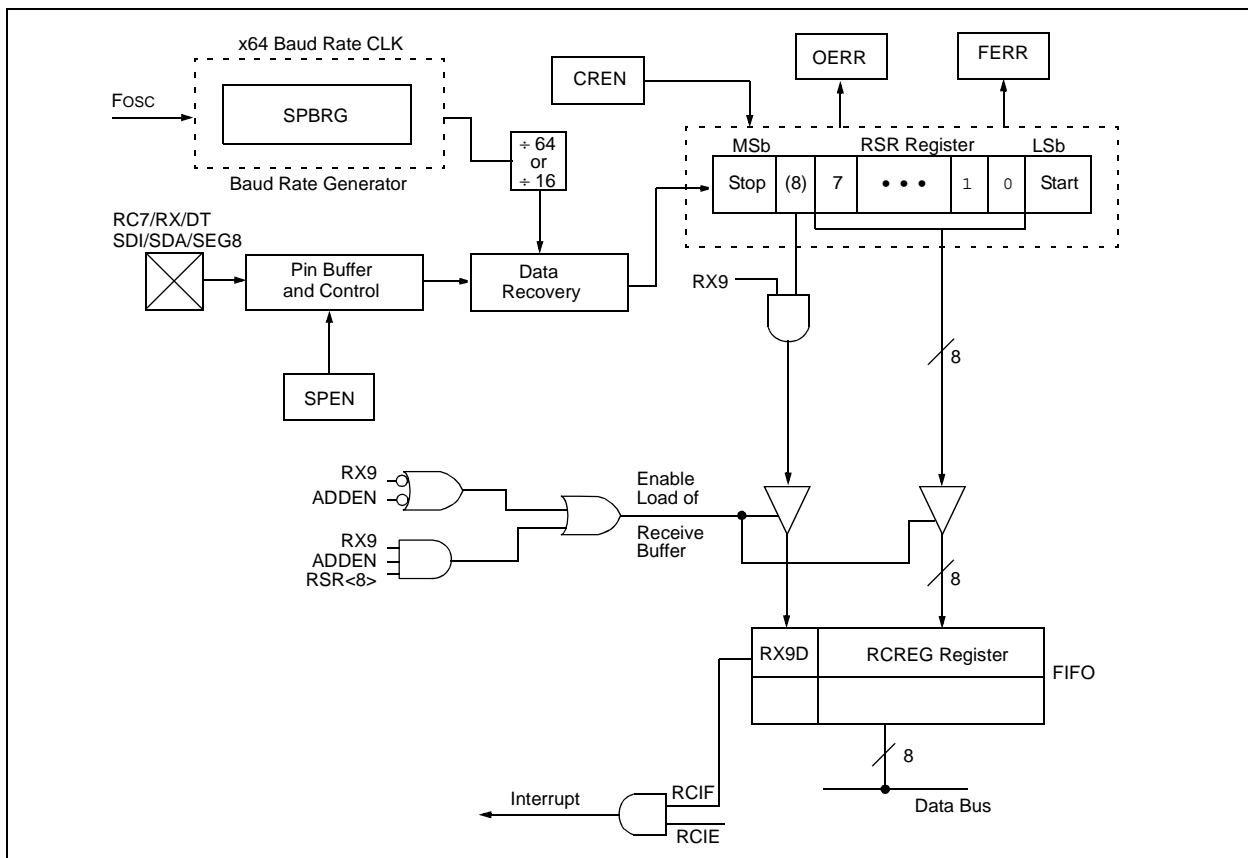

11.3 USART Synchronous Master Mode

In Synchronous Master mode, the data is transmitted in a half-duplex manner (i.e., transmission and reception do not occur at the same time). When transmitting data, the reception is inhibited and vice versa. Synchronous mode is entered by setting bit, SYNC (TXSTA<4>). In addition, enable bit, SPEN (RCSTA<7>), is set in order to configure the RC6/TX/CK/SCK/SCL/SEG9 and RC7/RX/DT/SDI/SDA/SEG8 I/O pins to CK (clock) and DT (data) lines, respectively. The Master mode indicates that the processor transmits the master clock on the CK line. The Master mode is entered by setting bit, CSRC (TXSTA<7>).

11.3.1 USART SYNCHRONOUS MASTER TRANSMISSION

The USART transmitter block diagram is shown in Figure 11-6. The heart of the transmitter is the Transmit (Serial) Shift Register (TSR). The shift register obtains its data from the Read/Write Transmit Buffer register, TXREG. The TXREG register is loaded with data in software. The TSR register is not loaded until the last bit has been transmitted from the previous load. As soon as the last bit is transmitted, the TSR is loaded with new data from the TXREG (if available). Once the TXREG register transfers the data to the TSR register (occurs in one TCYCLE), the TXREG is empty and interrupt bit, TXIF (PIR1<4>), is set. The interrupt can be enabled/disabled by setting/clearing enable bit TXIE (PIE1<4>). Flag bit TXIF will be set regardless of the state of enable bit TXIE and cannot be cleared in software. It will reset only when new data is loaded into the TXREG register. While flag bit TXIF indicates the status of the TXREG register, another bit, TRMT (TXSTA<1>), shows the status of the TSR register. TRMT is a read-only bit which is set when the TSR is empty. No interrupt logic is tied to this bit so the user has to poll this bit in order to determine if the TSR register is empty. The TSR is not mapped in data memory so it is not available to the user.

Transmission is enabled by setting enable bit, TXEN (TXSTA<5>). The actual transmission will not occur until the TXREG register has been loaded with data. The first data bit will be shifted out on the next available rising edge of the clock on the CK line. Data out is stable around the falling edge of the synchronous clock (Figure 11-9). The transmission can also be started by first loading the TXREG register and then setting bit TXEN (Figure 11-10). This is advantageous when slow baud rates are selected, since the BRG is kept in Reset when bits TXEN, CREN and SREN are clear. Setting enable bit TXEN will start the BRG, creating a shift clock immediately. Normally, when transmission is first started, the TSR register is empty, so a transfer to the TXREG register will result in an immediate transfer to TSR, resulting in an empty TXREG. Back-to-back transfers are possible.

Clearing enable bit TXEN during a transmission will cause the transmission to be aborted and will reset the transmitter. The DT and CK pins will revert to high-impedance. If either bit CREN or bit SREN is set during a transmission, the transmission is aborted and the DT pin reverts to a high-impedance state (for a reception). The CK pin will remain an output if bit CSRC is set (internal clock). The transmitter logic, however, is not reset, although it is disconnected from the pins. In order to reset the transmitter, the user has to clear bit TXEN. If bit SREN is set (to interrupt an on-going transmission and receive a single word), then after the single word is received, bit SREN will be cleared and the serial port will revert back to transmitting, since bit TXEN is still set. The DT line will immediately switch from High-Impedance Receive mode to transmit and start driving. To avoid this, bit TXEN should be cleared.

In order to select 9-bit transmission, the TX9 (TXSTA<6>) bit should be set and the ninth bit should be written to bit TX9D (TXSTA<0>). The ninth bit must be written before writing the 8-bit data to the TXREG register. This is because a data write to the TXREG can result in an immediate transfer of the data to the TSR register (if the TSR is empty). If the TSR was empty and the TXREG was written before writing the “new” TX9D, the “present” value of bit TX9D is loaded.

Steps to follow when setting up a Synchronous Master Transmission:

1. Initialize the SPBRG register for the appropriate baud rate (**Section 11.1 “USART Baud Rate Generator (BRG)”**).
2. Enable the synchronous master serial port by setting bits SYNC, SPEN and CSRC.
3. If interrupts are desired, set enable bit TXIE.
4. If 9-bit transmission is desired, set bit TX9.
5. Enable the transmission by setting bit TXEN.
6. If 9-bit transmission is selected, the ninth bit should be loaded in bit TX9D.
7. Start transmission by loading data to the TXREG register.
8. If using interrupts, ensure that GIE and PEIE (bits 7 and 6) of the INTCON register are set.

TABLE 11-8: REGISTERS ASSOCIATED WITH SYNCHRONOUS MASTER TRANSMISSION

Address	Name	Bit 7	Bit 6	Bit 5	Bit 4	Bit 3	Bit 2	Bit 1	Bit 0	Value on: POR, BOR	Value on all other Resets
0Bh, 8Bh, 10Bh, 18Bh	INTCON	GIE	PEIE	T0IE	INTE	RBIE	T0IF	INTF	RBIF	0000 000x	0000 000x
0Ch	PIR1	EEIF	ADIF	RCIF	TXIF	SSPIF	CCP1IF	TMR2IF	TMR1IF	0000 0000	0000 0000
18h	RCSTA	SPEN	RX9	SREN	CREN	ADDEN	FERR	OERR	RX9D	0000 000x	0000 000x
19h	TXREG	USART Transmit Data Register								0000 0000	0000 0000
8Ch	PIE1	EEIE	ADIE	RCIE	TXIE	SSPIE	CCP1IE	TMR2IE	TMR1IE	0000 0000	0000 0000
98h	TXSTA	CSRC	TX9	TXEN	SYNC	—	BRGH	TRMT	TX9D	0000 -010	0000 -010
99h	SPBRG	Baud Rate Generator Register								0000 0000	0000 0000

Legend: x = unknown, - = unimplemented, read as '0'. Shaded cells are not used for synchronous master transmission.

FIGURE 11-9: SYNCHRONOUS TRANSMISSION

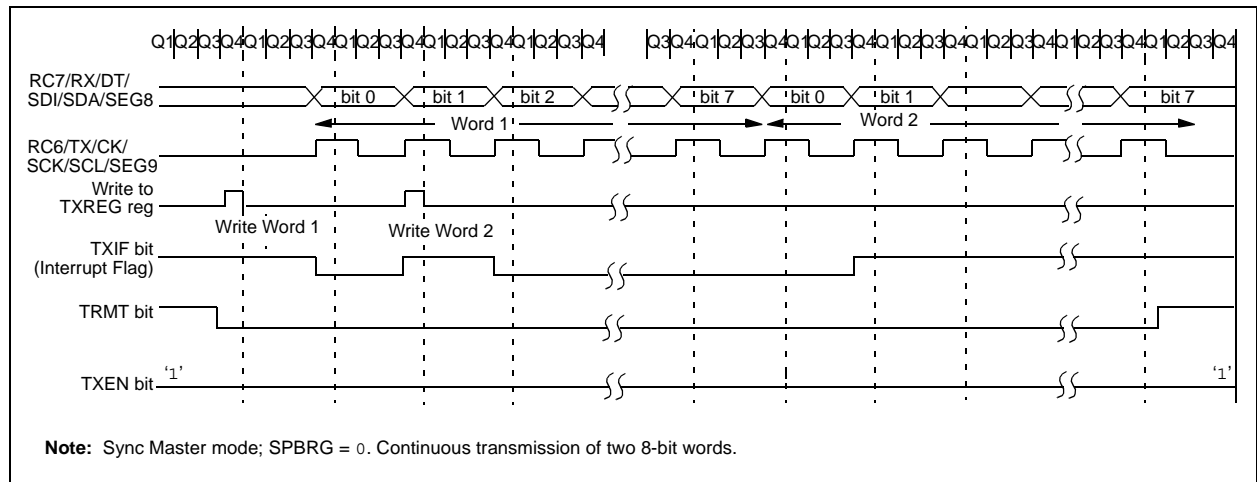
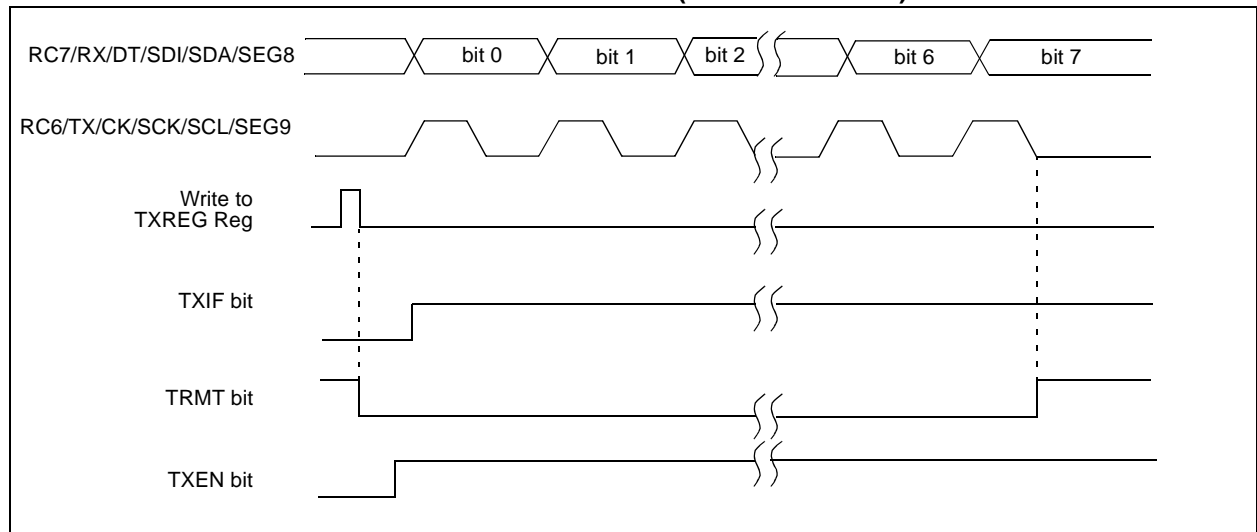

FIGURE 11-10: SYNCHRONOUS TRANSMISSION (THROUGH TXEN)



PIC16F917/916/914/913

11.3.2 USART SYNCHRONOUS MASTER RECEPTION

Once Synchronous mode is selected, reception is enabled by setting either enable bit, SREN (RCSTA<5>), or enable bit, CREN (RCSTA<4>). Data is sampled on the RC7/RX/DT/SDI/SDA/SEG8 pin on the falling edge of the clock. If enable bit SREN is set, then only a single word is received. If enable bit CREN is set, the reception is continuous until CREN is cleared. If both bits are set, CREN takes precedence. After clocking the last bit, the received data in the Receive Shift Register (RSR) is transferred to the RCREG register (if it is empty). When the transfer is complete, interrupt flag bit, RCIF (PIR1<5>), is set. The actual interrupt can be enabled/disabled by setting/clearing enable bit, RCIE (PIE1<5>). Flag bit RCIF is a read-only bit which is reset by the hardware. In this case, it is reset when the RCREG register has been read and is empty. The RCREG is a double-buffered register (i.e., it is a two-deep FIFO). It is possible for two bytes of data to be received and transferred to the RCREG FIFO and a third byte to begin shifting into the RSR register. On the clocking of the last bit of the third byte, if the RCREG register is still full, then Overrun Error bit, OERR (RCSTA<1>), is set. The word in the RSR will be lost. The RCREG register can be read twice to retrieve the two bytes in the FIFO. Bit OERR has to be cleared in software (by clearing bit CREN). If bit OERR is set, transfers from the RSR to the RCREG are inhibited so it is essential to clear bit OERR if it is set. The ninth receive bit is buffered the same way as the receive data. Reading the RCREG register will load bit RX9D with a new value, therefore, it is essential for the user to read the RCSTA register before reading RCREG in order not to lose the old RX9D information.

When setting up a Synchronous Master Reception:

1. Initialize the SPBRG register for the appropriate baud rate (**Section 11.1 “USART Baud Rate Generator (BRG)”**).
2. Enable the synchronous master serial port by setting bits SYNC, SPEN and CSRC.
3. Ensure bits CREN and SREN are clear.
4. If interrupts are desired, then set enable bit RCIE.
5. If 9-bit reception is desired, then set bit RX9.
6. If a single reception is required, set bit SREN. For continuous reception, set bit CREN.
7. Interrupt flag bit RCIF will be set when reception is complete and an interrupt will be generated if enable bit RCIE was set.
8. Read the RCSTA register to get the ninth bit (if enabled) and determine if any error occurred during reception.
9. Read the 8-bit received data by reading the RCREG register.
10. If any error occurred, clear the error by clearing bit CREN.
11. If using interrupts, ensure that GIE and PEIE (bits 7 and 6) of the INTCON register are set.

TABLE 11-9: REGISTERS ASSOCIATED WITH SYNCHRONOUS MASTER RECEPTION

Address	Name	Bit 7	Bit 6	Bit 5	Bit 4	Bit 3	Bit 2	Bit 1	Bit 0	Value on: POR, BOR	Value on all other Resets
0Bh, 8Bh, 10Bh, 18Bh	INTCON	GIE	PEIE	T0IE	INTE	RBIE	T0IF	INTF	RBIF	0000 000x	0000 000x
0Ch	PIR1	EEIF	ADIF	RCIF	TXIF	SSPIF	CCP1IF	TMR2IF	TMR1IF	0000 0000	0000 0000
18h	RCSTA	SPEN	RX9	SREN	CREN	ADDEN	FERR	OERR	RX9D	0000 000x	0000 000x
1Ah	RCREG	USART Receive Data Register								0000 0000	0000 0000
8Ch	PIE1	EEIE	ADIE	RCIE	TXIE	SSPIE	CCP1IE	TMR2IE	TMR1IE	0000 0000	0000 0000
98h	TXSTA	CSRC	TX9	TXEN	SYNC	—	BRGH	TRMT	TX9D	0000 -010	0000 -010
99h	SPBRG	Baud Rate Generator Register								0000 0000	0000 0000

Legend: x = unknown, - = unimplemented, read as '0'. Shaded cells are not used for synchronous master reception.

FIGURE 11-11: SYNCHRONOUS RECEPTION (MASTER MODE, SREN)

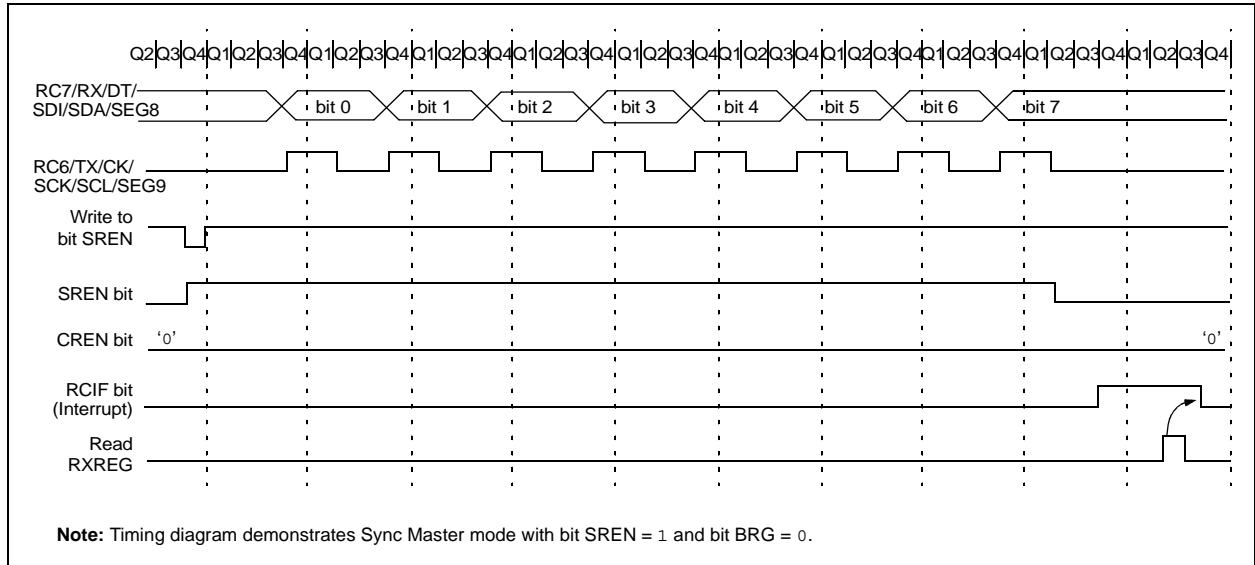

11.4 USART Synchronous Slave Mode

Synchronous Slave mode differs from the Master mode in the fact that the shift clock is supplied externally at the RC6/TX/CK/SCK/SCL/SEG9 pin (instead of being supplied internally in Master mode). This allows the device to transfer or receive data while in Sleep mode. Slave mode is entered by clearing bit, CSRC (TXSTA<7>).

11.4.1 USART SYNCHRONOUS SLAVE TRANSMIT

The operation of the Synchronous Master and Slave modes is identical, except in the case of the Sleep mode.

If two words are written to the TXREG and then the SLEEP instruction is executed, the following will occur:

- The first word will immediately transfer to the TSR register and transmit.
- The second word will remain in TXREG register.
- Flag bit TXIF will not be set.
- When the first word has been shifted out of TSR, the TXREG register will transfer the second word to the TSR and flag bit TXIF will now be set.
- If enable bit TXIE is set, the interrupt will wake the chip from Sleep and if the global interrupt is enabled, the program will branch to the interrupt vector (0004h).

When setting up a Synchronous Slave Transmission, follow these steps:

- Enable the synchronous slave serial port by setting bits SYNC and SPEN and clearing bit CSRC.
- Clear bits CREN and SREN.
- If interrupts are desired, then set enable bit TXIE.
- If 9-bit transmission is desired, then set bit TX9.
- Enable the transmission by setting enable bit TXEN.
- If 9-bit transmission is selected, the ninth bit should be loaded in bit TX9D.
- Start transmission by loading data to the TXREG register.
- If using interrupts, ensure that GIE and PEIE (bits 7 and 6) of the INTCON register are set.

12.0 ANALOG-TO-DIGITAL CONVERTER (A/D) MODULE

The Analog-to-Digital converter (A/D) allows conversion of an analog input signal to a 10-bit binary representation of that signal. The PIC16F917/916/914/913 has up to eight analog inputs, multiplexed into one sample and hold circuit. The output of the sample and hold is connected to the input of the converter. The converter generates a binary result via successive approximation and stores the result in a 10-bit register. The voltage reference used in the conversion is software selectable to either VDD or a voltage applied by the VREF pin. Figure 12-1 shows the block diagram of the A/D on the PIC16F917/916/914/913.

FIGURE 12-1: A/D BLOCK DIAGRAM

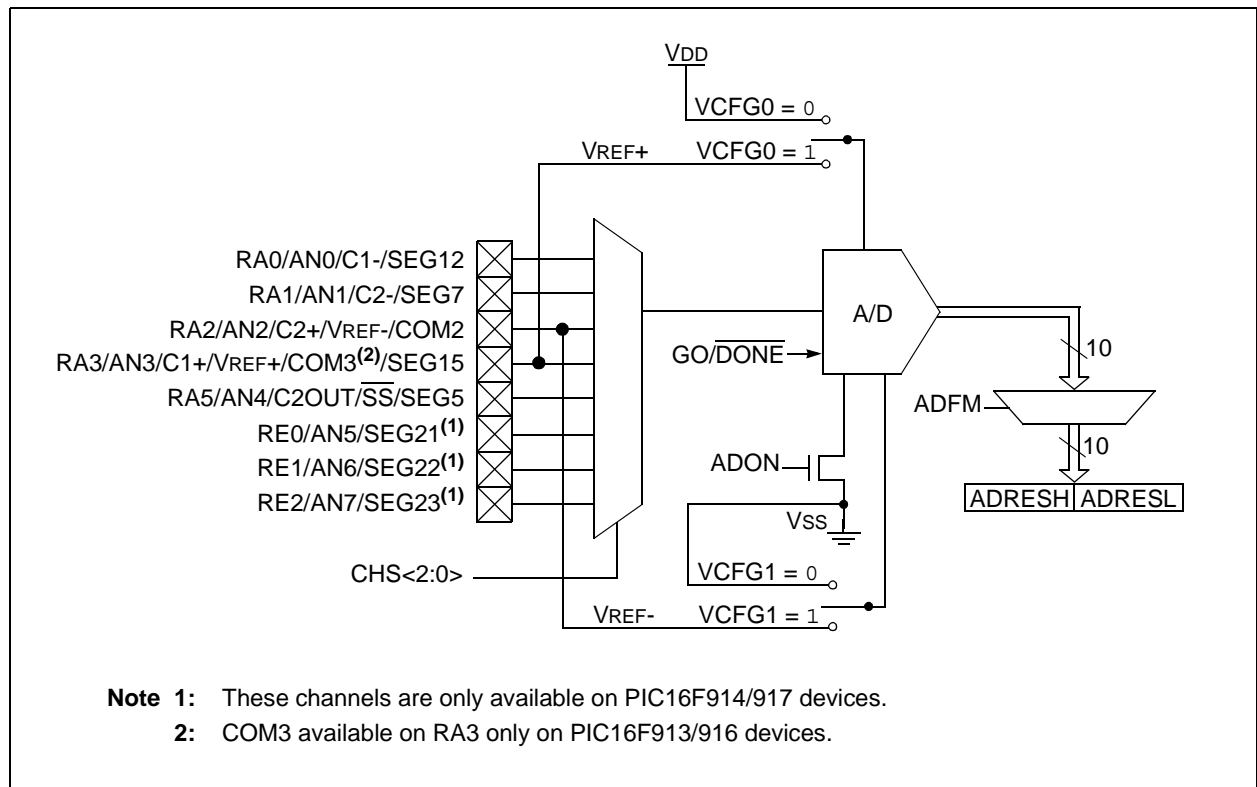

PIC16F917/916/914/913

12.1 A/D Configuration and Operation

There are three registers available to control the functionality of the A/D module:

1. ANSEL (Register 12-1)
2. ADCON0 (Register 12-2)
3. ADCON1 (Register 12-3)

12.1.1 ANALOG PORT PINS

The ANS<7:0> bits (ANSEL<7:0>) and the TRIS bits control the operation of the A/D port pins. Set the corresponding TRIS bits to set the pin output driver to its high-impedance state. Likewise, set the corresponding ANSEL bit to disable the digital input buffer.

Note: Analog voltages on any pin that is defined as a digital input may cause the input buffer to conduct excess current.

12.1.2 CHANNEL SELECTION

There are up to eight analog channels on the PIC16F917/916/914/913, AN<7:0>. The CHS<2:0> bits (ADCON0<4:2>) control which channel is connected to the sample and hold circuit.

12.1.3 VOLTAGE REFERENCE

There are two options for each reference to the A/D converter, VREF+ and VREF-. VREF+ can be connected to either VDD or an externally applied voltage. Alternatively, VREF- can be connected to either VSS or an externally applied voltage. VCFG<1:0> bits are used to select the reference source.

12.1.4 CONVERSION CLOCK

The A/D conversion cycle requires 11 TAD. The source of the conversion clock is software selectable via the ADCS bits (ADCON1<6:4>). There are seven possible clock options:

- Fosc/2
- Fosc/4
- Fosc/8
- Fosc/16
- Fosc/32
- Fosc/64
- FRC (dedicated internal oscillator)

For correct conversion, the A/D conversion clock (1/TAD) must be selected to ensure a minimum TAD of 1.6 μ s. Table 12-1 shows a few TAD calculations for selected frequencies.

TABLE 12-1: TAD vs. DEVICE OPERATING FREQUENCIES

A/D Clock Source (TAD)		Device Frequency			
Operation	ADCS<2:0>	20 MHz	5 MHz	4 MHz	1.25 MHz
2 TOSC	000	100 ns ⁽²⁾	400 ns ⁽²⁾	500 ns ⁽²⁾	1.6 μ s
4 TOSC	100	200 ns ⁽²⁾	800 ns ⁽²⁾	1.0 μ s ⁽²⁾	3.2 μ s
8 TOSC	001	400 ns ⁽²⁾	1.6 μ s	2.0 μ s	6.4 μ s
16 TOSC	101	800 ns ⁽²⁾	3.2 μ s	4.0 μ s	12.8 μ s ⁽³⁾
32 TOSC	010	1.6 μ s	6.4 μ s	8.0 μ s ⁽³⁾	25.6 μ s ⁽³⁾
64 TOSC	110	3.2 μ s	12.8 μ s ⁽³⁾	16.0 μ s ⁽³⁾	51.2 μ s ⁽³⁾
A/D RC	x11	2-6 μ s ^(1,4)	2-6 μ s ^(1,4)	2-6 μ s ^(1,4)	2-6 μ s ^(1,4)

Legend: Shaded cells are outside of recommended range.

Note 1: The A/D RC source has a typical TAD time of 4 μ s for VDD > 3.0V.

2: These values violate the minimum required TAD time.

3: For faster conversion times, the selection of another clock source is recommended.

4: When the device frequency is greater than 1 MHz, the A/D RC clock source is only recommended if the conversion will be performed during Sleep.

12.1.5 STARTING A CONVERSION

The A/D conversion is initiated by setting the GO/DONE bit (ADCON0<1>). When the conversion is complete, the A/D module:

- Clears the GO/DONE bit
- Sets the ADIF flag (PIR1<6>)
- Generates an interrupt (if enabled)

If the conversion must be aborted, the GO/DONE bit can be cleared in software. The ADRESH:ADRESL registers will not be updated with the partially complete A/D conversion sample. Instead, the ADRESH:ADRESL registers will retain the value of the previous conversion. After an aborted conversion, a 2 TAD delay is required before another acquisition can be initiated. Following the delay, an input acquisition is automatically started on the selected channel.

Note: The GO/DONE bit should not be set in the same instruction that turns on the A/D.

FIGURE 12-2: A/D CONVERSION TAD CYCLES

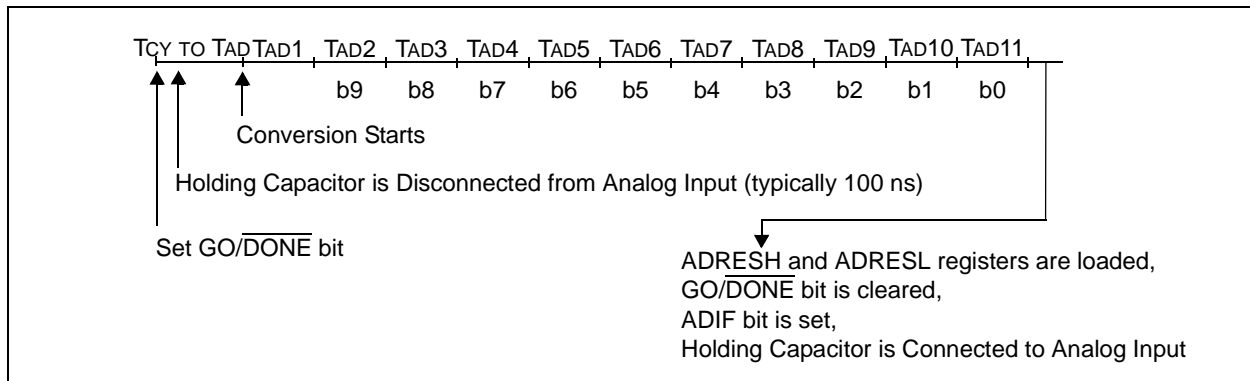

12.1.6 CONVERSION OUTPUT

The A/D conversion can be supplied in two formats: left or right shifted. The ADFM bit (ADCON0<7>) controls the output format. Figure 12-3 shows the output formats.

FIGURE 12-3: 10-BIT A/D RESULT FORMAT

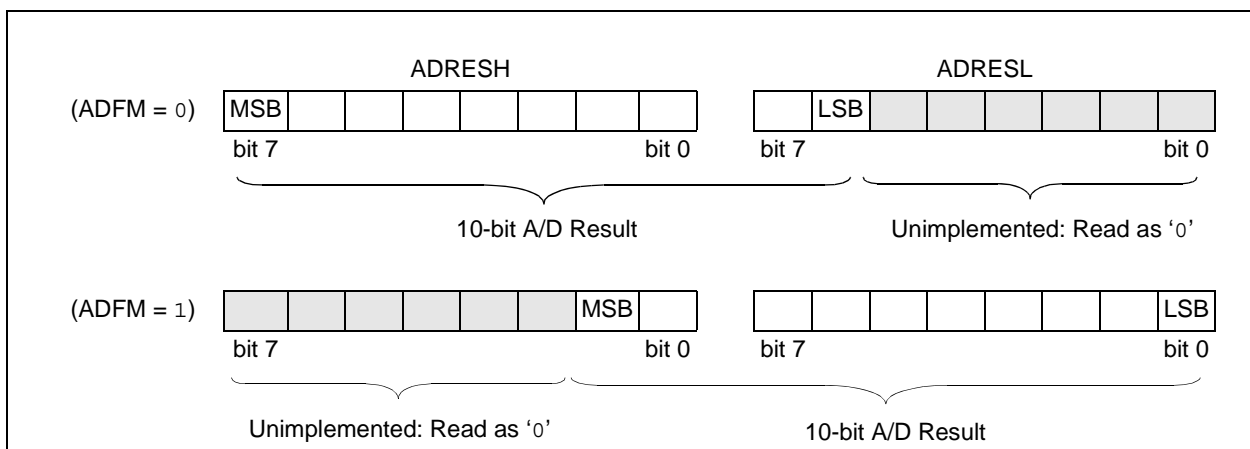

PIC16F917/916/914/913

REGISTER 12-1: ANSEL – ANALOG SELECT REGISTER (ADDRESS: 91h)

R/W-1	R/W-1	R/W-1	R/W-1	R/W-1	R/W-1	R/W-1	R/W-1	
ANS7 ⁽²⁾	ANS6 ⁽²⁾	ANS5 ⁽²⁾	ANS4	ANS3	ANS2	ANS1	ANS0	
bit 7								bit 0

bit 7-0: **ANS<7:0>**: Analog Select bits⁽²⁾

Select between analog or digital function on pins AN<7:0>, respectively.

1 = Analog input. Pin is assigned as analog input.⁽¹⁾

0 = Digital I/O. Pin is assigned to port or special function.

Note 1: Setting a pin to an analog input automatically disables the digital input circuitry, weak pull-ups, and interrupt-on-change if available. The corresponding TRIS bit must be set to Input mode in order to allow external control of the voltage on the pin.

2: ANS<7:5> on PIC16F914/917 only; forced '0' on PIC16F913/916.

Legend:

R = Readable bit

W = Writable bit

U = Unimplemented bit, read as '0'

- n = Value at POR

'1' = Bit is set

'0' = Bit is cleared

x = Bit is unknown

REGISTER 12-2: ADCON0 – A/D CONTROL REGISTER (ADDRESS: 1Fh)

R/W-0	R/W-0	R/W-0	R/W-0	R/W-0	R/W-0	R/W-0	R/W-0	
ADFM	VCFG1	VCFG0	CHS2	CHS1	CHS0	GO/DONE	ADON	
bit 7								bit 0

bit 7 **ADFM**: A/D Result Formed Select bit

1 = Right justified

0 = Left justified

bit 6 **VCFG1**: Voltage Reference bit

1 = VREF- pin

0 = VSS

bit 5 **VCFG0**: Voltage Reference bit

1 = VREF+ pin

0 = VDD

bit 4-2 **CHS<2:0>**: Analog Channel Select bits

000 = Channel 00 (AN0)

001 = Channel 01 (AN1)

010 = Channel 02 (AN2)

011 = Channel 03 (AN3)

100 = Channel 04 (AN4)

101 = Channel 05 (AN5)

110 = Channel 06 (AN6)

111 = Channel 07 (AN7)

bit 1 **GO/DONE**: A/D Conversion Status bit

1 = A/D conversion cycle in progress. Setting this bit starts an A/D conversion cycle.

This bit is automatically cleared by hardware when the A/D conversion has completed.

0 = A/D conversion completed/not in progress

bit 0 **ADON**: A/D Conversion Status bit

1 = A/D converter module is operating

0 = A/D converter is shut off and consumes no operating current

Legend:

R = Readable bit

W = Writable bit

U = Unimplemented bit, read as '0'

- n = Value at POR

'1' = Bit is set

'0' = Bit is cleared

x = Bit is unknown

PIC16F917/916/914/913

REGISTER 12-3: ADCON1 – A/D CONTROL REGISTER 1 (ADDRESS: 9Fh)

U-0	R/W-0	R/W-0	R/W-0	U-0	U-0	U-0	U-0
—	ADCS2	ADCS1	ADCS0	—	—	—	—
bit 7							bit 0

bit 7 **Unimplemented:** Read as '0'

bit 6-4 **ADCS<2:0>:** A/D Conversion Clock Select bits

000 = FOSC/2

001 = FOSC/8

010 = FOSC/32

x11 = FRC (clock derived from a dedicated internal oscillator = 500 kHz max)

100 = FOSC/4

101 = FOSC/16

110 = FOSC/64

bit 3-0 **Unimplemented:** Read as '0'

Legend:

R = Readable bit

W = Writable bit

U = Unimplemented bit, read as '0'

- n = Value at POR

'1' = Bit is set

'0' = Bit is cleared

x = Bit is unknown

PIC16F917/916/914/913

12.1.7 CONFIGURING THE A/D

After the A/D module has been configured as desired, the selected channel must be acquired before the conversion is started. The analog input channels must have their corresponding TRIS bits selected as inputs.

To determine sample time, see **Section 19.0 “Electrical Specifications”**. After this sample time has elapsed, the A/D conversion can be started.

These steps should be followed for an A/D conversion:

1. Configure the A/D module:
 - Configure analog/digital I/O (ANSEL)
 - Configure voltage reference (ADCON0)
 - Select A/D input channel (ADCON0)
 - Select A/D conversion clock (ADCON1)
 - Turn on A/D module (ADCON0)
2. Configure A/D interrupt (if desired):
 - Clear ADIF bit (PIR1<6>)
 - Set ADIE bit (PIE1<6>)
 - Set PEIE and GIE bits (INTCON<7:6>)
3. Wait the required acquisition time.
4. Start conversion:
 - Set $\overline{GO/DONE}$ bit (ADCON0<1>)
5. Wait for A/D conversion to complete, by either:
 - Polling for the $\overline{GO/DONE}$ bit to be cleared (with interrupts disabled); OR
 - Waiting for the A/D interrupt
6. Read A/D Result register pair (ADRESH:ADRESL); clear bit ADIF if required.
7. For next conversion, go to step 1 or step 2 as required. The A/D conversion time per bit is defined as TAD. A minimum wait of 2 TAD is required before the next acquisition starts.

EXAMPLE 12-1: A/D CONVERSION

```
;This code block configures the A/D
;for polling, Vdd reference, R/C clock
;and RA0 input.
;
;Conversion start and wait for complete
;polling code included.
;
BSF    STATUS,RP0    ;Bank 1
MOVLW B'01110000'   ;A/D RC clock
MOVWF  ADCON1
BSF    TRISA,0       ;Set RA0 to input
BSF    ANSEL,0       ;Set RA0 to analog
BCF    STATUS,RP0    ;Bank 0
MOVLW B'10000001'   ;Right, Vdd Vref, AN0
MOVWF  ADCON0
CALL   SampleTime   ;Wait min sample time
BSF    ADCON0,GO     ;Start conversion
BTFSC  ADCON0,GO     ;Is conversion done?
GOTO   $-1           ;No, test again
MOVF   ADRESH,W     ;Read upper 2 bits
MOVWF  RESULTHI
BSF    STATUS,RP0    ;Bank 1
MOVF   ADRESL,W     ;Read lower 8 bits
MOVWF  RESULTLO
```

12.2 A/D Acquisition Requirements

For the A/D converter to meet its specified accuracy, the charge holding capacitor (CHOLD) must be allowed to fully charge to the input channel voltage level. The analog input model is shown in Figure 12-4. The source impedance (RS) and the internal sampling switch (RSS) impedance directly affect the time required to charge the capacitor CHOLD. The sampling switch (RSS) impedance varies over the device voltage (VDD), see Figure 12-4. **The maximum recommended impedance for analog sources is 10 kΩ.**

As the impedance is decreased, the acquisition time may be decreased. After the analog input channel is selected (changed), this acquisition must be done before the conversion can be started.

To calculate the minimum acquisition time, Equation 12-1 may be used. This equation assumes that 1/2 LSB error is used (1024 steps for the A/D). The 1/2 LSB error is the maximum error allowed for the A/D to meet its specified resolution.

To calculate the minimum acquisition time, TACQ, see the "PICmicro® Mid-Range MCU Family Reference Manual" (DS33023).

EQUATION 12-1: ACQUISITION TIME

$$\begin{aligned} T_{ACQ} &= \text{Amplifier Settling Time} + \text{Hold Capacitor Charging Time} + \text{Temperature Coefficient} \\ &= T_{AMP} + T_C + T_{COFF} \\ &= 2\mu\text{s} + T_C + [(Temperature - 25^\circ\text{C})(0.05\mu\text{s}/^\circ\text{C})] \end{aligned}$$

Where CHOLD is charged to within 1/2 lsb:

$$V_{APPLIED} \left(1 - \frac{1}{2047} \right) = V_{CHOLD} \quad ;[1] \text{ } V_{CHOLD} \text{ charged to within } 1/2 \text{ lsb}$$

$$V_{APPLIED} \left(1 - e^{-\frac{T_C}{RC}} \right) = V_{CHOLD} \quad ;[2] \text{ } V_{CHOLD} \text{ charge response to } V_{APPLIED}$$

$$V_{APPLIED} \left(1 - e^{-\frac{T_C}{RC}} \right) = V_{APPLIED} \left(1 - \frac{1}{2047} \right) \quad ;\text{combining [1] and [2]}$$

Solving for TC:

$$\begin{aligned} T_C &= -CHOLD(RIC + RSS + RS) \ln(1/2047) \\ &= -10\text{pF}(1\text{k}\Omega + 7\text{k}\Omega + 10\text{k}\Omega) \ln(0.0004885) \\ &= 1.37\mu\text{s} \end{aligned}$$

Therefore:

$$\begin{aligned} T_{ACQ} &= 2\mu\text{s} + 1.37\mu\text{s} + [(50^\circ\text{C} - 25^\circ\text{C})(0.05\mu\text{s}/^\circ\text{C})] \\ &= 4.67\mu\text{s} \end{aligned}$$

Note 1: The reference voltage (VREF) has no effect on the equation, since it cancels itself out.

2: The charge holding capacitor (CHOLD) is not discharged after each conversion.

3: The maximum recommended impedance for analog sources is 10 kΩ. This is required to meet the pin leakage specification.

PIC16F917/916/914/913

FIGURE 12-4: ANALOG INPUT MODEL

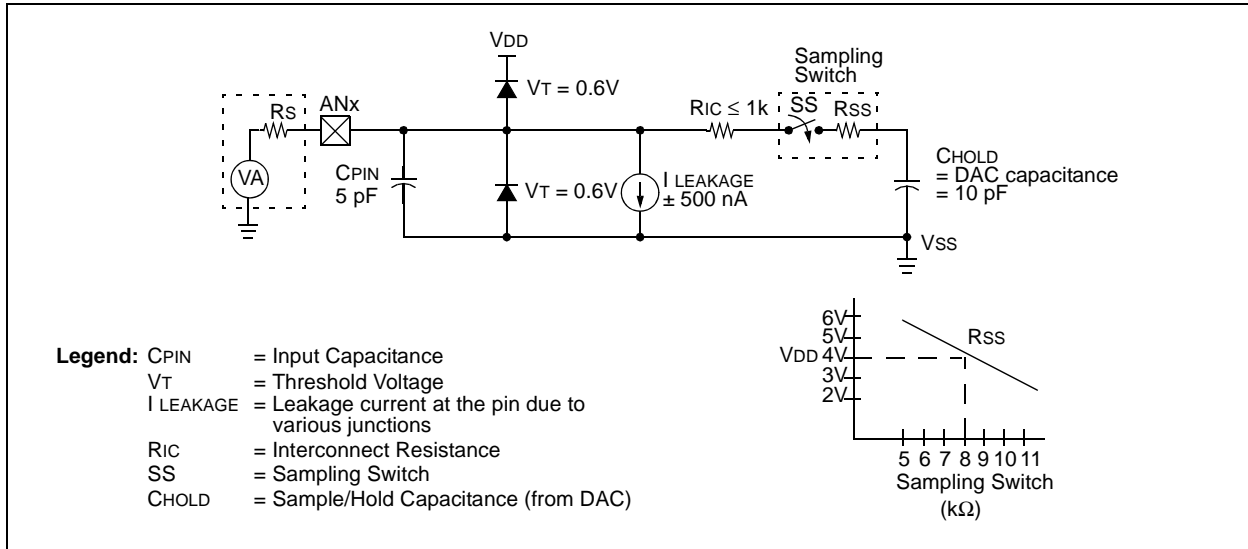

12.3 A/D Operation During Sleep

The A/D converter module can operate during Sleep. This requires the A/D clock source to be set to the internal oscillator. When the RC clock source is selected, the A/D waits one instruction before starting the conversion. This allows the SLEEP instruction to be executed, thus eliminating much of the switching noise from the conversion. When the conversion is complete, the GO/DONE bit is cleared and the result is loaded into the ADRESH:ADRESL registers. If the A/D

interrupt is enabled, the device awakens from Sleep. If the GIE bit (INTCON<7>) is set, the program counter is set to the interrupt vector (0004h). If GIE is clear, the next instruction is executed. If the A/D interrupt is not enabled, the A/D module is turned off, although the ADON bit remains set.

When the A/D clock source is something other than RC, a SLEEP instruction causes the present conversion to be aborted, and the A/D module is turned off. The ADON bit remains set.

FIGURE 12-5: A/D TRANSFER FUNCTION

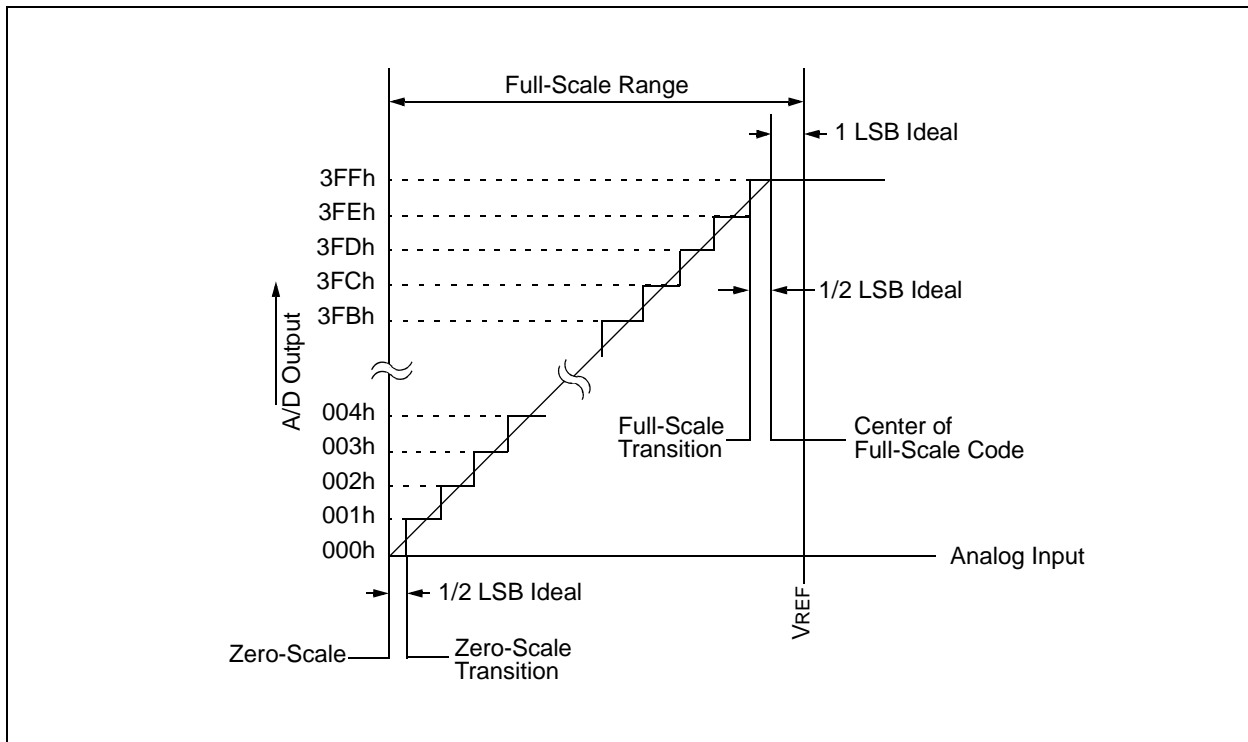

12.4 Effects of Reset

A device Reset forces all registers to their Reset state. Thus, the A/D module is turned off and any pending conversion is aborted. The ADRESH:ADRESL registers are unchanged.

TABLE 12-2: SUMMARY OF A/D REGISTERS

Addr	Name	Bit 7	Bit 6	Bit 5	Bit 4	Bit 3	Bit 2	Bit 1	Bit 0	Value on: POR, BOR	Value on all other Resets
05h	PORTA	RA7	RA6	RA5	RA4	RA3	RA2	RA1	RA0	xxxx xxxx	uuuu uuuu
09h	PORTE	—	—	—	—	RE3	RE2	RE1	RE0	---- xxxx	---- uuuu
0Bh/ 8Bh	INTCON	GIE	PEIE	T0IE	INTE	RBIE	T0IF	INTF	RBIF	0000 000x	0000 000x
0Ch	PIR1	EEIF	ADIF	RCIF	TXIF	SSPIF	CCP1IF	TMR2IF	TMR1IF	0000 0000	0000 0000
1Eh	ADRESH	Most Significant 8 bits of the left justified A/D result or 2 bits of the right justified result								xxxx xxxx	uuuu uuuu
1Fh	ADCON0	ADFM	VCFG1	VCFG0	CHS2	CHS1	CHS0	GO/DONE	ADON	0000 0000	0000 0000
85h	TRISA	TRISA7	TRISA6	TRISA5	TRISA4	TRISA3	TRISA2	TRISA1	TRISA0	1111 1111	1111 1111
89h	TRISE	—	—	—	—	TRISE3	TRISE2	TRISE1	TRISE0	---- 1111	---- 1111
8Ch	PIE1	EEIE	ADIE	RCIE	TXIE	SSPIE	CCP1IE	TMR2IE	TMR1IE	0000 0000	0000 0000
91h	ANSEL	ANS7	ANS6	ANS5	ANS4	ANS3	ANS2	ANS1	ANS0	1111 1111	1111 1111
9Eh	ADRESL	Least Significant 2 bits of the left justified A/D result or 8 bits of the right justified result								xxxx xxxx	uuuu uuuu
9Fh	ADCON1	—	ADCS2	ADCS1	ADCS0	—	—	—	—	-000 ----	-000 ----

Legend: x = unknown, u = unchanged, - = unimplemented read as '0'. Shaded cells are not used for A/D module.

PIC16F917/916/914/913

NOTES:

13.0 DATA EEPROM AND FLASH PROGRAM MEMORY CONTROL

Data EEPROM memory is readable and writable and the Flash program memory is readable during normal operation (full VDD range). These memories are not directly mapped in the register file space. Instead, they are indirectly addressed through the Special Function Registers. There are six SFRs used to access these memories:

- EECON1
- EECON2
- EEDATL
- EEDATH
- EEADRL
- EEADRH

When interfacing the data memory block, EEDATL holds the 8-bit data for read/write, and EEADRL holds the address of the EE data location being accessed. This device has 256 bytes of data EEPROM with an address range from 0h to 0FFh.

When interfacing the program memory block, the EEDATL and EEDATH registers form a 2-byte word that holds the 14-bit data for read, and the EEADRL and EEADRH registers form a 2-byte word that holds the 13-bit address of the EEPROM location being accessed. This device has 4k and 8k words of program EEPROM with an address range from 0h-0FFFh and 0h-1FFFh. The program memory allows one word reads.

The EEPROM data memory allows byte read and write. A byte write automatically erases the location and writes the new data (erase before write).

The write time is controlled by an on-chip timer. The write/erase voltages are generated by an on-chip charge pump rated to operate over the voltage range of the device for byte or word operations.

When the device is code-protected, the CPU may continue to read and write the data EEPROM memory and read the program memory. When code-protected, the device programmer can no longer access data or program memory.

Additional information on the data EEPROM is available in the "PICmicro® Mid-Range MCU Family Reference Manual" (DS33023).

13.1 EEADRL and EEADRH Registers

The EEADRL and EEADRH registers can address up to a maximum of 256 bytes of data EEPROM or up to a maximum of 8k words of program EEPROM.

When selecting a program address value, the MSB of the address is written to the EEADRH register and the LSB is written to the EEADRL register. When selecting a data address value, only the LSB of the address is written to the EEADRL register.

13.1.1 EECON1 AND EECON2 REGISTERS

EECON1 is the control register for EE memory accesses.

Control bit EEPGD determines if the access will be a program or data memory access. When clear, as it is when reset, any subsequent operations will operate on the data memory. When set, any subsequent operations will operate on the program memory. Program memory can only be read.

Control bits RD and WR initiate read and write, respectively. These bits cannot be cleared, only set, in software. They are cleared in hardware at completion of the read or write operation. The inability to clear the WR bit in software prevents the accidental, premature termination of a write operation.

The WREN bit, when set, will allow a write operation to data EEPROM. On power-up, the WREN bit is clear. The WRERR bit is set when a write operation is interrupted by a MCLR or a WDT Time-out Reset during normal operation. In these situations, following Reset, the user can check the WRERR bit and rewrite the location. The data and address will be unchanged in the EEDATL and EEADRL registers.

Interrupt flag bit EEIF (PIR1<7>), is set when write is complete. It must be cleared in the software.

EECON2 is not a physical register. Reading EECON2 will read all '0's. The EECON2 register is used exclusively in the data EEPROM write sequence.

PIC16F917/916/914/913

REGISTER 13-1: EEDATL – EEPROM DATA LOW BYTE REGISTER (ADDRESS: 10Ch)

R/W-0	R/W-0	R/W-0	R/W-0	R/W-0	R/W-0	R/W-0	R/W-0
EEDATL7	EEDATL6	EEDATL5	EEDATL4	EEDATL3	EEDATL2	EEDATL1	EEDATL0
bit 7							bit 0

bit 7-0 **EEDATL<7:0>**: Byte value to Write to or Read from data EEPROM bits or to Read from program memory

Legend:			
R = Readable bit	W = Writable bit	U = Unimplemented bit, read as '0'	
- n = Value at POR	'1' = Bit is set	'0' = Bit is cleared	x = Bit is unknown

REGISTER 13-2: EEADRL – EEPROM ADDRESS LOW BYTE REGISTER (ADDRESS: 10Dh)

R/W-0	R/W-0	R/W-0	R/W-0	R/W-0	R/W-0	R/W-0	R/W-0
EEADRL7	EEADRL6	EEADRL5	EEADRL4	EEADRL3	EEADRL2	EEADRL1	EEADRL0
bit 7							bit 0

bit 7-0 **EEADRL<7:0>**: Specifies one of 256 locations for EEPROM Read/Write operation bits or low byte for program memory reads

Legend:			
R = Readable bit	W = Writable bit	U = Unimplemented bit, read as '0'	
- n = Value at POR	'1' = Bit is set	'0' = Bit is cleared	x = Bit is unknown

REGISTER 13-3: EEDATH – EEPROM DATA HIGH BYTE REGISTER (ADDRESS: 10Eh)

U-0	U-0	R/W-0	R/W-0	R/W-0	R/W-0	R/W-0	R/W-0
—	—	EEDATH5	EEDATH4	EEDATH3	EEDATH2	EEDATH1	EEDATH0
bit 7							bit 0

bit 5-0 **EEDATH<5:0>**: Byte value to Write to or Read from data EEPROM bits or to Read from program memory

Legend:			
R = Readable bit	W = Writable bit	U = Unimplemented bit, read as '0'	
- n = Value at POR	'1' = Bit is set	'0' = Bit is cleared	x = Bit is unknown

REGISTER 13-4: EEADRH – EEPROM ADDRESS HIGH BYTE REGISTER (ADDRESS: 10Fh)

U-0	U-0	U-0	R/W-0	R/W-0	R/W-0	R/W-0	R/W-0
—	—	—	EEADRH4	EEADRH3	EEADRH2	EEADRH1	EEADRH0
bit 7							bit 0

bit 4-0 **EEADRH<4:0>**: Specifies one of 256 locations for EEPROM Read/Write operation bits or high bits for program memory reads

Legend:			
R = Readable bit	W = Writable bit	U = Unimplemented bit, read as '0'	
- n = Value at POR	'1' = Bit is set	'0' = Bit is cleared	x = Bit is unknown

PIC16F917/916/914/913

REGISTER 13-5: EECON1 – EEPROM CONTROL REGISTER 1 (ADDRESS: 18Ch)

R/W-0	U-0	U-0	U-0	R/W-x	R/W-0	R/S-0	R/S-0
EEPGD	—	—	—	WRERR	WREN	WR	RD

bit 7

bit 0

- bit 7 **EEPGD:** Program/Data EEPROM Select bit
 1 = Accesses program memory
 0 = Accesses data memory
- bit 6-4 **Unimplemented:** Read as '0'
- bit 3 **WRERR:** EEPROM Error Flag bit
 1 = A write operation is prematurely terminated (any $\overline{\text{MCLR}}$ Reset, any WDT Reset during normal operation or BOR Reset)
 0 = The write operation completed
- bit 2 **WREN:** EEPROM Write Enable bit
 1 = Allows write cycles
 0 = Inhibits write to the data EEPROM
- bit 1 **WR:** Write Control bit
EEPGD = 1:
 This bit is ignored
EEPGD = 0:
 1 = Initiates a write cycle (The bit is cleared by hardware once write is complete. The WR bit can only be set, not cleared, in software.)
 0 = Write cycle to the data EEPROM is complete
- bit 0 **RD:** Read Control bit
 1 = Initiates a memory read (RD is cleared in hardware. The RD bit can only be set, not cleared, in software.)
 0 = Does not initiate an memory read

Legend:

S = Bit can only be set

R = Readable bit

- n = Value at POR

W = Writable bit

'1' = Bit is set

U = Unimplemented bit, read as '0'

'0' = Bit is cleared

x = Bit is unknown

PIC16F917/916/914/913

13.1.2 READING THE DATA EEPROM MEMORY

To read a data memory location, the user must write the address to the EEADRL register, clear the EEPGD control bit (EECON1<7>), and then set control bit RD (EECON1<0>). The data is available in the very next cycle, in the EEDATL register; therefore, it can be read in the next instruction. EEDATL will hold this value until another read or until it is written to by the user (during a write operation).

EXAMPLE 13-1: DATA EEPROM READ

```
BSF    STATUS,RP1    ;
BCF    STATUS,RP0    ; Bank 2
MOVF   DATA_EE_ADDR,W ; Data Memory
MOVWF  EEADR         ; Address to read
BSF    STATUS,RP0    ; Bank 3
BCF    EECON1,EEPGD ; Point to Data
                           ; memory
BSF    EECON1,RD     ; EE Read
BCF    STATUS,RP0    ; Bank 2
MOVF   EEDATA,W     ; W = EEDATA
```

13.1.3 WRITING TO THE DATA EEPROM MEMORY

To write an EEPROM data location, the user must first write the address to the EEADRL register and the data to the EEDATL register. Then the user must follow a specific sequence to initiate the write for each byte.

The write will not initiate if the sequence described below is not followed exactly (write 55h to EECON2, write AAh to EECON2, then set WR bit) for each byte. Interrupts should be disabled during this code segment.

Additionally, the WREN bit in EECON1 must be set to enable write. This mechanism prevents accidental writes to data EEPROM due to errant (unexpected) code execution (i.e., lost programs). The user should keep the WREN bit clear at all times, except when updating EEPROM. The WREN bit is not cleared by hardware.

After a write sequence has been initiated, clearing the WREN bit will not affect this write cycle. The WR bit will be inhibited from being set unless the WREN bit is set.

At the completion of the write cycle, the WR bit is cleared in hardware and the EE Write Complete Interrupt Flag bit (EEIF) is set. The user can either enable this interrupt or poll this bit. EEIF must be cleared by software.

The steps to write to EEPROM data memory are:

1. If step 10 is not implemented, check the WR bit to see if a write is in progress.
2. Write the address to EEADR. Make sure that the address is not larger than the memory size of the device.
3. Write the 8-bit data value to be programmed in the EEDATA register.
4. Clear the EEPGD bit to point to EEPROM data memory.
5. Set the WREN bit to enable program operations.
6. Disable interrupts (if enabled).
7. Execute the special five instruction sequence:
 - Write 55h to EECON2 in two steps (first to W, then to EECON2)
 - Write AAh to EECON2 in two steps (first to W, then to EECON2)
 - Set the WR bit
8. Enable interrupts (if using interrupts).
9. Clear the WREN bit to disable program operations.
10. At the completion of the write cycle, the WR bit is cleared and the EEIF interrupt flag bit is set. (EEIF must be cleared by firmware.) If step 1 is not implemented, then firmware should check for EEIF to be set, or WR to clear, to indicate the end of the program cycle.

EXAMPLE 13-2: DATA EEPROM WRITE

```
BSF    STATUS,RP1    ;
BSF    STATUS,RP0
BTFSC  EECON1,WR     ;Wait for write
GOTO   $-1           ;to complete
BCF    STATUS,RP0    ;Bank 2
MOVF   DATA_EE_ADDR,W;Data Memory
MOVWF  EEADR         ;Address to write
MOVF   DATA_EE_DATA,W;Data Memory Value
MOVWF  EEDATA        ;to write
BSF    STATUS,RP0    ;Bank 3
BCF    EECON1,EEPGD ;Point to DATA
                           ;memory
BSF    EECON1,WREN   ;Enable writes

BSF    INTCON,GIE    ;Disable INTs.
MOVLW  55h           ;
MOVWF  EECON2        ;Write 55h
MOVLW  AAh           ;
MOVWF  EECON2        ;Write AAh
BSF    EECON1,WR     ;Set WR bit to
                           ;begin write
BSF    INTCON,GIE    ;Enable INTs.
BCF    EECON1,WREN   ;Disable writes
```

Required Sequence

13.1.4 READING THE FLASH PROGRAM MEMORY

To read a program memory location, the user must write two bytes of the address to the EEADRL and EEADRH registers, set the EEPGD control bit (EECON1<7>), and then set control bit RD (EECON1<0>). Once the read control bit is set, the program memory Flash controller will use the second instruction cycle to read the data. This causes the second instruction immediately following the "BSF EECON1, RD" instruction to be ignored. The data is available in the very next cycle, in the EEDATL and EEDATH registers; therefore, it can be read as two bytes in the following instructions. EEDATL and EEDATH registers will hold this value until another read or until it is written to by the user (during a write operation).

Note 1: The two instructions following a program memory read are required to be NOP's. This prevents the user from executing a two-cycle instruction on the next instruction after the RD bit is set.

2: If the WR bit is set when EEPGD = 1, it will be immediately reset to '0' and no operation will take place.

EXAMPLE 13-3: FLASH PROGRAM READ

```

BSF    STATUS, RP1    ;
BCF    STATUS, RP0    ; Bank 2
MOVLW  MS_PROG_EE_ADDR;
MOVWF  EEADRH        ; MS Byte of Program Address to read
MOVLW  LS_PROG_EE_ADDR;
MOVWF  EEADR         ; LS Byte of Program Address to read
BSF    STATUS, RP0    ; Bank 3
BSF    EECON1, EEPGD ; Point to PROGRAM memory
BSF    EECON1, RD    ; EE Read
;
Required Sequence ;
NOP
NOP                ; Any instructions here are ignored as program
                  ; memory is read in second cycle after BSF EECON1,RD
;
BCF    STATUS, RP0    ; Bank 2
MOVWF  EEDATA, W     ; W = LS Byte of Program EEDATA
MOVWF  DATAL         ;
MOVWF  EEDATH, W     ; W = MS Byte of Program EEDATA
MOVWF  DATAH        ;
    
```

PIC16F917/916/914/913

FIGURE 13-1: FLASH PROGRAM MEMORY READ CYCLE EXECUTION

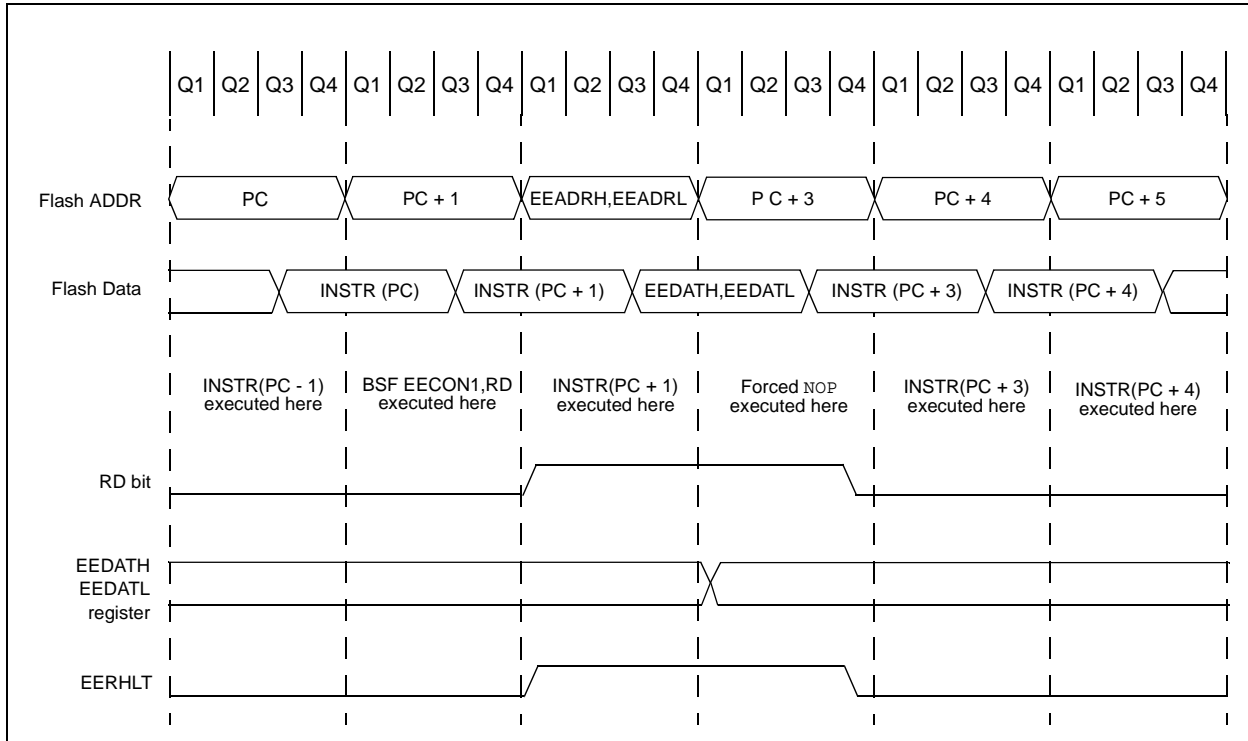

TABLE 13-1: REGISTERS/BITS ASSOCIATED WITH DATA EEPROM

Addr	Name	Bit 7	Bit 6	Bit 5	Bit 4	Bit 3	Bit 2	Bit 1	Bit 0	Value on POR, BOR	Value on all other Resets
0Bh/8Bh/10Bh	INTCON	GIE	PEIE	TOIE	INTE	RBIE	T0IF	INTF	RBIF	0000 000x	0000 000x
0Ch	PIR1	EEIF	ADIF	RCIF	TXIF	SSPIF	CCP1IF	TMR2IF	TMR1IF	0000 0000	0000 0000
8Ch	PIE1	EEIE	ADIE	RCIE	TXIE	SSPIE	CCP1IE	TMR2IE	TMR1IE	0000 0000	0000 0000
10Ch	EEDATL	EEDATL7	EEDATL6	EEDATL5	EEDATL4	EEDATL3	EEDATL2	EEDATL1	EEDATL0	0000 0000	0000 0000
10Dh	EEADRL	EEADRL7	EEADRL6	EEADRL5	EEADRL4	EEADRL3	EEADRL2	EEADRL1	EEADRL0	0000 0000	0000 0000
10Eh	EEDATH	—	—	EEDATH5	EEDATH4	EEDATH3	EEDATH2	EEDATH1	EEDATH0	--00 0000	--00 0000
10Fh	EEADRH	—	—	—	EEADRH4	EEADRH3	EEADRH2	EEADRH1	EEADRH0	---0 0000	---0 0000
18Ch	EECON1	EEPGD	—	—	—	WRERR	WREN	WR	RD	0--- x000	---- q000
18Dh	EECON2	EEPROM Control Register 2 (not a physical register)								---- ----	---- ----

Legend: x = unknown, u = unchanged, - = unimplemented read as '0', q = value depends upon condition. Shaded cells are not used by data EEPROM module.

14.0 SSP MODULE OVERVIEW

The Synchronous Serial Port (SSP) module is a serial interface used to communicate with other peripheral or microcontroller devices. These peripheral devices may be serial EEPROMs, shift registers, display drivers, A/D converters, etc. The SSP module can operate in one of two modes:

- Serial Peripheral Interface (SPI™)
- Inter-Integrated Circuit (I²C™)

An overview of I²C operations and additional information on the SSP module can be found in the “PICmicro® Mid-Range MCU Family Reference Manual” (DS33023).

Refer to Application Note AN578, “Use of the SSP Module in the Multi-Master Environment” (DS00578).

14.1 SPI Mode

This section contains register definitions and operational characteristics of the SPI module. Additional information on the SPI module can be found in the “PICmicro® Mid-Range MCU Family Reference Manual” (DS33023).

The SPI mode allows 8 bits of data to be synchronously transmitted and received simultaneously. To accomplish communication, typically three pins are used:

- Serial Data Out (SDO) – RC4/ $\overline{T1G}$ /SDO/SEG11
- Serial Data In (SDI) – RC7/RX/DT/SDI/SDA/SEG8
- Serial Clock (SCK) – RC6/TX/CK/SCK/SCL/SEG9

Additionally, a fourth pin may be used when in a Slave mode of operation:

- Slave Select (\overline{SS}) – RA5/AN4/C2OUT/ \overline{SS} /SEG5

When initializing the SPI, several options need to be specified. This is done by programming the appropriate control bits in the SSPCON register (SSPCON<5:0>) and SSPSTAT<7:6>. These control bits allow the following to be specified:

- Master mode (SCK is the clock output)
- Slave mode (SCK is the clock input)
- Clock Polarity (Idle state of SCK)
- Clock edge (output data on rising/falling edge of SCK)
- Clock Rate (Master mode only)
- Slave Select mode (Slave mode only)

PIC16F917/916/914/913

REGISTER 14-1: SSPSTAT – SYNC SERIAL PORT STATUS REGISTER (ADDRESS 94h)

R/W-0	R/W-0	R-0	R-0	R-0	R-0	R-0	R-0
SMP	CKE	D \bar{A}	P	S	R \bar{W}	UA	BF
bit 7						bit 0	

- bit 7 **SMP**: SPI™ Data Input Sample Phase bit
SPI Master mode:
 1 = Input data sampled at end of data output time
 0 = Input data sampled at middle of data output time (Microwire)
SPI Slave mode:
 SMP must be cleared when SPI is used in Slave mode
I²C™ mode:
 This bit must be maintained clear
- bit 6 **CKE**: SPI Clock Edge Select bit
SPI mode, CKP = 0:
 1 = Data transmitted on falling edge of SCK
 0 = Data transmitted on rising edge of SCK (Microwire alternate)
SPI mode, CKP = 1:
 1 = Data transmitted on rising edge of SCK
 0 = Data transmitted on falling edge of SCK (Microwire default)
I²C mode:
 This bit must be maintained clear
- bit 5 **D \bar{A}** : Data/Address bit (I²C mode only)
 1 = Indicates that the last byte received or transmitted was data
 0 = Indicates that the last byte received or transmitted was address
- bit 4 **P**: Stop bit (I²C mode only)
 This bit is cleared when the SSP module is disabled, or when the Start bit is detected last. SSPEN is cleared.
 1 = Indicates that a Stop bit has been detected last (this bit is '0' on Reset)
 0 = Stop bit was not detected last
- bit 3 **S**: Start bit (I²C mode only)
 This bit is cleared when the SSP module is disabled, or when the Stop bit is detected last. SSPEN is cleared.
 1 = Indicates that a Start bit has been detected last (this bit is '0' on Reset)
 0 = Start bit was not detected last
- bit 2 **R \bar{W}** : Read/Write bit Information (I²C mode only)
 This bit holds the R \bar{W} bit information following the last address match. This bit is only valid from the address match to the next Start bit, Stop bit or ACK bit.
 1 = Read
 0 = Write
- bit 1 **UA**: Update Address bit (10-bit I²C mode only)
 1 = Indicates that the user needs to update the address in the SSPADD register
 0 = Address does not need to be updated
- bit 0 **BF**: Buffer Full Status bit
Receive (SPI and I²C modes):
 1 = Receive complete, SSPBUF is full
 0 = Receive not complete, SSPBUF is empty
Transmit (I²C mode only):
 1 = Transmit in progress, SSPBUF is full
 0 = Transmit complete, SSPBUF is empty

Legend:

R = Readable bit	W = Writable bit	U = Unimplemented bit, read as '0'
- n = Value at POR	'1' = Bit is set	'0' = Bit is cleared x = Bit is unknown

PIC16F917/916/914/913

REGISTER 14-2: SSPCON – SYNC SERIAL PORT CONTROL REGISTER (ADDRESS 14h)

R/W-0	R/W-0	R/W-0	R/W-0	R/W-0	R/W-0	R/W-0	R/W-0
WCOL	SSPOV	SSPEN	CKP	SSPM3	SSPM2	SSPM1	SSPM0
bit 7							bit 0

bit 7 **WCOL:** Write Collision Detect bit

1 = The SSPBUF register is written while it is still transmitting the previous word (must be cleared in software)

0 = No collision

bit 6 **SSPOV:** Receive Overflow Indicator bit

In SPI™ mode:

1 = A new byte is received while the SSPBUF register is still holding the previous data. In case of overflow, the data in SSPSR is lost. Overflow can only occur in Slave mode. The user must read the SSPBUF, even if only transmitting data, to avoid setting overflow. In Master mode, the overflow bit is not set since each new reception (and transmission) is initiated by writing to the SSPBUF register.

0 = No overflow

In I²C™ mode:

1 = A byte is re

PIC16F917/916/914/913

14.2 Operation

When initializing the SPI, several options need to be specified. This is done by programming the appropriate control bits (SSPCON<5:0> and SSPSTAT<7:6>). These control bits allow the following to be specified:

- Master mode (SCK is the clock output)
- Slave mode (SCK is the clock input)
- Clock Polarity (Idle state of SCK)
- Data Input Sample Phase (middle or end of data output time)
- Clock Edge (output data on rising/falling edge of SCK)
- Clock Rate (Master mode only)
- Slave Select mode (Slave mode only)

The SSP consists of a transmit/receive shift register (SSPSR) and a buffer register (SSPBUF). The SSPSR shifts the data in and out of the device, MSb first. The SSPBUF holds the data that was written to the SSPSR until the received data is ready. Once the eight bits of data have been received, that byte is moved to the SSPBUF register. Then, the Buffer Full detect bit, BF (SSPSTAT<0>), and the interrupt flag bit, SSPIF, are set. This double-buffering of the received data (SSPBUF) allows the next byte to start reception before reading the data that was just received. Any write to the SSPBUF register during transmission/reception of data will be ignored and the write collision detect bit, WCOL (SSPCON<7>), will be set. User software must clear the WCOL bit so that it can be determined if the following write(s) to the SSPBUF register completed successfully.

When the application software is expecting to receive valid data, the SSPBUF should be read before the next byte of data to transfer is written to the SSPBUF. Buffer Full bit, BF (SSPSTAT<0>), indicates when SSPBUF has been loaded with the received data (transmission is complete). When the SSPBUF is read, the BF bit is cleared. This data may be irrelevant if the SPI is only a transmitter. Generally, the SSP interrupt is used to determine when the transmission/reception has completed. The SSPBUF must be read and/or written. If the interrupt method is not going to be used, then software polling can be done to ensure that a write collision does not occur. Example 14-1 shows the loading of the SSPBUF (SSPSR) for data transmission.

The SSPSR is not directly readable or writable and can only be accessed by addressing the SSPBUF register. Additionally, the SSP Status register (SSPSTAT) indicates the various status conditions.

EXAMPLE 14-1: LOADING THE SSPBUF (SSPSR) REGISTER

LOOP	BTFSS	SSPSTAT, BF	;Has data been received(transmit complete)?
	BRA	LOOP	;No
	MOVF	SSPBUF, W	;WREG reg = contents of SSPBUF
	MOVWF	RXDATA	;Save in user RAM, if data is meaningful
	MOVF	TXDATA, W	;W reg = contents of TXDATA
	MOVWF	SSPBUF	;New data to xmit

PIC16F917/916/914/913

14.3 Enabling SPI I/O

To enable the serial port, SSP Enable bit, SSPEN (SSPCON<5>), must be set. To reset or reconfigure SPI mode, clear the SSPEN bit, re-initialize the SSPCON registers and then set the SSPEN bit. This configures the SDI, SDO, SCK and \overline{SS} pins as serial port pins. For the pins to behave as the serial port function, some must have their data direction bits (in the TRIS register) appropriately programmed. That is:

- SDI is automatically controlled by the SPI module
- SDO must have TRISC<4> bit cleared
- SCK (Master mode) must have TRISC<6> bit cleared
- SCK (Slave mode) must have TRISC<6> bit set
- \overline{SS} must have TRISA<5> bit set

Any serial port function that is not desired may be overridden by programming the corresponding data direction (TRIS) register to the opposite value.

14.4 Typical Connection

Figure 14-2 shows a typical connection between two microcontrollers. The master controller (Processor 1) initiates the data transfer by sending the SCK signal. Data is shifted out of both shift registers on their programmed clock edge and latched on the opposite edge of the clock. Both processors should be programmed to the same Clock Polarity (CKP), then both controllers would send and receive data at the same time. Whether the data is meaningful (or dummy data) depends on the application software. This leads to three scenarios for data transmission:

- Master sends data – Slave sends dummy data
- Master sends data – Slave sends data
- Master sends dummy data – Slave sends data

FIGURE 14-2: SPI™ MASTER/SLAVE CONNECTION

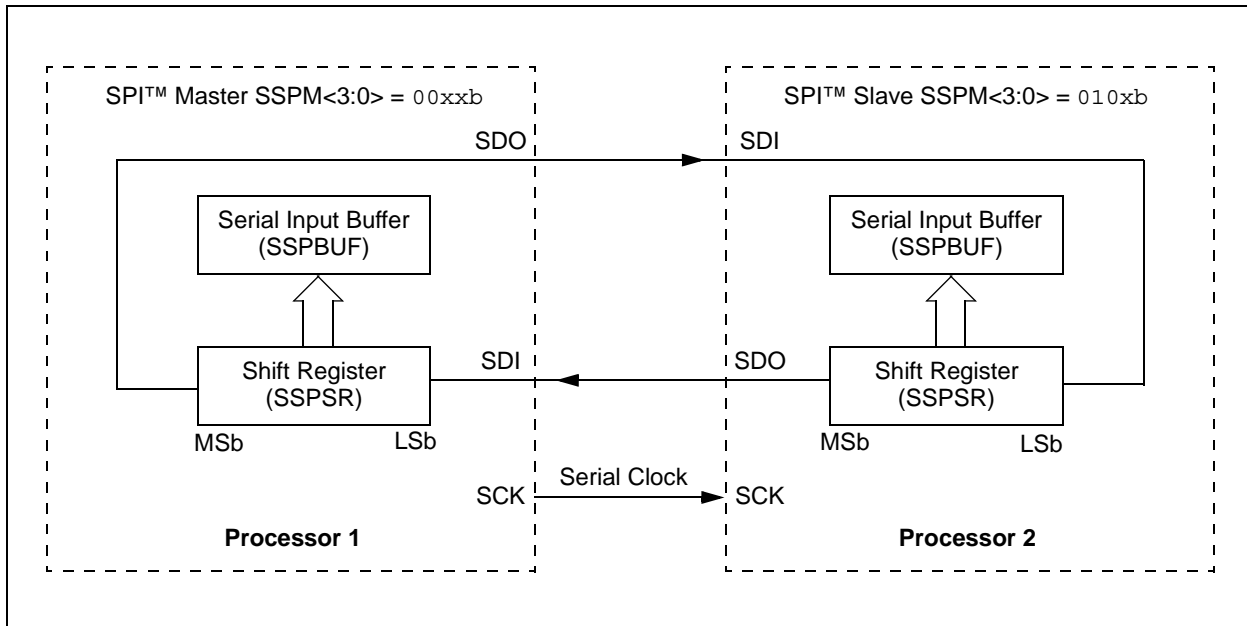

14.5 Master Mode

The master can initiate the data transfer at any time because it controls the SCK. The master determines when the slave (Processor 2, Figure 14-2) is to broadcast data by the software protocol.

In Master mode, the data is transmitted/received as soon as the SSPBUF register is written to. If the SPI is only going to receive, the SDO output could be disabled (programmed as an input). The SSPSR register will continue to shift in the signal present on the SDI pin at the programmed clock rate. As each byte is received, it will be loaded into the SSPBUF register as if a normal received byte (interrupts and Status bits appropriately set). This could be useful in receiver applications as a "Line Activity Monitor" mode.

The clock polarity is selected by appropriately programming the CKP bit (SSPCON<4>). This then, would give waveforms for SPI communication as shown in

Figure 14-3, Figure 14-5 and Figure 14-6, where the MSB is transmitted first. In Master mode, the SPI clock rate (bit rate) is user programmable to be one of the following:

- FOSC/4 (or TCY)
- FOSC/16 (or 4 • TCY)
- FOSC/64 (or 16 • TCY)
- Timer2 output/2

This allows a maximum data rate (at 40 MHz) of 10 Mbps.

Figure 14-3 shows the waveforms for Master mode. When the CKE bit is set, the SDO data is valid before there is a clock edge on SCK. The change of the input sample is shown based on the state of the SMP bit. The time when the SSPBUF is loaded with the received data is shown.

FIGURE 14-3: SPI™ MODE WAVEFORM (MASTER MODE)

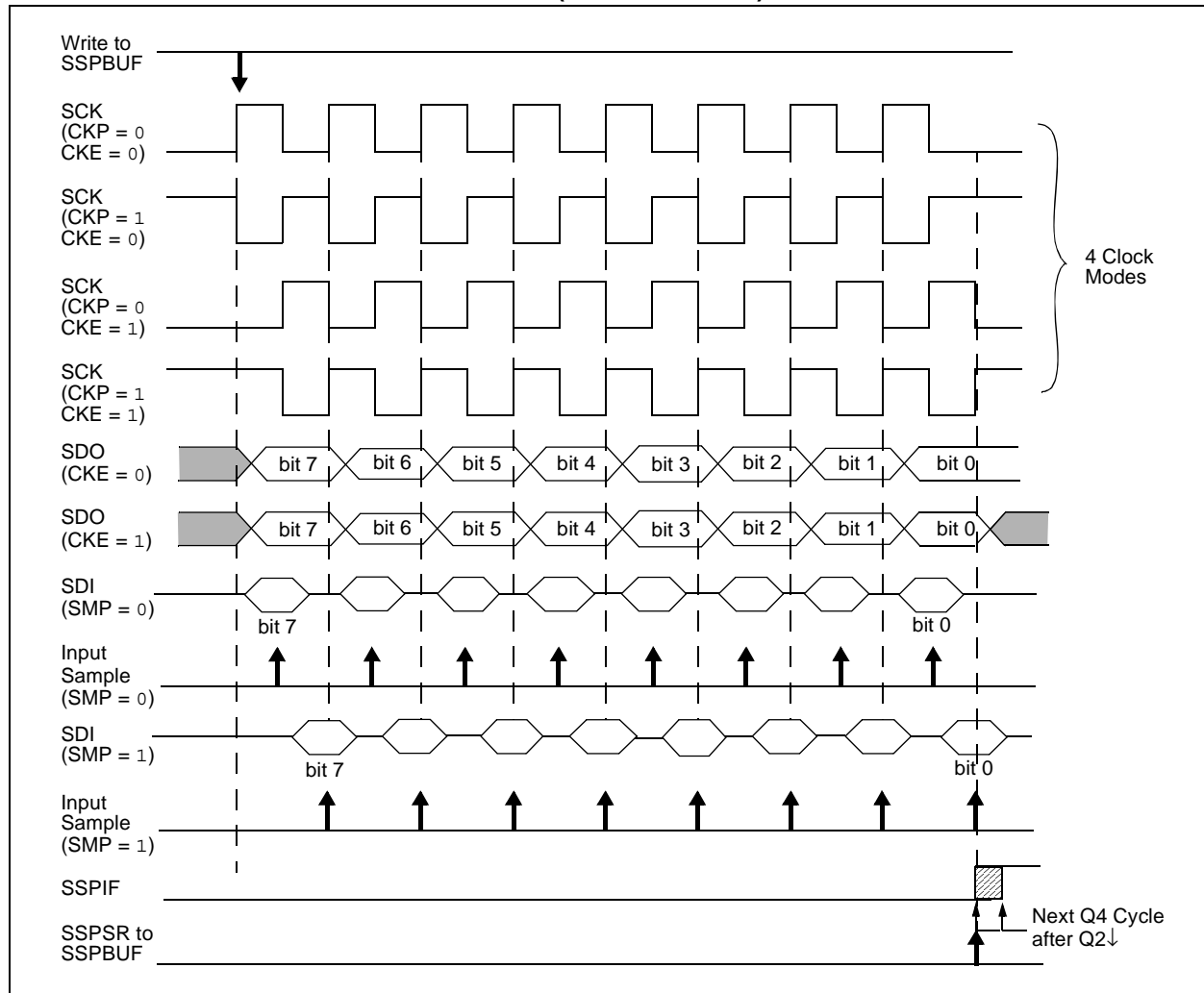

PIC16F917/916/914/913

14.6 Slave Mode

In Slave mode, the data is transmitted and received as the external clock pulses appear on SCK. When the last bit is latched, the SSPIF interrupt flag bit is set.

While in Slave mode, the external clock is supplied by the external clock source on the SCK pin. This external clock must meet the minimum high and low times as specified in the electrical specifications.

While in Sleep mode, the slave can transmit/receive data. When a byte is received, the device will wake-up from Sleep.

14.7 Slave Select Synchronization

The \overline{SS} pin allows a Synchronous Slave mode. The SPI must be in Slave mode with \overline{SS} pin control enabled (SSPCON<3:0> = 04h). The pin must not be driven low for the \overline{SS} pin to function as an input. The data latch must be high. When the \overline{SS} pin is low, transmission and reception are enabled and the SDO pin is driven. When the \overline{SS} pin goes high, the SDO pin is no longer driven, even if in the middle of a transmitted byte, and

becomes a floating output. External pull-up/pull-down resistors may be desirable, depending on the application.

Note 1: When the SPI is in Slave mode with \overline{SS} pin control enabled (SSPCON<3:0> = 0100), the SPI module will reset if the \overline{SS} pin is set to VDD.

2: If the SPI is used in Slave Mode with CKE set, then the \overline{SS} pin control must be enabled.

When the SPI module resets, the bit counter is forced to '0'. This can be done by either forcing the \overline{SS} pin to a high level or clearing the SSPEN bit.

To emulate two-wire communication, the SDO pin can be connected to the SDI pin. When the SPI needs to operate as a receiver, the SDO pin can be configured as an input. This disables transmissions from the SDO. The SDI can always be left as an input (SDI function) since it cannot create a bus conflict.

FIGURE 14-4: SLAVE SYNCHRONIZATION WAVEFORM

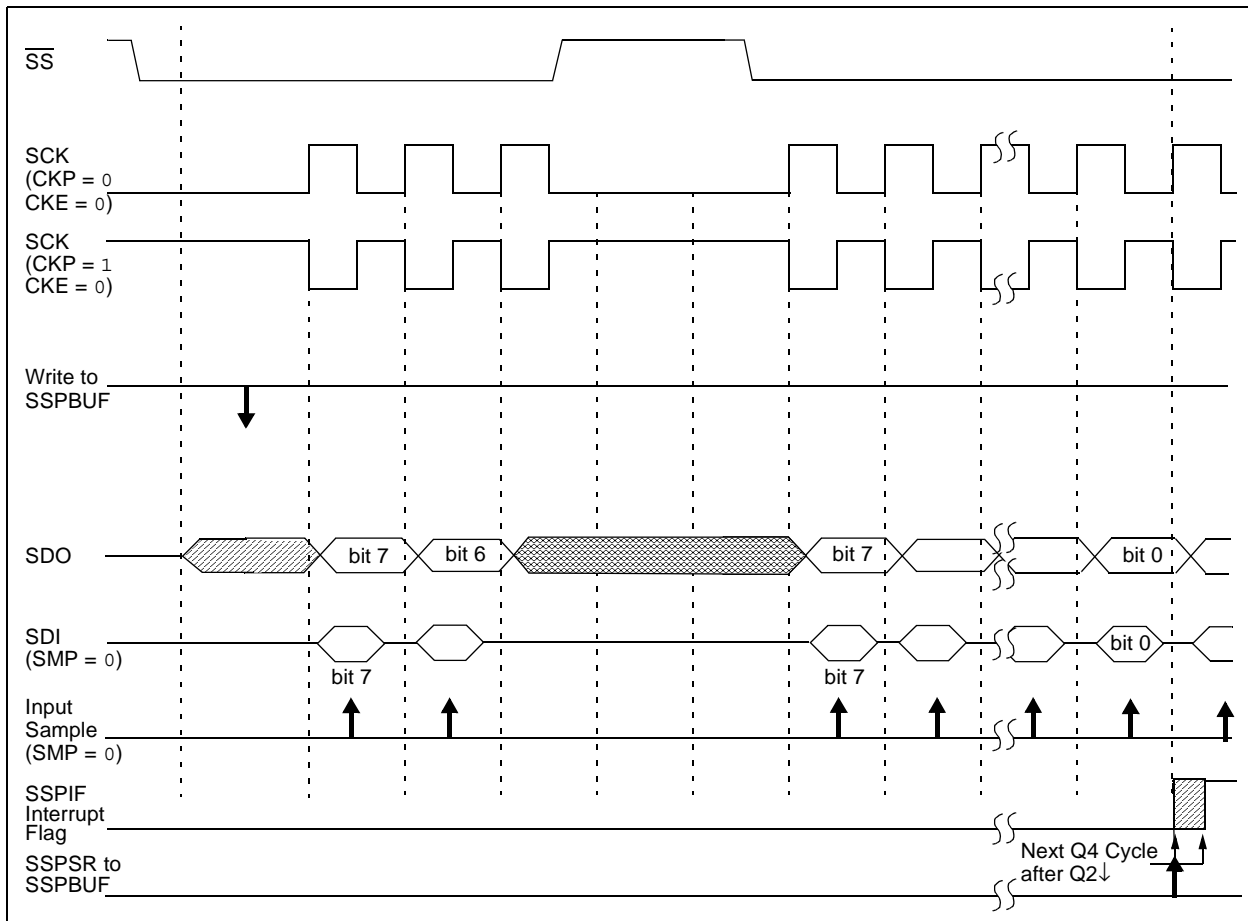

FIGURE 14-5: SPI™ MODE WAVEFORM (SLAVE MODE WITH CKE = 0)

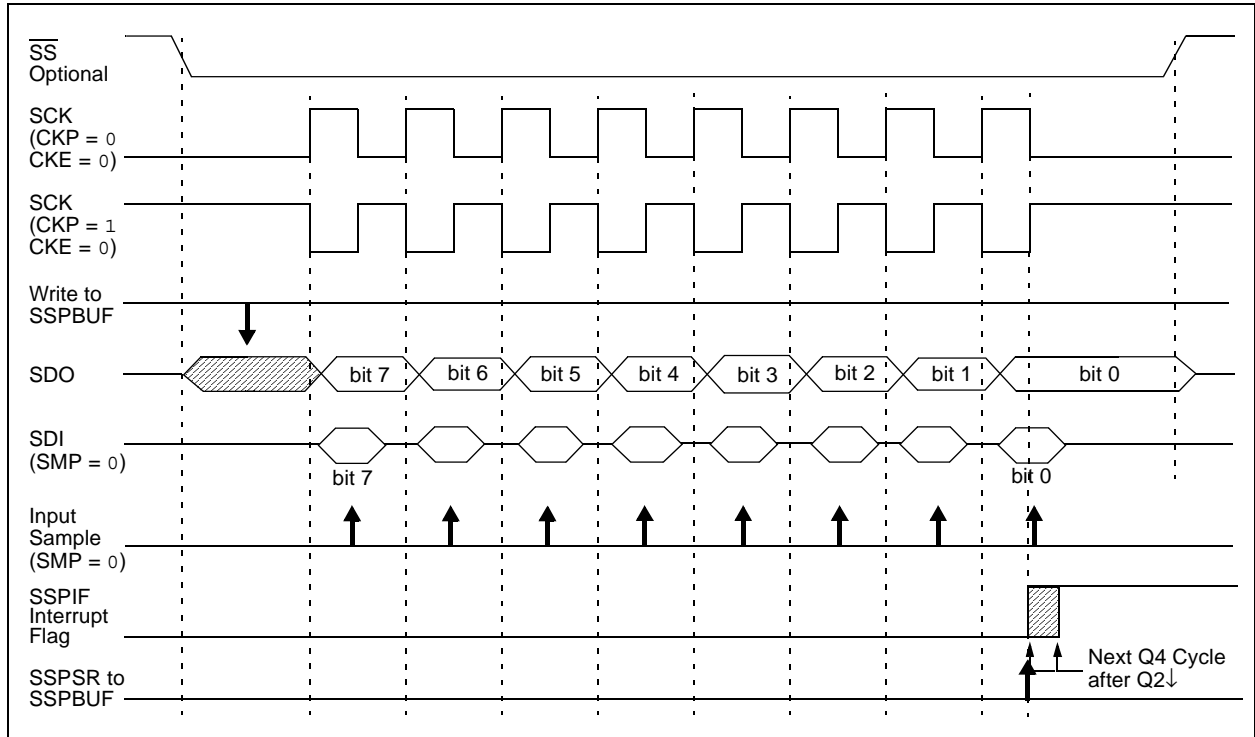
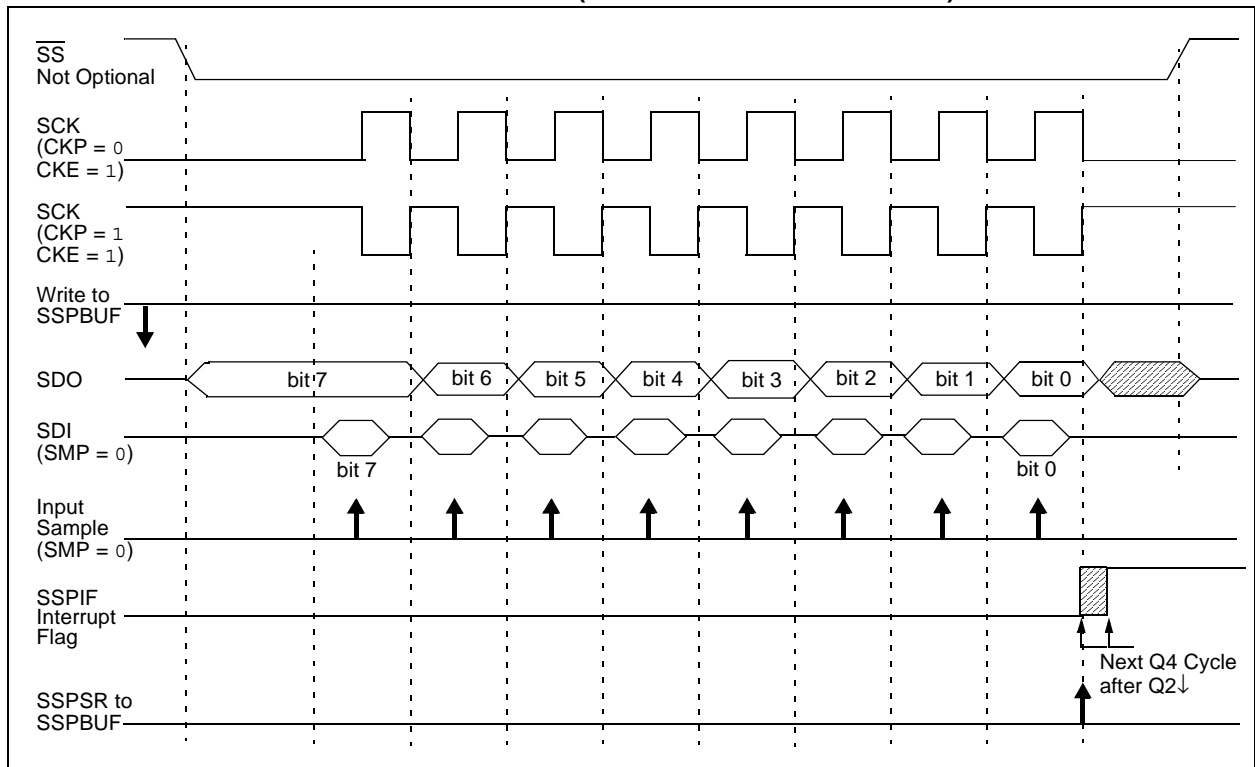

FIGURE 14-6: SPI™ MODE WAVEFORM (SLAVE MODE WITH CKE = 1)



PIC16F917/916/914/913

14.8 Sleep Operation

In Master mode, all module clocks are halted and the transmission/reception will remain in that state until the device wakes from Sleep. After the device returns to normal mode, the module will continue to transmit/receive data.

In Slave mode, the SPI Transmit/Receive Shift register operates asynchronously to the device. This allows the device to be placed in Sleep mode and data to be shifted into the SPI Transmit/Receive Shift register. When all 8 bits have been received, the SSP interrupt flag bit will be set and if enabled, will wake the device from Sleep.

14.9 Effects of a Reset

A Reset disables the SSP module and terminates the current transfer.

14.10 Bus Mode Compatibility

Table 14-1 shows the compatibility between the standard SPI modes and the states of the CKP and CKE control bits.

TABLE 14-1: SPI™ BUS MODES

Standard SPI™ Mode Terminology	Control Bits State	
	CKP	CKE
0, 0	0	1
0, 1	0	0
1, 0	1	1
1, 1	1	0

There is also a SMP bit which controls when the data is sampled.

TABLE 14-2: REGISTERS ASSOCIATED WITH SPI™ OPERATION

Address	Name	Bit 7	Bit 6	Bit 5	Bit 4	Bit 3	Bit 2	Bit 1	Bit 0	Value on: POR, BOR	Value on all other Resets
0Bh,8Bh, 10Bh,18Bh	INTCON	GIE	PEIE	T0IE	INTE	RBIE	T0IF	INTF	RBIF	0000 000x	0000 000x
0Ch	PIR1	EEIF	ADIF	RCIF	TXIF	SSPIF	CCP1IF	TMR2IF	TMR1IF	0000 0000	0000 0000
13h	SSPBUF	Synchronous Serial Port Receive Buffer/Transmit Register								xxxx xxxx	uuuu uuuu
14h	SSPCON	WCOL	SSPOV	SSPEN	CKP	SSPM3	SSPM2	SSPM1	SSPM0	0000 0000	0000 0000
87h	TRISC	TRISC7	TRISC6	TRISC5	TRISC4	TRISC3	TRISC2	TRISC1	TRISC0	1111 1111	1111 1111
8Ch	PIE1	EEIE	ADIE	RCIE	TXIE	SSPIE	CCP1IE	TMR2IE	TMR1IE	0000 0000	0000 0000
85h	TRISA	TRISA7	TRISA6	TRISA5	TRISA4	TRISA3	TRISA2	TRISA1	TRISA0	1111 1111	1111 1111
94h	SSPSTAT	SMP	CKE	D/Ā	P	S	R/W	UA	BF	0000 0000	0000 0000

Legend: x = unknown, u = unchanged, - = unimplemented, read as '0'. Shaded cells are not used by the SSP in SPI mode.

14.11 SSP I²C Operation

The SSP module in I²C mode, fully implements all slave functions, except general call support, and provides interrupts on Start and Stop bits in hardware to facilitate firmware implementations of the master functions. The SSP module implements the Standard mode specifications, as well as 7-bit and 10-bit addressing.

Two pins are used for data transfer. These are the RC6/TX/CK/SCK/SCL/SEG9 pin, which is the clock (SCL), and the RC7/RX/DT/SDI/SDA/SEG8 pin, which is the data (SDA).

The SSP module functions are enabled by setting SSP enable bit SSPEN (SSPCON<5>).

FIGURE 14-7: SSP BLOCK DIAGRAM (I²C™ MODE)

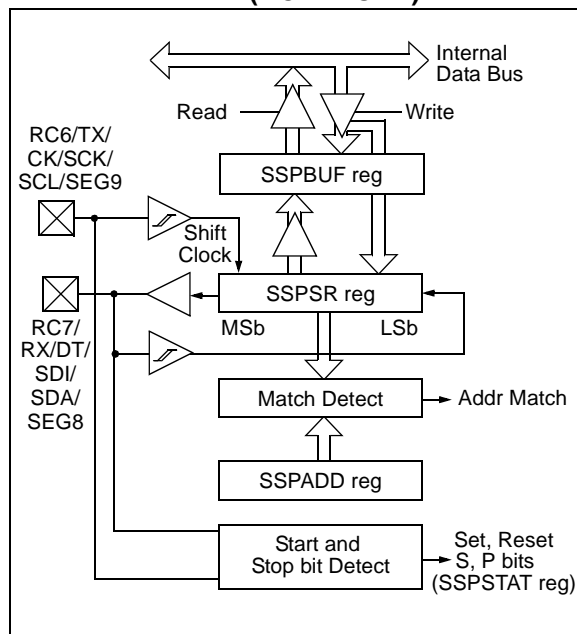

The SSP module has five registers for the I²C operation, which are listed below.

- SSP Control Register (SSPCON)
- SSP Status Register (SSPSTAT)
- Serial Receive/Transmit Buffer (SSPBUF)
- SSP Shift Register (SSPSR) – Not directly accessible
- SSP Address Register (SSPADD)

The SSPCON register allows control of the I²C operation. Four mode selection bits (SSPCON<3:0>) allow one of the following I²C modes to be selected:

- I²C Slave mode (7-bit address)
- I²C Slave mode (10-bit address)
- I²C Slave mode (7-bit address), with Start and Stop bit interrupts enabled to support Firmware Master mode
- I²C Slave mode (10-bit address), with Start and Stop bit interrupts enabled to support Firmware Master mode
- I²C Start and Stop bit interrupts enabled to support Firmware Master mode; Slave is idle

Selection of any I²C mode with the SSPEN bit set forces the SCL and SDA pins to be open drain, provided these pins are programmed to inputs by setting the appropriate TRISC bits. Pull-up resistors must be provided externally to the SCL and SDA pins for proper operation of the I²C module.

Additional information on SSP I²C operation can be found in the "PICmicro® Mid-Range MCU Family Reference Manual" (DS33023).

14.12 Slave Mode

In Slave mode, the SCL and SDA pins must be configured as inputs (TRISC<7:6> set). The SSP module will override the input state with the output data when required (slave-transmitter).

When an address is matched, or the data transfer after an address match is received, the hardware automatically will generate the Acknowledge (ACK) pulse, and then load the SSPBUF register with the received value currently in the SSPSR register.

There are certain conditions that will cause the SSP module not to give this ACK pulse. They include (either or both):

- The buffer full bit BF (SSPSTAT<0>) was set before the transfer was received.
- The overflow bit SSPOV (SSPCON<6>) was set before the transfer was received.

In this case, the SSPSR register value is not loaded into the SSPBUF, but bit SSPIF (PIR1<3>) is set. Table 14-3 shows the results of when a data transfer byte is received, given the status of bits BF and SSPOV. The shaded cells show the condition where user software did not properly clear the overflow condition. Flag bit BF is cleared by reading the SSPBUF register, while bit SSPOV is cleared through software.

The SCL clock input must have a minimum high and low for proper operation. For high and low times of the I²C specification, as well as the requirements of the SSP module, see **Section 19.0 "Electrical Specifications"**.

PIC16F917/916/914/913

14.12.1 ADDRESSING

Once the SSP module has been enabled, it waits for a Start condition to occur. Following the Start condition, the 8-bits are shifted into the SSPSR register. All incoming bits are sampled with the rising edge of the clock (SCL) line. The value of register SSPSR<7:1> is compared to the value of the SSPADD register. The address is compared on the falling edge of the eighth clock (SCL) pulse. If the addresses match, and the BF and SSPOV bits are clear, the following events occur:

- The SSPSR register value is loaded into the SSPBUF register.
- The buffer full bit, BF is set.
- An $\overline{\text{ACK}}$ pulse is generated.
- SSP interrupt flag bit, SSPIF (PIR1<3>) is set (interrupt is generated if enabled) on the falling edge of the ninth SCL pulse.

In 10-bit Address mode, two address bytes need to be received by the slave (Figure 14-8). The five Most Significant bits (MSBs) of the first address byte specify if this is a 10-bit address. Bit R/W (SSPSTAT<2>) must specify a write so the slave device will receive the second address byte. For a 10-bit address, the first byte would equal '1111 0 A9 A8 0', where A9 and A8 are the two MSBs of the address.

The sequence of events for 10-bit address is as follows, with steps 7-9 for slave-transmitter:

- Receive first (high) byte of address (bits SSPIF, BF and bit UA (SSPSTAT<1>) are set).
- Update the SSPADD register with second (low) byte of address (clears bit UA and releases the SCL line).
- Read the SSPBUF register (clears bit BF) and clear flag bit SSPIF.
- Receive second (low) byte of address (bits SSPIF, BF and UA are set).
- Update the SSPADD register with the first (high) byte of address; if match releases SCL line, this will clear bit UA.
- Read the SSPBUF register (clears bit BF) and clear flag bit SSPIF.
- Receive repeated Start condition.
- Receive first (high) byte of address (bits SSPIF and BF are set).
- Read the SSPBUF register (clears bit BF) and clear flag bit SSPIF.

TABLE 14-3: DATA TRANSFER RECEIVED BYTE ACTIONS

Status Bits as Data Transfer is Received		SSPSR → SSPBUF	Generate $\overline{\text{ACK}}$ Pulse	Set bit SSPIF (SSP Interrupt occurs if enabled)
BF	SSPOV			
0	0	Yes	Yes	Yes
1	0	No	No	Yes
1	1	No	No	Yes
0	1	No	No	Yes

Note: Shaded cells show the conditions where the user software did not properly clear the overflow condition.

14.12.2 RECEPTION

When the $\overline{R/\overline{W}}$ bit of the address byte is clear and an address match occurs, the $\overline{R/\overline{W}}$ bit of the SSPSTAT register is cleared. The received address is loaded into the SSPBUF register.

When the address byte overflow condition exists, then no Acknowledge (\overline{ACK}) pulse is given. An overflow condition is defined as either bit BF (SSPSTAT<0>) is set, or bit SSPOV (SSPCON<6>) is set. This is an error condition due to the user's firmware.

An SSP interrupt is generated for each data transfer byte. Flag bit SSPIF (PIR1<3>) must be cleared in software. The SSPSTAT register is used to determine the status of the byte.

FIGURE 14-8: I²C™ WAVEFORMS FOR RECEPTION (7-BIT ADDRESS)

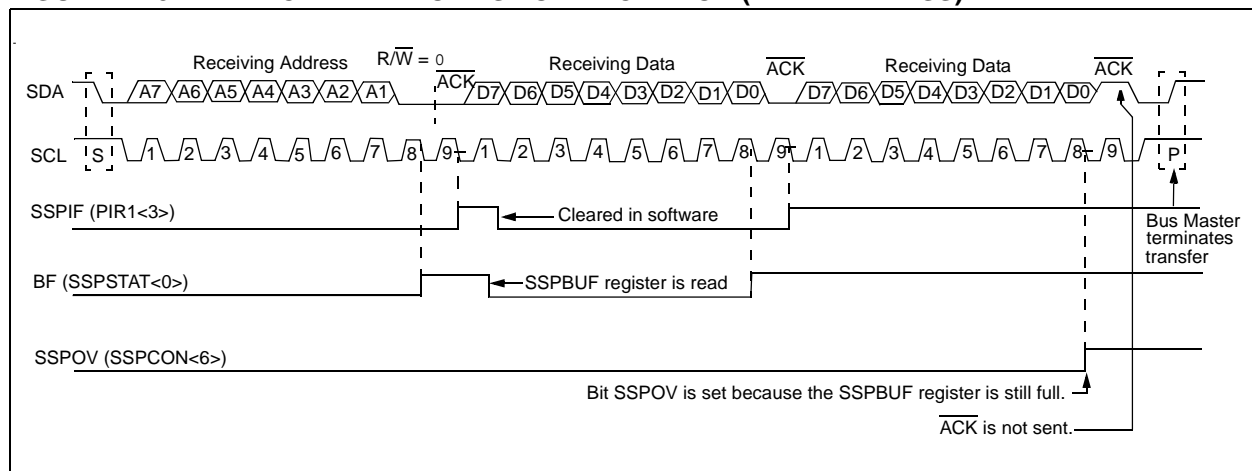

PIC16F917/916/914/913

FIGURE 14-9: I²C™ SLAVE MODE TIMING (RECEPTION, 10-BIT ADDRESS)

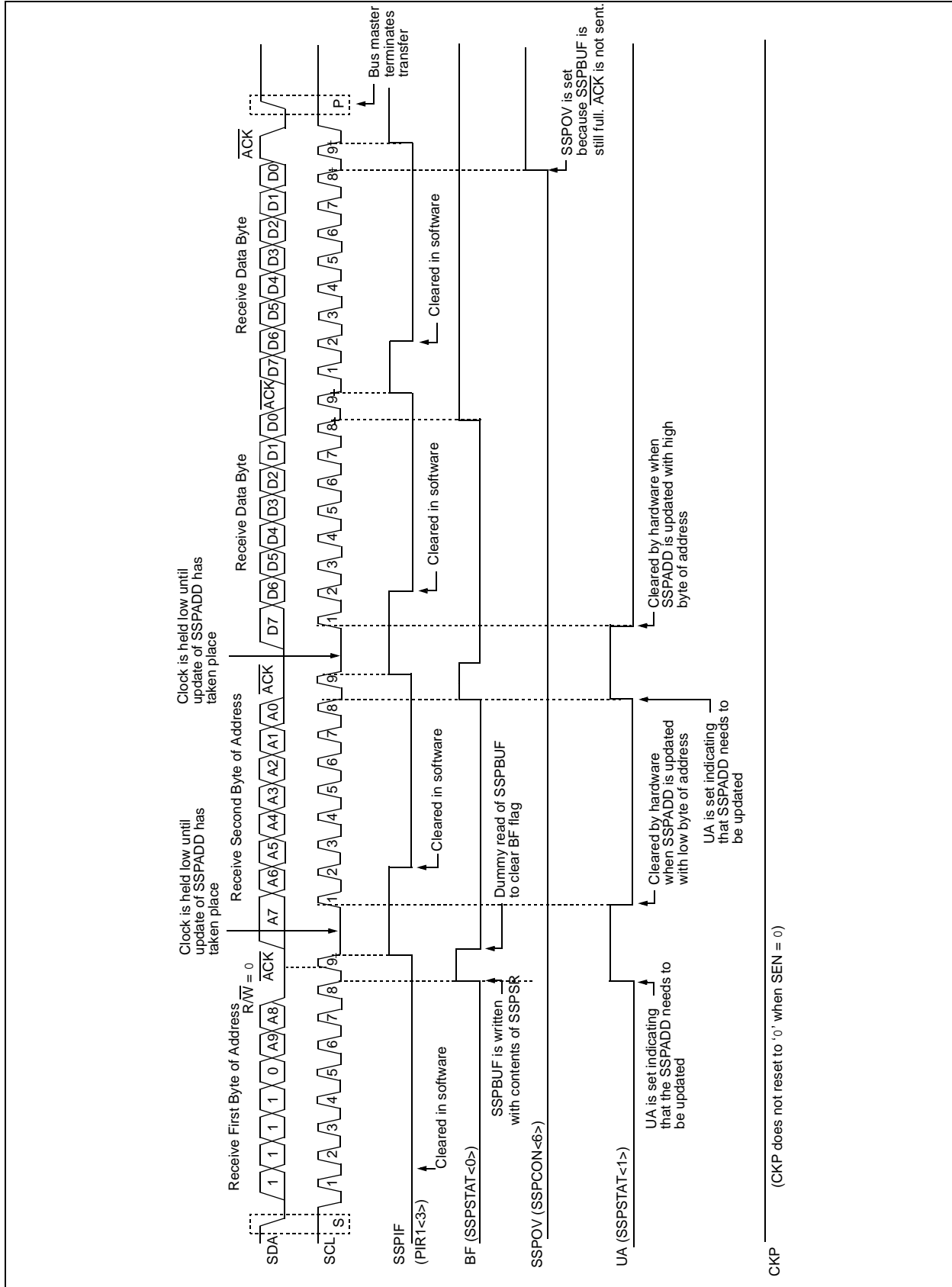

14.12.3 TRANSMISSION

When the $\overline{R/W}$ bit of the incoming address byte is set and an address match occurs, the $\overline{R/W}$ bit of the SSPSTAT register is set. The received address is loaded into the SSPBUF register. The \overline{ACK} pulse will be sent on the ninth bit, and pin RC6/TX/CK/SCK/SCL/SEG9 is held low. The transmit data must be loaded into the SSPBUF register, which also loads the SSPSR register. Then, pin RC6/TX/CK/SCK/SCL/SEG9 should be enabled by setting bit CKP (SSPCON<4>). The master must monitor the SCL pin prior to asserting another clock pulse. The slave devices may be holding off the master by stretching the clock. The eight data bits are shifted out on the falling edge of the SCL input. This ensures that the SDA signal is valid during the SCL high time (Figure 14-10).

An SSP interrupt is generated for each data transfer byte. Flag bit SSPIF must be cleared in software, and the SSPSTAT register is used to determine the status of the byte. Flag bit SSPIF is set on the falling edge of the ninth clock pulse.

As a slave-transmitter, the \overline{ACK} pulse from the master receiver is latched on the rising edge of the ninth SCL input pulse. If the SDA line was high (not \overline{ACK}), then the data transfer is complete. When the \overline{ACK} is latched by the slave, the slave logic is reset (resets SSPSTAT register) and the slave then monitors for another occurrence of the Start bit. If the SDA line was low (\overline{ACK}), the transmit data must be loaded into the SSPBUF register, which also loads the SSPSR register. Then pin RC6/TX/CK/SCK/SCL/SEG9 should be enabled by setting bit CKP.

FIGURE 14-10: I²C™ WAVEFORMS FOR TRANSMISSION (7-BIT ADDRESS)

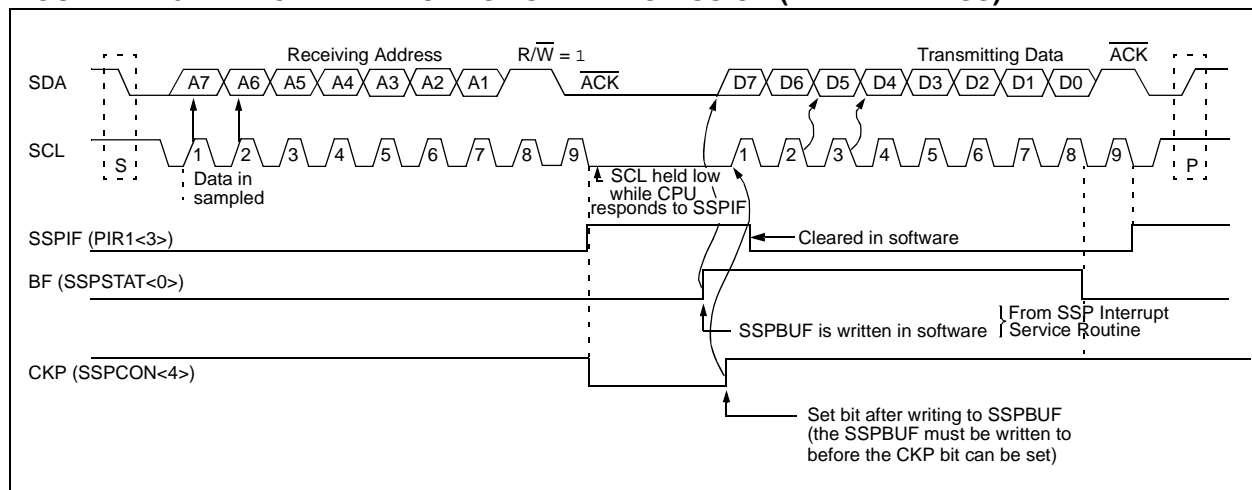

PIC16F917/916/914/913

FIGURE 14-11: I²C™ SLAVE MODE TIMING (TRANSMISSION, 10-BIT ADDRESS)

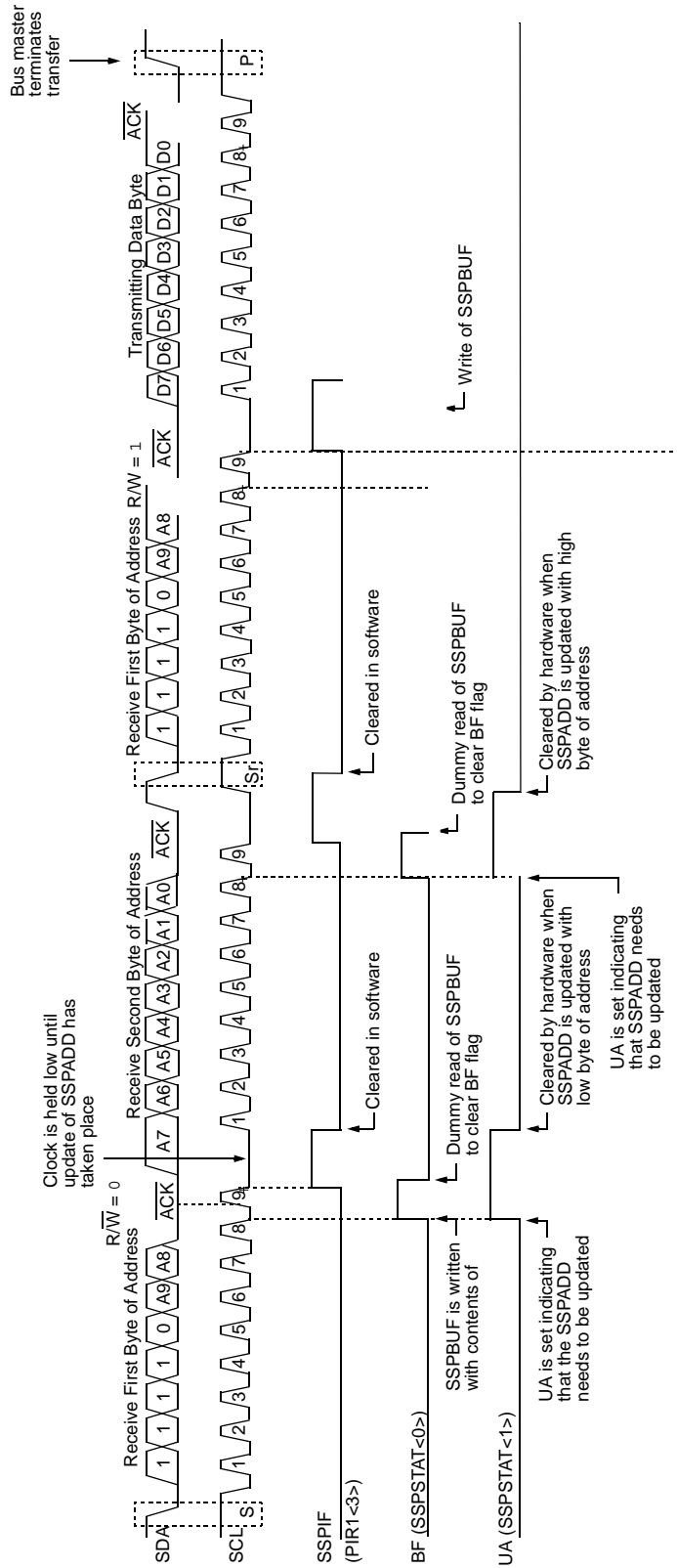

14.13 Master Mode

Master mode of operation is supported in firmware using interrupt generation on the detection of the Start and Stop conditions. The Stop (P) and Start (S) bits are cleared from a Reset or when the SSP module is disabled. The Stop (P) and Start (S) bits will toggle based on the Start and Stop conditions. Control of the I²C bus may be taken when the P bit is set or the bus is idle and both the S and P bits are clear.

In Master mode, the SCL and SDA lines are manipulated by clearing the corresponding TRISC<6:7> bit(s). The output level is always low, irrespective of the value(s) in PORTC<6:7>. So when transmitting data, a '1' data bit must have the TRISC<7> bit set (input) and a '0' data bit must have the TRISC<7> bit cleared (output). The same scenario is true for the SCL line with the TRISC<6> bit. Pull-up resistors must be provided externally to the SCL and SDA pins for proper operation of the I²C module.

The following events will cause the SSP Interrupt Flag bit, SSPIF, to be set (SSP Interrupt will occur if enabled):

- Start condition
- Stop condition
- Data transfer byte transmitted/received

Master mode of operation can be done with either the Slave mode idle (SSPM<3:0> = 1011), or with the Slave active. When both Master and Slave modes are enabled, the software needs to differentiate the source(s) of the interrupt.

14.14 Multi-Master Mode

In Multi-Master mode, the interrupt generation on the detection of the Start and Stop conditions, allows the determination of when the bus is free. The Stop (P) and Start (S) bits are cleared from a Reset or when the SSP module is disabled. The Stop (P) and Start (S) bits will toggle based on the Start and Stop conditions. Control of the I²C bus may be taken when bit P (SSPSTAT<4>) is set, or the bus is idle and both the S and P bits clear. When the bus is busy, enabling the SSP Interrupt will generate the interrupt when the Stop condition occurs.

In Multi-Master operation, the SDA line must be monitored to see if the signal level is the expected output level. This check only needs to be done when a high level is output. If a high level is expected and a low level is present, the device needs to release the SDA and SCL lines (set TRISC<6:7>). There are two stages where this arbitration can be lost, these are:

- Address Transfer
- Data Transfer

When the slave logic is enabled, the slave continues to receive. If arbitration was lost during the address transfer stage, communication to the device may be in progress. If addressed, an ACK pulse will be generated. If arbitration was lost during the data transfer stage, the device will need to re-transfer the data at a later time.

14.14.1 CLOCK SYNCHRONIZATION AND THE CKP BIT

When the CKP bit is cleared, the SCL output is forced to '0'; however, setting the CKP bit will not assert the SCL output low until the SCL output is already sampled low. Therefore, the CKP bit will not assert the SCL line until an external I²C master device has already asserted the SCL line. The SCL output will remain low until the CKP bit is set and all other devices on the I²C bus have deasserted SCL. This ensures that a write to the CKP bit will not violate the minimum high time requirement for SCL (see Figure 14-12).

PIC16F917/916/914/913

FIGURE 14-12: CLOCK SYNCHRONIZATION TIMING

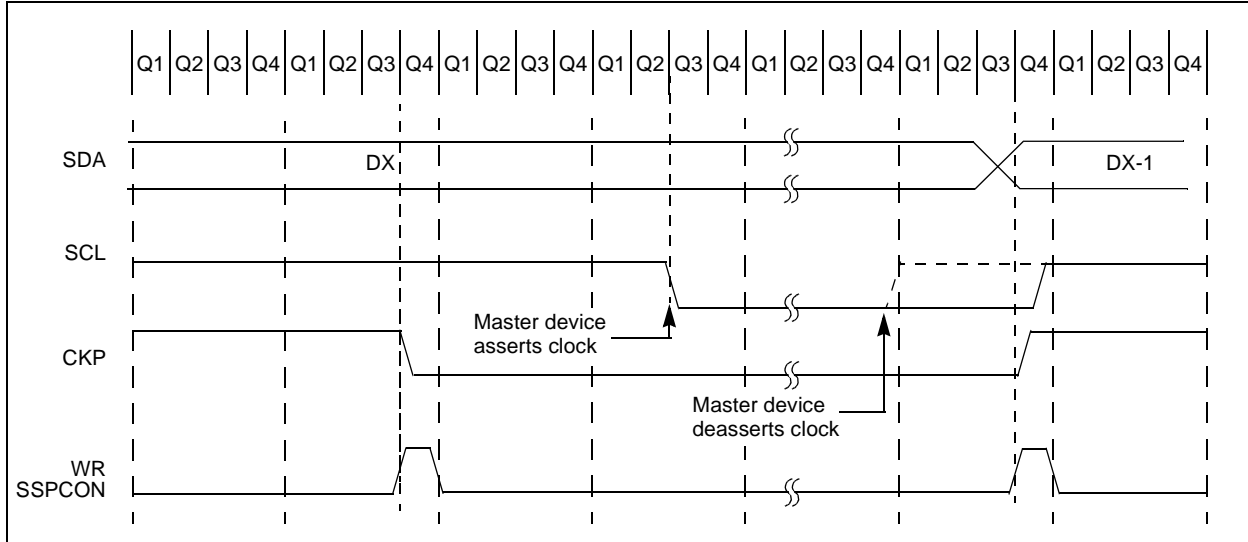

TABLE 14-4: REGISTERS ASSOCIATED WITH I²C™ OPERATION

Address	Name	Bit 7	Bit 6	Bit 5	Bit 4	Bit 3	Bit 2	Bit 1	Bit 0	Value on: POR, BOR	Value on all other Resets
0Bh, 8Bh, 10Bh,18Bh	INTCON	GIE	PEIE	TOIE	INTE	RBIE	TOIF	INTF	RBIF	0000 000x	0000 000x
0Ch	PIR1	EEIF	ADIF	RCIF	TXIF	SSPIF	CCP1IF	TMR2IF	TMR1IF	0000 0000	0000 0000
8Ch	PIE1	EEIE	ADIE	RCIE	TXIE	SSPIE	CCP1IE	TMR2IE	TMR1IE	0000 0000	0000 0000
13h	SSPBUF	Synchronous Serial Port Receive Buffer/Transmit Register								xxxx xxxx	uuuu uuuu
14h	SSPCON	WCOL	SSPOV	SSPEN	CKP	SSPM3	SSPM2	SSPM1	SSPM0	0000 0000	0000 0000
87h	TRISC	PORTC Data Direction Register								1111 1111	1111 1111
93h	SSPAD	Synchronous Serial Port (I ² C™ mode) Address Register								0000 0000	0000 0000
94h	SSPSTAT	SMP ⁽¹⁾	CKE ⁽¹⁾	D/A	P	S	R/W	UA	BF	0000 0000	0000 0000

Legend: x = unknown, u = unchanged, - = unimplemented locations read as '0'. Shaded cells are not used by SSP module in I²C mode.

Note 1: Maintain these bits clear in I²C mode.

15.0 CAPTURE/COMPARE/PWM MODULES

Each Capture/Compare/PWM (CCP) module contains a 16-bit register which can operate as a:

- 16-bit Capture register
- 16-bit Compare register
- PWM Master/Slave Duty Cycle register

Both the CCP1 and CCP2 modules are identical in operation, with the exception being the operation of the special event trigger. Table 15-1 and Table 15-2 show the resources and interactions of the CCP module(s). In the following sections, the operation of a CCP module is described with respect to CCP1. CCP2 operates the same as CCP1, except where noted.

CCP1 Module:

Capture/Compare/PWM Register1 (CCPR1) is comprised of two 8-bit registers: CCPR1L (low byte) and CCPR1H (high byte). The CCP1CON register controls the operation of CCP1. The special event trigger is generated by a compare match and will reset Timer1.

CCP2 Module:

Capture/Compare/PWM Register2 (CCPR2) is comprised of two 8-bit registers: CCPR2L (low byte) and CCPR2H (high byte). The CCP2CON register controls the operation of CCP2. The special event trigger is generated by a compare match and will reset Timer1 and start an A/D conversion (if the A/D module is enabled).

Additional information on CCP modules is available in the "PICmicro® Mid-Range MCU Family Reference Manual" (DS33023) and in Application Note AN594, "Using the CCP Modules" (DS00594).

TABLE 15-1: CCP MODE – TIMER RESOURCES REQUIRED

CCP Mode	Timer Resource
Capture	Timer1
Compare	Timer1
PWM	Timer2

TABLE 15-2: INTERACTION OF TWO CCP MODULES

CCPx Mode	CCPy Mode	Interaction
Capture	Capture	Same TMR1 time base
Capture	Compare	The compare should be configured for the special event trigger, which clears TMR1
Compare	Compare	The compare(s) should be configured for the special event trigger, which clears TMR1
PWM	PWM	The PWMs will have the same frequency and update rate (TMR2 interrupt)
PWM	Capture	None
PWM	Compare	None

PIC16F917/916/914/913

REGISTER 15-1: CCP1CON – CCP2CON⁽¹⁾ REGISTER (ADDRESS: 17h/1Dh)

U-0	U-0	R/W-0	R/W-0	R/W-0	R/W-0	R/W-0	R/W-0	
—	—	CCPxX	CCPxY	CCPxM3	CCPxM2	CCPxM1	CCPxM0	
bit 7								bit 0

bit 7-6 **Unimplemented:** Read as '0'

bit 5-4 **CCPxX:CCPxY:** PWM Least Significant bits

Capture mode:

Unused

Compare mode:

Unused

PWM mode:

These bits are the two LSBs of the PWM duty cycle. The eight MSBs are found in CCPRxL.

bit 3-0 **CCPxM<3:0>:** CCPx Mode Select bits

0000 = Capture/Compare/PWM disabled (resets CCPx module)

0100 = Capture mode, every falling edge

0101 = Capture mode, every rising edge

0110 = Capture mode, every 4th rising edge

0111 = Capture mode, every 16th rising edge

1000 = Compare mode, set output on match (CCPxIF bit is set)

1001 = Compare mode, clear output on match (CCPxIF bit is set)

1010 = Compare mode, generate software interrupt on match (CCPxIF bit is set, CCPx pin is unaffected)

1011 = Compare mode, trigger special event (CCPxIF bit is set, CCPx pin is unaffected); CCP1 resets TMR1; CCP2 resets TMR1 and starts an A/D conversion (if A/D module is enabled)

11xx = PWM mode

Note 1: CCP2CON used for PIC16F914/917 only.

Legend:

R = Readable bit

W = Writable bit

U = Unimplemented bit, read as '0'

- n = Value at POR

'1' = Bit is set

'0' = Bit is cleared

x = Bit is unknown

15.1 Capture Mode

In Capture mode, CCPR1H:CCPR1L captures the 16-bit value of the TMR1 register when an event occurs on pin RC5/T1CKI/CCP1/SEG10. An event is defined as one of the following:

- Every falling edge
- Every rising edge
- Every 4th rising edge
- Every 16th rising edge

The type of event is configured by control bits CCP1M<3:0> (CCPxCON<3:0>). When a capture is made, the interrupt request flag bit CCP1IF (PIR1<2>) is set. The interrupt flag must be cleared in software. If another capture occurs before the value in register CCPR1 is read, the old captured value is overwritten by the new value.

15.1.1 CCP PIN CONFIGURATION

In Capture mode, the RC5/T1CKI/CCP1/SEG10 pin should be configured as an input by setting the TRISC<5> bit.

Note: If the RC5/T1CKI/CCP1/SEG10 pin is configured as an output, a write to the port can cause a capture condition.

15.1.4 CCP PRESCALER

There are four prescaler settings, specified by bits CCP1M<3:0>. Whenever the CCP module is turned off, or the CCP module is not in Capture mode, the prescaler counter is cleared. Any Reset will clear the prescaler counter.

Switching from one capture prescaler to another may generate an interrupt. Also, the prescaler counter will not be cleared, therefore, the first capture may be from a non-zero prescaler. Example 15-1 shows the recommended method for switching between capture prescalers. This example also clears the prescaler counter and will not generate the “false” interrupt.

EXAMPLE 15-1: CHANGING BETWEEN CAPTURE PRESCALERS

FIGURE 15-3: CAPTURE MODE OPERATION BLOCK DIAGRAM

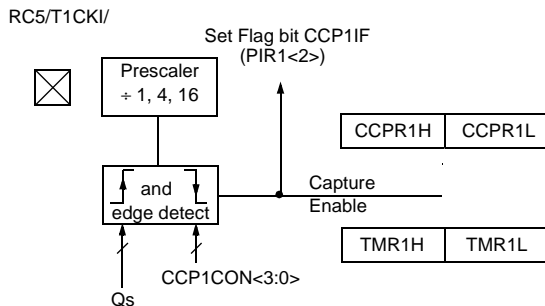

15.1.2 TIMER1 MODE SELECTION

Timer1 must be running in Timer mode, or Synchronized Counter mode, for the CCP module to use the capture feature. In Asynchronous Counter mode, the capture operation may not work.

15.1.3 SOFTWARE INTERRUPT

When the Capture mode is changed, a false capture interrupt may be generated. The user should keep bit CCP1IE (PIE1<2>) clear to avoid false interrupts and should clear the flag bit CCP1IF, following any such change in Operating mode.

PIC16F917/916/914/913

15.2 Compare Mode

In Compare mode, the 16-bit CCPR1 register value is constantly compared against the TMR1 register pair value. When a match occurs, the RC5/T1CKI/CCP1/SEG10 pin is:

- Driven high
- Driven low
- Remains unchanged

The action on the pin is based on the value of control bits CCP1M<3:0> (CCP1CON<3:0>). At the same time, interrupt flag bit CCP1IF is set.

FIGURE 15-4: COMPARE MODE OPERATION BLOCK DIAGRAM

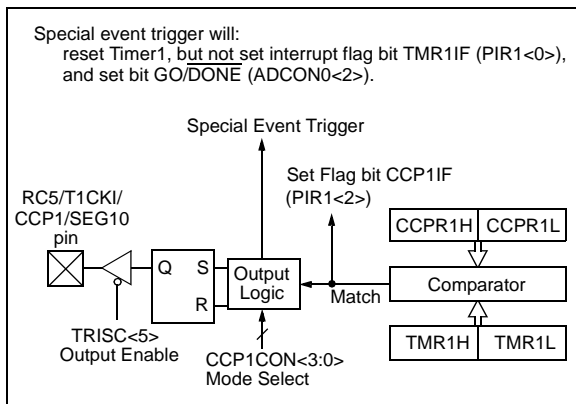

15.2.1 CCP PIN CONFIGURATION

The user must configure the RC5/T1CKI/CCP1/SEG10 pin as an output by clearing the TRISC<5> bit.

Note: Clearing the CCP1CON register will force the RC5/T1CKI/CCP1/SEG10 compare output latch to the default low level. This is not the PORTC I/O data latch.

15.2.2 TIMER1 MODE SELECTION

Timer1 must be running in Timer mode, or Synchronized Counter mode, if the CCP module is using the compare feature. In Asynchronous Counter mode, the compare operation may not work.

15.2.3 SOFTWARE INTERRUPT MODE

When Generate Software Interrupt mode is chosen, the RC5/T1CKI/CCP1/SEG10 pin is not affected. The CCP1IF bit is set, causing a CCP interrupt (if enabled).

15.2.4 SPECIAL EVENT TRIGGER

In this mode, an internal hardware trigger is generated, which may be used to initiate an action.

The special event trigger output of CCP1 resets the TMR1 register pair. This allows the CCPR1 register to effectively be a 16-bit programmable period register for Timer1.

The special event trigger output of CCP2 resets the TMR1 register pair and starts an A/D conversion (if the A/D module is enabled).

Note: The special event trigger from the CCP1 and CCP2 modules will not set interrupt flag bit TMR1IF (PIR1<0>).

15.3 PWM Mode (PWM)

In Pulse Width Modulation mode, the CCPx pin produces up to a 10-bit resolution PWM output. Since the RC5/T1CKI/CCP1/SEG10 pin is multiplexed with the PORTC data latch, the TRISC<5> bit must be cleared to make the RC5/T1CKI/CCP1/SEG10 pin an output.

Note: Clearing the CCP1CON register will force the CCP1 PWM output latch to the default low level. This is not the PORTC I/O data latch.

Figure 15-5 shows a simplified block diagram of the CCP module in PWM mode.

For a step-by-step procedure on how to set up the CCP module for PWM operation, see **Section 15.3.3 "Setup for PWM Operation"**.

FIGURE 15-5: SIMPLIFIED PWM BLOCK DIAGRAM

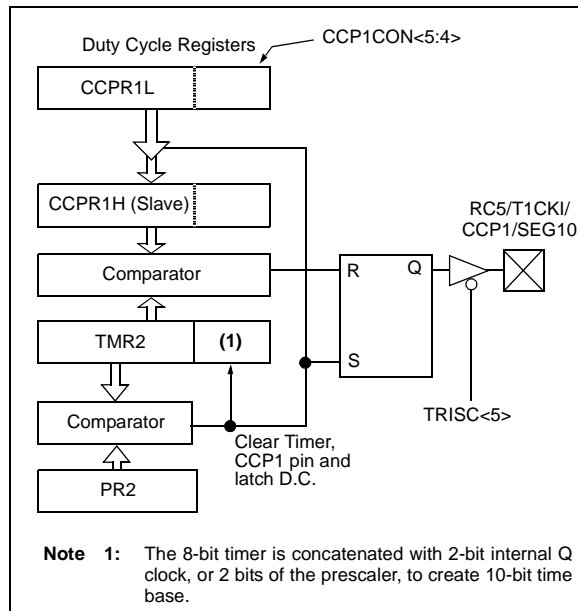

A PWM output (Figure 15-6) has a time base (period) and a time that the output stays high (duty cycle). The frequency of the PWM is the inverse of the period (1/period).

FIGURE 15-6: PWM OUTPUT

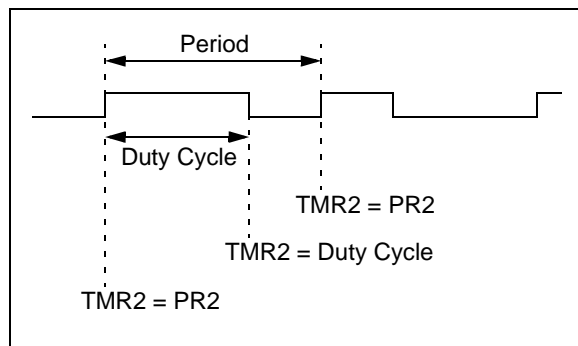

15.3.1 PWM PERIOD

The PWM period is specified by writing to the PR2 register. The PWM period can be calculated using the following formula:

$$\text{PWM period} = (\text{PR2} + 1) \cdot 4 \cdot \text{Tosc} \cdot (\text{TMR2 prescale value})$$

PWM frequency is defined as $1/[\text{PWM period}]$.

When TMR2 is equal to PR2, the following three events occur on the next increment cycle:

- TMR2 is cleared
- The RC5/T1CKI/CCP1/SEG10 pin is set (exception: if PWM duty cycle = 0%, the RC5/T1CKI/CCP1/SEG10 pin will not be set)
- The PWM duty cycle is latched from CCPR1L into CCPR1H

Note: The Timer2 postscaler (see **Section 7.0 "Timer2 Module"**) is not used in the determination of the PWM frequency. The postscaler could be used to have a servo update rate at a different frequency than the PWM output.

15.3.2 PWM DUTY CYCLE

The PWM duty cycle is specified by writing to the CCPR1L register and to the CCP1CON<5:4> bits. Up to 10-bit resolution is available. The CCPR1L contains the eight MSbs and the CCP1CON<5:4> contains the two LSbs. This 10-bit value is represented by CCPR1L:CCP1CON<5:4>. The following equation is used to calculate the PWM duty cycle in time:

$$\text{PWM duty cycle} = (\text{CCPR1L:CCP1CON<5:4>}) \cdot \text{Tosc} \cdot (\text{TMR2 prescale value})$$

CCPR1L and CCP1CON<5:4> can be written to at any time, but the duty cycle value is not latched into CCPR1H until after a match between PR2 and TMR2 occurs (i.e., the period is complete). In PWM mode, CCPR1H is a read-only register.

The CCPR1H register and a 2-bit internal latch are used to double buffer the PWM duty cycle. This double buffering is essential for glitch-free PWM operation.

When the CCPR1H and 2-bit latch match TMR2, concatenated with an internal 2-bit Q clock, or 2 bits of the TMR2 prescaler, the CCP1 pin is cleared.

The maximum PWM resolution (bits) for a given PWM frequency is given by the formula:

$$\text{PWM Resolution} = \frac{\log\left(\frac{F_{\text{OSC}}}{F_{\text{PWM}} \times \text{TMR2 Prescaler}}\right)}{\log(2)} \text{ bits}$$

Note: If the PWM duty cycle value is longer than the PWM period, the RC5/T1CKI/CCP1/SEG10 pin will not be cleared.

PIC16F917/916/914/913

15.3.3 SETUP FOR PWM OPERATION

The following steps should be taken when configuring the CCP module for PWM operation:

1. Set the PWM period by writing to the PR2 register.
2. Set the PWM duty cycle by writing to the CCPR1L register and CCP1CON<5:4> bits.
3. Make the RC5/T1CKI/CCP1/SEG10 pin an output by clearing the TRISC<5> bit.
4. Set the TMR2 prescale value and enable Timer2 by writing to T2CON.
5. Configure the CCP1 module for PWM operation.

TABLE 15-1: EXAMPLE PWM FREQUENCIES AND RESOLUTIONS AT 20 MHz

PWM Frequency	1.22 kHz	4.88 kHz	19.53 kHz	78.12kHz	156.3 kHz	208.3 kHz
Timer Prescaler (1, 4, 16)	16	4	1	1	1	1
PR2 Value	0xFFh	0xFFh	0xFFh	0x3Fh	0x1Fh	0x17h
Maximum Resolution (bits)	10	10	10	8	7	5.5

TABLE 15-2: REGISTERS ASSOCIATED WITH CAPTURE, COMPARE AND TIMER1

Address	Name	Bit 7	Bit 6	Bit 5	Bit 4	Bit 3	Bit 2	Bit 1	Bit 0	Value on: POR, BOR	Value on all other Resets
0Bh, 8Bh, 10Bh, 18Bh	INTCON	GIE	PEIE	T0IE	INTE	RBIE	T0IF	INTF	RBIF	0000 000x	0000 000x
0Ch	PIR1	EEIF	ADIF	RCIF	TXIF	SSPIF	CCP1IF	TMR2IF	TMR1IF	0000 0000	0000 0000
0Dh	PIR2	OSFIF	C2IF	C1IF	LCDIF	—	LVDIF	—	CCP2IF	0000 -0-0	0000 -0-0
8Ch	PIE1	EEIE	ADIE	RCIE	TXIE	SSPIE	CCP1IE	TMR2IE	TMR1IE	0000 0000	0000 0000
8Dh	PIE2	OSFIE	C2IE	C1IE	LCDIE	—	LVDIE	—	CCP2IE	0000 -0-0	0000 -0-0
87h	TRISC	TRISC7	TRISC6	TRISC5	TRISC4	TRISC3	TRISC2	TRISC1	TRISC0	1111 1111	1111 1111
0Eh	TMR1L	Holding Register for the Least Significant Byte of the 16-bit TMR1 Register								xxxx xxxx	uuuu uuuu
0Fh	TMR1H	Holding Register for the Most Significant Byte of the 16-bit TMR1 Register								xxxx xxxx	uuuu uuuu
10h	T1CON	T1GINV	T1GE	T1CKPS1	T1CKPS0	T1OSCEN	T1SYN \bar{C}	TMR1CS	TMR1ON	0000 0000	uuuu uuuu
15h	CCPR1L	Capture/Compare/PWM Register1 (LSB)								xxxx xxxx	uuuu uuuu
16h	CCPR1H	Capture/Compare/PWM Register1 (MSB)								xxxx xxxx	uuuu uuuu
17h	CCP1CON	—	—	CCP1X	CCP1Y	CCP1M3	CCP1M2	CCP1M1	CCP1M0	--00 0000	--00 0000
1Bh	CCPR2L	Capture/Compare/PWM Register 2 (LSB)								xxxx xxxx	uuuu uuuu
1Ch	CCPR2H	Capture/Compare/PWM Register 2 (MSB)								xxxx xxxx	uuuu uuuu
1Dh	CCP2CON	—	—	CCP2X	CCP2Y	CCP2M3	CCP2M2	CCP2M1	CCP2M0	--00 0000	--00 0000

Legend: x = unknown, u = unchanged, - = unimplemented, read as '0'. Shaded cells are not used by Capture and Timer1.

PIC16F917/916/914/913

TABLE 15-3: REGISTERS ASSOCIATED WITH PWM AND TIMER2

Address	Name	Bit 7	Bit 6	Bit 5	Bit 4	Bit 3	Bit 2	Bit 1	Bit 0	Value on: POR, BOR	Value on all other Resets
0Bh,8Bh, 10Bh, 18Bh	INTCON	GIE	PEIE	TOIE	INTE	RBIE	T0IF	INTF	RBF	0000 000x	0000 000x
0Ch	PIR1	EEIF	ADIF	RCIF	TXIF	SSPIF	CCP1IF	TMR2IF	TMR1IF	0000 0000	0000 0000
0Dh	PIR2	OSFIF	C2IF	C1IF	LCDIF	—	LVDIF	—	CCP2IF	0000 -0-0	0000 -0-0
8Ch	PIE1	EEIE	ADIE	RCIE	TXIE	SSPIE	CCP1IE	TMR2IE	TMR1IE	0000 0000	0000 0000
8Dh	PIE2	OSFIE	C2IE	C1IE	LCDIE	—	LVDIE	—	CCP2IE	0000 -0-0	0000 -0-0
87h	TRISC	PORTC Data Direction Register								1111 1111	1111 1111
11h	TMR2	Timer2 Module Register								0000 0000	0000 0000
92h	PR2	Timer2 Module Period Register								1111 1111	1111 1111
12h	T2CON	—	TOUTPS3	TOUTPS2	TOUTPS1	TOUTPS0	TMR2ON	T2CKPS1	T2CKPS0	-000 0000	-000 0000
15h	CCPR1L	Capture/Compare/PWM Register 1 (LSB)								xxxx xxxx	uuuu uuuu
16h	CCPR1H	Capture/Compare/PWM Register 1 (MSB)								xxxx xxxx	uuuu uuuu
17h	CCP1CON	—	—	CCP1X	CCP1Y	CCP1M3	CCP1M2	CCP1M1	CCP1M0	--00 0000	--00 0000
1Bh	CCPR2L	Capture/Compare/PWM Register 2 (LSB)								xxxx xxxx	uuuu uuuu
1Ch	CCPR2H	Capture/Compare/PWM Register 2 (MSB)								xxxx xxxx	uuuu uuuu
1Dh	CCP2CON	—	—	CCP2X	CCP2Y	CCP2M3	CCP2M2	CCP2M1	CCP2M0	--00 0000	--00 0000

Legend: x = unknown, u = unchanged, - = unimplemented, read as '0'. Shaded cells are not used by PWM and Timer2.

PIC16F917/916/914/913

NOTES:

16.0 SPECIAL FEATURES OF THE CPU

The PIC16F917/916/914/913 has a host of features intended to maximize system reliability, minimize cost through elimination of external components, provide power saving features and offer code protection.

These features are:

- Reset
 - Power-on Reset (POR)
 - Power-up Timer (PWRT)
 - Oscillator Start-up Timer (OST)
 - Brown-out Reset (BOR)
- Interrupts
- Watchdog Timer (WDT)
- Oscillator Selection
- Sleep
- Code Protection
- ID Locations
- In-Circuit Serial Programming™

The PIC16F917/916/914/913 has two timers that offer necessary delays on power-up. One is the Oscillator Start-up Timer (OST), intended to keep the chip in Reset until the crystal oscillator is stable. The other is the Power-up Timer (PWRT), which provides a fixed delay of 64 ms (nominal) on power-up only, designed to keep the part in Reset while the power supply stabilizes. There is also circuitry to reset the device if a brown-out occurs, which can use the Power-up Timer to provide at least a 64 ms Reset. With these three functions-on-chip, most applications need no external Reset circuitry.

The Sleep mode is designed to offer a very low-current Power-down mode. The user can wake-up from Sleep through:

- External Reset
- Watchdog Timer Wake-up
- An interrupt

Several oscillator options are also made available to allow the part to fit the application. The INTOSC option saves system cost, while the LP crystal option saves power. A set of configuration bits are used to select various options (see Register 16-1).

PIC16F917/916/914/913

16.1 Configuration Bits

The configuration bits can be programmed (read as '0'), or left unprogrammed (read as '1') to select various device configurations as shown in Register 16-1. These bits are mapped in program memory location 2007h.

Note: Address 2007h is beyond the user program memory space. It belongs to the special configuration memory space (2000h-3FFFh), which can be accessed only during programming. See "PIC16F917/916/914/913 Memory Programming Specification" (DS41244) for more information.

REGISTER 16-1: CONFIG – CONFIGURATION WORD (ADDRESS: 2007h)

	$\overline{\text{DEBUG}}$	FCMEN	IESO	BOREN1	BOREN0	$\overline{\text{CPD}}$	$\overline{\text{CP}}$	MCLRE	$\overline{\text{PWRTE}}$	WDTE	FOSC2	FOSC1	FOSC0
bit 13													bit 0
bit 13	Unimplemented: Read as '1'												
bit 12	DEBUG: In-Circuit Debugger Mode bit 1 = In-Circuit Debugger disabled, RB6/ICSPCLK/ICDCK/SEG14 and RB7/ICSPDAT/ICDDAT/SEG13 are general purpose I/O pins 0 = In-Circuit Debugger enabled, RB6/ICSPCLK/ICDCK/SEG14 and RB7/ICSPDAT/ICDDAT/SEG13 are dedicated to the debugger												
bit 11	FCMEN: Fail-Safe Clock Monitor Enabled bit 1 = Fail-Safe Clock Monitor is enabled 0 = Fail-Safe Clock Monitor is disabled												
bit 10	IESO: Internal External Switchover bit 1 = Internal External Switchover mode is enabled 0 = Internal External Switchover mode is disabled												
bit 9-8	BOREN<1:0>: Brown-out Reset Selection bits ⁽¹⁾ 11 = BOR enabled 10 = BOR enabled during operation and disabled in Sleep 01 = BOR controlled by SBOREN bit (PCON<4>) 00 = BOR disabled												
bit 7	CPD: Data Code Protection bit ⁽²⁾ 1 = Data memory code protection is disabled 0 = Data memory code protection is enabled												
bit 6	CP: Code Protection bit ⁽³⁾ 1 = Program memory code protection is disabled 0 = Program memory code protection is enabled												
bit 5	MCLRE: RB3/MCLR/VPP pin function select bit ⁽⁴⁾ 1 = RB3/MCLR/VPP pin function is MCLR 0 = RB3/MCLR/VPP pin function is digital input, MCLR internally tied to VDD												
bit 4	PWRTE: Power-up Timer Enable bit 1 = PWRT disabled 0 = PWRT enabled												
bit 3	WDTE: Watchdog Timer Enable bit 1 = WDT enabled 0 = WDT disabled and can be enabled by SWDTEN bit (WDTCON<0>)												
bit 2-0	FOSC<2:0>: Oscillator Selection bits 111 = RC oscillator: CLKO function on RA6/OSC2/CLKO/T1OSO pin, RC on RA7/OSC1/CLKI/T1OSI 110 = RCIO oscillator: I/O function on RA6/OSC2/CLKO/T1OSO pin, RC on RA7/OSC1/CLKI/T1OSI 101 = INTOSC oscillator: CLKO function on RA6/OSC2/CLKO/T1OSO pin, I/O function on RA7/OSC1/CLKI/T1OSI 100 = INTOSCIO oscillator: I/O function on RA6/OSC2/CLKO/T1OSO pin, I/O function on RA7/OSC1/CLKI/T1OSI 011 = EC: I/O function on RA6/OSC2/CLKO/T1OSO pin, CLKI on RA7/OSC1/CLKI/T1OSI 010 = HS oscillator: High-speed crystal/resonator on RA6/OSC2/CLKO/T1OSO and RA7/OSC1/CLKI/T1OSI 001 = XT oscillator: Crystal/resonator on RA6/OSC2/CLKO/T1OSO and RA7/OSC1/CLKI/T1OSI 000 = LP oscillator: Low-power crystal on RA6/OSC2/CLKO/T1OSO and RA7/OSC1/CLKI/T1OSI												

- Note**
- 1: Enabling Brown-out Reset does not automatically enable Power-up Timer.
 - 2: The entire data EEPROM will be erased when the code protection is turned off.
 - 3: The entire program memory will be erased when the code protection is turned off.
 - 4: When MCLR is asserted in INTOSC or RC mode, the internal clock oscillator is disabled.

Legend:

R = Readable bit	W = Writable bit	U = Unimplemented bit, read as '0'
- n = Value at POR	'1' = Bit is set	'0' = Bit is cleared
		x = Bit is unknown

16.2 Reset

The PIC16F917/916/914/913 differentiates between various kinds of Reset:

- Power-on Reset (POR)
- WDT Reset during normal operation
- WDT Reset during Sleep
- $\overline{\text{MCLR}}$ Reset during normal operation
- $\overline{\text{MCLR}}$ Reset during Sleep
- Brown-out Reset (BOR)

Some registers are not affected in any Reset condition; their status is unknown on POR and unchanged in any other Reset. Most other registers are reset to a "Reset state" on:

- Power-on Reset
- $\overline{\text{MCLR}}$ Reset
- $\overline{\text{MCLR}}$ Reset during Sleep
- WDT Reset
- Brown-out Reset (BOR)

They are not affected by a WDT wake-up since this is viewed as the resumption of normal operation. $\overline{\text{TO}}$ and $\overline{\text{PD}}$ bits are set or cleared differently in different Reset situations, as indicated in Table 16-2. These bits are used in software to determine the nature of the Reset. See Table 16-5 for a full description of Reset states of all registers.

A simplified block diagram of the On-Chip Reset Circuit is shown in Figure 16-1.

The $\overline{\text{MCLR}}$ Reset path has a noise filter to detect and ignore small pulses. See **Section 19.0 "Electrical Specifications"** for pulse width specifications.

FIGURE 16-1: SIMPLIFIED BLOCK DIAGRAM OF ON-CHIP RESET CIRCUIT

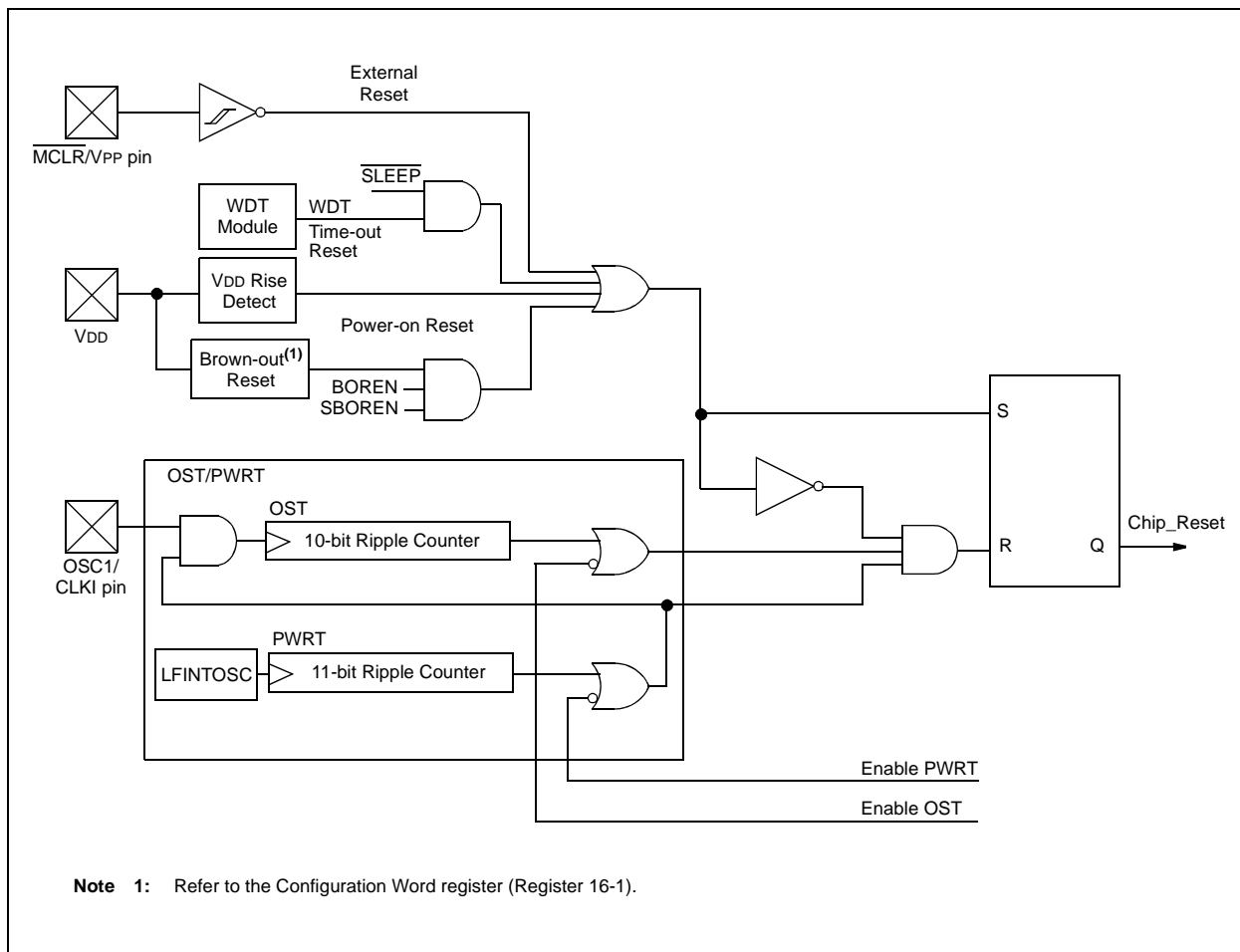

PIC16F917/916/914/913

16.3 Power-on Reset

The on-chip POR circuit holds the chip in Reset until VDD has reached a high enough level for proper operation. To take advantage of the POR, simply connect the MCLR pin through a resistor to VDD. This will eliminate external RC components usually needed to create Power-on Reset. A maximum rise time for VDD is required. See **Section 19.0 “Electrical Specifications”** for details. If the BOR is enabled, the maximum rise time specification does not apply. The BOR circuitry will keep the device in Reset until VDD reaches VBOR (see **Section 16.3.3 “Brown-Out Reset (BOR)”**).

Note: The POR circuit does not produce an internal Reset when VDD declines. To re-enable the POR, VDD must reach VSS for a minimum of 100 μ s.

When the device starts normal operation (exits the Reset condition), device operating parameters (i.e., voltage, frequency, temperature, etc.) must be met to ensure operation. If these conditions are not met, the device must be held in Reset until the operating conditions are met.

For additional information, refer to Application Note AN607, “Power-up Trouble Shooting” (DS00607).

16.3.1 MCLR

PIC16F917/916/914/913 has a noise filter in the MCLR Reset path. The filter will detect and ignore small pulses.

It should be noted that a WDT Reset does not drive MCLR pin low.

The behavior of the ESD protection on the MCLR pin has been altered from early devices of this family. Voltages applied to the pin that exceed its specification can result in both MCLR Resets and excessive current beyond the device specification during the ESD event. For this reason, Microchip recommends that the MCLR pin no longer be tied directly to VDD. The use of an RC network, as shown in Figure 16-2, is suggested.

An internal MCLR option is enabled by clearing the MCLRE bit in the Configuration Word register. When cleared, MCLR is internally tied to VDD and an internal weak pull-up is enabled for the MCLR pin. In-Circuit Serial Programming is not affected by selecting the internal MCLR option.

FIGURE 16-2: RECOMMENDED MCLR CIRCUIT

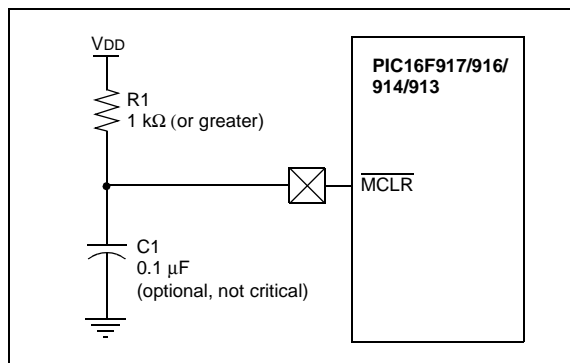

16.3.2 POWER-UP TIMER (PWRT)

The Power-up Timer provides a fixed 64 ms (nominal) time-out on power-up only, from POR or Brown-out Reset. The Power-up Timer operates from the 31 kHz LFINTOSC oscillator. For more information, see **Section 4.4 “Internal Clock Modes”**. The chip is kept in Reset as long as PWRT is active. The PWRT delay allows the VDD to rise to an acceptable level. A configuration bit, PWRTÉ, can disable (if set) or enable (if cleared or programmed) the Power-up Timer. The Power-up Timer should be enabled when Brown-out Reset is enabled, although it is not required.

The Power-up Timer delay will vary from chip-to-chip and vary due to:

- VDD variation
- Temperature variation
- Process variation

See DC parameters for details (**Section 19.0 “Electrical Specifications”**).

16.3.3 BROWN-OUT RESET (BOR)

The BOREN0 and BOREN1 bits in the Configuration Word register selects one of four BOR modes. Two modes have been added to allow software or hardware control of the BOR enable. When BOREN<1:0> = 01, the SBOREN bit (PCON<4>) enables/disables the BOR allowing it to be controlled in software. By selecting BOREN<1:0>, the BOR is automatically disabled in Sleep to conserve power and enabled on wake-up. In this mode, the SBOREN bit is disabled. See Register 16-1 for the configuration word definition.

If VDD falls below VBOR for greater than parameter (TBOR) (see **Section 19.0 “Electrical Specifications”**), the Brown-out situation will reset the device. This will occur regardless of VDD slew rate. A Reset is not insured to occur if VDD falls below VBOR for less than parameter (TBOR).

On any Reset (Power-on, Brown-out Reset, Watchdog Timer, etc.), the chip will remain in Reset until VDD rises above VBOR (see Figure 16-3). The Power-up Timer will now be invoked, if enabled and will keep the chip in Reset an additional 64 ms.

Note: The Power-up Timer is enabled by the PWRTÉ bit in the Configuration Word.

If VDD drops below VBOR while the Power-up Timer is running, the chip will go back into a Brown-out Reset and the Power-up Timer will be re-initialized. Once VDD rises above VBOR, the Power-up Timer will execute a 64 ms Reset.

16.3.4 BOR CALIBRATION

The PIC16F917/916/914/913 stores the BOR calibration values in fuses located in the Calibration Word (2008h). The Calibration Word is not erased when using the specified bulk erase sequence in the “PIC16F917/916/914/913 Memory Programming Specification” (DS41244) and thus, does not require reprogramming.

Address 2008h is beyond the user program memory space. It belongs to the special configuration memory space (2000h-3FFFh), which can be accessed only during programming. See “PIC16F917/916/914/913 Memory Programming Specification” (DS41244) for more information.

FIGURE 16-3: BROWN-OUT SITUATIONS

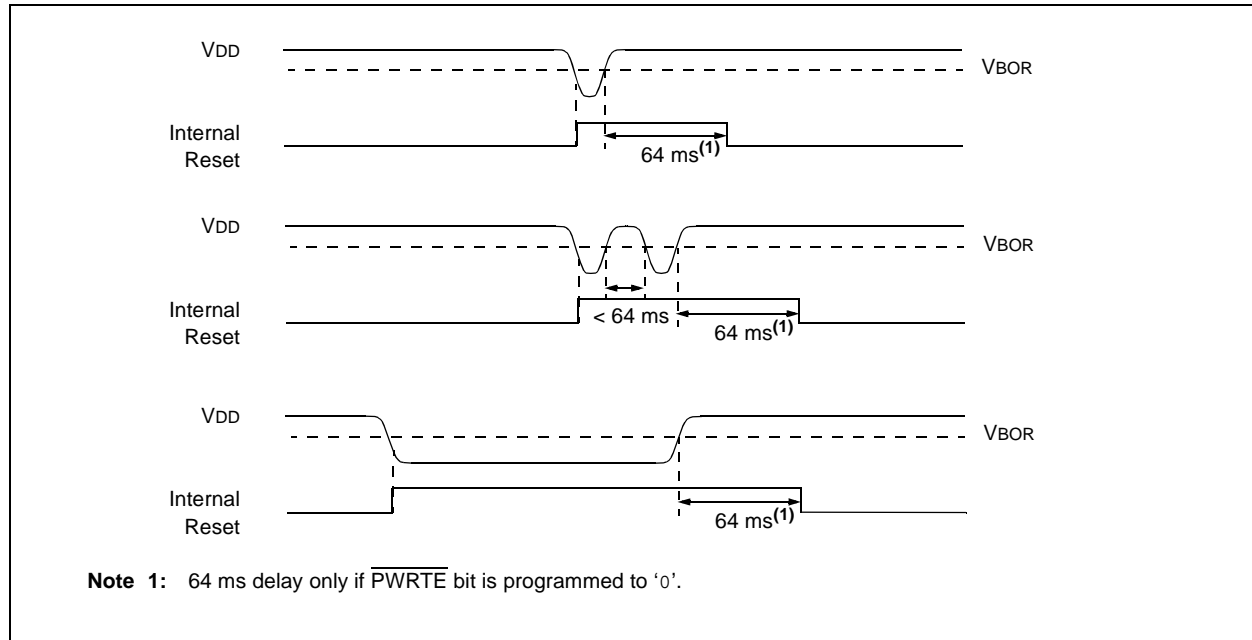

PIC16F917/916/914/913

16.3.5 TIME-OUT SEQUENCE

On power-up, the time-out sequence is as follows: first, PWRT time-out is invoked after POR has expired, then OST is activated after the PWRT time-out has expired. The total time-out will vary based on oscillator configuration and $\overline{\text{PWRTE}}$ bit status. For example, in EC mode with $\overline{\text{PWRTE}}$ bit erased (PWRT disabled), there will be no time-out at all. Figure 16-4, Figure 16-5 and Figure 16-6 depict time-out sequences. The device can execute code from the INTOSC while OST is active, by enabling Two-Speed Start-up or Fail-Safe Monitor (see Section 4.6.2 “Two-Speed Start-up Sequence” and Section 4.7 “Fail-Safe Clock Monitor”).

Since the time-outs occur from the POR pulse, if $\overline{\text{MCLR}}$ is kept low long enough, the time-outs will expire. Then, bringing $\overline{\text{MCLR}}$ high will begin execution immediately (see Figure 16-5). This is useful for testing purposes or to synchronize more than one PIC16F917/916/914/913 device operating in parallel.

Table 16-5 shows the Reset conditions for some special registers, while Table 16-5 shows the Reset conditions for all the registers.

16.3.6 POWER CONTROL (PCON) REGISTER

The Power Control (PCON) register (address 8Eh) has two Status bits to indicate what type of Reset that last occurred.

Bit 0 is $\overline{\text{BOR}}$ (Brown-out Reset). $\overline{\text{BOR}}$ is unknown on Power-on Reset. It must then be set by the user and checked on subsequent Resets to see if $\text{BOR} = 0$, indicating that a Brown-out has occurred. The $\overline{\text{BOR}}$ Status bit is a “don’t care” and is not necessarily predictable if the brown-out circuit is disabled ($\text{BOREN} < 1:0 > = 00$ in the Configuration Word register).

Bit 1 is $\overline{\text{POR}}$ (Power-on Reset). It is a ‘0’ on Power-on Reset and unaffected otherwise. The user must write a ‘1’ to this bit following a Power-on Reset. On a subsequent Reset, if $\overline{\text{POR}}$ is ‘0’, it will indicate that a Power-on Reset has occurred (i.e., VDD may have gone too low).

For more information, see Section 16.3.3 “Brown-Out Reset (BOR)”.

TABLE 16-1: TIME-OUT IN VARIOUS SITUATIONS

Oscillator Configuration	Power-up		Brown-out Reset		Wake-up from Sleep
	$\overline{\text{PWRTE}} = 0$	$\overline{\text{PWRTE}} = 1$	$\overline{\text{PWRTE}} = 0$	$\overline{\text{PWRTE}} = 1$	
XT, HS, LP ⁽¹⁾	TPWRT + 1024 • TOSC	1024 • TOSC	TPWRT + 1024 • TOSC	1024 • TOSC	1024 • TOSC
RC, EC, INTOSC	TPWRT	—	TPWRT	—	—

Note 1: LP mode with T1OSC disabled.

TABLE 16-2: PCON BITS AND THEIR SIGNIFICANCE

$\overline{\text{POR}}$	$\overline{\text{BOR}}$	$\overline{\text{TO}}$	$\overline{\text{PD}}$	Condition
0	u	1	1	Power-on Reset
1	0	1	1	Brown-out Reset
u	u	0	u	WDT Reset
u	u	0	0	WDT Wake-up
u	u	u	u	$\overline{\text{MCLR}}$ Reset during normal operation
u	u	1	0	$\overline{\text{MCLR}}$ Reset during Sleep

Legend: u = unchanged, x = unknown

TABLE 16-3: SUMMARY OF REGISTERS ASSOCIATED WITH BROWN-OUT

Address	Name	Bit 7	Bit 6	Bit 5	Bit 4	Bit 3	Bit 2	Bit 1	Bit 0	Value on POR, BOR	Value on all other Resets ⁽¹⁾
03h	STATUS	IRP	RP1	RPO	$\overline{\text{TO}}$	$\overline{\text{PD}}$	Z	DC	C	0001 1xxx	000q quuu
8Eh	PCON	—	—	—	SBOREN	—	—	$\overline{\text{POR}}$	$\overline{\text{BOR}}$	--01 --qq	--0u --uu

Legend: u = unchanged, x = unknown, - = unimplemented bit, reads as ‘0’, q = value depends on condition. Shaded cells are not used by BOR.

Note 1: Other (non Power-up) Resets include $\overline{\text{MCLR}}$ Reset and Watchdog Timer Reset during normal operation.

FIGURE 16-4: TIME-OUT SEQUENCE ON POWER-UP (DELAYED $\overline{\text{MCLR}}$): CASE 1

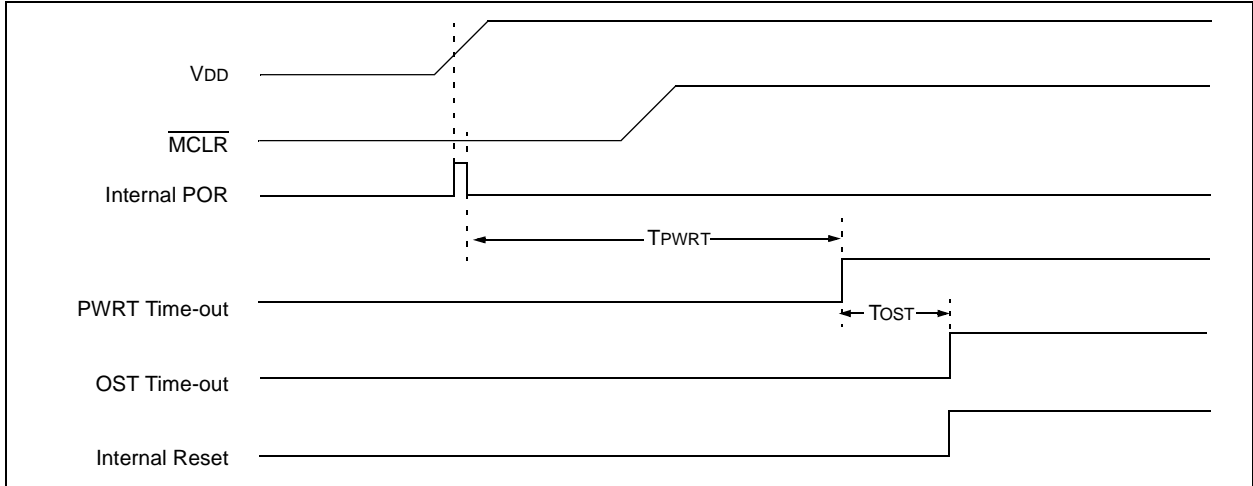

FIGURE 16-5: TIME-OUT SEQUENCE ON POWER-UP (DELAYED $\overline{\text{MCLR}}$): CASE 2

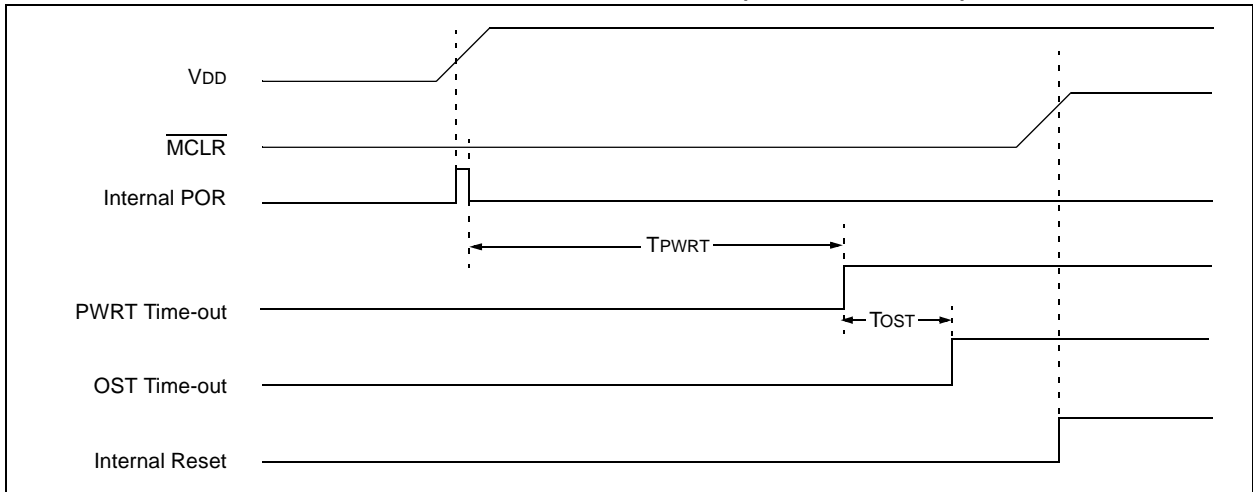
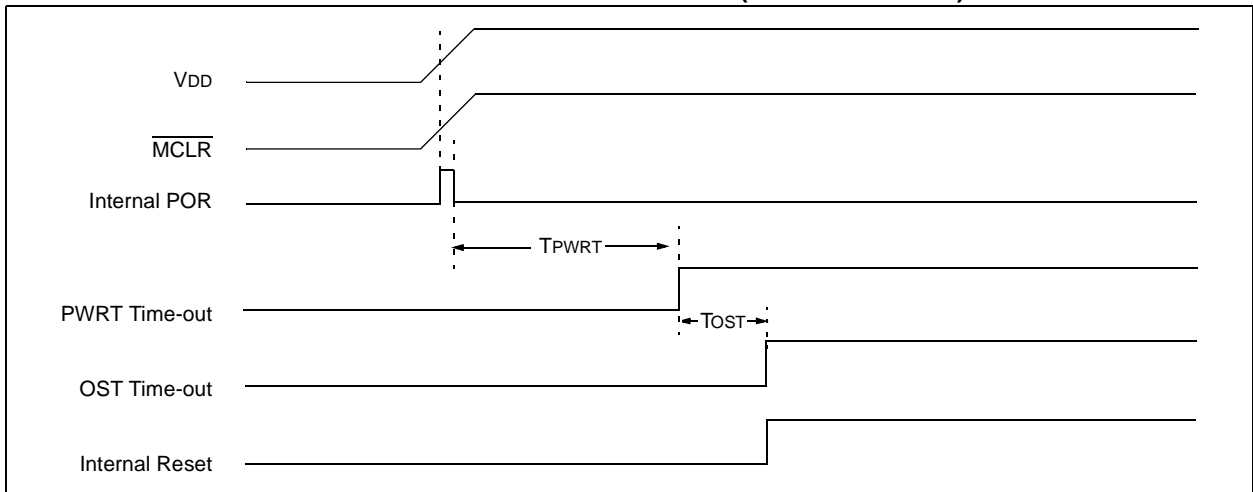

FIGURE 16-6: TIME-OUT SEQUENCE ON POWER-UP ($\overline{\text{MCLR}}$ WITH V_{DD}): CASE 3



PIC16F917/916/914/913

TABLE 16-4: INITIALIZATION CONDITION FOR REGISTERS

Register	Address	Power-on Reset	<ul style="list-style-type: none"> • MCLR Reset • WDT Reset • Brown-out Reset⁽¹⁾ 	<ul style="list-style-type: none"> • Wake-up from Sleep through interrupt • Wake-up from Sleep through WDT time-out
W	—	xxxx xxxx	uuuu uuuu	uuuu uuuu
INDF	00h/80h/ 100h/180h	xxxx xxxx	xxxx xxxx	uuuu uuuu
TMR0	01h/101h	xxxx xxxx	uuuu uuuu	uuuu uuuu
PCL	02h/82h/ 102h/182h	0000 0000	0000 0000	PC + 1 ⁽³⁾
STATUS	03h/83h/ 103h/183h	0001 1xxx	000q quuu ⁽⁴⁾	uuuq quuu ⁽⁴⁾
FSR	04h/84h/ 104h/184h	xxxx xxxx	uuuu uuuu	uuuu uuuu
PORTA	05h	xxxx xxxx	0000 0000	uuuu uuuu
PORTB	06h/106h	xxxx xxxx	0000 0000	uuuu uuuu
PORTC	07h	xxxx xxxx	0000 0000	uuuu uuuu
PORTD	08h	xxxx xxxx	0000 0000	uuuu uuuu
PORTE	09h	---- xxxx	---- 0000	---- uuuu
PCLATH	0Ah/8Ah/ 10Ah/18Ah	---0 0000	---0 0000	---u uuuu
INTCON	0Bh/8Bh/ 10Bh/18Bh	0000 000x	0000 000x	uuuu uuuu ⁽²⁾
PIR1	0Ch	0000 0000	0000 0000	uuuu uuuu ⁽²⁾
PIR2	0Dh	0000 -0-0	0000 -0-0	uuuu -u-u
TMR1L	0Eh	xxxx xxxx	uuuu uuuu	uuuu uuuu
TMR1H	0Fh	xxxx xxxx	uuuu uuuu	uuuu uuuu
T1CON	10h	0000 0000	uuuu uuuu	uuuu uuuu
TMR2	11h	01-0 0-00	01-0 0-00	uu-u u-uu
T2CON	12h	-000 0000	-000 0000	-uuu uuuu
SSPBUF	13h	xxxx xxxx	xxxx xxxx	uuuu uuuu
SSPCON	14h	0000 0000	0000 0000	uuuu uuuu
CCPR1L	15h	0000 0000	0000 0000	uuuu uuuu
CCPR1H	16h	0000 0010	0000 0010	uuuu uuuu
CCP1CON	17h	000x 000x	000x 000x	uuuu uuuu
RCSTA	18h	---0 1000	---0 1000	---u uuuu
TXREG	19h	0000 0000	0000 0000	uuuu uuuu
RCREG	1Ah	0000 0000	0000 0000	uuuu uuuu
CCP2CON	1Dh	--00 0000	--00 0000	--uu uuuu
ADRESH	1Eh	xxxx xxxx	uuuu uuuu	uuuu uuuu

Legend: u = unchanged, x = unknown, - = unimplemented bit, reads as '0', q = value depends on condition.

Note 1: If VDD goes too low, Power-on Reset will be activated and registers will be affected differently.

2: One or more bits in INTCON and/or PIR1 will be affected (to cause wake-up).

3: When the wake-up is due to an interrupt and the GIE bit is set, the PC is loaded with the interrupt vector (0004h).

4: See Table 16-5 for Reset value for specific condition.

5: If Reset was due to brown-out, then bit 0 = 0. All other Resets will cause bit 0 = u.

PIC16F917/916/914/913

TABLE 16-4: INITIALIZATION CONDITION FOR REGISTERS (CONTINUED)

Register	Address	Power-on Reset	<ul style="list-style-type: none"> • MCLR Reset • WDT Reset • Brown-out Reset⁽¹⁾ 	<ul style="list-style-type: none"> • Wake-up from Sleep through interrupt • Wake-up from Sleep through WDT time-out
ADCON0	1Fh	0000 0000	0000 0000	uuuu uuuu
OPTION_REG	81h/181h	1111 1111	1111 1111	uuuu uuuu
TRISA	85h	1111 1111	1111 1111	uuuu uuuu
TRISB	86h/186h	1111 1111	1111 1111	uuuu uuuu
TRISC	87h	1111 1111	1111 1111	uuuu uuuu
TRISD	88h	1111 1111	1111 1111	uuuu uuuu
TRISE	89h	1111 1111	1111 1111	uuuu uuuu
PIE1	8Ch	0000 0000	0000 0000	uuuu uuuu
PIE2	8Dh	0000 0000	0000 0000	uuuu uuuu
PCON	8Eh	--01 --0x	--0u --uu ^(1,5)	--uu --uu
OSCCON	8Fh	-110 q000	-110 x000	-uuu uuuu
OSCTUNE	90h	---0 0000	---u uuuu	---u uuuu
ANSEL	91h	1111 1111	1111 1111	uuuu uuuu
PR2	92h	1111 1111	1111 1111	1111 1111
SSPADD	93h	0000 0000	0000 0000	uuuu uuuu
SSPSTAT	94h	0000 0000	0000 0000	uuuu uuuu
WPUB	95h	1111 1111	1111 1111	uuuu uuuu
IOCB	96h	0000 ----	0000 ----	uuuu ----
CMCON1	97h	---- --10	---- --10	---- --uu
TXSTA	98h	0000 -010	0000 -010	uuuu -uuu
SPBRG	99h	0000 0000	0000 0000	uuuu uuuu
CMCON0	9Ch	0000 0000	0000 0000	uuuu uuuu
VRCON	9Dh	0-0- 0000	0-0- 0000	u-u- uuuu
ADRESL	9Eh	xxxx xxxx	uuuu uuuu	uuuu uuuu
ADCON1	9Fh	-000 ----	-000 ----	-uuu ----
WDTCON	105h	---0 1000	---0 1000	---u uuuu
LCDCON	107h	0001 0011	0001 0011	uuuu uuuu
LCDPS	108h	0000 0000	0000 0000	uuuu uuuu
LVDCON	109h	--00 -100	--00 -100	--uu -uuu
EEDATL	10Ch	0000 0000	0000 0000	uuuu uuuu
EEADRL	10Dh	0000 0000	0000 0000	uuuu uuuu
EEDATH	10Eh	--00 0000	0000 0000	uuuu uuuu
EEADRH	10Fh	---0 0000	0000 0000	uuuu uuuu
LCDDATA0	110h	xxxx xxxx	uuuu uuuu	uuuu uuuu
LCDDATA1	111h	xxxx xxxx	uuuu uuuu	uuuu uuuu
LCDDATA2	112h	xxxx xxxx	uuuu uuuu	uuuu uuuu

Legend: u = unchanged, x = unknown, - = unimplemented bit, reads as '0', q = value depends on condition.

- Note 1:** If VDD goes too low, Power-on Reset will be activated and registers will be affected differently.
- 2:** One or more bits in INTCON and/or PIR1 will be affected (to cause wake-up).
- 3:** When the wake-up is due to an interrupt and the GIE bit is set, the PC is loaded with the interrupt vector (0004h).
- 4:** See Table 16-5 for Reset value for specific condition.
- 5:** If Reset was due to brown-out, then bit 0 = 0. All other Resets will cause bit 0 = u.

PIC16F917/916/914/913

TABLE 16-4: INITIALIZATION CONDITION FOR REGISTERS (CONTINUED)

Register	Address	Power-on Reset	<ul style="list-style-type: none"> • MCLR Reset • WDT Reset • Brown-out Reset⁽¹⁾ 	<ul style="list-style-type: none"> • Wake-up from Sleep through interrupt • Wake-up from Sleep through WDT time-out
LCDDATA3	113h	xxxx xxxx	uuuu uuuu	uuuu uuuu
LCDDATA4	114h	xxxx xxxx	uuuu uuuu	uuuu uuuu
LCDDATA5	115h	xxxx xxxx	uuuu uuuu	uuuu uuuu
LCDDATA6	116h	xxxx xxxx	uuuu uuuu	uuuu uuuu
LCDDATA7	117h	xxxx xxxx	uuuu uuuu	uuuu uuuu
LCDDATA8	118h	xxxx xxxx	uuuu uuuu	uuuu uuuu
LCDDATA9	119h	xxxx xxxx	uuuu uuuu	uuuu uuuu
LCDDATA10	11Ah	xxxx xxxx	uuuu uuuu	uuuu uuuu
LCDDATA11	11Bh	xxxx xxxx	uuuu uuuu	uuuu uuuu
LCDSE0	11Ch	0000 0000	uuuu uuuu	uuuu uuuu
LCDSE1	11Dh	0000 0000	uuuu uuuu	uuuu uuuu
LCDSE2	11Eh	0000 0000	uuuu uuuu	uuuu uuuu
EECON1	18Ch	x--- x000	u--- q000	u--- uuuu

Legend: u = unchanged, x = unknown, - = unimplemented bit, reads as '0', q = value depends on condition.

- Note 1:** If VDD goes too low, Power-on Reset will be activated and registers will be affected differently.
- 2:** One or more bits in INTCON and/or PIR1 will be affected (to cause wake-up).
- 3:** When the wake-up is due to an interrupt and the GIE bit is set, the PC is loaded with the interrupt vector (0004h).
- 4:** See Table 16-5 for Reset value for specific condition.
- 5:** If Reset was due to brown-out, then bit 0 = 0. All other Resets will cause bit 0 = u.

TABLE 16-5: INITIALIZATION CONDITION FOR SPECIAL REGISTERS

Condition	Program Counter	Status Register	PCON Register
Power-on Reset	000h	0001 1xxx	--01 --0x
MCLR Reset during normal operation	000h	000u uuuu	--0u --uu
MCLR Reset during Sleep	000h	0001 0uuu	--0u --uu
WDT Reset	000h	0000 uuuu	--0u --uu
WDT Wake-up	PC + 1	uuu0 0uuu	--uu --uu
Brown-out Reset	000h	0001 1uuu	--01 --10
Interrupt Wake-up from Sleep	PC + 1 ⁽¹⁾	uuu1 0uuu	--uu --uu

Legend: u = unchanged, x = unknown, - = unimplemented bit, reads as '0'.

- Note 1:** When the wake-up is due to an interrupt and Global Interrupt Enable bit, GIE, is set, the PC is loaded with the interrupt vector (0004h) after execution of PC + 1.

16.4 Interrupts

The PIC16F917/916/914/913 has multiple sources of interrupt:

- External Interrupt RB0/INT/SEG0
- TMR0 Overflow Interrupt
- PORTB Change Interrupts
- 2 Comparator Interrupts
- A/D Interrupt
- Timer1 Overflow Interrupt
- EEPROM Data Write Interrupt
- Fail-Safe Clock Monitor Interrupt
- LCD Interrupt
- PLVD Interrupt
- USART Receive and Transmit interrupts
- CCP1 and CCP2 Interrupts
- TMR2 Interrupt

The Interrupt Control (INTCON) register and Peripheral Interrupt Request 1 (PIR1) register record individual interrupt requests in flag bits. The INTCON register also has individual and global interrupt enable bits.

A Global Interrupt Enable bit, GIE (INTCON<7>), enables (if set) all unmasked interrupts, or disables (if cleared) all interrupts. Individual interrupts can be disabled through their corresponding enable bits in the INTCON register and PIE1 register. GIE is cleared on Reset.

The Return from Interrupt instruction, `RETFIE`, exits the interrupt routine, as well as sets the GIE bit, which re-enables unmasked interrupts.

The following interrupt flags are contained in the INTCON register:

- INT Pin Interrupt
- PORTB Change Interrupt
- TMR0 Overflow Interrupt

The peripheral interrupt flags are contained in the special registers, PIR1 and PIR2. The corresponding interrupt enable bit are contained in the special registers, PIE1 and PIE2.

The following interrupt flags are contained in the PIR1 register:

- EEPROM Data Write Interrupt
- A/D Interrupt
- USART Receive and Transmit Interrupts
- Timer1 Overflow Interrupt
- CCP1 Interrupt
- SSP Interrupt

The following interrupt flags are contained in the PIR2 register:

- Fail-Safe Clock Monitor Interrupt
- Comparator 1 and 2 Interrupts
- LCD Interrupt
- PLVD Interrupt
- CCP2 Interrupt

When an interrupt is serviced:

- The GIE is cleared to disable any further interrupt.
- The return address is pushed onto the stack.
- The PC is loaded with 0004h.

For external interrupt events, such as the INT pin or PORTB change interrupt, the interrupt latency will be three or four instruction cycles. The exact latency depends upon when the interrupt event occurs (see Figure 16-8). The latency is the same for one or two-cycle instructions. Once in the Interrupt Service Routine, the source(s) of the interrupt can be determined by polling the interrupt flag bits. The interrupt flag bit(s) must be cleared in software before re-enabling interrupts to avoid multiple interrupt requests.

Note 1: Individual interrupt flag bits are set, regardless of the status of their corresponding mask bit or the GIE bit.

2: When an instruction that clears the GIE bit is executed, any interrupts that were pending for execution in the next cycle are ignored. The interrupts, which were ignored, are still pending to be serviced when the GIE bit is set again.

For additional information on Timer1, A/D or data EEPROM modules, refer to the respective peripheral section.

Note: The ANSEL (91h) and CMCON0 (9Ch) registers must be initialized to configure an analog channel as a digital input. Pins configured as analog inputs will read '0'. Also, if a LCD output function is active on an external interrupt pin, that interrupt function will be disabled.

PIC16F917/916/914/913

16.4.1 RB0/INT/SEG0 INTERRUPT

External interrupt on RB0/INT/SEG0 pin is edge-triggered; either rising if the INTEDG bit (OPTION<6>) is set, or falling, if the INTEDG bit is clear. When a valid edge appears on the RB0/INT/SEG0 pin, the INTF bit (INTCON<1>) is set. This interrupt can be disabled by clearing the INTE control bit (INTCON<4>). The INTF bit must be cleared in software in the Interrupt Service Routine before re-enabling this interrupt. The RB0/INT/SEG0 interrupt can wake-up the processor from Sleep if the INTE bit was set prior to going into Sleep. The status of the GIE bit decides whether or not the processor branches to the interrupt vector following wake-up (0004h). See **Section 16.7 “Power-Down Mode (Sleep)”** for details on Sleep and Figure 16-10 for timing of wake-up from Sleep through RB0/INT/SEG0 interrupt.

16.4.2 TMR0 INTERRUPT

An overflow (FFh → 00h) in the TMR0 register will set the T0IF (INTCON<2>) bit. The interrupt can be enabled/disabled by setting/clearing T0IE (INTCON<5>) bit. See **Section 5.0 “Timer0 Module”** for operation of the Timer0 module.

16.4.3 PORTB INTERRUPT

An input change on PORTB change sets the RBIF (INTCON<0>) bit. The interrupt can be enabled/disabled by setting/clearing the RBIE (INTCON<3>) bit. Plus, individual pins can be configured through the IOCB register.

Note: If a change on the I/O pin should occur when the read operation is being executed (start of the Q2 cycle), then the RBIF interrupt flag may not get set.

FIGURE 16-7: INTERRUPT LOGIC

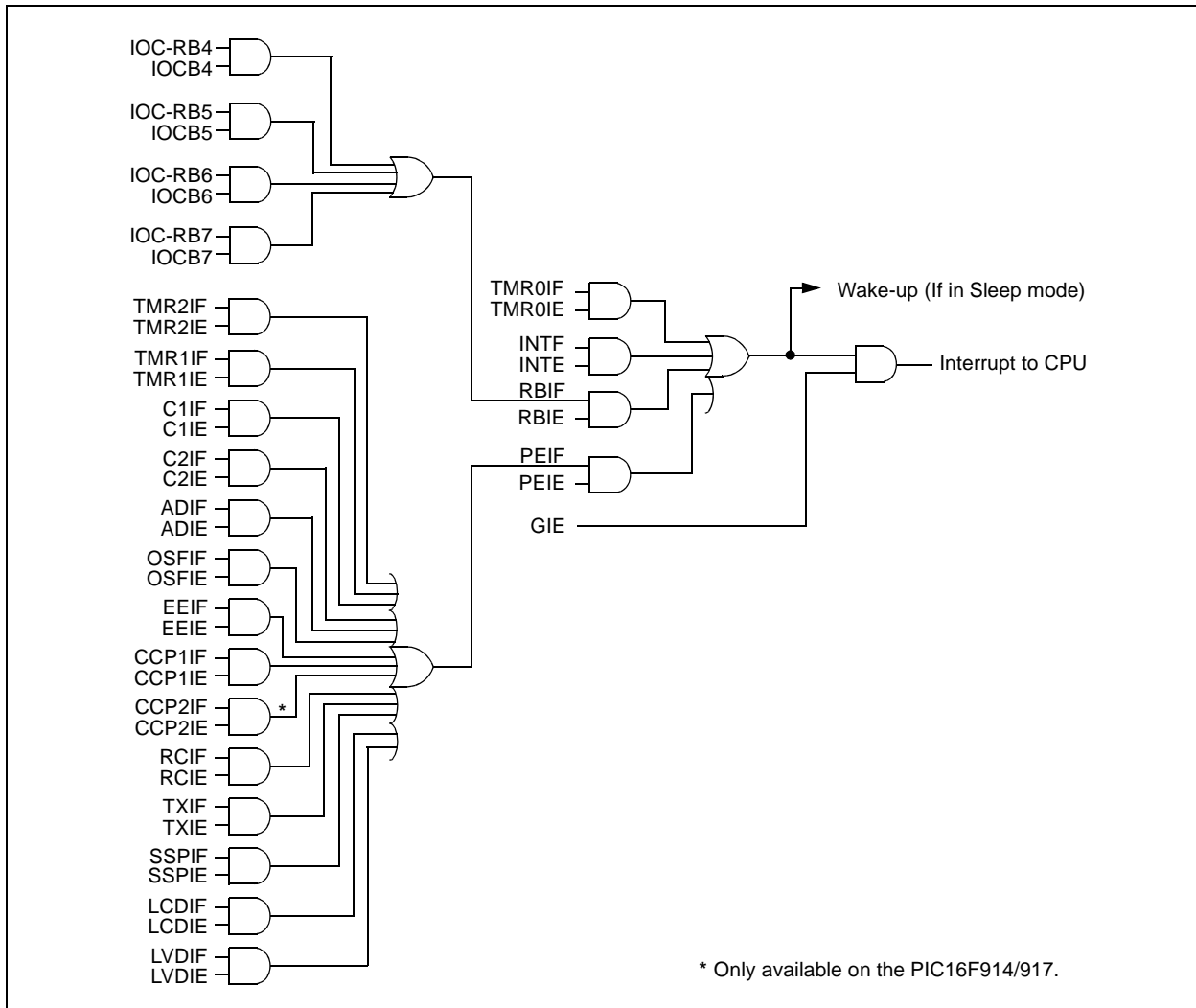

* Only available on the PIC16F914/917.

FIGURE 16-8: INT PIN INTERRUPT TIMING

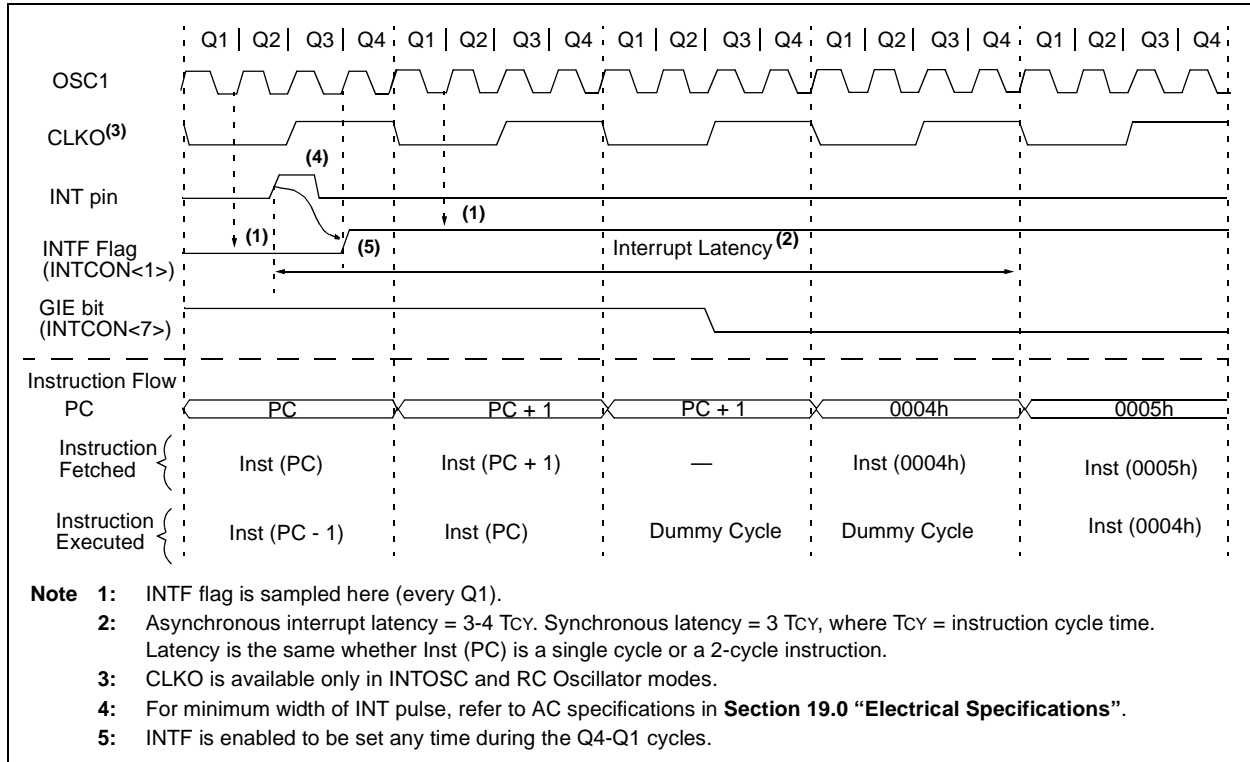

TABLE 16-6: SUMMARY OF INTERRUPT REGISTERS

Addr	Name	Bit 7	Bit 6	Bit 5	Bit 4	Bit 3	Bit 2	Bit 1	Bit 0	Value on POR, BOR	Value on all other Resets
0Bh, 8Bh	INTCON	GIE	PEIE	T0IE	INTE	RBIE	T0IF	INTF	RBIF	0000 000x	0000 000x
0Ch	PIR1	EEIF	ADIF	RCIF	TXIF	SSPIF	CCP1IF	TMR2IF	TMR1IF	0000 0000	0000 0000
0Dh	PIR2	OSFIF	C2IF	C1IF	LCDIF	—	LVDIF	—	CCP2IF	0000 -0-0	0000 -0-0
8Ch	PIE1	EEIE	ADIE	RCIE	TXIE	SSPIE	CCP1IE	TMR2IE	TMR1IE	0000 0000	0000 0000
8Dh	PIE2	OSFIE	C2IE	C1IE	LCDIE	—	LVDIE	—	CCP2IE	0000 -0-0	0000 -0-0

Legend: x = unknown, u = unchanged, - = unimplemented read as '0', q = value depends upon condition.
 Shaded cells are not used by the interrupt module.

PIC16F917/916/914/913

16.5 Context Saving During Interrupts

During an interrupt, only the return PC value is saved on the stack. Typically, users may wish to save key registers during an interrupt (e.g., W and Status registers). This must be implemented in software.

Since the lower 16 bytes of all banks are common in the PIC16F917/916/914/913 (see Figure 2-3), temporary holding registers, W_TEMP and STATUS_TEMP, should be placed in here. These 16 locations do not require banking and therefore, make it easier to context save and restore. The same code shown in Example 16-1 can be used to:

- Store the W register
- Store the Status register
- Execute the ISR code
- Restore the Status (and Bank Select Bit register)
- Restore the W register

Note: The PIC16F917/916/914/913 normally does not require saving the PCLATH. However, if computed GOTO's are used in the ISR and the main code, the PCLATH must be saved and restored in the ISR.

EXAMPLE 16-1: SAVING STATUS AND W REGISTERS IN RAM

```
MOVWF  W_TEMP           ;Copy W to TEMP register
SWAPF  STATUS,W         ;Swap status to be saved into W
CLRF   STATUS           ;bank 0, regardless of current bank, Clears IRP,RP1,RP0
MOVWF  STATUS_TEMP     ;Save status to bank zero STATUS_TEMP register
:
:(ISR)                  ;Insert user code here
:
SWAPF  STATUS_TEMP,W   ;Swap STATUS_TEMP register into W
                        ;(sets bank to original state)
MOVWF  STATUS          ;Move W into Status register
SWAPF  W_TEMP,F        ;Swap W_TEMP
SWAPF  W_TEMP,W        ;Swap W_TEMP into W
```

16.6 Watchdog Timer (WDT)

For PIC16F917/916/914/913, the WDT has been modified from previous PIC16F devices. The new WDT is code and functionally compatible with previous PIC16F WDT modules and adds a 16-bit prescaler to the WDT. This allows the user to have a scaled value for the WDT and TMR0 at the same time. In addition, the WDT time-out value can be extended to 268 seconds. WDT is cleared under certain conditions described in Table 16-7.

16.6.1 WDT OSCILLATOR

The WDT derives its time base from the 31 kHz LFINTOSC. The LTS bit does not reflect that the LFINTOSC is enabled.

The value of WDTCON is '---0 1000' on all Resets. This gives a nominal time base of 16 ms, which is compatible with the time base generated with previous PIC16F microcontroller versions.

Note: When the Oscillator Start-up Timer (OST) is invoked, the WDT is held in Reset, because the WDT Ripple Counter is used by the OST to perform the oscillator delay count. When the OST count has expired, the WDT will begin counting (if enabled).

A new prescaler has been added to the path between the INTOSC and the multiplexers used to select the path for the WDT. This prescaler is 16 bits and can be programmed to divide the INTOSC by 32 to 65536, giving the WDT a nominal range of 1 ms to 268s.

16.6.2 WDT CONTROL

The WDTE bit is located in the Configuration Word register. When set, the WDT runs continuously.

When the WDTE bit in the Configuration Word register is set, the SWDTEN bit (WDTCON<0>) has no effect. If WDTE is clear, then the SWDTEN bit can be used to enable and disable the WDT. Setting the bit will enable it and clearing the bit will disable it.

The PSA and PS<2:0> bits (OPTION_REG) have the same function as in previous versions of the PIC16F family of microcontrollers. See **Section 5.0 "Timer0 Module"** for more information.

FIGURE 16-9: WATCHDOG TIMER BLOCK DIAGRAM

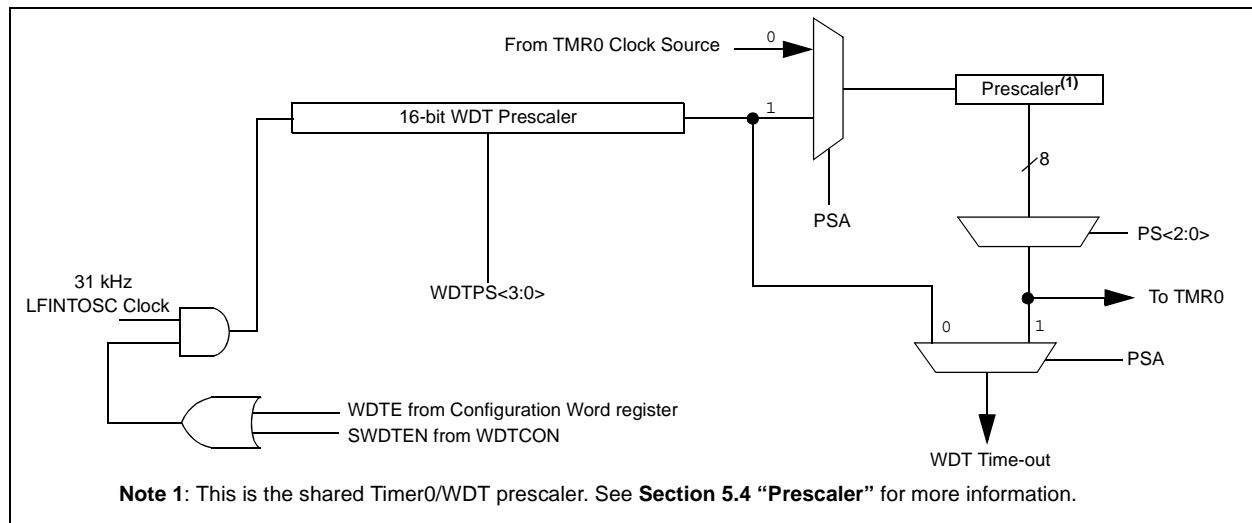

TABLE 16-7: WDT STATUS

Conditions	WDT
WDTE = 0	Cleared
CLRWDT Command	
Oscillator Fail Detected	
Exit Sleep + System Clock = T1OSC, EXTRC, INTOSC, EXTCLK	
Exit Sleep + System Clock = XT, HS, LP	Cleared until the end of OST

PIC16F917/916/914/913

REGISTER 16-2: WDTCON – WATCHDOG TIMER CONTROL REGISTER (ADDRESS: 105h)

U-0	U-0	U-0	R/W-0	R/W-1	R/W-0	R/W-0	R/W-0	
—	—	—	WDTPS3	WDTPS2	WDTPS1	WDTPS0	SWDTEN	
bit 7								bit 0

bit 7-5 **Unimplemented:** Read as '0'

bit 4-1 **WDTPS<3:0>:** Watchdog Timer Period Select bits

Bit Value = Prescale Rate

0000	= 1:32
0001	= 1:64
0010	= 1:128
0011	= 1:256
0100	= 1:512 (Reset value)
0101	= 1:1024
0110	= 1:2048
0111	= 1:4096
1000	= 1:8192
1001	= 1:16384
1010	= 1:32768
1011	= 1:65536
1100	= reserved
1101	= reserved
1110	= reserved
1111	= reserved

bit 0 **SWDTEN:** Software Enable or Disable the Watchdog Timer bit⁽¹⁾

1 = WDT is turned on
0 = WDT is turned off (Reset value)

Note 1: If WDTE configuration bit = 1, then WDT is always enabled, irrespective of this control bit. If WDTE configuration bit = 0, then it is possible to turn WDT on/off with this control bit.

Legend:			
R = Readable bit	W = Writable bit	U = Unimplemented bit, read as '0'	
- n = Value at POR	'1' = Bit is set	'0' = Bit is cleared	x = Bit is unknown

TABLE 16-8: SUMMARY OF WATCHDOG TIMER REGISTERS

Address	Name	Bit 7	Bit 6	Bit 5	Bit 4	Bit 3	Bit 2	Bit 1	Bit 0
105h	WDTCON	—	—	—	WDTPS3	WDTPS2	WSTPS1	WDTPS0	SWDTEN
81h	OPTION_REG	$\overline{\text{RBP}}\text{U}$	INTEDG	T0CS	T0SE	PSA	PS2	PS1	PS0
2007h ⁽¹⁾	CONFIG	$\overline{\text{CPD}}$	$\overline{\text{CP}}$	MCLRE	$\overline{\text{PWRTE}}$	WDTE	FOSC2	FOSC1	FOSC0

Legend: Shaded cells are not used by the Watchdog Timer.

Note 1: See Register 16-1 for operation of all Configuration Word register bits.

16.7 Power-Down Mode (Sleep)

The Power-down mode is entered by executing a `SLEEP` instruction.

If the Watchdog Timer is enabled:

- WDT will be cleared but keeps running.
- \overline{PD} bit in the Status register is cleared.
- \overline{TO} bit is set.
- Oscillator driver is turned off.
- I/O ports maintain the status they had before `SLEEP` was executed (driving high, low or high-impedance).

For lowest current consumption in this mode, all I/O pins should be either at VDD or VSS, with no external circuitry drawing current from the I/O pin, and the comparators and CVREF should be disabled. I/O pins that are high-impedance inputs should be pulled high or low externally to avoid switching currents caused by floating inputs. The T0CKI input should also be at VDD or VSS for lowest current consumption. The contribution from on-chip pull-ups on PORTB should be considered.

The \overline{MCLR} pin must be at a logic high level.

Note: It should be noted that a Reset generated by a WDT time-out does not drive \overline{MCLR} pin low.

16.7.1 WAKE-UP FROM SLEEP

The device can wake-up from Sleep through one of the following events:

1. External Reset input on \overline{MCLR} pin.
2. Watchdog Timer wake-up (if WDT was enabled).
3. Interrupt from RB0/INT/SEG0 pin, PORTB change or a peripheral interrupt.

The first event will cause a device Reset. The two latter events are considered a continuation of program execution. The \overline{TO} and \overline{PD} bits in the Status register can be used to determine the cause of device Reset. The \overline{PD} bit, which is set on power-up, is cleared when Sleep is invoked. \overline{TO} bit is cleared if WDT wake-up occurred.

The following peripheral interrupts can wake the device from Sleep:

1. TMR1 Interrupt. Timer1 must be operating as an asynchronous counter.
2. EUSART Receive Interrupt
3. A/D conversion (when A/D clock source is RC)
4. EEPROM write operation completion
5. Comparator output changes state
6. Interrupt-on-change
7. External Interrupt from INT pin
8. PLVD Interrupt
9. LCD Interrupt (if running during Sleep)

Other peripherals cannot generate interrupts since during Sleep, no on-chip clocks are present.

When the `SLEEP` instruction is being executed, the next instruction (`PC + 1`) is pre-fetched. For the device to wake-up through an interrupt event, the corresponding interrupt enable bit must be set (enabled). Wake-up is regardless of the state of the GIE bit. If the GIE bit is clear (disabled), the device continues execution at the instruction after the `SLEEP` instruction. If the GIE bit is set (enabled), the device executes the instruction after the `SLEEP` instruction, then branches to the interrupt address (0004h). In cases where the execution of the instruction following `SLEEP` is not desirable, the user should have a `NOP` after the `SLEEP` instruction.

Note: If the global interrupts are disabled (GIE is cleared), but any interrupt source has both its interrupt enable bit and the corresponding interrupt flag bits set, the device will immediately wake-up from Sleep. The `SLEEP` instruction is completely executed.

The WDT is cleared when the device wakes up from Sleep, regardless of the source of wake-up.

16.7.2 WAKE-UP USING INTERRUPTS

When global interrupts are disabled (GIE cleared) and any interrupt source has both its interrupt enable bit and interrupt flag bit set, one of the following will occur:

- If the interrupt occurs **before** the execution of a `SLEEP` instruction, the `SLEEP` instruction will complete as a `NOP`. Therefore, the WDT and WDT prescaler and postscaler (if enabled) will not be cleared, the \overline{TO} bit will not be set and the \overline{PD} bit will not be cleared.
- If the interrupt occurs **during or after** the execution of a `SLEEP` instruction, the device will immediately wake-up from Sleep. The `SLEEP` instruction will be completely executed before the wake-up. Therefore, the WDT and WDT prescaler and postscaler (if enabled) will be cleared, the \overline{TO} bit will be set and the \overline{PD} bit will be cleared.

PIC16F917/916/914/913

Even if the flag bits were checked before executing a `SLEEP` instruction, it may be possible for flag bits to become set before the `SLEEP` instruction completes. To determine whether a `SLEEP` instruction executed, test the `PD` bit. If the `PD` bit is set, the `SLEEP` instruction was executed as a `NOP`.

To ensure that the `WDT` is cleared, a `CLRWDT` instruction should be executed before a `SLEEP` instruction.

FIGURE 16-10: WAKE-UP FROM SLEEP THROUGH INTERRUPT

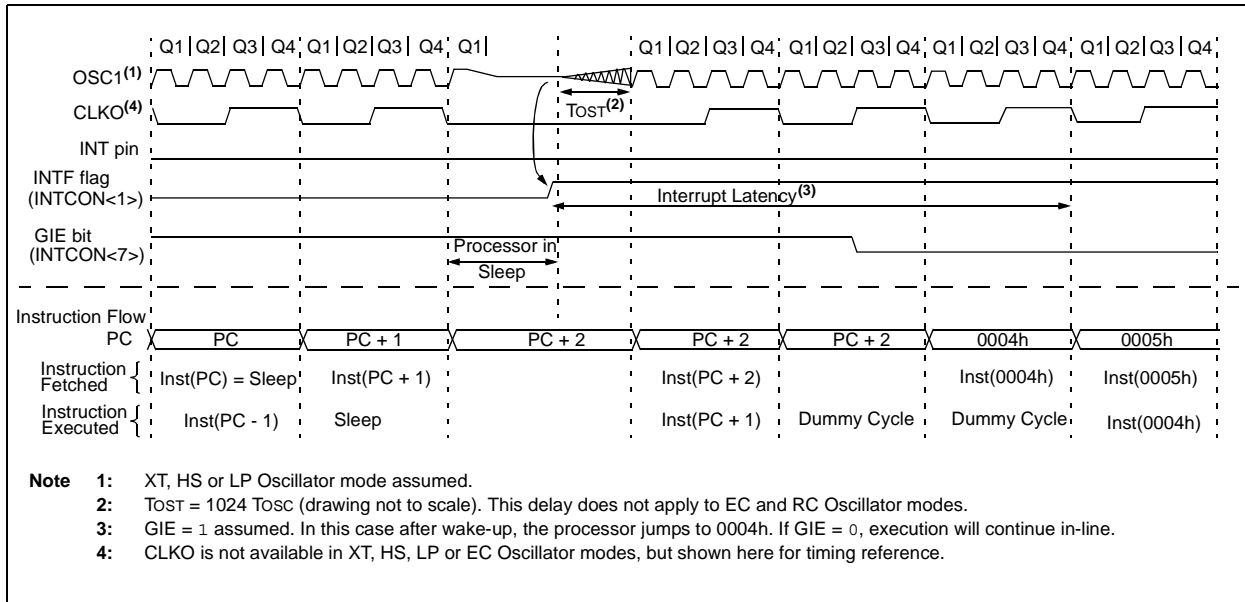

16.8 Code Protection

If the code protection bit(s) have not been programmed, the on-chip program memory can be read out using ICSP for verification purposes.

Note: The entire data EEPROM and Flash program memory will be erased when the code protection is turned off. See the "PIC16F917/916/914/913 Memory Programming Specification" (DS41244) for more information.

16.9 ID Locations

Four memory locations (2000h-2003h) are designated as ID locations where the user can store checksum or other code identification numbers. These locations are not accessible during normal execution, but are readable and writable during Program/Verify mode. Only the Least Significant 7 bits of the ID locations are used.

16.10 In-Circuit Serial Programming

The PIC16F917/916/914/913 microcontrollers can be serially programmed while in the end application circuit. This is simply done with two lines for clock and data and three other lines for:

- power
- ground
- programming voltage

This allows customers to manufacture boards with unprogrammed devices and then program the microcontroller just before shipping the product. This also allows the most recent firmware or a custom firmware to be programmed.

The device is placed into a Program/Verify mode by holding the RB7/ICSPDAT/ICDDAT/SEG13 and RB6/ICSPCLK/ICDCK/SEG14 pins low, while raising the MCLR (VPP) pin from VIL to VIH. See "PIC16F917/916/914/913 Memory Programming Specification" (DS41244) for more information. RB7/ICSPDAT/ICDDAT/SEG13 becomes the programming data and RB6/ICSPCLK/ICDCK/SEG14 becomes the programming clock. Both RB7/ICSPDAT/ICDDAT/SEG13 and RB6/ICSPCLK/ICDCK/SEG14 are Schmitt Trigger inputs in this mode.

After Reset, to place the device into Program/Verify mode, the Program Counter (PC) is at location 00h. A 6-bit command is then supplied to the device. Depending on the command, 14 bits of program data are then supplied to or from the device, depending on whether the command was a load or a read. For complete details of serial programming, please refer to the "PIC16F917/916/914/913 Memory Programming Specification" (DS41244).

A typical In-Circuit Serial Programming connection is shown in Figure 16-11.

FIGURE 16-11: TYPICAL IN-CIRCUIT SERIAL PROGRAMMING CONNECTION

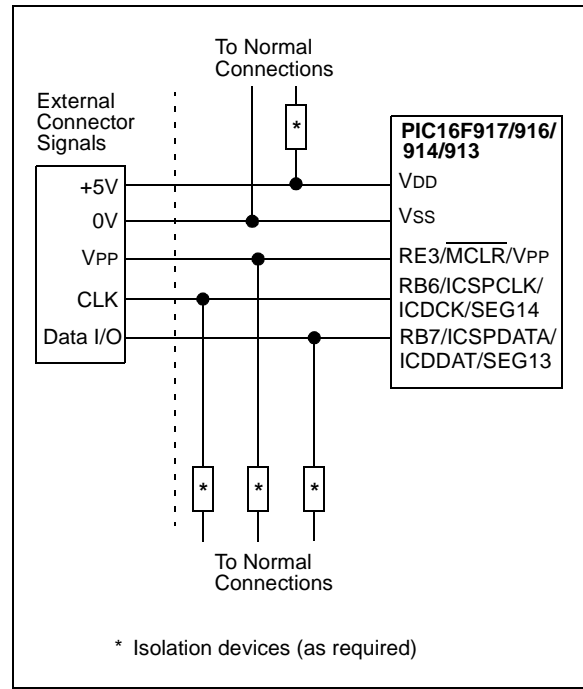

PIC16F917/916/914/913

16.11 In-Circuit Debugger

The PIC16F917/916/914/913-ICD can be used in any of the package types. The device will be mounted on the target application board, which in turn has a 3 or 4 wire connection to the ICD tool.

When the debug bit in the Configuration Word (CONFIG<12>) is programmed to a '0', the In-Circuit Debugger functionality is enabled. This function allows simple debugging functions when used with MPLAB® ICD 2. When the microcontroller has this feature enabled, some of the resources are not available for general use. See Table 16-9 for more detail.

Note: The user's application must have the circuitry required to support ICD functionality. Once the ICD circuitry is enabled, normal device pin functions on RB6/ICSPCLK/ICDCK/SEG14 and RB7/ICSPDAT/ICDDAT/SEG13 will not be usable. The ICD circuitry uses these pins for communication with the ICD2 external debugger.

For more information, see "Using MPLAB® ICD 2" (DS51265), available on Microchip's web site (www.microchip.com).

16.11.1 ICD PINOUT

The devices in the PIC16F91X family carry the circuitry for the In-Circuit Debugger on-chip and on existing device pins. This eliminates the need for a separate die or package for the ICD device. The pinout for the ICD device is the same as the devices (see **Section 1.0 "Device Overview"** for complete pinout and pin descriptions). Table 16-9 shows the location and function of the ICD related pins on the 28 and 40 pin devices.

TABLE 16-9: PIC16F917/916/914/913-ICD PIN DESCRIPTIONS

Pin (PDIP)		Name	Type	Pull-up	Description
PIC16F914/917	PIC16F913/916				
40	28	ICDDATA	TTL	—	In Circuit Debugger Bidirectional data
39	27	ICDCLK	ST	—	In Circuit Debugger Bidirectional clock
1	1	$\overline{\text{MCLR}}/\text{VPP}$	HV	—	Programming voltage
11,32	20	VDD	P	—	
12,31	8,19	VSS	P	—	

Legend: TTL = TTL input buffer, ST = Schmitt Trigger input buffer, P = Power, HV = High Voltage

17.0 INSTRUCTION SET SUMMARY

The PIC16F917/916/914/913 instruction set is highly orthogonal and is comprised of three basic categories:

- **Byte-oriented** operations
- **Bit-oriented** operations
- **Literal and control** operations

Each PIC16 instruction is a 14-bit word divided into an **opcode**, which specifies the instruction type and one or more **operands**, which further specify the operation of the instruction. The formats for each of the categories is presented in Figure 17-1, while the various opcode fields are summarized in Table 17-1.

Table 17-2 lists the instructions recognized by the MPASM™ assembler. A complete description of each instruction is also available in the “*PICmicro® Mid-Range MCU Family Reference Manual*” (DS33023).

For **byte-oriented** instructions, ‘f’ represents a file register designator and ‘d’ represents a destination designator. The file register designator specifies which file register is to be used by the instruction.

The destination designator specifies where the result of the operation is to be placed. If ‘d’ is zero, the result is placed in the W register. If ‘d’ is one, the result is placed in the file register specified in the instruction.

For **bit-oriented** instructions, ‘b’ represents a bit field designator, which selects the bit affected by the operation, while ‘f’ represents the address of the file in which the bit is located.

For **literal and control** operations, ‘k’ represents an 8-bit or 11-bit constant, or literal value.

One instruction cycle consists of four oscillator periods; for an oscillator frequency of 4 MHz, this gives a normal instruction execution time of 1 μs. All instructions are executed within a single instruction cycle, unless a conditional test is true, or the program counter is changed as a result of an instruction. When this occurs, the execution takes two instruction cycles, with the second cycle executed as a NOP.

Note: To maintain upward compatibility with future products, do not use the `OPTION` and `TRIS` instructions.

All instruction examples use the format ‘0xhh’ to represent a hexadecimal number, where ‘h’ signifies a hexadecimal digit.

17.1 READ-MODIFY-WRITE OPERATIONS

Any instruction that specifies a file register as part of the instruction performs a Read-Modify-Write (R-M-W) operation. The register is read, the data is modified, and the result is stored according to either the instruction, or the destination designator ‘d’. A read operation is performed on a register even if the instruction writes to that register.

For example, a `CLRF GPIO` instruction will read GPIO, clear all the data bits, then write the result back to GPIO. This example would have the unintended result of clearing the condition that set the GPIF flag.

TABLE 17-1: OPCODE FIELD DESCRIPTIONS

Field	Description
f	Register file address (0x00 to 0x7F)
w	Working register (accumulator)
b	Bit address within an 8-bit file register
k	Literal field, constant data or label
x	Don't care location (= 0 or 1). The assembler will generate code with x = 0. It is the recommended form of use for compatibility with all Microchip software tools.
d	Destination select; d = 0: store result in W, d = 1: store result in file register f. Default is d = 1.
PC	Program Counter
TO	Time-out bit
PD	Power-down bit

PIC16F917/916/914/913

FIGURE 17-1: GENERAL FORMAT FOR INSTRUCTIONS

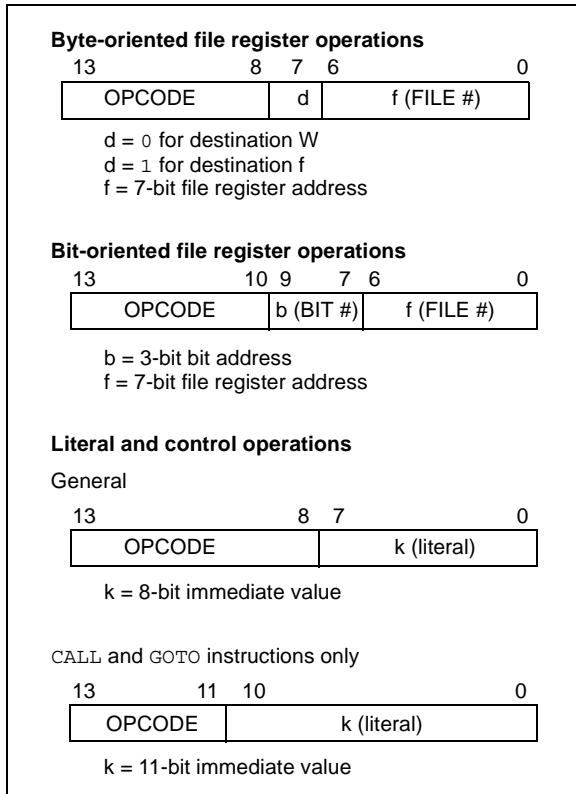

PIC16F917/916/914/913

TABLE 17-2: PIC16F917/916/914/913 INSTRUCTION SET

Mnemonic, Operands	Description	Cycles	14-Bit Opcode				Status Affected	Notes	
			MSb	LSb					
BYTE-ORIENTED FILE REGISTER OPERATIONS									
ADDWF	f, d	Add W and f	1	00	0111	dfff	ffff	C,DC,Z	1, 2
ANDWF	f, d	AND W with f	1	00	0101	dfff	ffff	Z	1, 2
CLRF	f	Clear f	1	00	0001	1fff	ffff	Z	2
CLRWF	-	Clear W	1	00	0001	0xxx	xxxx	Z	
COMF	f, d	Complement f	1	00	1001	dfff	ffff	Z	1, 2
DECF	f, d	Decrement f	1	00	0011	dfff	ffff	Z	1, 2
DECFSZ	f, d	Decrement f, Skip if 0	1(2)	00	1011	dfff	ffff		1, 2, 3
INCF	f, d	Increment f	1	00	1010	dfff	ffff	Z	1, 2
INCSZ	f, d	Increment f, Skip if 0	1(2)	00	1111	dfff	ffff		1, 2, 3
IORWF	f, d	Inclusive OR W with f	1	00	0100	dfff	ffff	Z	1, 2
MOVF	f, d	Move f	1	00	1000	dfff	ffff	Z	1, 2
MOVWF	f	Move W to f	1	00	0000	1fff	ffff		
NOP	-	No Operation	1	00	0000	0xx0	0000		
RLF	f, d	Rotate Left f through Carry	1	00	1101	dfff	ffff	C	1, 2
RRF	f, d	Rotate Right f through Carry	1	00	1100	dfff	ffff	C	1, 2
SUBWF	f, d	Subtract W from f	1	00	0010	dfff	ffff	C,DC,Z	1, 2
SWAPF	f, d	Swap nibbles in f	1	00	1110	dfff	ffff		1, 2
XORWF	f, d	Exclusive OR W with f	1	00	0110	dfff	ffff	Z	1, 2
BIT-ORIENTED FILE REGISTER OPERATIONS									
BCF	f, b	Bit Clear f	1	01	00bb	bfff	ffff		1, 2
BSF	f, b	Bit Set f	1	01	01bb	bfff	ffff		1, 2
BTFSC	f, b	Bit Test f, Skip if Clear	1(2)	01	10bb	bfff	ffff		3
BTFSS	f, b	Bit Test f, Skip if Set	1(2)	01	11bb	bfff	ffff		3
LITERAL AND CONTROL OPERATIONS									
ADDLW	k	Add literal and W	1	11	111x	kkkk	kkkk	C,DC,Z	
ANDLW	k	AND literal with W	1	11	1001	kkkk	kkkk	Z	
CALL	k	Call subroutine	2	10	0kkk	kkkk	kkkk		
CLRWDT	-	Clear Watchdog Timer	1	00	0000	0110	0100	$\overline{TO,PD}$	
GOTO	k	Go to address	2	10	1kkk	kkkk	kkkk		
IORLW	k	Inclusive OR literal with W	1	11	1000	kkkk	kkkk	Z	
MOVLW	k	Move literal to W	1	11	00xx	kkkk	kkkk		
RETFIE	-	Return from interrupt	2	00	0000	0000	1001		
RETLW	k	Return with literal in W	2	11	01xx	kkkk	kkkk		
RETURN	-	Return from Subroutine	2	00	0000	0000	1000		
SLEEP	-	Go into Standby mode	1	00	0000	0110	0011	$\overline{TO,PD}$	
SUBLW	k	Subtract W from literal	1	11	110x	kkkk	kkkk	C,DC,Z	
XORLW	k	Exclusive OR literal with W	1	11	1010	kkkk	kkkk	Z	

- Note 1:** When an I/O register is modified as a function of itself (e.g., `MOVF GPIO, 1`), the value used will be that value present on the pins themselves. For example, if the data latch is '1' for a pin configured as input and is driven low by an external device, the data will be written back with a '0'.
- 2:** If this instruction is executed on the TMR0 register (and where applicable, d = 1), the prescaler will be cleared if assigned to the Timer0 module.
- 3:** If Program Counter (PC) is modified, or a conditional test is true, the instruction requires two cycles. The second cycle is executed as a NOP.

Note: Additional information on the mid-range instruction set is available in the *PICmicro® Mid-Range MCU Family Reference Manual* (DS33023).

PIC16F917/916/914/913

17.2 Instruction Descriptions

ADDLW	Add Literal and W	BCF	Bit Clear f
Syntax:	[<i>label</i>] ADDLW k	Syntax:	[<i>label</i>] BCF f,b
Operands:	$0 \leq k \leq 255$	Operands:	$0 \leq f \leq 127$ $0 \leq b \leq 7$
Operation:	$(W) + k \rightarrow (W)$	Operation:	$0 \rightarrow (f)$
Status Affected:	C, DC, Z	Status Affected:	None
Description:	The contents of the W register are added to the eight-bit literal 'k' and the result is placed in the W register.	Description:	Bit 'b' in register 'f' is cleared.
ADDWF	Add W and f	BSF	Bit Set f
Syntax:	[<i>label</i>] ADDWF f,d	Syntax:	[<i>label</i>] BSF f,b
Operands:	$0 \leq f \leq 127$ $d \in [0,1]$	Operands:	$0 \leq f \leq 127$ $0 \leq b \leq 7$
Operation:	$(W) + (f) \rightarrow (\text{destination})$	Operation:	$1 \rightarrow (f)$
Status Affected:	C, DC, Z	Status Affected:	None
Description:	Add the contents of the W register with register 'f'. If 'd' is '0', the result is stored in the W register. If 'd' is '1', the result is stored back in register 'f'.	Description:	Bit 'b' in register 'f' is set.
ANDLW	AND Literal with W	BTFSC	Bit Test, Skip if Clear
Syntax:	[<i>label</i>] ANDLW k	Syntax:	[<i>label</i>] BTFSC f,b
Operands:	$0 \leq k \leq 255$	Operands:	$0 \leq f \leq 127$ $0 \leq b \leq 7$
Operation:	$(W) .\text{AND.} (k) \rightarrow (W)$	Operation:	skip if $(f) = 0$
Status Affected:	Z	Status Affected:	None
Description:	The contents of W register are AND'ed with the eight-bit literal 'k'. The result is placed in the W register.	Description:	If bit 'b' in register 'f' is '1', the next instruction is executed. If bit 'b' in register 'f' is '0', the next instruction is discarded, and a NOP is executed instead, making this a two-cycle instruction.
ANDWF	AND W with f		
Syntax:	[<i>label</i>] ANDWF f,d		
Operands:	$0 \leq f \leq 127$ $d \in [0,1]$		
Operation:	$(W) .\text{AND.} (f) \rightarrow (\text{destination})$		
Status Affected:	Z		
Description:	AND the W register with register 'f'. If 'd' is '0', the result is stored in the W register. If 'd' is '1', the result is stored back in register 'f'.		

PIC16F917/916/914/913

BTFSS	Bit Test f, Skip if Set
Syntax:	[<i>label</i>] BTFSS f,b
Operands:	0 ≤ f ≤ 127 0 ≤ b < 7
Operation:	skip if (f) = 1
Status Affected:	None
Description:	If bit 'b' in register 'f' is '0', the next instruction is executed. If bit 'b' is '1', then the next instruction is discarded and a NOP is executed instead, making this a two-cycle instruction.

CLRWDT	Clear Watchdog Timer
Syntax:	[<i>label</i>] CLRWDT
Operands:	None
Operation:	00h → WDT 0 → WDT prescaler, 1 → \overline{TO} 1 → \overline{PD}
Status Affected:	\overline{TO} , \overline{PD}
Description:	CLRWDT instruction resets the Watchdog Timer. It also resets the prescaler of the WDT. Status bits \overline{TO} and \overline{PD} are set.

CALL	Call Subroutine
Syntax:	[<i>label</i>] CALL k
Operands:	0 ≤ k ≤ 2047
Operation:	(PC)+ 1 → TOS, k → PC<10:0>, (PCLATH<4:3>) → PC<12:11>
Status Affected:	None
Description:	Call Subroutine. First, return address (PC + 1) is pushed onto the stack. The eleven-bit immediate address is loaded into PC bits <10:0>. The upper bits of the PC are loaded from PCLATH. CALL is a two-cycle instruction.

COMF	Complement f
Syntax:	[<i>label</i>] COMF f,d
Operands:	0 ≤ f ≤ 127 d ∈ [0,1]
Operation:	(\bar{f}) → (destination)
Status Affected:	Z
Description:	The contents of register 'f' are complemented. If 'd' is '0', the result is stored in W. If 'd' is '1', the result is stored back in register 'f'.

CLRF	Clear f
Syntax:	[<i>label</i>] CLRF f
Operands:	0 ≤ f ≤ 127
Operation:	00h → (f) 1 → Z
Status Affected:	Z
Description:	The contents of register 'f' are cleared and the Z bit is set.

DECF	Decrement f
Syntax:	[<i>label</i>] DECF f,d
Operands:	0 ≤ f ≤ 127 d ∈ [0,1]
Operation:	(f) - 1 → (destination)
Status Affected:	Z
Description:	Decrement register 'f'. If 'd' is '0', the result is stored in the W register. If 'd' is '1', the result is stored back in register 'f'.

CLRW	Clear W
Syntax:	[<i>label</i>] CLRW
Operands:	None
Operation:	00h → (W) 1 → Z
Status Affected:	Z
Description:	W register is cleared. Zero bit (Z) is set.

PIC16F917/916/914/913

DECFSZ **Decrement f, Skip if 0**

Syntax: [*label*] DECFSZ f,d

Operands: $0 \leq f \leq 127$
 $d \in [0,1]$

Operation: (f) - 1 → (destination);
 skip if result = 0

Status Affected: None

Description: The contents of register 'f' are decremented. If 'd' is '0', the result is placed in the W register. If 'd' is '1', the result is placed back in register 'f'.
 If the result is '1', the next instruction is executed. If the result is '0', then a NOP is executed instead, making it a two-cycle instruction.

INCFSZ **Increment f, Skip if 0**

Syntax: [*label*] INCFSZ f,d

Operands: $0 \leq f \leq 127$
 $d \in [0,1]$

Operation: (f) + 1 → (destination),
 skip if result = 0

Status Affected: None

Description: The contents of register 'f' are incremented. If 'd' is '0', the result is placed in the W register. If 'd' is '1', the result is placed back in register 'f'.
 If the result is '1', the next instruction is executed. If the result is '0', a NOP is executed instead, making it a two-cycle instruction.

GOTO **Go to Address**

Syntax: [*label*] GOTO k

Operands: $0 \leq k \leq 2047$

Operation: $k \rightarrow PC<10:0>$
 $PCLATH<4:3> \rightarrow PC<12:11>$

Status Affected: None

Description: GOTO is an unconditional branch. The eleven-bit immediate value is loaded into PC bits <10:0>. The upper bits of PC are loaded from PCLATH<4:3>. GOTO is a two-cycle instruction.

IORLW **Inclusive OR Literal with W**

Syntax: [*label*] IORLW k

Operands: $0 \leq k \leq 255$

Operation: (W) .OR. k → (W)

Status Affected: Z

Description: The contents of the W register are OR'ed with the eight-bit literal 'k'. The result is placed in the W register.

INCF **Increment f**

Syntax: [*label*] INCF f,d

Operands: $0 \leq f \leq 127$
 $d \in [0,1]$

Operation: (f) + 1 → (destination)

Status Affected: Z

Description: The contents of register 'f' are incremented. If 'd' is '0', the result is placed in the W register. If 'd' is '1', the result is placed back in register 'f'.

IORWF **Inclusive OR W with f**

Syntax: [*label*] IORWF f,d

Operands: $0 \leq f \leq 127$
 $d \in [0,1]$

Operation: (W) .OR. (f) → (destination)

Status Affected: Z

Description: Inclusive OR the W register with register 'f'. If 'd' is '0', the result is placed in the W register. If 'd' is '1', the result is placed back in register 'f'.

MOVF	Move f				
Syntax:	[<i>label</i>] MOVF f,d				
Operands:	0 ≤ f ≤ 127 d ∈ [0,1]				
Operation:	(f) → (dest)				
Status Affected:	Z				
Encoding:	<table border="1" style="display: inline-table; border-collapse: collapse;"> <tr> <td style="padding: 2px 10px;">00</td> <td style="padding: 2px 10px;">1000</td> <td style="padding: 2px 10px;">dfff</td> <td style="padding: 2px 10px;">ffff</td> </tr> </table>	00	1000	dfff	ffff
00	1000	dfff	ffff		
Description:	The contents of register 'f' is moved to a destination dependent upon the status of 'd'. If 'd' = 0, destination is W register. If 'd' = 1, the destination is file register 'f' itself. 'd' = 1 is useful to test a file register since status flag Z is affected.				
Words:	1				
Cycles:	1				
Example:	MOVF FSR, 0 After Instruction W = value in FSR register Z = 1				

MOVWF	Move W to f				
Syntax:	[<i>label</i>] MOVWF f				
Operands:	0 ≤ f ≤ 127				
Operation:	(W) → (f)				
Status Affected:	None				
Encoding:	<table border="1" style="display: inline-table; border-collapse: collapse;"> <tr> <td style="padding: 2px 10px;">00</td> <td style="padding: 2px 10px;">0000</td> <td style="padding: 2px 10px;">1fff</td> <td style="padding: 2px 10px;">ffff</td> </tr> </table>	00	0000	1fff	ffff
00	0000	1fff	ffff		
Description:	Move data from W register to register 'f'.				
Words:	1				
Cycles:	1				
Example:	MOVWF OPTION Before Instruction OPTION = 0xFF W = 0x4F After Instruction OPTION = 0x4F W = 0x4F				

MOVLW	Move Literal to W				
Syntax:	[<i>label</i>] MOVLW k				
Operands:	0 ≤ k ≤ 255				
Operation:	k → (W)				
Status Affected:	None				
Encoding:	<table border="1" style="display: inline-table; border-collapse: collapse;"> <tr> <td style="padding: 2px 10px;">11</td> <td style="padding: 2px 10px;">00xx</td> <td style="padding: 2px 10px;">kkkk</td> <td style="padding: 2px 10px;">kkkk</td> </tr> </table>	11	00xx	kkkk	kkkk
11	00xx	kkkk	kkkk		
Description:	The eight bit literal 'k' is loaded into W register. The "don't cares" will assemble as '0's.				
Words:	1				
Cycles:	1				
Example:	MOVLW 0x5A After Instruction W = 0x5A				

NOP	No Operation				
Syntax:	[<i>label</i>] NOP				
Operands:	None				
Operation:	No operation				
Status Affected:	None				
Encoding:	<table border="1" style="display: inline-table; border-collapse: collapse;"> <tr> <td style="padding: 2px 10px;">00</td> <td style="padding: 2px 10px;">0000</td> <td style="padding: 2px 10px;">0xx0</td> <td style="padding: 2px 10px;">0000</td> </tr> </table>	00	0000	0xx0	0000
00	0000	0xx0	0000		
Description:	No operation.				
Words:	1				
Cycles:	1				
Example:	NOP				

PIC16F917/916/914/913

RETFIE Return from Interrupt

Syntax: [*label*] RETFIE

Operands: None

Operation: TOS → PC,
 1 → GIE

Status Affected: None

Encoding:

00	0000	0000	1001
----	------	------	------

Description: Return from Interrupt. Stack is POPed and Top-of-Stack (TOS) is loaded in the PC. Interrupts are enabled by setting Global Interrupt Enable bit, GIE (INTCON<7>). This is a two-cycle instruction.

Words: 1

Cycles: 2

Example: RETFIE

 After Interrupt

 PC = TOS

 GIE = 1

RETLW Return with Literal in W

Syntax: [*label*] RETLW k

Operands: $0 \leq k \leq 255$

Operation: $k \rightarrow (W)$;
 TOS → PC

Status Affected: None

Encoding:

11	01xx	kkkk	kkkk
----	------	------	------

Description: The W register is loaded with the eight bit literal 'k'. The program counter is loaded from the top of the stack (the return address). This is a two-cycle instruction.

Words: 1

Cycles: 2

Example: CALL TABLE ;W contains table
 ;offset value

- ;W now has table
- TABLE value
-
-
- ADDWF PC ;W = offset
- RETLW k1 ;Begin table
- RETLW k2 ;
-
-
-
- RETLW kn ; End of table

Before Instruction
 W = 0x07

After Instruction
 W = value of k8

RETURN Return from Subroutine

Syntax: [*label*] RETURN

Operands: None

Operation: TOS → PC

Status Affected: None

Description: Return from subroutine. The stack is POPed and the top of the stack (TOS) is loaded into the program counter. This is a two-cycle instruction.

RLF Rotate Left f through Carry

Syntax: [*label*] RLF f,d

Operands: $0 \leq f \leq 127$
 $d \in [0,1]$

Operation: See description below

Status Affected: C

Encoding:

00	1101	dfff	ffff
----	------	------	------

Description: The contents of register 'f' are rotated one bit to the left through the Carry Flag. If 'd' is '0', the result is placed in the W register. If 'd' is '1', the result is stored back in register 'f'.

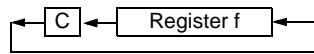

Words: 1

Cycles: 1

Example:

```
RLF    REG1,0
```

Before Instruction

REG1	=	1110 0110
C	=	0

After Instruction

REG1	=	1110 0110
W	=	1100 1100
C	=	1

RRF Rotate Right f through Carry

Syntax: [*label*] RRF f,d

Operands: $0 \leq f \leq 127$
 $d \in [0,1]$

Operation: See description below

Status Affected: C

Description: The contents of register 'f' are rotated one bit to the right through the Carry Flag. If 'd' is '0', the result is placed in the W register. If 'd' is '1', the result is placed back in register 'f'.

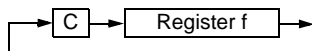

SLEEP

Syntax: [*label*] SLEEP

Operands: None

Operation: 00h → WDT,
0 → WDT prescaler,
1 → \overline{TO} ,
0 → \overline{PD}

Status Affected: \overline{TO} , \overline{PD}

Description: The power-down Status bit, \overline{PD} is cleared. Time-out Status bit, \overline{TO} is set. Watchdog Timer and its prescaler are cleared. The processor is put into Sleep mode with the oscillator stopped.

SUBLW Subtract W from Literal

Syntax: [*label*] SUBLW k

Operands: $0 \leq k \leq 255$

Operation: $k - (W) \rightarrow (W)$

Status Affected: C, DC, Z

Description: The W register is subtracted (2's complement method) from the eight-bit literal 'k'. The result is placed in the W register.

SUBWF Subtract W from f

Syntax: [*label*] SUBWF f,d

Operands: $0 \leq f \leq 127$
 $d \in [0,1]$

Operation: $(f) - (W) \rightarrow (\text{destination})$

Status Affected: C, DC, Z

Description: Subtract (2's complement method) W register from register 'f'. If 'd' is '0', the result is stored in the W register. If 'd' is '1', the result is stored back in register 'f'.

PIC16F917/916/914/913

SWAPF **Swap Nibbles in f**

Syntax: [*label*] SWAPF f,d

Operands: $0 \leq f \leq 127$
 $d \in [0,1]$

Operation: ($f<3:0>$) \rightarrow (destination<7:4>),
 ($f<7:4>$) \rightarrow (destination<3:0>)

Status Affected: None

Description: The upper and lower nibbles of register 'f' are exchanged. If 'd' is '0', the result is placed in the W register. If 'd' is '1', the result is placed in register 'f'.

XORLW **Exclusive OR Literal with W**

Syntax: [*label*] XORLW k

Operands: $0 \leq k \leq 255$

Operation: (W) .XOR. k \rightarrow (W)

Status Affected: Z

Description: The contents of the W register are XOR'ed with the eight-bit literal 'k'. The result is placed in the W register.

XORWF **Exclusive OR W with f**

Syntax: [*label*] XORWF f,d

Operands: $0 \leq f \leq 127$
 $d \in [0,1]$

Operation: (W) .XOR. (f) \rightarrow (destination)

Status Affected: Z

Description: Exclusive OR the contents of the W register with register 'f'. If 'd' is '0', the result is stored in the W register. If 'd' is '1', the result is stored back in register 'f'.

18.0 DEVELOPMENT SUPPORT

The PICmicro® microcontrollers are supported with a full range of hardware and software development tools:

- Integrated Development Environment
 - MPLAB® IDE Software
- Assemblers/Compilers/Linkers
 - MPASM™ Assembler
 - MPLAB C17 and MPLAB C18 C Compilers
 - MPLINK™ Object Linker/
MPLIB™ Object Librarian
 - MPLAB C30 C Compiler
 - MPLAB ASM30 Assembler/Linker/Library
- Simulators
 - MPLAB SIM Software Simulator
 - MPLAB dsPIC30 Software Simulator
- Emulators
 - MPLAB ICE 2000 In-Circuit Emulator
 - MPLAB ICE 4000 In-Circuit Emulator
- In-Circuit Debugger
 - MPLAB ICD 2
- Device Programmers
 - PRO MATE® II Universal Device Programmer
 - PICSTART® Plus Development Programmer
 - MPLAB PM3 Device Programmer
- Low-Cost Demonstration Boards
 - PICDEM™ 1 Demonstration Board
 - PICDEM.net™ Demonstration Board
 - PICDEM 2 Plus Demonstration Board
 - PICDEM 3 Demonstration Board
 - PICDEM 4 Demonstration Board
 - PICDEM 17 Demonstration Board
 - PICDEM 18R Demonstration Board
 - PICDEM LIN Demonstration Board
 - PICDEM USB Demonstration Board
- Evaluation Kits
 - KEELOQ® Security ICs
 - PICDEM MSC
 - microID® RFID
 - CAN
 - PowerSmart® Battery Management
 - Analog

18.1 MPLAB Integrated Development Environment Software

The MPLAB IDE software brings an ease of software development previously unseen in the 8/16-bit microcontroller market. The MPLAB IDE is a Windows® based application that contains:

- An interface to debugging tools
 - simulator
 - programmer (sold separately)
 - emulator (sold separately)
 - in-circuit debugger (sold separately)
- A full-featured editor with color coded context
- A multiple project manager
- Customizable data windows with direct edit of contents
- High-level source code debugging
- Mouse over variable inspection
- Extensive on-line help

The MPLAB IDE allows you to:

- Edit your source files (either assembly or C)
- One touch assemble (or compile) and download to PICmicro emulator and simulator tools (automatically updates all project information)
- Debug using:
 - source files (assembly or C)
 - mixed assembly and C
 - machine code

MPLAB IDE supports multiple debugging tools in a single development paradigm, from the cost effective simulators, through low-cost in-circuit debuggers, to full-featured emulators. This eliminates the learning curve when upgrading to tools with increasing flexibility and power.

18.2 MPASM Assembler

The MPASM assembler is a full-featured, universal macro assembler for all PICmicro MCUs.

The MPASM assembler generates relocatable object files for the MPLINK object linker, Intel® standard hex files, MAP files to detail memory usage and symbol reference, absolute LST files that contain source lines and generated machine code and COFF files for debugging.

The MPASM assembler features include:

- Integration into MPLAB IDE projects
- User defined macros to streamline assembly code
- Conditional assembly for multi-purpose source files
- Directives that allow complete control over the assembly process

PIC16F917/916/914/913

18.3 MPLAB C17 and MPLAB C18 C Compilers

The MPLAB C17 and MPLAB C18 Code Development Systems are complete ANSI C compilers for Microchip's PIC17CXXX and PIC18CXXX family of microcontrollers. These compilers provide powerful integration capabilities, superior code optimization and ease of use not found with other compilers.

For easy source level debugging, the compilers provide symbol information that is optimized to the MPLAB IDE debugger.

18.4 MPLINK Object Linker/ MPLIB Object Librarian

The MPLINK object linker combines relocatable objects created by the MPASM assembler and the MPLAB C17 and MPLAB C18 C compilers. It can link relocatable objects from precompiled libraries, using directives from a linker script.

The MPLIB object librarian manages the creation and modification of library files of precompiled code. When a routine from a library is called from a source file, only the modules that contain that routine will be linked in with the application. This allows large libraries to be used efficiently in many different applications.

The object linker/librarian features include:

- Efficient linking of single libraries instead of many smaller files
- Enhanced code maintainability by grouping related modules together
- Flexible creation of libraries with easy module listing, replacement, deletion and extraction

18.5 MPLAB C30 C Compiler

The MPLAB C30 C compiler is a full-featured, ANSI compliant, optimizing compiler that translates standard ANSI C programs into dsPIC30F assembly language source. The compiler also supports many command line options and language extensions to take full advantage of the dsPIC30F device hardware capabilities and afford fine control of the compiler code generator.

MPLAB C30 is distributed with a complete ANSI C standard library. All library functions have been validated and conform to the ANSI C library standard. The library includes functions for string manipulation, dynamic memory allocation, data conversion, time-keeping and math functions (trigonometric, exponential and hyperbolic). The compiler provides symbolic information for high-level source debugging with the MPLAB IDE.

18.6 MPLAB ASM30 Assembler, Linker and Librarian

MPLAB ASM30 assembler produces relocatable machine code from symbolic assembly language for dsPIC30F devices. MPLAB C30 compiler uses the assembler to produce its object file. The assembler generates relocatable object files that can then be archived or linked with other relocatable object files and archives to create an executable file. Notable features of the assembler include:

- Support for the entire dsPIC30F instruction set
- Support for fixed-point and floating-point data
- Command line interface
- Rich directive set
- Flexible macro language
- MPLAB IDE compatibility

18.7 MPLAB SIM Software Simulator

The MPLAB SIM software simulator allows code development in a PC hosted environment by simulating the PICmicro series microcontrollers on an instruction level. On any given instruction, the data areas can be examined or modified and stimuli can be applied from a file, or user defined key press, to any pin. The execution can be performed in Single-Step, Execute Until Break or Trace mode.

The MPLAB SIM simulator fully supports symbolic debugging using the MPLAB C17 and MPLAB C18 C Compilers, as well as the MPASM assembler. The software simulator offers the flexibility to develop and debug code outside of the laboratory environment, making it an excellent, economical software development tool.

18.8 MPLAB SIM30 Software Simulator

The MPLAB SIM30 software simulator allows code development in a PC hosted environment by simulating the dsPIC30F series microcontrollers on an instruction level. On any given instruction, the data areas can be examined or modified and stimuli can be applied from a file, or user defined key press, to any of the pins.

The MPLAB SIM30 simulator fully supports symbolic debugging using the MPLAB C30 C Compiler and MPLAB ASM30 assembler. The simulator runs in either a Command Line mode for automated tasks, or from MPLAB IDE. This high-speed simulator is designed to debug, analyze and optimize time intensive DSP routines.

18.9 MPLAB ICE 2000 High-Performance Universal In-Circuit Emulator

The MPLAB ICE 2000 universal in-circuit emulator is intended to provide the product development engineer with a complete microcontroller design tool set for PICmicro microcontrollers. Software control of the MPLAB ICE 2000 in-circuit emulator is advanced by the MPLAB Integrated Development Environment, which allows editing, building, downloading and source debugging from a single environment.

The MPLAB ICE 2000 is a full-featured emulator system with enhanced trace, trigger and data monitoring features. Interchangeable processor modules allow the system to be easily reconfigured for emulation of different processors. The universal architecture of the MPLAB ICE in-circuit emulator allows expansion to support new PICmicro microcontrollers.

The MPLAB ICE 2000 in-circuit emulator system has been designed as a real-time emulation system with advanced features that are typically found on more expensive development tools. The PC platform and Microsoft® Windows 32-bit operating system were chosen to best make these features available in a simple, unified application.

18.10 MPLAB ICE 4000 High-Performance Universal In-Circuit Emulator

The MPLAB ICE 4000 universal in-circuit emulator is intended to provide the product development engineer with a complete microcontroller design tool set for high-end PICmicro microcontrollers. Software control of the MPLAB ICE in-circuit emulator is provided by the MPLAB Integrated Development Environment, which allows editing, building, downloading and source debugging from a single environment.

The MPLAB ICE 4000 is a premium emulator system, providing the features of MPLAB ICE 2000, but with increased emulation memory and high-speed performance for dsPIC30F and PIC18XXXX devices. Its advanced emulator features include complex triggering and timing, up to 2 Mb of emulation memory and the ability to view variables in real-time.

The MPLAB ICE 4000 in-circuit emulator system has been designed as a real-time emulation system with advanced features that are typically found on more expensive development tools. The PC platform and Microsoft Windows 32-bit operating system were chosen to best make these features available in a simple, unified application.

18.11 MPLAB ICD 2 In-Circuit Debugger

Microchip's In-Circuit Debugger, MPLAB ICD 2, is a powerful, low-cost, run-time development tool, connecting to the host PC via an RS-232 or high-speed USB interface. This tool is based on the Flash PICmicro MCUs and can be used to develop for these and other PICmicro microcontrollers. The MPLAB ICD 2 utilizes the in-circuit debugging capability built into the Flash devices. This feature, along with Microchip's In-Circuit Serial Programming™ (ICSP™) protocol, offers cost effective in-circuit Flash debugging from the graphical user interface of the MPLAB Integrated Development Environment. This enables a designer to develop and debug source code by setting breakpoints, single-stepping and watching variables, CPU status and peripheral registers. Running at full speed enables testing hardware and applications in real-time. MPLAB ICD 2 also serves as a development programmer for selected PICmicro devices.

18.12 PRO MATE II Universal Device Programmer

The PRO MATE II is a universal, CE compliant device programmer with programmable voltage verification at VDDMIN and VDDMAX for maximum reliability. It features an LCD display for instructions and error messages and a modular detachable socket assembly to support various package types. In Stand-Alone mode, the PRO MATE II device programmer can read, verify and program PICmicro devices without a PC connection. It can also set code protection in this mode.

18.13 MPLAB PM3 Device Programmer

The MPLAB PM3 is a universal, CE compliant device programmer with programmable voltage verification at VDDMIN and VDDMAX for maximum reliability. It features a large LCD display (128 x 64) for menus and error messages and a modular detachable socket assembly to support various package types. The ICSP™ cable assembly is included as a standard item. In Stand-Alone mode, the MPLAB PM3 device programmer can read, verify and program PICmicro devices without a PC connection. It can also set code protection in this mode. MPLAB PM3 connects to the host PC via an RS-232 or USB cable. MPLAB PM3 has high-speed communications and optimized algorithms for quick programming of large memory devices and incorporates an SD/MMC card for file storage and secure data applications.

PIC16F917/916/914/913

18.14 PICSTART Plus Development Programmer

The PICSTART Plus development programmer is an easy-to-use, low-cost, prototype programmer. It connects to the PC via a COM (RS-232) port. MPLAB Integrated Development Environment software makes using the programmer simple and efficient. The PICSTART Plus development programmer supports most PICmicro devices up to 40 pins. Larger pin count devices, such as the PIC16C92X and PIC17C76X, may be supported with an adapter socket. The PICSTART Plus development programmer is CE compliant.

18.15 PICDEM 1 PICmicro Demonstration Board

The PICDEM 1 demonstration board demonstrates the capabilities of the PIC16C5X (PIC16C54 to PIC16C58A), PIC16C61, PIC16C62X, PIC16C71, PIC16C8X, PIC17C42, PIC17C43 and PIC17C44. All necessary hardware and software is included to run basic demo programs. The sample microcontrollers provided with the PICDEM 1 demonstration board can be programmed with a PRO MATE II device programmer or a PICSTART Plus development programmer. The PICDEM 1 demonstration board can be connected to the MPLAB ICE in-circuit emulator for testing. A prototype area extends the circuitry for additional application components. Features include an RS-232 interface, a potentiometer for simulated analog input, push button switches and eight LEDs.

18.16 PICDEM.net Internet/Ethernet Demonstration Board

The PICDEM.net demonstration board is an Internet/Ethernet demonstration board using the PIC18F452 microcontroller and TCP/IP firmware. The board supports any 40-pin DIP device that conforms to the standard pinout used by the PIC16F877 or PIC18C452. This kit features a user friendly TCP/IP stack, web server with HTML, a 24L256 Serial EEPROM for Xmodem download to web pages into Serial EEPROM, ICSP/MPLAB ICD 2 interface connector, an Ethernet interface, RS-232 interface and a 16 x 2 LCD display. Also included is the book and CD-ROM "TCP/IP Lean, Web Servers for Embedded Systems," by Jeremy Bentham

18.17 PICDEM 2 Plus Demonstration Board

The PICDEM 2 Plus demonstration board supports many 18, 28 and 40-pin microcontrollers, including PIC16F87X and PIC18FXX2 devices. All the necessary hardware and software is included to run the demonstration programs. The sample microcontrollers provided with the PICDEM 2 demonstration board can be programmed with a PRO MATE II device programmer, PICSTART Plus development programmer, or MPLAB ICD 2 with a Universal Programmer Adapter. The MPLAB ICD 2 and MPLAB ICE in-circuit emulators may also be used with the PICDEM 2 demonstration board to test firmware. A prototype area extends the circuitry for additional application components. Some of the features include an RS-232 interface, a 2 x 16 LCD display, a piezo speaker, an on-board temperature sensor, four LEDs and sample PIC18F452 and PIC16F877 Flash microcontrollers.

18.18 PICDEM 3 PIC16C92X Demonstration Board

The PICDEM 3 demonstration board supports the PIC16C923 and PIC16C924 in the PLCC package. All the necessary hardware and software is included to run the demonstration programs.

18.19 PICDEM 4 8/14/18-Pin Demonstration Board

The PICDEM 4 can be used to demonstrate the capabilities of the 8, 14 and 18-pin PIC16XXXX and PIC18XXXX MCUs, including the PIC16F818/819, PIC16F87/88, PIC16F62XA and the PIC18F1320 family of microcontrollers. PICDEM 4 is intended to showcase the many features of these low pin count parts, including LIN and Motor Control using ECCP. Special provisions are made for low-power operation with the supercapacitor circuit and jumpers allow on-board hardware to be disabled to eliminate current draw in this mode. Included on the demo board are provisions for Crystal, RC or Canned Oscillator modes, a five volt regulator for use with a nine volt wall adapter or battery, DB-9 RS-232 interface, ICD connector for programming via ICSP and development with MPLAB ICD 2, 2 x 16 liquid crystal display, PCB footprints for H-Bridge motor driver, LIN transceiver and EEPROM. Also included are: header for expansion, eight LEDs, four potentiometers, three push buttons and a prototyping area. Included with the kit is a PIC16F627A and a PIC18F1320. Tutorial firmware is included along with the User's Guide.

18.20 PICDEM 17 Demonstration Board

The PICDEM 17 demonstration board is an evaluation board that demonstrates the capabilities of several Microchip microcontrollers, including PIC17C752, PIC17C756A, PIC17C762 and PIC17C766. A programmed sample is included. The PRO MATE II device programmer, or the PICSTART Plus development programmer, can be used to reprogram the device for user tailored application development. The PICDEM 17 demonstration board supports program download and execution from external on-board Flash memory. A generous prototype area is available for user hardware expansion.

18.21 PICDEM 18R PIC18C601/801 Demonstration Board

The PICDEM 18R demonstration board serves to assist development of the PIC18C601/801 family of Microchip microcontrollers. It provides hardware implementation of both 8-bit Multiplexed/Demultiplexed and 16-bit Memory modes. The board includes 2 Mb external Flash memory and 128 Kb SRAM memory, as well as serial EEPROM, allowing access to the wide range of memory types supported by the PIC18C601/801.

18.22 PICDEM LIN PIC16C43X Demonstration Board

The powerful LIN hardware and software kit includes a series of boards and three PICmicro microcontrollers. The small footprint PIC16C432 and PIC16C433 are used as slaves in the LIN communication and feature on-board LIN transceivers. A PIC16F874 Flash microcontroller serves as the master. All three microcontrollers are programmed with firmware to provide LIN bus communication.

18.23 PICkit™ 1 Flash Starter Kit

A complete “development system in a box”, the PICkit Flash Starter Kit includes a convenient multi-section board for programming, evaluation and development of 8/14-pin Flash PIC® microcontrollers. Powered via USB, the board operates under a simple Windows GUI. The PICkit 1 Starter Kit includes the User’s Guide (on CD ROM), PICkit 1 tutorial software and code for various applications. Also included are MPLAB® IDE (Integrated Development Environment) software, software and hardware “Tips ‘n Tricks for 8-pin Flash PIC® Microcontrollers” Handbook and a USB interface cable. Supports all current 8/14-pin Flash PIC microcontrollers, as well as many future planned devices.

18.24 PICDEM USB PIC16C7X5 Demonstration Board

The PICDEM USB Demonstration Board shows off the capabilities of the PIC16C745 and PIC16C765 USB microcontrollers. This board provides the basis for future USB products.

18.25 Evaluation and Programming Tools

In addition to the PICDEM series of circuits, Microchip has a line of evaluation kits and demonstration software for these products.

- KEELOQ evaluation and programming tools for Microchip’s HCS Secure Data Products
- CAN developers kit for automotive network applications
- Analog design boards and filter design software
- PowerSmart battery charging evaluation/calibration kits
- IrDA® development kit
- microID development and rLab™ development software
- SEEVAL® designer kit for memory evaluation and endurance calculations
- PICDEM MSC demo boards for Switching mode power supply, high-power IR driver, delta sigma ADC and flow rate sensor

Check the Microchip web page and the latest Product Selector Guide for the complete list of demonstration and evaluation kits.

PIC16F917/916/914/913

NOTES:

19.0 ELECTRICAL SPECIFICATIONS

Absolute Maximum Ratings^(†)

Ambient temperature under bias	-40° to +125°C
Storage temperature	-65°C to +150°C
Voltage on VDD with respect to VSS	-0.3V to +6.5V
Voltage on $\overline{\text{MCLR}}$ with respect to VSS	-0.3V to +13.5V
Voltage on all other pins with respect to VSS	-0.3V to (VDD + 0.3V)
Total power dissipation ⁽¹⁾	800 mW
Maximum current out of VSS pin	300 mA
Maximum current into VDD pin	250 mA
Input clamp current, I _{IK} (V _I < 0 or V _I > VDD)	±20 mA
Output clamp current, I _{OK} (V _O < 0 or V _O > VDD)	±20 mA
Maximum output current sunk by any I/O pin	25 mA
Maximum output current sourced by any I/O pin	25 mA
Maximum current sourced by all ports (combined)	200 mA
Maximum current sunk by by all ports (combined)	200 mA

- Note 1:** Power dissipation is calculated as follows: $P_{DIS} = V_{DD} \times \{I_{DD} - \sum I_{OH}\} + \sum \{(V_{DD} - V_{OH}) \times I_{OH}\} + \sum (V_{OL} \times I_{OL})$.
- 2:** PORTD and PORTE are not implemented in PIC16F913/916 devices.

† NOTICE: Stresses above those listed under "Absolute Maximum Ratings" may cause permanent damage to the device. This is a stress rating only and functional operation of the device at those or any other conditions above those indicated in the operation listings of this specification is not implied. Exposure to maximum rating conditions for extended periods may affect device reliability.

Note: Voltage spikes below VSS at the MCLR pin, inducing currents greater than 80 mA, may cause latch-up. Thus, a series resistor of 50-100 Ω should be used when applying a "low" level to the MCLR pin, rather than pulling this pin directly to VSS.

PIC16F917/916/914/913

FIGURE 19-1: PIC16F917/916/914/913 VOLTAGE-FREQUENCY GRAPH, $-40^{\circ}\text{C} \leq T_A \leq +125^{\circ}\text{C}$

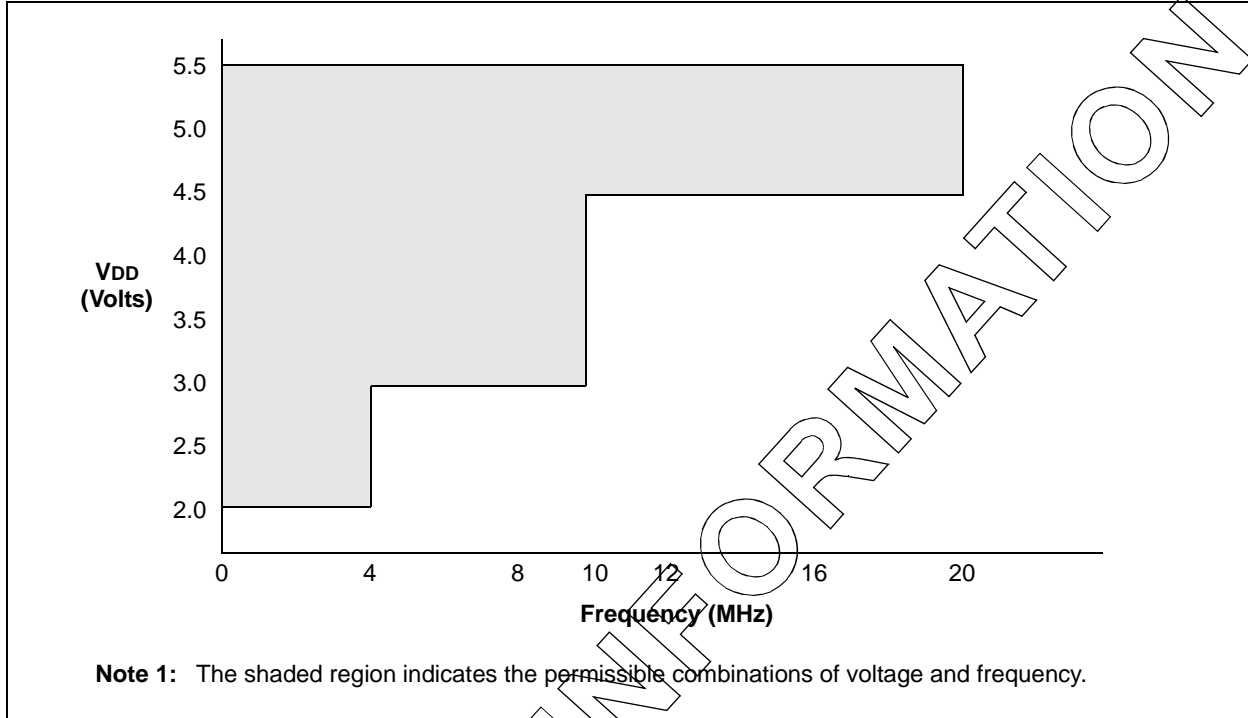

PIC16F917/916/914/913

19.1 DC Characteristics: PIC16F917/916/914/913-I (Industrial) PIC16F917/916/914/913-E (Extended)

DC CHARACTERISTICS		Standard Operating Conditions (unless otherwise stated) Operating temperature -40°C ≤ TA ≤ +85°C for industrial -40°C ≤ TA ≤ +125°C for extended					
Param No.	Sym	Characteristic	Min	Typ†	Max	Units	Conditions
D001 D001C D001D	VDD	Supply Voltage	2.0 3.0 4.5	—	5.5 5.5 5.5	V	FOSC ≤ 4 MHz: FOSC ≤ 10 MHz FOSC ≤ 20 MHz
D002	VDR	RAM Data Retention Voltage⁽¹⁾	1.5*	—	—	V	Device in Sleep mode
D003	VPOR	VDD Start Voltage to ensure internal Power-on Reset signal	—	VSS	—	V	See Section 16.3 “Power-on Reset” for details.
D004	SVDD	VDD Rise Rate to ensure internal Power-on Reset signal	0.05 *	—	—	V/ms	See Section 16.3 “Power-on Reset” for details.
D005	VBOR	Brown-out Reset	—	2.1	—	V	

* These parameters are characterized but not tested.

† Data in “Typ” column is at 5.0V, 25°C unless otherwise stated. These parameters are for design guidance only and are not tested.

Note 1: This is the limit to which VDD can be lowered in Sleep mode without losing RAM data.

PIC16F917/916/914/913

19.2 DC Characteristics: PIC16F917/916/914/913-I (Industrial)

DC CHARACTERISTICS		Standard Operating Conditions (unless otherwise stated) Operating temperature $-40^{\circ}\text{C} \leq T_A \leq +85^{\circ}\text{C}$ for industrial					
Param No.	Device Characteristics	Min	Typ†	Max	Units	Conditions	
						VDD	Note
D010	Supply Current (IDD) ^(1, 2)	—	8	TBD	μA	2.0	Fosc = 32 kHz LP Oscillator mode
		—	11	TBD	μA	3.0	
		—	33	TBD	μA	5.0	
D011		—	110	TBD	μA	2.0	Fosc = 1 MHz XT Oscillator mode
		—	190	TBD	μA	3.0	
		—	330	TBD	μA	5.0	
D012		—	220	TBD	μA	2.0	Fosc = 4 MHz XT Oscillator mode
		—	370	TBD	μA	3.0	
		—	0.6	TBD	mA	5.0	
D013		—	70	TBD	μA	2.0	Fosc = 1 MHz EC Oscillator mode
		—	140	TBD	μA	3.0	
		—	260	TBD	μA	5.0	
D014		—	180	TBD	μA	2.0	Fosc = 4 MHz EC Oscillator mode
		—	320	TBD	μA	3.0	
		—	500	TBD	μA	5.0	
D015		—	5	TBD	μA	2.0	Fosc = 31 kHz INTOSC mode
		—	14	TBD	μA	3.0	
		—	30	TBD	mA	5.0	
D016		—	340	TBD	μA	2.0	Fosc = 4 MHz INTOSC mode
		—	500	TBD	μA	3.0	
		—	0.8	TBD	mA	5.0	
D017		—	180	TBD	μA	2.0	Fosc = 4 MHz EXTRC mode
		—	320	TBD	μA	3.0	
		—	580	TBD	μA	5.0	
D018		—	2.1	TBD	mA	4.5	Fosc = 20 MHz HS Oscillator mode
		—	3.0	TBD	mA	5.0	

Legend: TBD = To Be Determined

† Data in 'Typ' column is at 5.0V, 25°C unless otherwise stated. These parameters are for design guidance only and are not tested.

Note 1: The test conditions for all IDD measurements in active Operation mode are: OSC1 = external square wave, from rail-to-rail; all I/O pins tri-stated, pulled to VDD; MCLR = VDD; WDT disabled.

- 2: The supply current is mainly a function of the operating voltage and frequency. Other factors, such as I/O pin loading and switching rate, oscillator type, internal code execution pattern and temperature, also have an impact on the current consumption.
- 3: The peripheral current is the sum of the base IDD or IPD and the additional current consumed when this peripheral is enabled. The peripheral Δ current can be determined by subtracting the base IDD or IPD current from this limit. Max values should be used when calculating total current consumption.
- 4: The power-down current in Sleep mode does not depend on the oscillator type. Power-down current is measured with the part in Sleep mode, with all I/O pins in high-impedance state and tied to VDD.

PIC16F917/916/914/913

19.2 DC Characteristics: PIC16F917/916/914/913-I (Industrial) (Continued)

DC CHARACTERISTICS		Standard Operating Conditions (unless otherwise stated) Operating temperature $-40^{\circ}\text{C} \leq T_A \leq +85^{\circ}\text{C}$ for industrial					
Param No.	Device Characteristics	Min	Typ†	Max	Units	Conditions	
						VDD	Note
D020	Power-down Base Current (IPD) ⁽⁴⁾	—	0.1	TBD	μA	2.0	WDT, BOR, Comparators, VREF and T1OSC disabled
		—	0.5	TBD	μA	3.0	
		—	0.75	TBD	μA	5.0	
D021		—	0.6	TBD	μA	2.0	WDT Current
		—	1.8	TBD	μA	3.0	
		—	8.4	TBD	μA	5.0	
D022		—	58	TBD	μA	3.0	BOR Current
		—	75	TBD	μA	5.0	
D023		—	35	TBD	μA	2.0	Comparator Current ⁽³⁾
		—	65	TBD	μA	3.0	
		—	130	TBD	μA	5.0	
D024		—	40	TBD	μA	2.0	CVREF Current
		—	50.5	TBD	μA	3.0	
		—	80	TBD	μA	5.0	
D025		—	2.1	TBD	μA	2.0	T1OSC Current
		—	2.5	TBD	μA	3.0	
		—	3.4	TBD	μA	5.0	
D026		—	1.2	TBD	nA	3.0	A/D Current
		—	0.0022	TBD	μA	5.0	

Legend: TBD = To Be Determined

† Data in 'Typ' column is at 5.0V, 25°C unless otherwise stated. These parameters are for design guidance only and are not tested.

- Note 1:** The test conditions for all IDD measurements in active Operation mode are: OSC1 = external square wave, from rail-to-rail; all I/O pins tri-stated, pulled to VDD; MCLR = VDD; WDT disabled.
- 2:** The supply current is mainly a function of the operating voltage and frequency. Other factors, such as I/O pin loading and switching rate, oscillator type, internal code execution pattern and temperature, also have an impact on the current consumption.
- 3:** The peripheral current is the sum of the base IDD or IPD and the additional current consumed when this peripheral is enabled. The peripheral Δ current can be determined by subtracting the base IDD or IPD current from this limit. Max values should be used when calculating total current consumption.
- 4:** The power-down current in Sleep mode does not depend on the oscillator type. Power-down current is measured with the part in Sleep mode, with all I/O pins in high-impedance state and tied to VDD.

PIC16F917/916/914/913

19.3 DC Characteristics: PIC16F917/916/914/913-E (Extended)

DC CHARACTERISTICS		Standard Operating Conditions (unless otherwise stated) Operating temperature $-40^{\circ}\text{C} \leq T_A \leq +125^{\circ}\text{C}$ for extended					Conditions	
Param No.	Device Characteristics	Min	Typ†	Max	Units	Conditions		
						VDD	Note	
D010E	Supply Current (IDD) ^(1, 2)	—	8	TBD	μA	2.0	FOSC = 32 kHz LP Oscillator mode	
		—	11	TBD	μA	3.0		
		—	33	TBD	μA	5.0		
D011E		—	110	TBD	μA	2.0	FOSC = 1 MHz XT Oscillator mode	
		—	190	TBD	μA	3.0		
		—	330	TBD	μA	5.0		
D012E		—	220	TBD	μA	2.0	FOSC = 4 MHz XT Oscillator mode	
		—	370	TBD	μA	3.0		
		—	0.6	TBD	mA	5.0		
D013E		—	70	TBD	μA	2.0	FOSC = 1 MHz EC Oscillator mode	
		—	140	TBD	μA	3.0		
		—	260	TBD	μA	5.0		
D014E		—	180	TBD	μA	2.0	FOSC = 4 MHz EC Oscillator mode	
		—	320	TBD	μA	3.0		
		—	500	TBD	μA	5.0		
D015E		—	5	TBD	μA	2.0	FOSC = 31 kHz INTOSC mode	
		—	14	TBD	μA	3.0		
		—	30	TBD	mA	5.0		
D016E		—	340	TBD	μA	2.0	FOSC = 4 MHz INTOSC mode	
		—	500	TBD	μA	3.0		
		—	0.8	TBD	mA	5.0		
D017E		—	180	TBD	μA	2.0	FOSC = 4 MHz EXTRC mode	
		—	320	TBD	μA	3.0		
		—	580	TBD	μA	5.0		
D018E		—	2.1	TBD	mA	4.5	FOSC = 20 MHz HS Oscillator mode	
		—	3.0	TBD	mA	5.0		

Legend: TBD = To Be Determined

† Data in 'Typ' column is at 5.0V, 25°C unless otherwise stated. These parameters are for design guidance only and are not tested.

- Note 1:** The test conditions for all IDD measurements in active Operation mode are: OSC1 = external square wave, from rail-to-rail; all I/O pins tri-stated, pulled to VDD; MCLR = VDD; WDT disabled.
- 2:** The supply current is mainly a function of the operating voltage and frequency. Other factors, such as I/O pin loading and switching rate, oscillator type, internal code execution pattern and temperature, also have an impact on the current consumption.
- 3:** The peripheral current is the sum of the base IDD or IPD and the additional current consumed when this peripheral is enabled. The peripheral Δ current can be determined by subtracting the base IDD or IPD current from this limit. Max values should be used when calculating total current consumption.
- 4:** The power-down current in Sleep mode does not depend on the oscillator type. Power-down current is measured with the part in Sleep mode, with all I/O pins in high-impedance state and tied to VDD.

PIC16F917/916/914/913

19.3 DC Characteristics: PIC16F917/916/914/913-E (Extended) (Continued)

DC CHARACTERISTICS		Standard Operating Conditions (unless otherwise stated) Operating temperature $-40^{\circ}\text{C} \leq T_A \leq +125^{\circ}\text{C}$ for extended					
Param No.	Device Characteristics	Min	Typ†	Max	Units	Conditions	
						VDD	Note
D020E	Power-down Base Current (IPD) ⁽⁴⁾	—	0.1	TBD	μA	2.0	WDT, BOR, Comparators, VREF and T1OSC disabled
		—	0.5	TBD	μA	3.0	
		—	0.75	TBD	μA	5.0	
D021E		—	0.6	TBD	μA	2.0	WDT Current
		—	1.8	TBD	μA	3.0	
		—	8.4	TBD	μA	5.0	
D022E		—	58	TBD	μA	3.0	BOR Current
		—	75	TBD	μA	5.0	
D023E		—	35	TBD	μA	2.0	Comparator Current ⁽³⁾
		—	65	TBD	μA	3.0	
		—	130	TBD	μA	5.0	
D024E		—	40	TBD	μA	2.0	CVREF Current
		—	50.5	TBD	μA	3.0	
		—	80	TBD	μA	5.0	
D025E		—	2.1	TBD	μA	2.0	T1OSC Current
		—	2.5	TBD	μA	3.0	
		—	3.4	TBD	μA	5.0	
D026E		—	1.2	TBD	μA	3.0	A/D Current ⁽³⁾
		—	0.0022	TBD	μA	5.0	

Legend: TBD = To Be Determined

† Data in 'Typ' column is at 5.0V, 25°C unless otherwise stated. These parameters are for design guidance only and are not tested.

- Note 1:** The test conditions for all IDD measurements in active Operation mode are: OSC1 = external square wave, from rail-to-rail; all I/O pins tri-stated, pulled to VDD; MCLR = VDD; WDT disabled.
- 2:** The supply current is mainly a function of the operating voltage and frequency. Other factors, such as I/O pin loading and switching rate, oscillator type, internal code execution pattern and temperature, also have an impact on the current consumption.
- 3:** The peripheral current is the sum of the base IDD or IPD and the additional current consumed when this peripheral is enabled. The peripheral Δ current can be determined by subtracting the base IDD or IPD current from this limit. Max values should be used when calculating total current consumption.
- 4:** The power-down current in Sleep mode does not depend on the oscillator type. Power-down current is measured with the part in Sleep mode, with all I/O pins in high-impedance state and tied to VDD.

PIC16F917/916/914/913

19.4 DC Characteristics: PIC16F917/916/914/913-I (Industrial) PIC16F917/916/914/913-E (Extended)

DC CHARACTERISTICS			Standard Operating Conditions (unless otherwise stated) Operating temperature $-40^{\circ}\text{C} \leq T_A \leq +85^{\circ}\text{C}$ for industrial $-40^{\circ}\text{C} \leq T_A \leq +125^{\circ}\text{C}$ for extended				
Param No.	Sym	Characteristic	Min	Typ†	Max	Units	Conditions
D030 D030A D031 D032 D033 D033A	V _{IL}	Input Low Voltage I/O port: with TTL buffer with Schmitt Trigger buffer MCLR, OSC1 (RC mode) OSC1 (XT and LP modes) ⁽¹⁾ OSC1 (HS mode) ⁽¹⁾	V _{SS} V _{SS} V _{SS} V _{SS} V _{SS} V _{SS}	— — — — — —	0.8 0.15 V _{DD} 0.2 V _{DD} 0.2 V _{DD} 0.3 0.3 V _{DD}	V V V V V V	$4.5\text{V} \leq V_{DD} \leq 5.5\text{V}$ Otherwise Entire range
D034		I ² C™ mode	V _{SS}	—	0.3 V _{DD}	V	Entire V _{DD} Range
D040 D040A D041 D042 D043 D043A D043B	V _{IH}	Input High Voltage I/O port: with TTL buffer with Schmitt Trigger buffer MCLR OSC1 (XT and LP modes) OSC1 (HS mode) OSC1 (RC mode)	2.0 (0.25 V _{DD} + 0.8) 0.8 V _{DD} 0.8 V _{DD} 1.6 0.7 V _{DD} 0.9 V _{DD}	— — — — — — —	V _{DD} V _{DD} V _{DD} V _{DD} V _{DD} V _{DD} V _{DD}	V V V V V V V	$4.5\text{V} \leq V_{DD} \leq 5.5\text{V}$ Otherwise Entire range (Note 1) (Note 1)
D044		I ² C mode	0.7 V _{DD}	—	V _{DD}	V	Entire V _{DD} Range
D070	IPUR	PORTB Weak Pull-up Current	50*	250	400*	μA	V _{DD} = 5.0V, V _{PIN} = V _{SS}
D060 D061 D063	I _{IL}	Input Leakage Current ⁽²⁾ I/O port MCLR ⁽³⁾ OSC1	— — —	± 0.1 ± 0.1 ± 0.1	± 1 ± 5 ± 5	μA μA μA	V _{SS} ≤ V _{PIN} ≤ V _{DD} , Pin at high-impedance V _{SS} ≤ V _{PIN} ≤ V _{DD} V _{SS} ≤ V _{PIN} ≤ V _{DD} , XT, HS and LP OSC configuration
D080 D083	V _{OL}	Output Low Voltage I/O port OSC2/CLKO (RC mode)	— —	— —	0.6 0.6	V V	I _{OL} = 8.5 mA, V _{DD} = 4.5V (Ind.) I _{OL} = 1.6 mA, V _{DD} = 4.5V (Ind.) I _{OL} = 1.2 mA, V _{DD} = 4.5V (Ext.)
D090 D092	V _{OH}	Output High Voltage I/O port OSC2/CLKO (RC mode)	V _{DD} - 0.7 V _{DD} - 0.7	— —	— —	V V	I _{OH} = -3.0 mA, V _{DD} = 4.5V (Ind.) I _{OH} = -1.3 mA, V _{DD} = 4.5V (Ind.) I _{OH} = -1.0 mA, V _{DD} = 4.5V (Ext.)

* These parameters are characterized but not tested.

† Data in 'Typ' column is at 5.0V, 25°C unless otherwise stated. These parameters are for design guidance only and are not tested.

Note 1: In RC oscillator configuration, the OSC1/CLKI pin is a Schmitt Trigger input. It is not recommended to use an external clock in RC mode.

2: Negative current is defined as current sourced by the pin.

3: The leakage current on the MCLR pin is strongly dependent on the applied voltage level. The specified levels represent normal operating conditions. Higher leakage current may be measured at different input voltages.

PIC16F917/916/914/913

19.4 DC Characteristics: PIC16F917/916/914/913-I (Industrial) PIC16F917/916/914/913-E (Extended) (Continued)

DC CHARACTERISTICS			Standard Operating Conditions (unless otherwise stated) Operating temperature -40°C ≤ TA ≤ +85°C for industrial -40°C ≤ TA ≤ +125°C for extended				
Param No.	Sym	Characteristic	Min	Typ†	Max	Units	Conditions
Capacitive Loading Specs on Output Pins							
D100	COS C2	OSC2 pin	—	—	15*	pF	In XT, HS and LP modes when external clock is used to drive OSC1
D101	Cio	All I/O pins	—	—	50*	pF	
Data EEPROM Memory							
D120	Ed	Byte Endurance	100K	1M	—	E/W	-40°C ≤ TA ≤ +85°C
D120A	Ed	Byte Endurance	10K	100K	—	E/W	+85°C ≤ TA ≤ +125°C
D121	VDRW	VDD for Read/Write	VMIN	—	5.5	V	Using EECON1 to read/write VMIN = Minimum operating voltage
D122	TDEW	Erase/Write Cycle Time	—	5	6	ms	
D123	TRETD	Characteristic Retention	40	—	—	Year	Provided no other specifications are violated
D124	TREF	Number of Total Erase/Write Cycles before Refresh ⁽²⁾	1M	10M	—	E/W	-40°C ≤ TA ≤ +85°C
Program Flash Memory							
D130	EP	Cell Endurance	10K	100K	—	E/W	-40°C ≤ TA ≤ +85°C
D130A	Ed	Cell Endurance	1K	10K	—	E/W	+85°C ≤ TA ≤ +125°C
D131	VPR	VDD for Read	VMIN	—	5.5	V	VMIN = Minimum operating voltage
D132	VPEW	VDD for Erase/Write	4.5	—	5.5	V	
D133	TPEW	Erase/Write cycle time	—	2	2.5	ms	
D134	TRETD	Characteristic Retention	40	—	—	Year	Provided no other specifications are violated

* These parameters are characterized but not tested.

† Data in 'Typ' column is at 5.0V, 25°C unless otherwise stated. These parameters are for design guidance only and are not tested.

Note 1: In RC oscillator configuration, the OSC1/CLKI pin is a Schmitt Trigger input. It is not recommended to use an external clock in RC mode.

2: Negative current is defined as current sourced by the pin.

3: The leakage current on the MCLR pin is strongly dependent on the applied voltage level. The specified levels represent normal operating conditions. Higher leakage current may be measured at different input voltages.

PIC16F917/916/914/913

19.5 Timing Parameter Symbology

The timing parameter symbols have been created with one of the following formats:

1. TppS2ppS
2. TppS

T

F Frequency

T Time

Lowercase letters (pp) and their meanings:

pp

cc CCP1

osc OSC1

ck CLKO

rd \overline{RD}

cs \overline{CS}

rw \overline{RD} or \overline{WR}

di SDI

sc SCK

do SDO

ss \overline{SS}

dt Data in

t0 T0CKI

io I/O port

t1 T1CKI

mc \overline{MCLR}

wr \overline{WR}

Uppercase letters and their meanings:

S

F Fall

P Period

H High

R Rise

I Invalid (High-impedance)

V Valid

L Low

Z High-impedance

FIGURE 19-2: LOAD CONDITIONS

19.6 AC Characteristics: PIC16F917/916/914/913 (Industrial, Extended)

FIGURE 19-3: EXTERNAL CLOCK TIMING

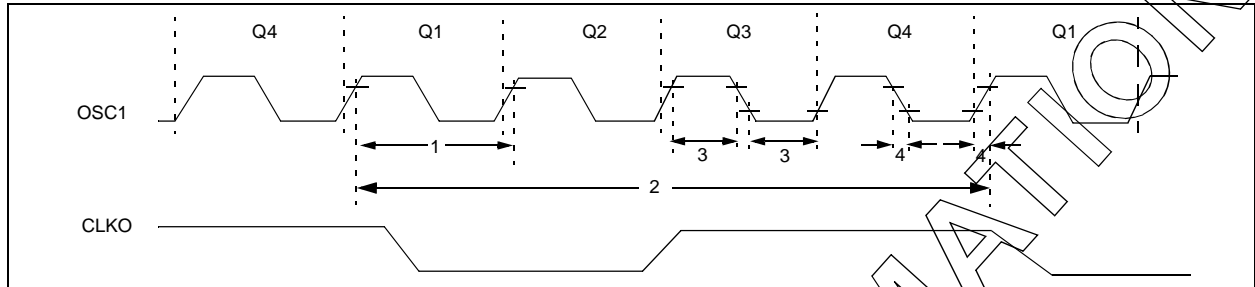

TABLE 19-1: EXTERNAL CLOCK TIMING REQUIREMENTS

Standard Operating Conditions (unless otherwise stated)										
		Operating Temperature $-40^{\circ}\text{C} \leq T_A \leq +125^{\circ}\text{C}$								
Param No.	Sym	Characteristic	Min	Typ†	Max	Units	Conditions			
	Fosc	External CLKI Frequency ⁽¹⁾	DC	—	37	kHz	LP Oscillator mode			
			DC	—	4	MHz	XT Oscillator mode			
			DC	—	20	MHz	HS Oscillator mode			
			DC	—	20	MHz	EC Oscillator mode			
	Oscillator Frequency ⁽¹⁾	5	—	37	kHz	LP Oscillator mode				
		—	4	—	MHz	INTOSC mode				
		DC	—	4	MHz	RC Oscillator mode				
		0.1	—	4	MHz	XT Oscillator mode				
1	Tosc	External CLKI Period ⁽¹⁾	27	—	∞	μs	LP Oscillator mode			
			50	—	∞	ns	HS Oscillator mode			
			50	—	∞	ns	EC Oscillator mode			
			250	—	∞	ns	XT Oscillator mode			
	Oscillator Period ⁽¹⁾	27	—	200	μs	LP Oscillator mode				
		—	250	—	ns	INTOSC mode				
2	Tcy	Instruction Cycle Time ⁽¹⁾	200	Tcy	DC	ns	Tcy = 4/Fosc			
			3	TosL, TosH	External CLKI (OSC1) High	2*	—	—	μs	LP oscillator, TOSC L/H duty cycle
						20*	—	—	ns	HS oscillator, TOSC L/H duty cycle
			External CLKI Low	100*	—	—	ns	XT oscillator, TOSC L/H duty cycle		
4	TosR, TosF	External CLKI Rise		—	—	50*	ns	LP oscillator		
			External CLKI Fall	—	—	25*	ns	XT oscillator		
				—	—	15*	ns	HS oscillator		

* These parameters are characterized but not tested.

† Data in 'Typ' column is at 5V, 25°C unless otherwise stated. These parameters are for design guidance only and are not tested.

Note 1: Instruction cycle period (Tcy) equals four times the input oscillator time base period. All specified values are based on characterization data for that particular oscillator type under standard operating conditions with the device executing code. Exceeding these specified limits may result in an unstable oscillator operation and/or higher than expected current consumption. All devices are tested to operate at 'min' values with an external clock applied to OSC1 pin. When an external clock input is used, the 'max' cycle time limit is 'DC' (no clock) for all devices.

PIC16F917/916/914/913

TABLE 19-2: PRECISION INTERNAL OSCILLATOR PARAMETERS

Standard Operating Conditions (unless otherwise stated)								
Operating Temperature $-40^{\circ}\text{C} \leq T_A \leq +125^{\circ}\text{C}$								
Param No.	Sym	Characteristic	Freq. Tolerance	Min	Typ†	Max	Units	Conditions
F10	FOSC	Internal Calibrated INTOSC Frequency ⁽¹⁾	$\pm 1\%$	—	8.00	TBD	MHz	V_{DD} and Temperature TBD
			$\pm 2\%$	—	8.00	TBD	MHz	$2.5\text{V} \leq V_{DD} \leq 5.5\text{V}$ $0^{\circ}\text{C} \leq T_A \leq +85^{\circ}\text{C}$
			$\pm 5\%$	—	8.00	TBD	MHz	$2.0\text{V} \leq V_{DD} \leq 5.5\text{V}$ $-40^{\circ}\text{C} \leq T_A \leq +85^{\circ}\text{C}$ (Ind.) $-40^{\circ}\text{C} \leq T_A \leq +125^{\circ}\text{C}$ (Ext.)
F14	TIOSC ST	Oscillator Wake-up from Sleep Start-up Time*	—	—	TBD	TBD	μs	$V_{DD} = 2.0\text{V}$, -40°C to $+85^{\circ}\text{C}$
			—	—	TBD	TBD	μs	$V_{DD} = 3.0\text{V}$, -40°C to $+85^{\circ}\text{C}$
			—	—	TBD	TBD	μs	$V_{DD} = 5.0\text{V}$, -40°C to $+85^{\circ}\text{C}$

Legend: TBD = To Be Determined

* These parameters are characterized but not tested.

† Data in 'Typ' column is at 5.0V, 25°C unless otherwise stated. These parameters are for design guidance only and are not tested.

Note 1: To ensure these oscillator frequency tolerances, V_{DD} and V_{SS} must be capacitively decoupled as close to the device as possible. 0.1 μF and 0.01 μF values in parallel are recommended.

ons

PIC16F917/916/914/913

FIGURE 19-5: RESET, WATCHDOG TIMER, OSCILLATOR START-UP TIMER AND POWER-UP TIMER TIMING

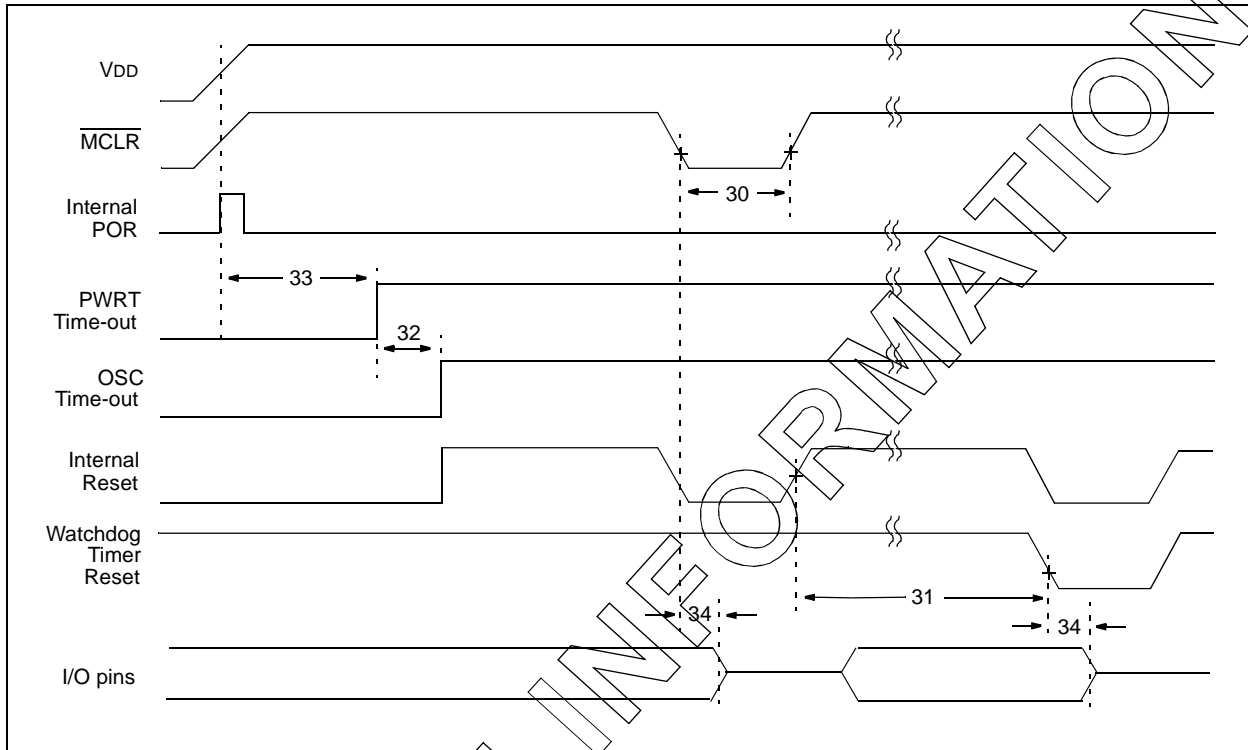

FIGURE 19-6: BROWN-OUT RESET TIMING AND CHARACTERISTICS

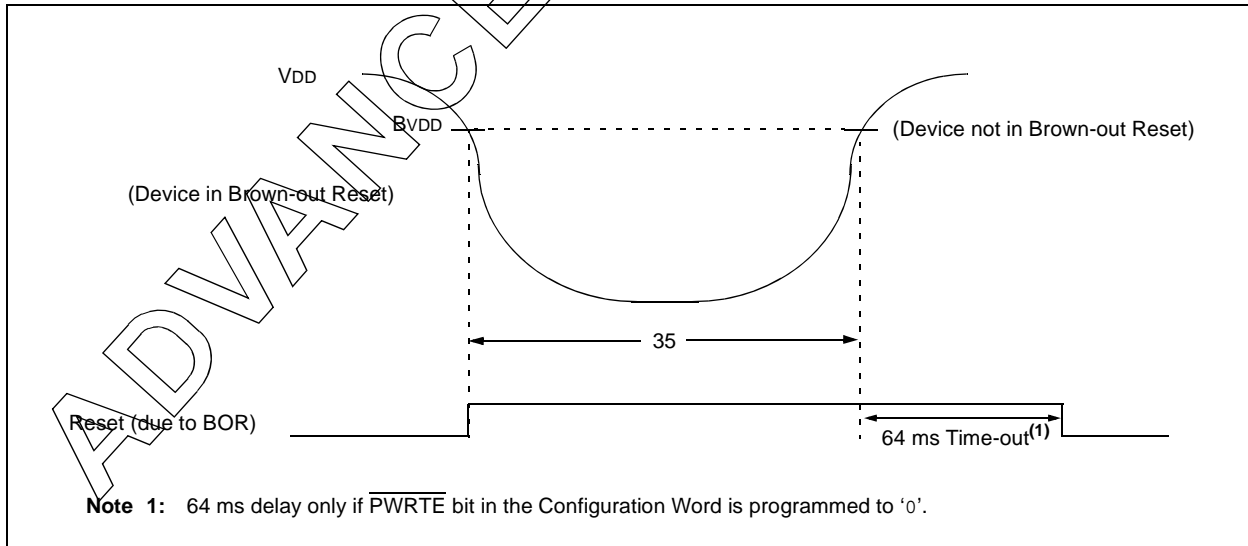

TABLE 19-4: RESET, WATCHDOG TIMER, OSCILLATOR START-UP TIMER, POWER-UP TIMER AND BROWN-OUT RESET REQUIREMENTS

Standard Operating Conditions (unless otherwise stated)							
Operating Temperature $-40^{\circ}\text{C} \leq T_A \leq +125^{\circ}\text{C}$							
Param No.	Sym	Characteristic	Min	Typ†	Max	Units	Conditions
30	TMCL	MCLR Pulse Width (low)	2 11	— 18	— 24	μs ms	$V_{DD} = 5\text{V}$, -40°C to $+85^{\circ}\text{C}$ Extended temperature
31	TWDT	Watchdog Timer Time-out Period (No Prescaler)	10 10	17 17	25 30	ms ms	$V_{DD} = 5\text{V}$, -40°C to $+85^{\circ}\text{C}$ Extended temperature
32	TOST	Oscillation Start-up Timer Period	—	1024 TOSC	—	—	TOSC = OSC1 period
33*	TPWRT	Power-up Timer Period	28* TBD	64 TBD	132* TBD	ms ms	$V_{DD} = 5\text{V}$, -40°C to $+85^{\circ}\text{C}$ Extended Temperature
34	TIOZ	I/O High-impedance from MCLR Low or Watchdog Timer Reset	—	—	2.0	μs	
	BVDD	Brown-out Reset Voltage	2.025	—	2.175	V	
35	TBOR	Brown-out Reset Pulse Width	100*	—	—	μs	$V_{DD} \leq BVDD$ (D005)

Legend: TBD = To Be Determined

* These parameters are characterized but not tested.

† Data in 'Typ' column is at 5V, 25°C unless otherwise stated. These parameters are for design guidance only and are not tested.

FIGURE 19-7: TIMER0 AND TIMER1 EXTERNAL CLOCK TIMINGS

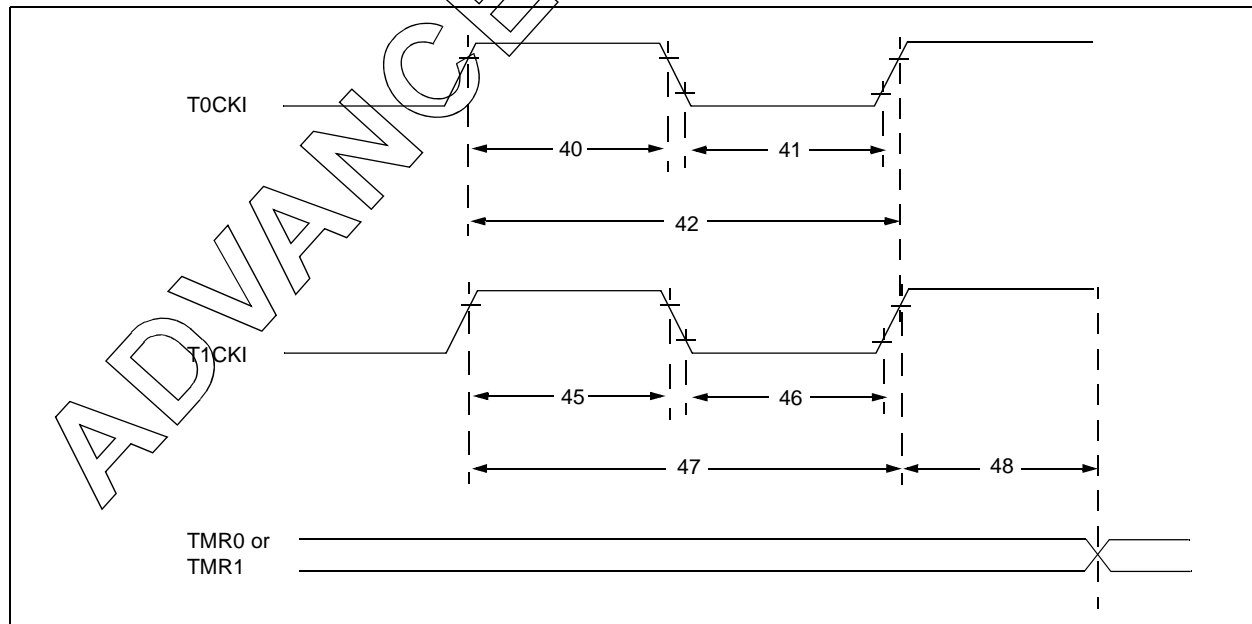

PIC16F917/916/914/913

TABLE 19-5: TIMER0 AND TIMER1 EXTERNAL CLOCK REQUIREMENTS

Param No.	Sym	Characteristic		Min	Typ†	Max	Units	Conditions	
40*	T _{T0H}	T0CKI High Pulse Width	No Prescaler	0.5 T _{CY} + 20	—	—	ns		
			With Prescaler	10	—	—	ns		
41*	T _{T0L}	T0CKI Low Pulse Width	No Prescaler	0.5 T _{CY} + 20	—	—	ns		
			With Prescaler	10	—	—	ns		
42*	T _{T0P}	T0CKI Period		Greater of: 20 or $\frac{T_{CY} + 40}{N}$	—	—	ns	N = prescale value (2, 4, ..., 256)	
45*	T _{T1H}	T1CKI High Time	Synchronous, No Prescaler	0.5 T _{CY} + 20	—	—	ns		
			Synchronous, with Prescaler	3.0-5.5V	15	—	—		ns
				2.0-5.5V	25	—	—		ns
			Asynchronous	3.0-5.5V	30	—	—		ns
2.0-5.5V	50	—		—	ns				
46*	T _{T1L}	T1CKI Low Time	Synchronous, No Prescaler	0.5 T _{CY} + 20	—	—	ns		
			Synchronous, with Prescaler	3.0-5.5V	15	—	—		ns
				2.0-5.5V	25	—	—		ns
			Asynchronous	3.0-5.5V	30	—	—		ns
2.0-5.5V	50	—		—	ns				
47*	T _{T1P}	T1CKI Input Period	Synchronous	3.0-5.5V	Greater of: 30 or $\frac{T_{CY} + 40}{N}$	—	—	ns	N = prescale value (1, 2, 4, 8)
				2.0-5.5V	50 or $\frac{T_{CY} + 40}{N}$	—	—		
			Asynchronous	3.0-5.5V	60	—	—	ns	
				2.0-5.5V	100	—	—	ns	
	F _{T1}	Timer1 oscillator input frequency range (oscillator enabled by setting bit T1OSCEN)		DC	—	37*	kHz		
48	TCKEZTMR1	Delay from external clock edge to timer increment		2 T _{osc} *	—	7 T _{osc} *	—		

* These parameters are characterized but not tested.

† Data in 'Typ' column is at 5V, 25°C unless otherwise stated. These parameters are for design guidance only and are not tested.

FIGURE 19-8: USART SYNCHRONOUS TRANSMISSION (MASTER/SLAVE) TIMING

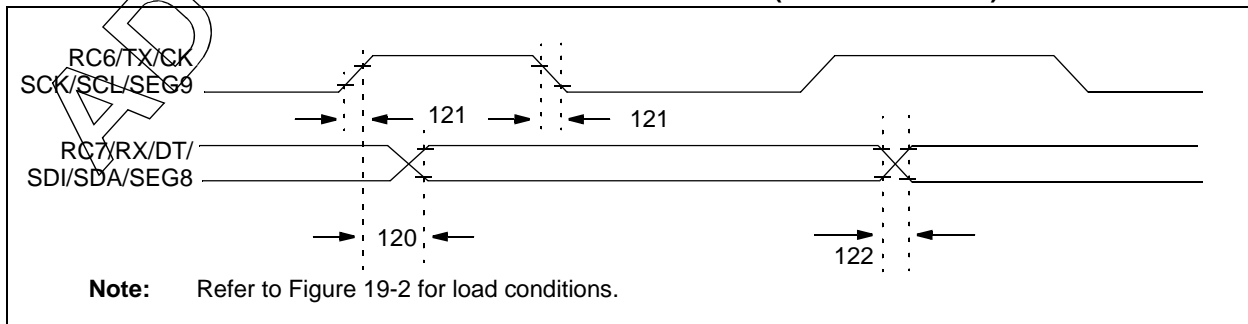

121	TCKRF	Clock out rise time and fall time (Master mode)	3.0-5.5V	—	45	ns
			2.0-5.5V	—	50	ns
122	TDTRF	Data-out rise time and fall time	3.0-5.5V	—	45	ns
			2.0-5.5V	—	50	ns

FIGURE 19-9: USART SYNCHRONOUS RECEIVE (MASTER/SLAVE) TIMING

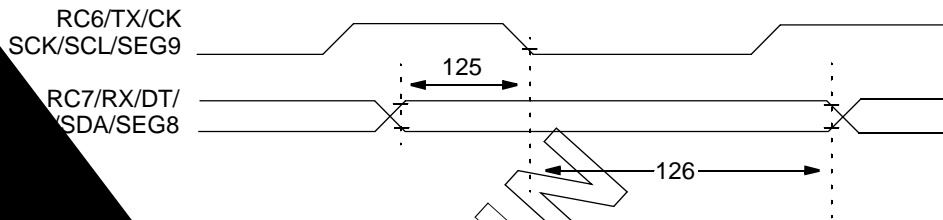

Refer to Figure 19-2 for load conditions.

USART SYNCHRONOUS RECEIVE REQUIREMENTS

Conditions (unless otherwise stated)
 $-40^{\circ}\text{C} \leq T_A \leq +125^{\circ}\text{C}$

Characteristic	Min	Max	Units
(Master and Slave)			
CK ↓ (DT hold time)	10	—	ns
(DT hold time)	15	—	ns

PWM TIMINGS

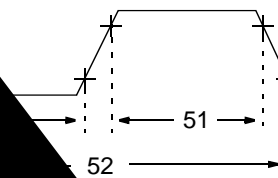

PIC16F917/916/914/913

TABLE 19-8: CAPTURE/COMPARE/PWM REQUIREMENTS

Param. No.	Sym	Characteristic		Min	Typ†	Max	Units	Conditions	
50*	TccL	CCP1 input low time	No Prescaler	0.5T _{CY} + 5	—	—	ns		
			With Prescaler	3.0-5.5V	10	—	—		ns
				2.0-5.5V	20	—	—		ns
51*	TccH	CCP1 input high time	No Prescaler	0.5T _{CY} + 5	—	—	ns		
			With Prescaler	3.0-5.5V	10	—	—		ns
				2.0-5.5V	20	—	—		ns
52*	TccP	CCP1 input period		$\frac{3T_{CY} + 40}{N}$	—	—	ns	N = prescale value (1,4 or 16)	
53*	TccR	CCP1 output fall time	3.0-5.5V	—	10	25	ns		
			2.0-5.5V	—	25	50	ns		
54*	TccF	CCP1 output fall time	3.0-5.5V	—	10	25	ns		
			2.0-5.5V	—	25	45	ns		

* These parameters are characterized but not tested.

† Data in "Typ" column is at 5.0V, 25°C unless otherwise stated. Parameters are for design guidance only and are not tested.

TABLE 19-9: COMPARATOR SPECIFICATIONS

Comparator Specifications		Standard Operating Conditions (unless otherwise stated) Operating temperature -40°C ≤ T _A ≤ +125°C				
Sym	Characteristics	Min	Typ	Max	Units	Comments
VOS	Input Offset Voltage	—	±5.0	±10	mV	
VCM	Input Common Mode Voltage	0	—	V _{DD} - 1.5	V	
CMRR	Common Mode Rejection Ratio	+55*	—	—	db	
TRT	Response Time ⁽¹⁾	—	150	400*	ns	
TMC2COV	Comparator Mode Change to Output Valid	—	—	10*	µs	

* These parameters are characterized but not tested.

Note 1: Response time measured with one comparator input at (V_{DD} - 1.5)/2 while the other input transitions from V_{SS} to V_{DD} - 1.5V.

TABLE 19-10: COMPARATOR VOLTAGE REFERENCE SPECIFICATIONS

Voltage Reference Specifications		Standard Operating Conditions (unless otherwise stated) Operating temperature -40°C ≤ T _A ≤ +125°C				
Sym.	Characteristics	Min	Typ	Max	Units	Comments
	Resolution	—	V _{DD} /24*	—	LSb	Low Range (VRR = 1)
		—	V _{DD} /32	—	LSb	High Range (VRR = 0)
	Absolute Accuracy	—	—	±1/4*	LSb	Low Range (VRR = 1)
		—	—	±1/2*	LSb	High Range (VRR = 0)
	Unit Resistor Value (R)	—	2K*	—	Ω	
	Settling Time ⁽¹⁾	—	—	10*	µs	

* These parameters are characterized but not tested.

Note 1: Settling time measured while VRR = 1 and VR<3:0> transitions from '0000' to '1111'.

PIC16F917/916/914/913

TABLE 19-11: PIC16F917/916/914/913 PLVD CHARACTERISTICS:

DC CHARACTERISTICS		Standard Operating Conditions (unless otherwise stated)					
		Operating Temperature		-40°C ≤ TA ≤ +125°C			
		Operating Voltage		VDD Range 2.0V-5.5V			
Sym.	Characteristic	Min	Typ†	Max	Units	Conditions	
VPLVD	PLVD Voltage	LVDL<2:0> = 000	TBD	1.9	TBD	V	
		TBD	TBD	2.0	TBD	V	
		TBD	TBD	2.1	TBD	V	
		TBD	TBD	2.2	TBD	V	
		TBD	TBD	2.3	TBD	V	
		TBD	TBD	4.0	TBD	V	
		TBD	TBD	4.2	TBD	V	
		TBD	TBD	4.5	TBD	V	

Legend: TBD = To Be Determined

† Data in 'Typ' column is at 5.0V, 25°C unless otherwise stated. These parameters are for design guidance only and are not tested.

ADVANCE INFORMATION

PIC16F917/916/914/913

FIGURE 19-11: SPI™ MASTER MODE TIMING (CKE = 0, SMP = 0)

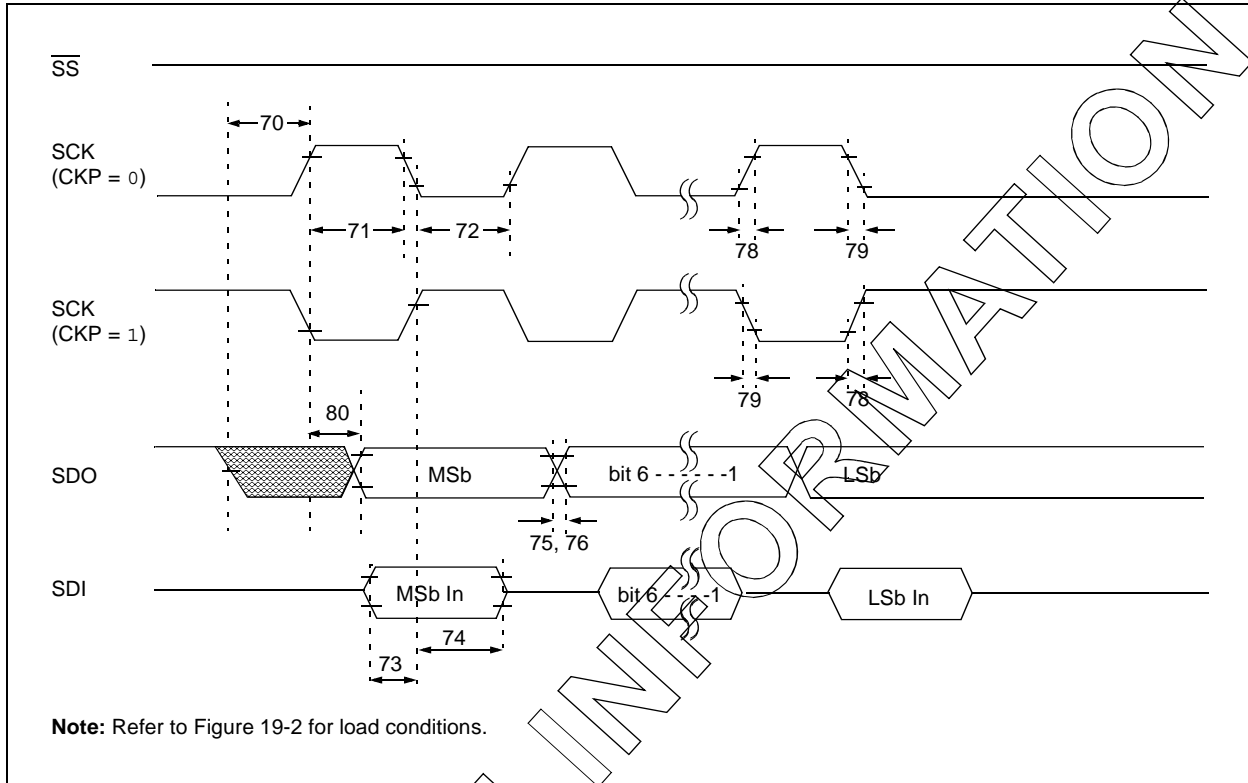

FIGURE 19-12: SPI™ MASTER MODE TIMING (CKE = 1, SMP = 1)

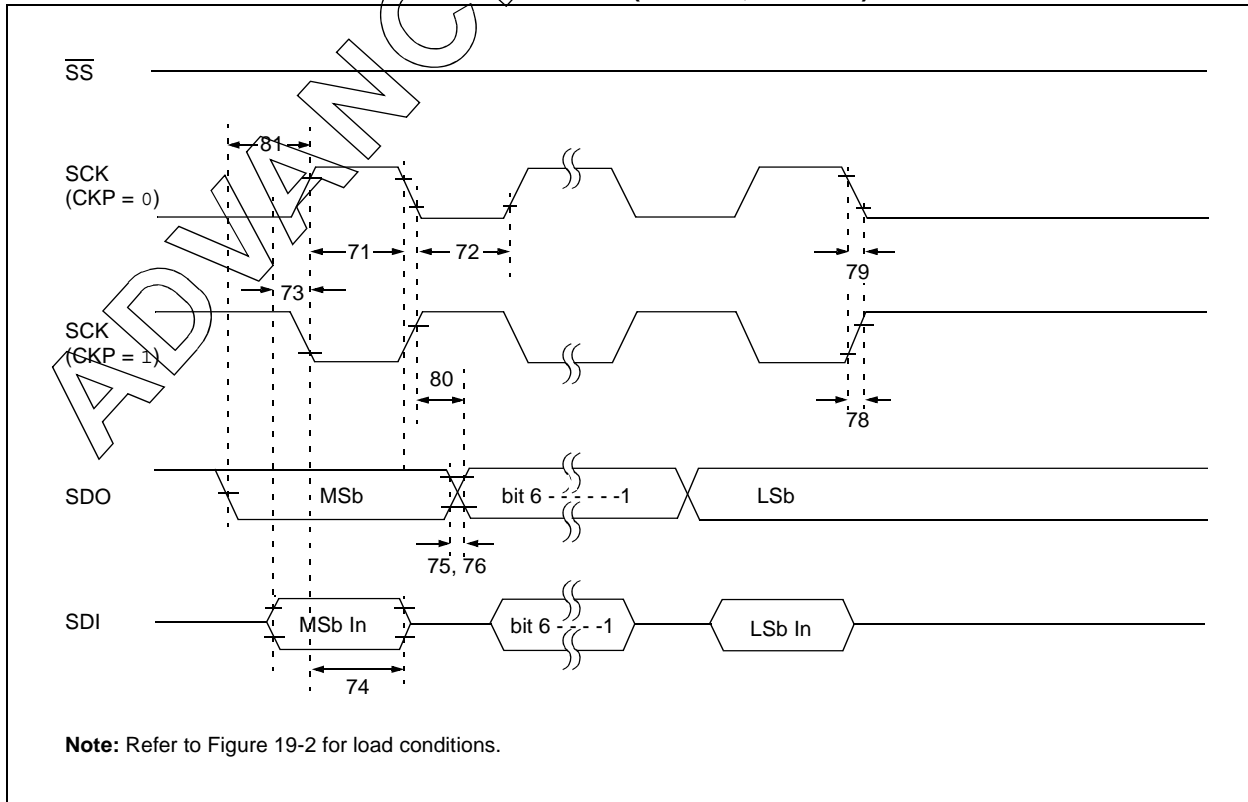

FIGURE 19-13: SPI™ SLAVE MODE TIMING (CKE = 0)

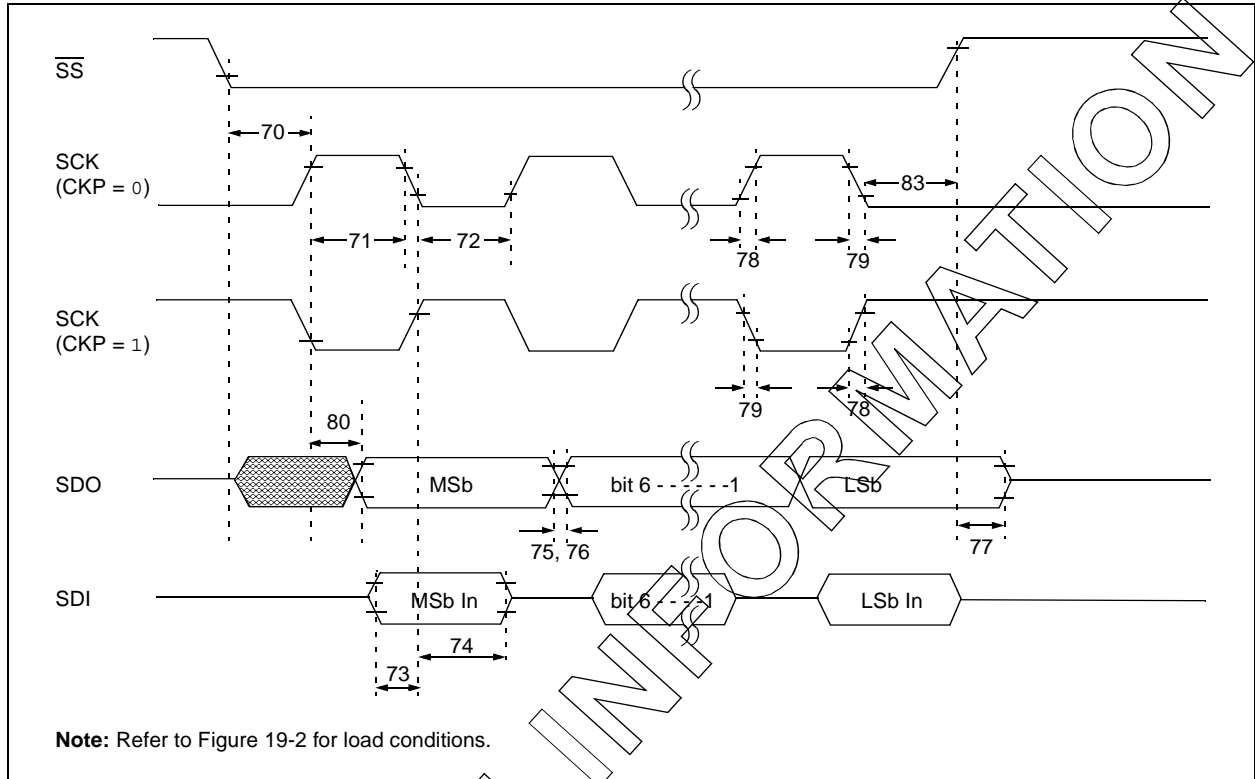
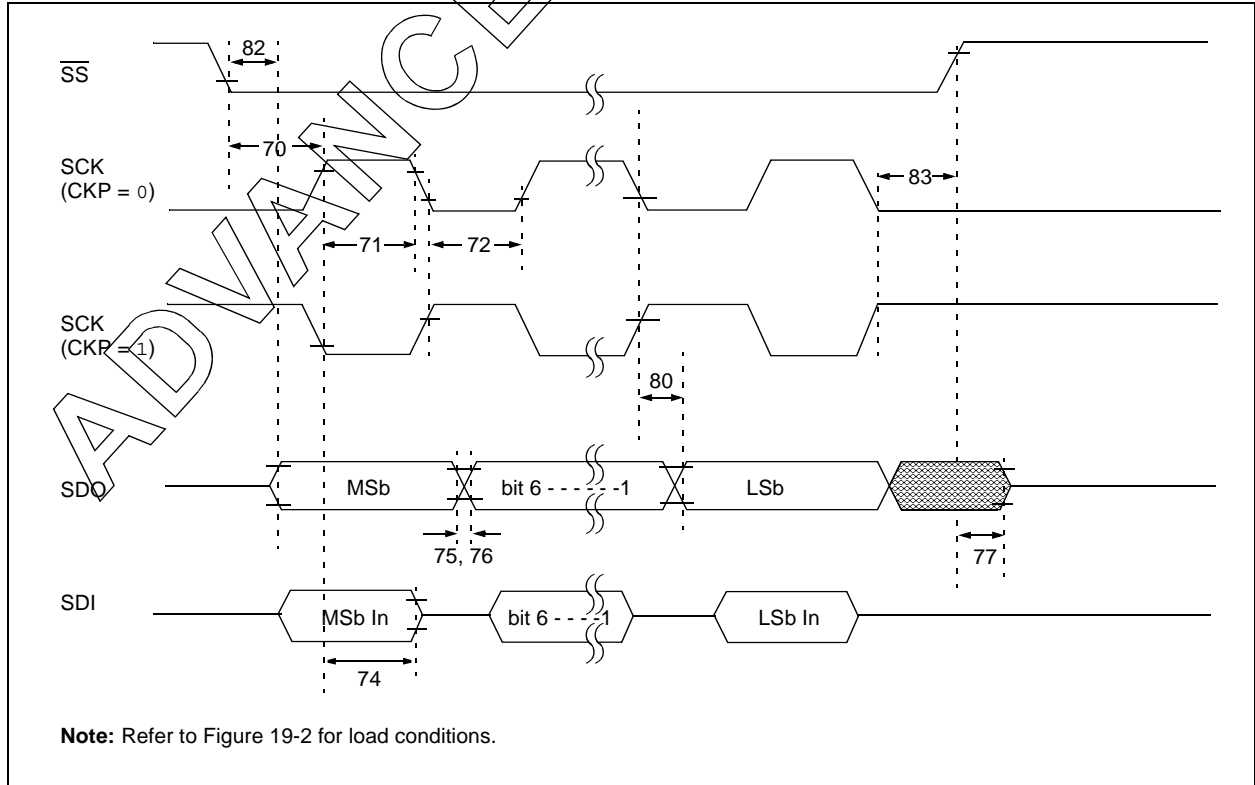

FIGURE 19-14: SPI™ SLAVE MODE TIMING (CKE = 1)



PIC16F917/916/914/913

TABLE 19-12: SPI™ MODE REQUIREMENTS

Param No.	Symbol	Characteristic		Min	Typ†	Max	Units	Conditions
70*	TssL2sch, TssL2scl	$\overline{SS}\downarrow$ to SCK \downarrow or SCK \uparrow input		Tcy	—	—	ns	
71*	Tsch	SCK input high time (Slave mode)		Tcy + 20	—	—	ns	
72*	Tscl	SCK input low time (Slave mode)		Tcy + 20	—	—	ns	
73*	TdIV2sch, TdIV2scl	Setup time of SDI data input to SCK edge		100	—	—	ns	
74*	Tsch2dIL, Tscl2dIL	Hold time of SDI data input to SCK edge		100	—	—	ns	
75*	TdoR	SDO data output rise time	3.0-5.5V	—	10	25	ns	
			2.0-5.5V	—	25	50	ns	
76*	TdoF	SDO data output fall time		—	10	25	ns	
77*	TssH2doZ	$\overline{SS}\uparrow$ to SDO output high-impedance		10	—	50	ns	
78*	Tscr	SCK output rise time (Master mode)	3.0-5.5V	—	10	25	ns	
			2.0-5.5V	—	25	50	ns	
79*	Tscf	SCK output fall time (Master mode)		—	10	25	ns	
80*	Tsch2doV, Tscl2doV	SDO data output valid after SCK edge	3.0-5.5V	—	—	50	ns	
			2.0-5.5V	—	—	145	ns	
81*	TdoV2sch, TdoV2scl	SDO data output setup to SCK edge		Tcy	—	—	ns	
82*	TssL2doV	SDO data output valid after $\overline{SS}\downarrow$ edge		—	—	50	ns	
83*	Tsch2ssh, Tscl2ssh	$\overline{SS}\uparrow$ after SCK edge		1.5Tcy + 40	—	—	ns	

* These parameters are characterized but not tested.

† Data in "Typ" column is at 5.0V, 25°C unless otherwise stated. These parameters are for design guidance only and are not tested.

FIGURE 19-15: I²C™ BUS START/STOP BITS TIMING

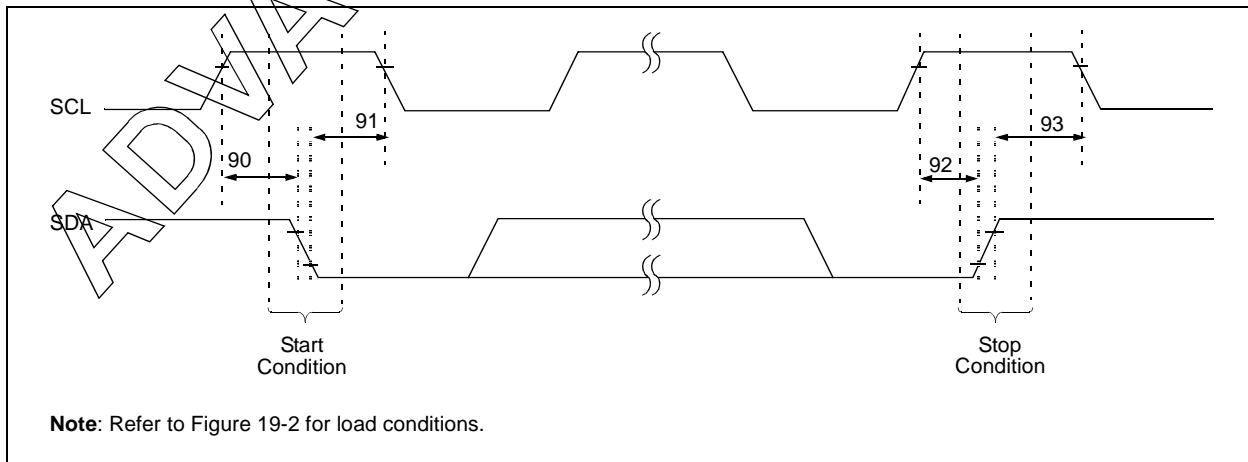
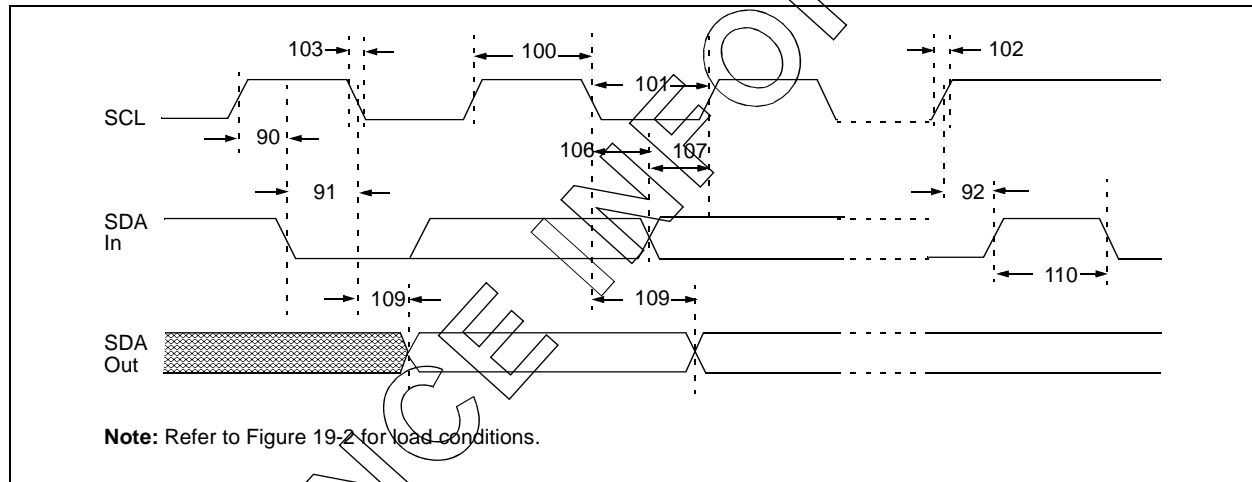

TABLE 19-13: I²C™ BUS START/STOP BITS REQUIREMENTS

Param No.	Symbol	Characteristic	Min	Typ	Max	Units	Conditions	
90*	TSU:STA	Start condition	100 kHz mode	4700	—	—	ns	Only relevant for Repeated Start condition
		Setup time	400 kHz mode	600	—	—		
91*	THD:STA	Start condition	100 kHz mode	4000	—	—	ns	After this period, the first clock pulse is generated
		Hold time	400 kHz mode	600	—	—		
92*	TSU:STO	Stop condition	100 kHz mode	4700	—	—	ns	
		Setup time	400 kHz mode	600	—	—		
93	THD:STO	Stop condition	100 kHz mode	4000	—	—	ns	
		Hold time	400 kHz mode	600	—	—		

* These parameters are characterized but not tested.

FIGURE 19-16: I²C™ BUS DATA TIMING



PIC16F917/916/914/913

TABLE 19-14: I²C™ BUS DATA REQUIREMENTS

Param. No.	Symbol	Characteristic	Min	Max	Units	Conditions	
100*	THIGH	Clock high time	100 kHz mode	4.0	—	μs	Device must operate at a minimum of 1.5 MHz
			400 kHz mode	0.6	—	μs	Device must operate at a minimum of 10 MHz
		SSP Module	1.5T _{cy}	—			
101*	TLOW						

TABLE 19-15: PIC16F917/916/914/913 A/D CONVERTER CHARACTERISTICS:

Standard Operating Conditions (unless otherwise stated) Operating Temperature $-40^{\circ}\text{C} \leq T_A \leq +125^{\circ}\text{C}$							
Param No.	Sym	Characteristic	Min	Typ†	Max	Units	Conditions
A01	NR	Resolution	—	—	10 bits	bits	
A03	EIL	Integral Error	—	—	$<\pm 1$	LSb	$V_{\text{REF}} = 5.0\text{V}$
A04	EDL	Differential Error	—	—	$<\pm 1$	LSb	No missing codes to 10 bits $V_{\text{REF}} = 5.0\text{V}$
A06	EOFF	Offset Error	—	—	$<\pm 1$	LSb	$V_{\text{REF}} = 5.0\text{V}$
A07	EGN	Gain Error	—	—	$<\pm 1$	LSb	$V_{\text{REF}} = 5.0\text{V}$
A10	—	Monotonicity	—	assured ⁽¹⁾	—	—	$V_{\text{SS}} \leq V_{\text{AIN}} \leq V_{\text{REF}+}$
A20	VREF	Reference Voltage ($V_{\text{REF}+} - V_{\text{REF}-}$)	2.5	—	V_{DD}	V	Full 10-bit accuracy
A21	VREF+	Reference Voltage High	$V_{\text{DD}} - 2.5\text{V}$	—	$V_{\text{DD}} + 0.3\text{V}$	V	
A22	VREF-	Reference Voltage Low	$V_{\text{SS}} - 0.3\text{V}$	—	$V_{\text{REF}+} - 2\text{V}$	V	
A25	VAIN	Analog Input Voltage	$V_{\text{SS}} - 0.3\text{V}$	—	$V_{\text{REF}+} + 0.3\text{V}$	V	
A30	ZAIN	Recommended Impedance of Analog Voltage Source	—	—	10	k Ω	
A50	IREF	VREF Input Current (2)	—	—	± 5 ± 150	μA μA	During VAIN acquisition. During A/D conversion cycle.

* These parameters are characterized but not tested.

† Data in 'Typ' column is at 5.0V, 25°C unless otherwise stated. These parameters are for design guidance only and are not tested.

Note 1: The A/D conversion result never decreases with an increase in the input voltage and has no missing codes.

Note 2: VREF+ current is from RA3/AN3/C1+/VREF+/SEG15 pin or VDD, whichever is selected as the VREF+ source. VREF- current is from RA2/AN2/C2+/VREF-/COM2 pin or VSS, whichever is selected as the VREF- source.

FIGURE 19-17: PIC16F917/916/914/913 A/D CONVERSION TIMING (NORMAL MODE)

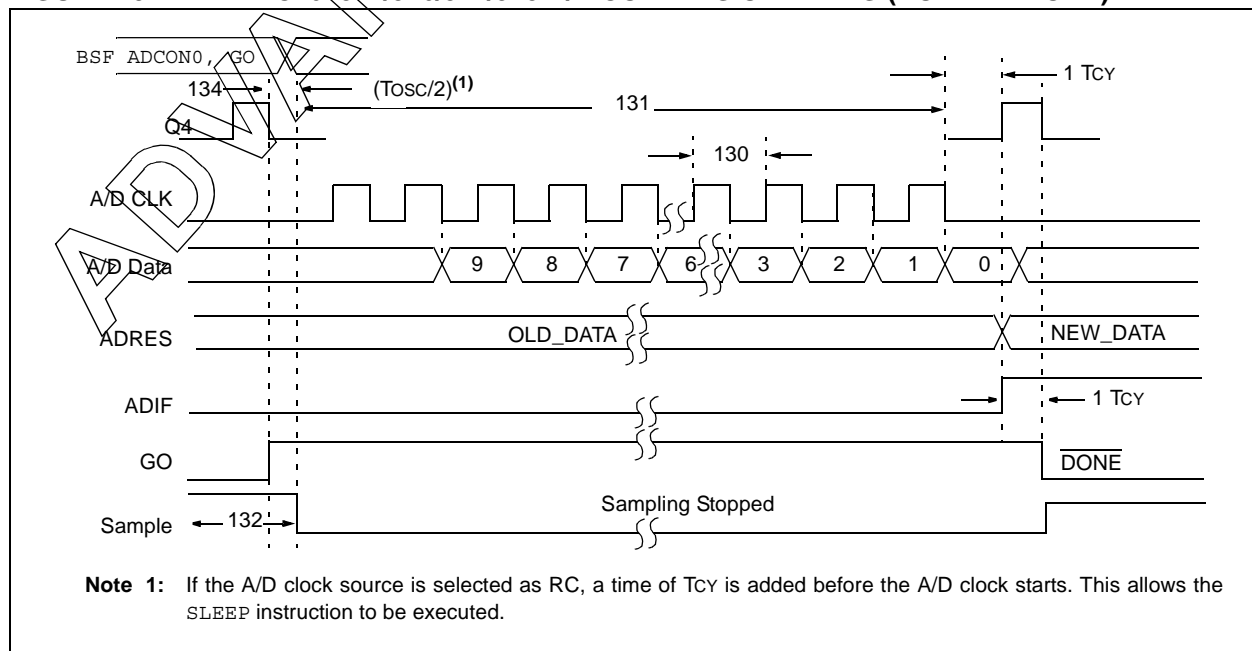

PIC16F917/916/914/913

TABLE 19-16: PIC16F917/916/914/913 A/D CONVERSION REQUIREMENTS

Standard Operating Conditions (unless otherwise stated)							
Operating Temperature $-40^{\circ}\text{C} \leq T_A \leq +125^{\circ}\text{C}$							
Param No.	Sym	Characteristic	Min	Typ†	Max	Units	Conditions
130	TAD	A/D Clock Period ⁽²⁾	1.6	—	—	μs	TOSC-based, $V_{\text{REF}} \geq 3.0\text{V}$
			3.0*	—	—	μs	TOSC-based, V_{REF} full range
130	TAD	A/D Internal RC Oscillator Period	3.0*	6.0	9.0*	μs	ADCS<1:0> = 11 (RC mode) At $V_{\text{DD}} = 2.5\text{V}$
			2.0*	4.0	6.0*	μs	At $V_{\text{DD}} = 5.0\text{V}$
131	TCNV	Conversion Time (not including Acquisition Time) ⁽¹⁾	—	11	—	TAD	Set GO/DONE bit to new data in A/D Result register
132	TACQ	Acquisition Time	5*	11.5	—	μs	The minimum time is the amplifier settling time. This may be used if the "new" input voltage has not changed by more than 1 LSB (i.e., 4.1 mV @ 4.096V) from the last sampled voltage (as stored on CHOLD).
						μs	
134	TGO	Q4 to A/D Clock Start	—	$T_{\text{OSC}}/2$	—	—	If the A/D clock source is selected as RC, a time of T_{CY} is added before the A/D clock starts. This allows the SLEEP instruction to be executed.

* These parameters are characterized but not tested.

† Data in 'Typ' column is at 5.0V, 25°C unless otherwise stated. These parameters are for design guidance only and are not tested.

Note 1: ADRESH and ADRESL registers may be read on the following T_{CY} cycle.

2: See Table 12-1 for minimum conditions.

ADVANCED INFORMATION

20.0 DC AND AC CHARACTERISTICS GRAPHS AND TABLES

Graphs are not available at this time.

PIC16F917/916/914/913

NOTES:

21.0 PACKAGING INFORMATION

21.1 Package Marking Information

28-Lead SPDIP

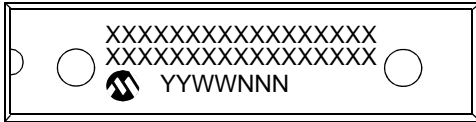

Example

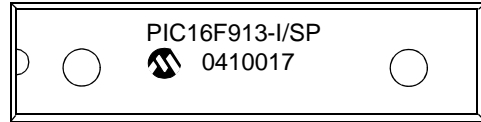

40-Lead PDIP

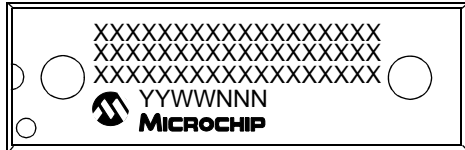

Example

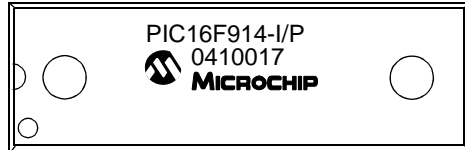

28-Lead QFN



Example

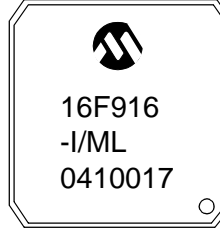

Legend:	XX...X	Customer-specific information
	Y	Year code (last digit of calendar year)
	YY	Year code (last 2 digits of calendar year)
	WW	Week code (week of January 1 is week '01')
	NNN	Alphanumeric traceability code
	(e3)	Pb-free JEDEC designator for Matte Tin (Sn)
	*	This package is Pb-free. The Pb-free JEDEC designator (e3) can be found on the outer packaging for this package.

Note: In the event the full Microchip part number cannot be marked on one line, it will be carried over to the next line, thus limiting the number of available characters for customer-specific information.

- * Standard PICmicro[®] device marking consists of Microchip part number, year code, week code and traceability code. For PICmicro device marking beyond this, certain price adders apply. Please check with your Microchip Sales Office. For QTP devices, any special marking adders are included in QTP price.

PIC16F917/916/914/913

Package Marking Information (Continued)

44-Lead QFN

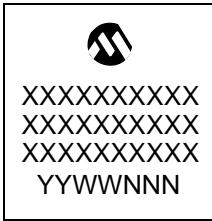

Example

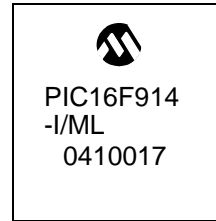

28-Lead SOIC



Example

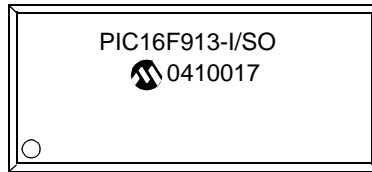

28-Lead SSOP

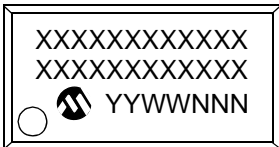

Example



44-Lead TQFP

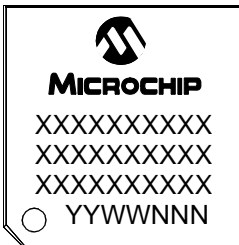

Example

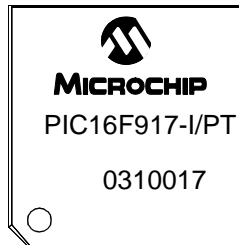

PIC16F917/916/914/913

40-Lead Plastic Dual In-line (P) – 600 mil Body (PDIP)

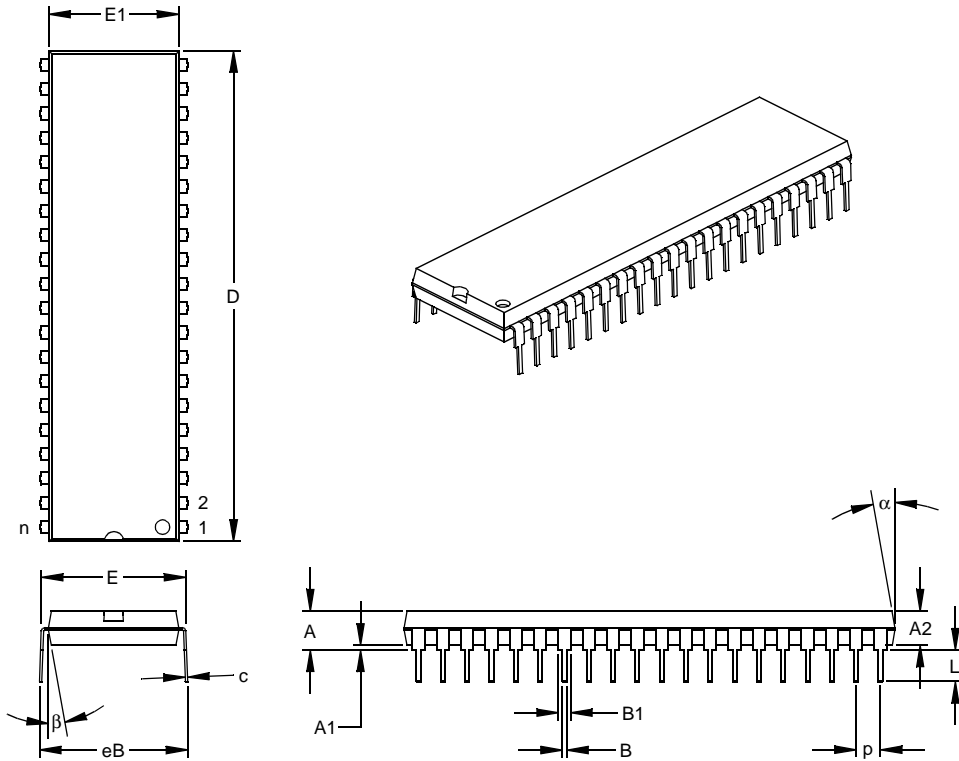

Dimension Limits	Units	INCHES*			MILLIMETERS		
		MIN	NOM	MAX	MIN	NOM	MAX
Number of Pins	n	40			40		
Pitch	p		.100			2.54	
Top to Seating Plane	A	.160	.175	.190	4.06	4.45	4.83
Molded Package Thickness	A2	.140	.150	.160	3.56	3.81	4.06
Base to Seating Plane	A1	.015			0.38		
Shoulder to Shoulder Width	E	.595	.600	.625	15.11	15.24	15.88
Molded Package Width	E1	.530	.545	.560	13.46	13.84	14.22
Overall Length	D	2.045	2.058	2.065	51.94	52.26	52.45
Tip to Seating Plane	L	.120	.130	.135	3.05	3.30	3.43
Lead Thickness	c	.008	.012	.015	0.20	0.29	0.38
Upper Lead Width	B1	.030	.050	.070	0.76	1.27	1.78
Lower Lead Width	B	.014	.018	.022	0.36	0.46	0.56
Overall Row Spacing	§ eB	.620	.650	.680	15.75	16.51	17.27
Mold Draft Angle Top	α	5	10	15	5	10	15
Mold Draft Angle Bottom	β	5	10	15	5	10	15

* Controlling Parameter

§ Significant Characteristic

Notes:

Dimensions D and E1 do not include mold flash or protrusions. Mold flash or protrusions shall not exceed .010" (0.254mm) per side.

JEDEC Equivalent: MO-011

Drawing No. C04-016

PIC16F917/916/914/913

28-Lead Plastic Quad Flat No Lead Package (ML) 6x6 mm Body (QFN) – With 0.55 mm Contact Length (Saw Singulated)

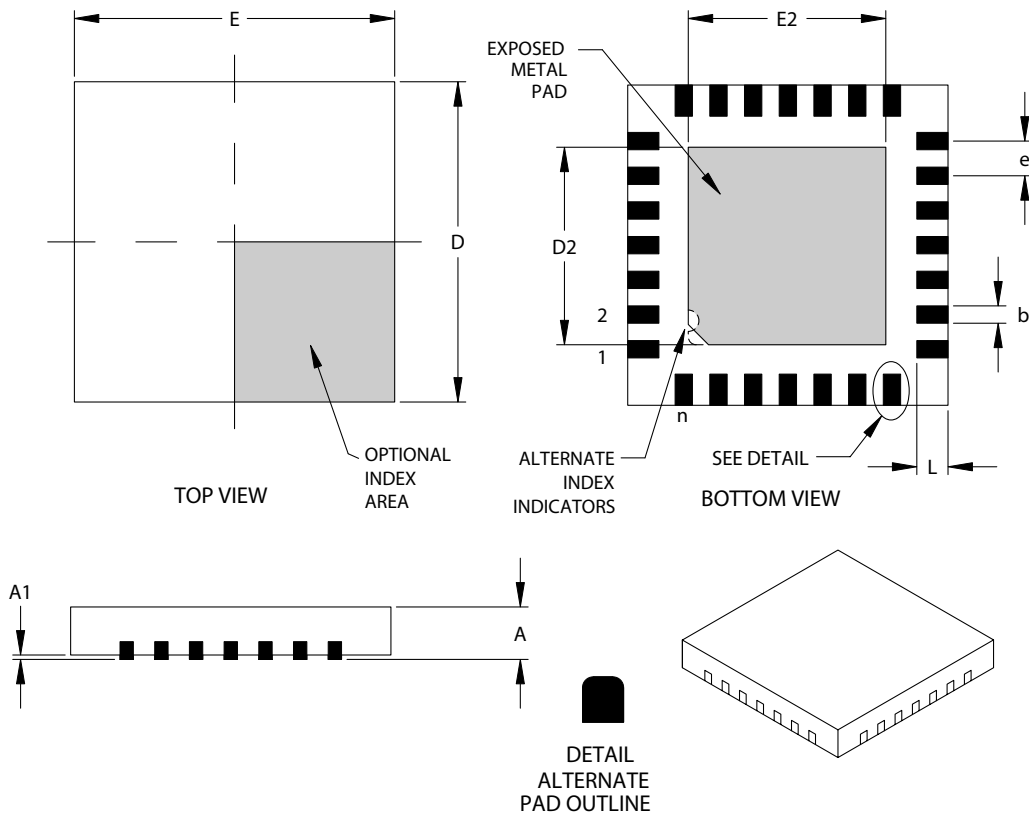

Dimension Limits	Units	INCHES			MILLIMETERS*		
		MIN	NOM	MAX	MIN	NOM	MAX
Number of Pins	n	28			28		
Pitch	e	.026 BSC			0.65 BSC		
Overall Height	A	.031	.035	.039	0.80	0.90	1.00
Standoff	A1	.000	.001	.002	0.00	0.02	0.05
Contact Thickness	A3	.008 REF			0.20 REF		
Overall Width	E	.232	.236	.240	5.90	6.00	6.10
Exposed Pad Width	E2	.140	.146	.152	3.55	3.70	3.85
Overall Length	D	.232	.236	.240	5.90	6.00	6.10
Exposed Pad Length	D2	.140	.146	.152	3.55	3.70	3.85
Contact Width	b	.009	.011	.013	0.23	0.28	0.33
Contact Length	L	.020	.024	.028	0.50	0.60	0.70

*Controlling Parameter

Notes:

JEDEC equivalent: MO-220

Drawing No. C04-105

Revised 05-24-04

PIC16F917/916/914/913

44-Lead Plastic Quad Flat No Lead Package (ML) 8x8 mm Body (QFN)

Dimension Limits	Units	INCHES			MILLIMETERS*		
		MIN	NOM	MAX	MIN	NOM	MAX
Number of Contacts	n	44			44		
Pitch	P	.026 BSC			0.65 BSC		
Overall Height	A		.035	.039		0.90	1.00
Standoff	A1	.000	.001	.002	0	0.02	0.05
Base Thickness	(A3)	.010 REF			0.25 REF		
Overall Width	E						
Exposed Pad Width	E2						
Overall Length	D		.315			8.00	
Exposed Pad Length	D2	.246					
Contact Width	B	.008	.013	.013	0.20	0.33	0.35
Contact Length	L	.014	.016	.019	0.35	0.40	0.48

*Controlling Parameter

Notes:

- 1.
- 2.

Drawing No. C04-103

PIC16F917/916/914/913

28-Lead Plastic Small Outline (SO) – Wide, 300 mil Body (SOIC)

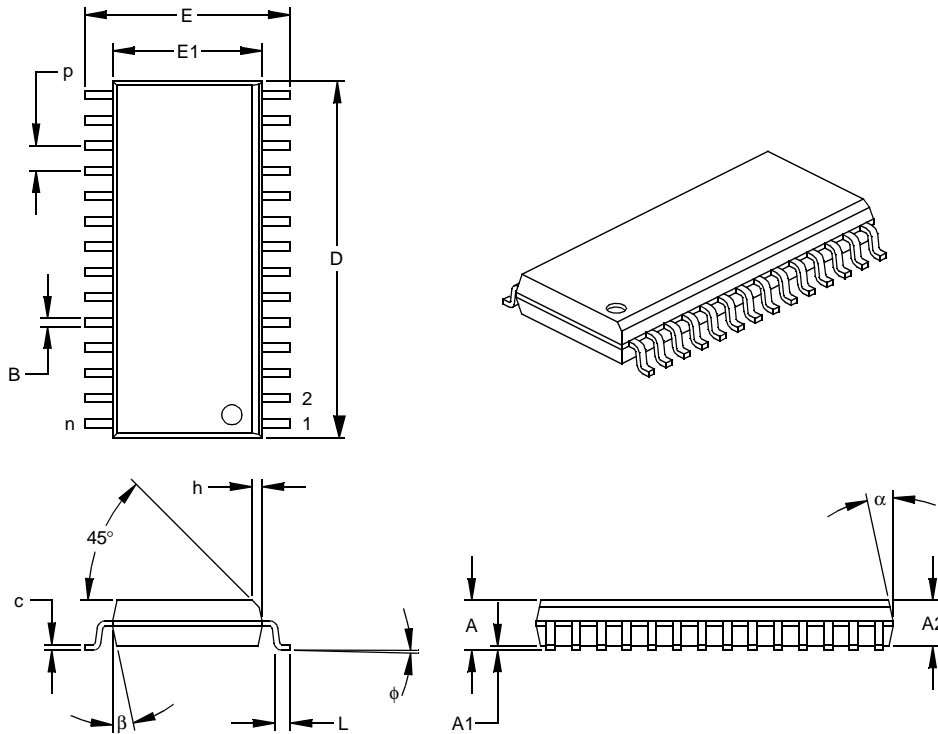

Dimension Limits	Units	INCHES*			MILLIMETERS		
		MIN	NOM	MAX	MIN	NOM	MAX
Number of Pins	n	28			28		
Pitch	p		.050			1.27	
Overall Height	A	.093	.099	.104	2.36	2.50	2.64
Molded Package Thickness	A2	.088	.091	.094	2.24	2.31	2.39
Standoff §	A1	.004	.008	.012	0.10	0.20	0.30
Overall Width	E	.394	.407	.420	10.01	10.34	10.67
Molded Package Width	E1	.288	.295	.299	7.32	7.49	7.59
Overall Length	D	.695	.704	.712	17.65	17.87	18.08
Chamfer Distance	h	.010	.020	.029	0.25	0.50	0.74
Foot Length	L	.016	.033	.050	0.41	0.84	1.27
Foot Angle Top	φ	0	4	8	0	4	8
Lead Thickness	c	.009	.011	.013	0.23	0.28	0.33
Lead Width	B	.014	.017	.020	0.36	0.42	0.51
Mold Draft Angle Top	α	0	12	15	0	12	15
Mold Draft Angle Bottom	β	0	12	15	0	12	15

* Controlling Parameter
 § Significant Characteristic

Notes:

Dimensions D and E1 do not include mold flash or protrusions. Mold flash or protrusions shall not exceed .010" (0.254mm) per side.

JEDEC Equivalent: MS-013

Drawing No. C04-052

PIC16F917/916/914/913

28-Lead Plastic Shrink Small Outline (SS) – 209 mil Body, 5.30 mm (SSOP)

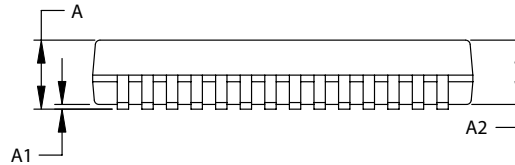
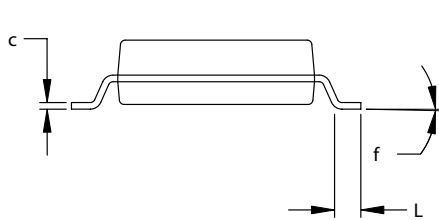
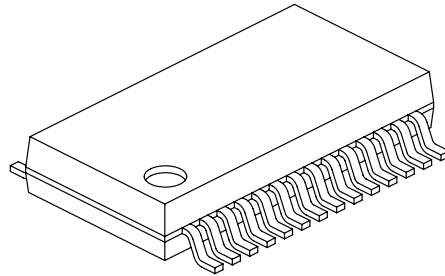
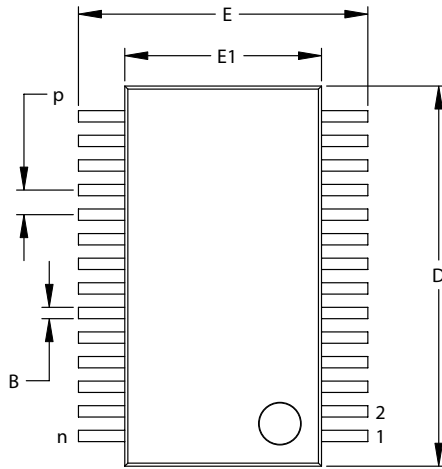

Dimension Limits	Units	INCHES			MILLIMETERS*		
		MIN	NOM	MAX	MIN	NOM	MAX
Number of Pins	n	28			28		
Pitch	P		.026			0.65	
Overall Height	A	-	-	.079	-	-	2.0
Molded Package Thickness	A2	.065	.069	.073	1.65	1.75	1.85
Standoff	A1	.002	-	-	0.05	-	-
Overall Width	E	.295	.307	.323	7.49	7.80	8.20
Molded Package Width	E1	.009	.209	.220	5.00	5.30	5.60
Overall Length	D	.390	.402	.413	9.90	10.20	10.50
Foot Length	L	.022	.030	.037	0.55	0.75	0.95
Lead Thickness	c	.004	-	.010	0.09	-	0.25
Foot Angle	f	0°	4°	8°	0°	4°	8°
Lead Width	B	.009	-	.015	0.22	-	0.38

*Controlling Parameter

Notes:

Dimensions D and E1 do not include mold flash or protrusions. Mold flash or protrusions shall not exceed .010" (0.254mm) per side.

JEDEC Equivalent: MO-150

Drawing No. C04-073

PIC16F917/916/914/913

44-Lead Plastic Thin Quad Flatpack (PT) 10x10x1 mm Body, 1.0/0.10 mm Lead Form (TQFP)

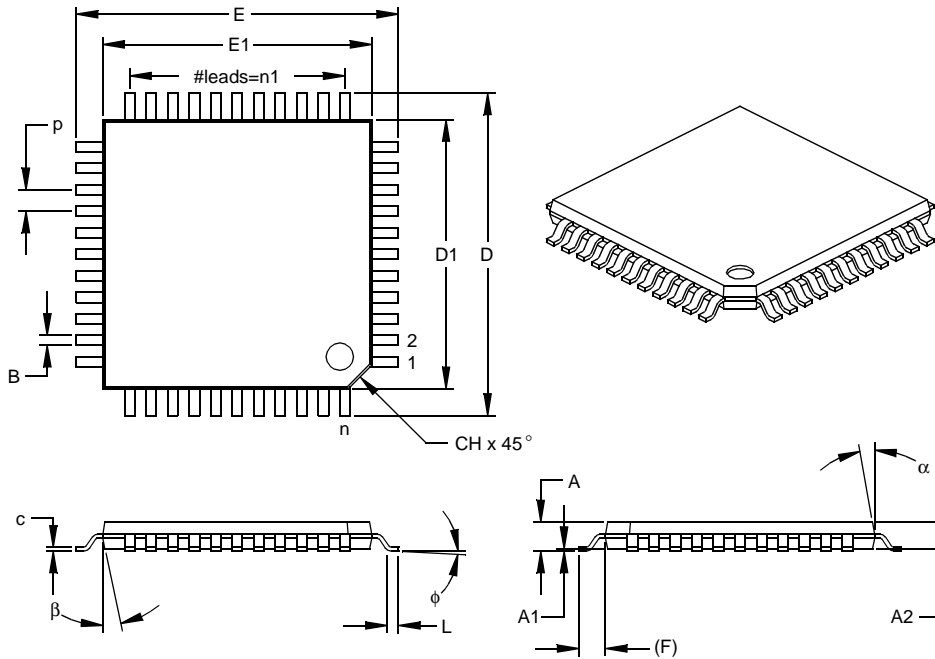

Dimension Limits	Units	INCHES			MILLIMETERS*		
		MIN	NOM	MAX	MIN	NOM	MAX
Number of Pins	n	44			44		
Pitch	p		.031			0.80	
Pins per Side	n1		11			11	
Overall Height	A	.039	.043	.047	1.00	1.10	1.20
Molded Package Thickness	A2	.037	.039	.041	0.95	1.00	1.05
Standoff §	A1	.002	.004	.006	0.05	0.10	0.15
Foot Length	L	.018	.024	.030	0.45	0.60	0.75
Footprint (Reference)	(F)		.039		1.00		
Foot Angle	φ	0	3.5	7	0	3.5	7
Overall Width	E	.463	.472	.482	11.75	12.00	12.25
Overall Length	D	.463	.472	.482	11.75	12.00	12.25
Molded Package Width	E1	.390	.394	.398	9.90	10.00	10.10
Molded Package Length	D1	.390	.394	.398	9.90	10.00	10.10
Lead Thickness	c	.004	.006	.008	0.09	0.15	0.20
Lead Width	B	.012	.015	.017	0.30	0.38	0.44
Pin 1 Corner Chamfer	CH	.025	.035	.045	0.64	0.89	1.14
Mold Draft Angle Top	α	5	10	15	5	10	15
Mold Draft Angle Bottom	β	5	10	15	5	10	15

* Controlling Parameter

§ Significant Characteristic

Notes:

Dimensions D1 and E1 do not include mold flash or protrusions. Mold flash or protrusions shall not exceed

.010" (0.254mm) per side.

JEDEC Equivalent: MS-026

Drawing No. C04-076

PIC16F917/916/914/913

APPENDIX A: DATA SHEET REVISION HISTORY

Revision A

This is a new data sheet.

Revision B

Updated Peripheral Features.
Page 2, Table: Corrected I/O numbers.
Figure 8-3: Revised Comparator I/O operating modes.
Register 9-1, Table: Corrected max. number of pixels.

Revision C

Correction to Pin Description Table.
Correction to IPD base and T1OSC.

Revision D

Revised references 31.25 kHz to 31 kHz.
Revised Standby Current to 100 nA.
Revised 9.1: internal RC oscillator to internal LF oscillator.

APPENDIX B: MIGRATING FROM OTHER PICmicro® DEVICES

This discusses some of the issues in migrating from other PICmicro devices to the PIC16F917/916/914/913 family of devices.

B.1 PIC16F676 to PIC16F917/916/914/ 913

TABLE B-1: FEATURE COMPARISON

Feature	PIC16F676	PIC16F917/ 916/914/913
Max Operating Speed	20 MHz	20 MHz
Max Program Memory (Words)	1K	8K
Max SRAM (Bytes)	64	352
A/D Resolution	10-bit	10-bit
Data EEPROM (bytes)	128	256
Timers (8/16-bit)	1/1	2/1
Oscillator Modes	8	8
Brown-out Reset	Y	Y
Internal Pull-ups	RB0/1/2/4/5	RB<7:0>
Interrupt-on-change	RB0/1/2/3 /4/5	RB<7:4>
Comparator	1	2
USART	N	Y
Extended WDT	N	Y
Software Control Option of WDT/BOR	N	Y
INTOSC Frequencies	4 MHz	32 kHz - 8 MHz
Clock Switching	N	Y

PIC16F917/916/914/913

APPENDIX C: CONVERSION CONSIDERATIONS

Considerations for converting from previous versions of devices to the ones listed in this data sheet are listed in Table C-1.

TABLE C-1: CONVERSION CONSIDERATIONS

Characteristic	PIC16F917/916/914/913	PIC16F87X	PIC16F87XA
Pins	28/40	28/40	28/40
Timers	3	3	3
Interrupts	11 or 12	13 or 14	14 or 15
Communication	USART, SSP (SPI™, I ² C™ Slave)	PSP, USART, SSP (SPI, I ² C Master/Slave)	PSP, USART, SSP (SPI, I ² C Master/Slave)
Frequency	20 MHz	20 MHz	20 MHz
Voltage	2.0V-5.5V	2.2V-5.5V	2.0V-5.5V
A/D	10-bit, 7 conversion clock selects	10-bit, 4 conversion clock selects	10-bit, 7 conversion clock selects
CCP	2	2	2
Comparator	2	—	2
Comparator Voltage Reference	Yes	—	Yes
Program Memory	4K, 8K EPROM	4K, 8K Flash (Erase/Write on single-word)	4K, 8K Flash (Erase/Write on four-word blocks)
RAM	256, 352 bytes	192, 368 bytes	192, 368 bytes
EEPROM Data	256 bytes	128, 256 bytes	128, 256 bytes
Code Protection	On/Off	Segmented, starting at end of program memory	On/Off
Program Memory Write Protection	—	On/Off	Segmented, starting at beginning of program memory
LCD Module	16, 24 segment drivers, 4 commons	—	—
Other	In-Circuit Debugger, Low-Voltage Programming	In-Circuit Debugger, Low-Voltage Programming	In-Circuit Debugger, Low-Voltage Programming

INDEX

A

A/D

Acquisition Requirements	149
Analog Port Pins	144
Associated Registers	151
Block Diagram	143
Calculating Acquisition Time	149
Channel Selection	144
Configuration and Operation	144
Configuring	148
Configuring Interrupt	148
Conversion (TAD) Cycles	145
Conversion Clock	144
Effects of Reset	151
Internal Sampling Switch (RSS) Impedance	149
Operation During Sleep	150
Output Format	145
Reference Voltage (VREF)	144
Source Impedance	149
Specifications	246
Starting a Conversion	145
TAD vs. Operating Frequencies	144
Absolute Maximum Ratings	221
AC Characteristics	
Industrial and Extended	231
Load Conditions	230
ACK pulse	169
ADCON0 Register	146
ADCON1 Register	147
Addressable Universal Synchronous Asynchronous Receiver Transmitter. See USART	
Analog Input Connections	94
Analog-to-Digital Converter Module. See A/D	
ANSEL Register	146
Assembler	
MPASM Assembler	215
Asynchronous Reception	
Associated Registers	135, 137
Asynchronous Transmission	
Associated Registers	133

B

Baud Rate Generator	
Associated Registers	129
BF bit	160
Block Diagrams	
A/D	143
Analog Input Model	94, 150
Capture Mode	179
Comparator 1	96
Comparator 2	96
Comparator Modes	95
Comparator Voltage Reference (CVREF)	98
Compare Mode	180
Fail-Safe Clock Monitor (FSCM)	79
In-Circuit Serial Programming Connections	203
Interrupt Logic	196
LCD Clock Generation	108
LCD Driver Module	102
LCD Resistor Ladder Connection	106
MCLR Circuit	188
On-Chip Reset Circuit	187
PIC16F913/916	8
PIC16F914/917	9

PWM Mode	181
RA0 Pin	33
RA1 Pin	34
RA2 Pin	35
RA3 Pin	36
RA4 Pin	37
RA5 Pin	38
RA6 Pin	39
RA7 Pin	40
RB Pins	45
RB4 Pin	46
RB5 Pin	47
RB6 Pin	48
RB7 Pin	49
RC0 Pin	52
RC1 Pin	53
RC2 Pin	53
RC3 Pin	54
RC4 Pin	55
RC5 Pin	56
RC6 Pin	57
RC7 Pin	58
RD Pins	63
RD0 Pin	62
RD1 Pin	62
RD2 Pin	63
RE Pins	66
Resonator Operation	74
SSP (I ² C Mode)	169
SSP (SPI Mode)	162
System Clock	69
Timer1	85
Timer2	91
TMR0/WDT Prescaler	81
USART Receive	135, 136
USART Transmit	132
Watchdog Timer (WDT)	199
BRGH bit	129
Brown-out Reset (BOR)	189
Associated Registers	190
Calibration	189
Specifications	235
Timing and Characteristics	234

C

C Compilers	
MPLAB C17	216
MPLAB C18	216
MPLAB C30	216
Capture/Compare/PWM (CCP)	177
Associated Registers	
Capture, Compare and Timer1	182
PWM and Timer2	183
Capture Mode	179
Block Diagram	179
CCP1CON Register	178
CCP1IF	179
Prescaler	179
CCP Timer Resources	177
Compare	
Special Trigger Output of CCP1	180
Special Trigger Output of CCP2	180
Compare Mode	180
Block Diagram	180

PIC16F917/916/914/913

Software Interrupt Mode	180
Special Event Trigger.....	180
Interaction of Two CCP Modules (table)	177
PWM Mode	180
Block Diagram.....	181
Duty Cycle.....	181
Example Frequencies/Resolutions (table)	182
PWM Period.....	181
Special Event Trigger and A/D Conversions.....	180
CCP. See Capture/Compare/PWM	
CCP1CON Register	64, 178
CCPR1H Register	177
CCPR1L Register.....	177
CCPxM0 bit	178
CCPxM1 bit	178
CCPxM2 bit	178
CCPxM3 bit	178
CCPxX bit.....	178
CCPxY bit.....	178
CKE bit	160
CKP bit	161
CMCON0 Register	93
CMCON1 Register	97
Code Examples	
A/D Conversion	148
Assigning Prescaler to Timer0	83
Assigning Prescaler to WDT	83
Call of a Subroutine in Page 1 from Page 0.....	29
Indirect Addressing	30
Initializing PORTA	31
Initializing PORTB.....	41
Initializing PORTC.....	51
Initializing PORTD.....	60
Initializing PORTE.....	65
Loading the SSPBUF (SSPSR) Register	163
Saving Status and W Registers in RAM	198
Code Protection	203
Comparator Module	93
Comparator Voltage Reference (CVREF)	
Associated Registers	100
Effects of a Reset.....	99
Response Time	99
Comparator Voltage Reference (CVREF)	98
Accuracy/Error	98
Configuring.....	98
Specifications.....	238
Comparators	
Associated Registers	100
C2OUT as T1 Gate	86, 97
Configurations.....	95
Effects of a Reset.....	99
Interrupts.....	97
Operation	94
Operation During Sleep	99
Outputs	97
Response Time.....	99
Specifications.....	238
Synchronizing C2OUT w/ Timer1	97
CONFIG Register.....	186
Configuration Bits.....	186
Conversion Considerations	260
CPU Features	185
Customer Change Notification Service	269
Customer Notification Service.....	269
Customer Support.....	269
D	
D/Ā bit.....	160
Data EEPROM Memory.....	153
Associated Registers.....	158
Reading	156
Writing	156
Data Memory	14
Data/Address bit (D/Ā).....	160
DC Characteristics	
Extended and Industrial.....	228
Industrial and Extended.....	223
Demonstration Boards	
PICDEM 1.....	218
PICDEM 17.....	219
PICDEM 18R.....	219
PICDEM 2 Plus.....	218
PICDEM 3.....	218
PICDEM 4.....	218
PICDEM LIN	219
PICDEM USB	219
PICDEM.net Internet/Ethernet.....	218
Development Support.....	215
Device Overview.....	7
E	
EEADRH Registers.....	153, 154
EEADRL Registers	153, 154
EECON1 Register.....	153, 155
EECON2 Register.....	153
EEDATH Register.....	154
EEDATL Register	154
Electrical Specifications	221
Enhanced Capture/Compare/PWM (ECCP)	
Enhanced PWM Mode	
TMR2 to PR2 Match	90
Errata	5
Evaluation and Programming Tools.....	219
F	
Fail-Safe Clock Monitor	79
Fail-Safe Condition Clearing.....	80
Reset and Wake-up from Sleep.....	80
Firmware Instructions	205
Flash Program Memory	153
Fuses. See Configuration Bits	
G	
General Purpose Register File	14
I	
I/O Ports.....	31
I ² C Mode	
Addressing.....	170
Associated Registers.....	176
Master Mode.....	175
Mode Selection	169
Multi-Master Mode.....	175
Operation	169
Reception	171
Slave Mode	
SCL and SDA pins.....	169
Transmission	173
ID Locations.....	203
In-Circuit Debugger.....	204
In-Circuit Serial Programming (ICSP).....	203

Indirect Addressing, INDF and FSR Registers	30
Instruction Format	206
Instruction Set	205
ADDLW	208
ADDWF	208
ANDLW	208
ANDWF	208
BCF	208
BSF	208
BTFSC	209
BTFSS	208
CALL	209
CLRF	209
CLRWF	209
CLRWDT	209
COMF	209
DECF	209
DECFSZ	210
GOTO	210
INCF	210
INCFSZ	210
IORLW	210
IORWF	210
MOVF	211
MOVLW	211
MOVWF	211
NOP	211
RETFIE	212
RETLW	212
RETURN	212
RLF	213
RRF	213
SLEEP	213
SUBLW	213
SUBWF	213
SWAPF	214
XORLW	214
XORWF	214
Summary Table	207
INTCON Register	23
Inter-Integrated Circuit (I ² C). See I ² C Mode	
Internal Oscillator Block	
INTOSC	
Specifications	232
Internal Sampling Switch (Rss) Impedance	149
Internet Address	269
Interrupt Sources	
USART Receive/Transmit Complete	127
Interrupts	195
A/D	148
Associated Registers	197
Comparators	97
Context Saving	198
Interrupt-on-change	41
PORTB Interrupt-on-Change	196
RB0/INT/SEG0	196
TMR0	196
TMR1	86
TMR2 to PR2 Match	91
TMR2 to PR2 Match (PWM)	90
INTOSC Specifications	232
IOCB Register	42

L

LCD

Associated Registers	124
Bias Types	106
Clock Source Selection	106
Configuring the Module	124
Frame Frequency	107
Interrupts	121
LCDCON Register	101
LCDDATA Register	101
LCDPS Register	101
LCDSE Register	101
Multiplex Types	107
Operation During Sleep	122
Pixel Control	107
Prescaler	106
Segment Enables	107
Waveform Generation	110
LCDCON Register	101
LCDDATA Register	101
LCDPS Register	101
LP Bits	106
LCDSE Register	101
Liquid Crystal Display (LCD) Driver	101
Load Conditions	230

M

MCLR	188
Internal	188
Memory Organization	13
Data	14
Program	13
Microchip Internet Web Site	269
Migrating from other PICmicro Devices	259
MPLAB ASM30 Assembler, Linker, Librarian	216
MPLAB ICD 2 In-Circuit Debugger	217
MPLAB ICE 2000 High-Performance Universal	
In-Circuit Emulator	217
MPLAB ICE 4000 High-Performance Universal	
In-Circuit Emulator	217
MPLAB Integrated Development Environment Software ..	215
MPLAB PM3 Device Programmer	217
MPLINK Object Linker/MPLIB Object Librarian	216

O

OPCODE Field Descriptions	205
OPTION_REG Register	22, 82
OSCCON Register	70
Oscillator	
Associated Registers	80
Oscillator Configurations	69
Oscillator Delay Examples	72
Special Cases	71
Oscillator Specifications	231
Oscillator Start-up Timer (OST)	
Specifications	235
Oscillator Switching	
Fail-Safe Clock Monitor	79
Two-Speed Clock Start-up	78
OSCTUNE Register	76

PIC16F917/916/914/913

P	
P (Stop) bit	160
Packaging	249
Marking	249, 250
PDIP Details	251
SOIC Details	256
TSSOP Details	256
Paging, Program Memory	29
PCL and PCLATH	29
Computed GOTO	29
Stack	29
PCON Register	190
PICkit 1 Flash Starter Kit	219
PICSTART Plus Development Programmer	218
PIE1 Register	24
PIE2 Register	25
Pin Diagram	
PIC16F913/916, 28-pin	3
PIC16F914/917, 40-pin	2
PIC16F914/917, 44-pin	4
Pinout Description	10
PIR1 Register	26
PIR2 Register	27
PORTA	
Associated Registers	40
Pin Descriptions and Diagrams	33
RA0	33
RA1	34
RA2	35
RA3	36
RA4	37
RA5	38
RA6	39
RA7	40
Registers	31
Specifications	233
PORTA Register	32
PORTB	
Additional Pin Functions	41
Weak Pull-up	41
Associated Registers	50
Interrupt-on-change	41
Pin Descriptions and Diagrams	44
RB0	44
RB1	44
RB2	44
RB3	44
RB4	46
RB5	47
RB6	48
RB7	49
Registers	41
PORTB Register	42
PORTC	
Associated Registers	59
Pin Descriptions and Diagrams	52
RC0	52
RC1	52
RC2	52
RC3	54
RC4	55
RC5	56
RC6	57
RC6/TX/CK/SCK/SCL/SEG9 Pin	128
RC7	58
RC7/RX/DT Pin	129
RC7/RX/DT/SDI/SDA/SEG8 Pin	128
Registers	51
Specifications	233
TRISC Register	127
PORTC Register	51
PORTD	
Associated Registers	64
Pin Descriptions and Diagrams	61
RD0	61
RD1	61
RD2	61
RD3	61
RD4	61
RD5	61
RD6	61
RD7	61
Registers	60
PORTD Register	60
PORTE	
Associated Registers	67
Pin Descriptions and Diagrams	66
RE0	66
RE1	66
RE2	66
RE3	66
Registers	65
PORTE Register	65
Power-Down Mode (Sleep)	201
Power-on Reset	188
Power-up Timer (PWRT)	188
Specifications	235
Precision Internal Oscillator Parameters	232
Prescaler	
Shared WDT/Timer0	83
Switching Prescaler Assignment	83
PRO MATE II Universal Device Programmer	217
Product Identification System	271
Program Memory	13
Map and Stack (PIC16F913/914)	13
Map and Stack (PIC16F916/917)	13
Paging	29
Programmable Low-Voltage Detect (PLVD) Module	125
Programming, Device Instructions	205
Pulse Width Modulation. See Capture/Compare/PWM, PWM Mode.	
R	
$\overline{R/W}$ bit	160
RCSTA Register	
ADDEN Bit	128
CREN Bit	128
FERR Bit	128
OERR Bit	128
RX9 Bit	128
RX9D Bit	128
SPEN Bit	127, 128
SREN Bit	128
Reader Response	270
Read-Modify-Write Operations	205
Receive Overflow Indicator bit (SSPOV)	161
Registers	
ADCON0 (A/D Control 0)	146
ADCON1 (A/D Control 1)	147
ANSEL (Analog Select)	146
CCP1CON (CCP Control 2)	178

CCP2CON (CCP Control 1).....	178
CMCON0 (Comparator Control 0)	93
CMCON1 (Comparator Control 1)	97
CONFIG (Configuration Word).....	186
EEADRH (EEPROM Address).....	154
EEADRL (EEPROM Address)	154
EEDATL (EEPROM Data).....	154
EEDATH (EEPROM Data).....	154
ECON1 (EEPROM Control 1).....	155
INTCON (Interrupt Control).....	23
IOCB (PORTB Interrupt-on-change).....	42
LCDCON (LCD Control).....	103
LCDDATAx (LCD Datax)	105
LCDPS (LCD Prescaler Select)	104
LCDSEn (LCD Segment)	105
LVDCON (Low-Voltage Detect Control).....	125
OPTION_REG	22, 82
OSCCON (Oscillator Control)	70
OSCTUNE	76
PCON (Power Control)	190
PIE1 (Peripheral Interrupt Enable 1).....	24
PIE2 (Peripheral Interrupt Enable 2).....	25

PIC16F917/916/914/913

Selecting Source.....	86, 97	Type-B in 1/3 Mux, 1/2 Bias Drive	116
Synchronizing C2OUT w/ Timer1	97	Type-B in 1/3 Mux, 1/3 Bias Drive	118
TMR1H Register	85	Type-B in 1/4 Mux, 1/3 Bias Drive	120
TMR1L Register	85	USART Synchronous Receive (Master/Slave)	237
Timer1 Module with Gate Control	85	USART Synchronous Transmission (Master/Slave)	236
Timer2	90	Wake-up from Interrupt.....	202
Associated registers.....	91	Timing Parameter Symbology	230
Operation	90	Timing Requirements	
Postscaler	90	I ² C Bus Data.....	244
PR2 Register.....	90	I2C Bus Start/Stop Bits	243
Prescaler	90	SPI Mode	242
TMR2 Output	91	TMR1H Register.....	85
TMR2 Register.....	90	TMR1L Register.....	85
TMR2 to PR2 Match Interrupt	90, 91	TRISA	
Timing Diagrams		Registers	31
A/D Conversion.....	245		
Asynchronous Master Transmission	132		
Asynchronous Master Transmission (Back-to-Back)	132		
Asynchronous Reception	135		
Asynchronous Reception with Address Byte First	137		
Asynchronous Reception with Address Detect	137		
Brown-out Reset (BOR)	234		
Brown-out Reset Situations	189		
Capture/Compare/PWM.....	237		
CLKO and I/O	233		
Clock Synchronization	176		
Comparator Output	94		
External Clock.....	231		
Fail-Safe Clock Monitor (FSCM)	80		
I ² C Bus Data	243		
I ² C Bus Start/Stop Bits.....	242		
I ² C Reception (7-bit Address)	171		
I ² C Slave Mode (Transmission, 10-bit Address)	174		
I ² C Slave Mode with SEN = 0 (Reception, 10-bit Address).....	172		
I ² C Transmission (7-bit Address)	173		
INT Pin Interrupt.....	197		
LCD Interrupt Timing in Quarter-Duty Cycle Drive....	121		
LCD Sleep Entry/Exit when SLPEN = 1 or CS = 00 .	123		
Reset, WDT, OST and Power-up Timer	234		
Slave Synchronization	166		
SPI Master Mode (CKE = 1, SMP = 1)	240		
SPI Mode (Master Mode).....	165		
SPI Mode (Slave Mode with CKE = 0)	167		
SPI Mode (Slave Mode with CKE = 1)	167		
SPI Slave Mode (CKE = 0)	241		
SPI Slave Mode (CKE = 1)	241		
Synchronous Reception (Master Mode, SREN)	141		
Synchronous Transmission.....	139		
Synchronous Transmission (Through TXEN)	139		
Time-out Sequence			
Case 1	191		
Case 2.....	191		
Case 3.....	191		
Timer0 and Timer1 External Clock	235		
Timer1 Incrementing Edge.....	86		
Two Speed Start-up	79		
Type-A in 1/2 Mux, 1/2 Bias Drive	111		
Type-A in 1/2 Mux, 1/3 Bias Drive	113		
Type-A in 1/3 Mux, 1/2 Bias Drive	115		
Type-A in 1/3 Mux, 1/3 Bias Drive	117		
Type-A in 1/4 Mux, 1/3 Bias Drive	119		
Type-A/Type-B in Static Drive.....	110		
Type-B in 1/2 Mux, 1/2 Bias Drive	112		
Type-B in 1/2 Mux, 1/3 Bias Drive	114		

Requirements, Synchronous Receive	237
Requirements, Synchronous Transmission	237
Timing Diagram, Synchronous Receive	237
Timing Diagram, Synchronous Transmission	236
Synchronous Master Reception	140
Synchronous Master Transmission	138
Synchronous Slave Mode	141
Synchronous Slave Reception	142
Synchronous Slave Transmit	141
Transmit Data, 9th Bit (TX9D)	127
Transmit Enable (TXEN Bit)	127
Transmit Enable, Nine-bit (TX9 Bit)	127
Transmit Shift Register Status (TRMT Bit)	127

V

Voltage Reference. See Comparator Voltage Reference (CVREF)	
VRCON Register	100

W

Wake-up Using Interrupts	201
Watchdog Timer (WDT)	199
Associated Registers	200
Clock Source	199
Modes	199
Period	199
Specifications	235
WCOL bit	161
WDTCON Register	200
WPUB Register	43
Write Collision Detect bit (WCOL)	161
WWW Address	269
WWW, On-Line Support	5

PIC16F917/916/914/913

NOTES:

THE MICROCHIP WEB SITE

Microchip provides online support via our WWW site at www.microchip.com. This web site is used as a means to make files and information easily available to customers. Accessible by using your favorite Internet browser, the web site contains the following information:

- **Product Support** – Data sheets and errata, application notes and sample programs, design resources, user's guides and hardware support documents, latest software releases and archived software
- **General Technical Support** – Frequently Asked Questions (FAQ), technical support requests, online discussion groups, Microchip consultant program member listing
- **Business of Microchip** – Product selector and ordering guides, latest Microchip press releases, listing of seminars and events, listings of Microchip sales offices, distributors and factory representatives

CUSTOMER CHANGE NOTIFICATION SERVICE

Microchip's customer notification service helps keep customers current on Microchip products. Subscribers will receive e-mail notification whenever there are changes, updates, revisions or errata related to a specified product family or development tool of interest.

To register, access the Microchip web site at www.microchip.com, click on Customer Change Notification and follow the registration instructions.

CUSTOMER SUPPORT

Users of Microchip products can receive assistance through several channels:

- Distributor or Representative
- Local Sales Office
- Field Application Engineer (FAE)
- Technical Support
- Development Systems Information Line

Customers should contact their distributor, representative or field application engineer (FAE) for support. Local sales offices are also available to help customers. A listing of sales offices and locations is included in the back of this document.

Technical support is available through the web site at: <http://support.microchip.com>

In addition, there is a Development Systems Information Line which lists the latest versions of Microchip's development systems software products. This line also provides information on how customers can receive currently available upgrade kits.

The Development Systems Information Line numbers are:

1-800-755-2345 – United States and most of Canada

1-480-792-7302 – Other International Locations

PIC16F917/916/914/913

PRODUCT IDENTIFICATION SYSTEM

To order or obtain information, e.g., on pricing or delivery, refer to the factory or the listed sales office.

<u>PART NO.</u>	<u>X</u>	<u>/XX</u>	<u>XXX</u>
Device	Temperature Range	Package	Pattern
Device	PIC16F917/916/914/913 ⁽¹⁾ , PIC16F917/916/914/913T ⁽²⁾		
Temperature Range	I = -40°C to +85°C E = -40°C to +125°C		
Package	ML = Micro Lead Frame (QFN, QFN-S) P = Plastic DIP PT = TQFP (Thin Quad Flatpack) SO = SOIC SP = Skinny Plastic DIP SS = SSOP		
Pattern	3-Digit Pattern Code for QTP (blank otherwise)		

Examples:

- a) PIC16F913-E/SP 301 = Extended Temp., skinny PDIP package, 20 MHz, QTP pattern #301
- b) PIC16F913-I/SO = Industrial Temp., SOIC package, 20 MHz

Note 1: F = Standard Voltage Range
LF = Wide Voltage Range

2: T = In tape and reel.

* JW Devices are UV erasable and can be programmed to any device configuration. JW Devices meet the electrical requirement of each oscillator type.



WORLDWIDE SALES AND SERVICE

AMERICAS

Corporate Office
2355 West Chandler Blvd.
Chandler, AZ 85224-6199
Tel: 480-792-7200
Fax: 480-792-7277
Technical Support:
<http://support.microchip.com>
Web Address:
www.microchip.com

Atlanta
Alpharetta, GA
Tel: 770-640-0034
Fax: 770-640-0307

Boston
Westborough, MA
Tel: 774-760-0087
Fax: 774-760-0088

Chicago
Itasca, IL
Tel: 630-285-0071
Fax: 630-285-0075

Dallas
Addison, TX
Tel: 972-818-7423
Fax: 972-818-2924

Detroit
Farmington Hills, MI
Tel: 248-538-2250
Fax: 248-538-2260

Kokomo
Kokomo, IN
Tel: 765-864-8360
Fax: 765-864-8387

Los Angeles
Mission Viejo, CA
Tel: 949-462-9523
Fax: 949-462-9608

San Jose
Mountain View, CA
Tel: 650-215-1444
Fax: 650-961-0286

Toronto
Mississauga, Ontario,
Canada
Tel: 905-673-0699
Fax: 905-673-6509

ASIA/PACIFIC

Australia - Sydney
Tel: 61-2-9868-6733
Fax: 61-2-9868-6755

China - Beijing
Tel: 86-10-8528-2100
Fax: 86-10-8528-2104

China - Chengdu
Tel: 86-28-8676-6200
Fax: 86-28-8676-6599

China - Fuzhou
Tel: 86-591-8750-3506
Fax: 86-591-8750-3521

China - Hong Kong SAR
Tel: 852-2401-1200
Fax: 852-2401-3431

China - Shanghai
Tel: 86-21-5407-5533
Fax: 86-21-5407-5066

China - Shenyang
Tel: 86-24-2334-2829
Fax: 86-24-2334-2393

China - Shenzhen
Tel: 86-755-8203-2660
Fax: 86-755-8203-1760

China - Shunde
Tel: 86-757-2839-5507
Fax: 86-757-2839-5571

China - Qingdao
Tel: 86-532-502-7355
Fax: 86-532-502-7205

ASIA/PACIFIC

India - Bangalore
Tel: 91-80-2229-0061
Fax: 91-80-2229-0062

India - New Delhi
Tel: 91-11-5160-8631
Fax: 91-11-5160-8632

Japan - Kanagawa
Tel: 81-45-471- 6166
Fax: 81-45-471-6122

Korea - Seoul
Tel: 82-2-554-7200
Fax: 82-2-558-5932 or
82-2-558-5934

Malaysia - Penang
Tel: 011-604-646-8870
Fax: 011-604-646-5086

Philippines - Manila
Tel: 011-632-634-9065
Fax: 011-632-634-9069

Singapore
Tel: 65-6334-8870
Fax: 65-6334-8850

Taiwan - Kaohsiung
Tel: 886-7-536-4818
Fax: 886-7-536-4803

Taiwan - Taipei
Tel: 886-2-2500-6610
Fax: 886-2-2508-0102

Taiwan - Hsinchu
Tel: 886-3-572-9526
Fax: 886-3-572-6459

EUROPE

Austria - Weis
Tel: 43-7242-2244-399
Fax: 43-7242-2244-393

Denmark - Ballerup
Tel: 45-4450-2828
Fax: 45-4485-2829

France - Massy
Tel: 33-1-69-53-63-20
Fax: 33-1-69-30-90-79

Germany - Ismaning
Tel: 49-89-627-144-0
Fax: 49-89-627-144-44

Italy - Milan
Tel: 39-0331-742611
Fax: 39-0331-466781

Netherlands - Drunen
Tel: 31-416-690399
Fax: 31-416-690340

England - Berkshire
Tel: 44-118-921-5869
Fax: 44-118-921-5820

04/20/05