

# MAX809 Series, MAX810 Series

## Very Low Supply Current 3-Pin Microprocessor Reset Monitors

The MAX809 and MAX810 are cost-effective system supervisor circuits designed to monitor  $V_{CC}$  in digital systems and provide a reset signal to the host processor when necessary. No external components are required.

The reset output is driven active within 10  $\mu$ sec of  $V_{CC}$  falling through the reset voltage threshold. Reset is maintained active for a minimum of 140 msec after  $V_{CC}$  rises above the reset threshold. The MAX810 has an active-high  $\overline{\text{RESET}}$  output while the MAX809 has an active-low  $\overline{\text{RESET}}$  output. Both devices are available in a SOT-23 package.

The MAX809/810 are optimized to reject fast transient glitches on the  $V_{CC}$  line. Low supply current of 1.0  $\mu$ A ( $V_{CC} = 3.2$  V) makes these devices suitable for battery powered applications.

### Features

- Precision  $V_{CC}$  Monitor for 2.5 V, 3.0 V, 3.3 V, and 5.0 V Supplies
- Precision Monitoring Voltages from 1.6 V to 4.9 V Available in 100 mV Steps
- 140 msec Guaranteed Minimum  $\overline{\text{RESET}}$  Output Duration
- Compatible with Hot Plug Applications
- Low Supply Current
- $V_{CC}$  Transient Immunity
- Small SOT-23 Package
- No External Components
- Wide Operating Temperature:  $-40^{\circ}\text{C}$  to  $105^{\circ}\text{C}$
- Pb-Free Packages are Available

### Typical Applications

- Computers
- Embedded Systems
- Battery Powered Equipment
- Critical Microprocessor Power Supply Monitoring

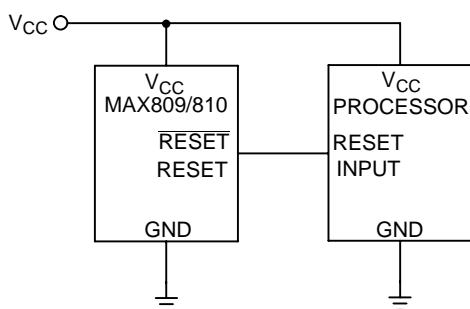

Figure 1. Typical Application Diagram



ON Semiconductor®

<http://onsemi.com>

### MARKING DIAGRAM

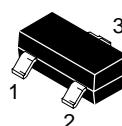

SOT-23  
(TO-236)  
CASE 318

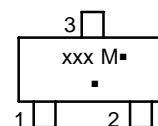

xxx = Specific Device Code  
M = Date Code  
▪ = Pb-Free Package  
(Note: Microdot may be in either location)

### PIN CONFIGURATION

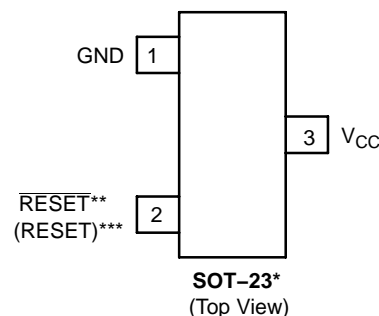

SOT-23\*  
(Top View)  
\*SOT-23 is equivalent to JEDEC (TO-236)  
\*\*  $\overline{\text{RESET}}$  is for MAX809  
\*\*\*  $\overline{\text{RESET}}$  is for MAX810

### ORDERING INFORMATION

See detailed ordering and shipping information in the package dimensions section on page 7 of this data sheet.

### DEVICE MARKING INFORMATION

See general marking information in the device marking section on page 7 of this data sheet.

# MAX809 Series, MAX810 Series

## PIN DESCRIPTION

Pin No.	Symbol	Description
1	GND	Ground
2	RESET (MAX809)	RESET output remains low while V <sub>CC</sub> is below the reset voltage threshold, and for 240 msec (Typ) after V <sub>CC</sub> rises above reset threshold
2	RESET (MAX810)	RESET output remains high while V <sub>CC</sub> is below the reset voltage threshold, and for 240 msec (Typ) after V <sub>CC</sub> rises above reset threshold
3	V <sub>CC</sub>	Supply Voltage (Typ)

## ABSOLUTE MAXIMUM RATINGS (Note 1)

Rating	Symbol	Value	Unit
Supply Voltage (V <sub>CC</sub> to GND)	V <sub>CC</sub>	6.0	V
RESET		-0.3 to (V <sub>CC</sub> + 0.3)	V
Input Current, V <sub>CC</sub>		20	mA
Output Current, RESET		20	mA
dV/dt (V <sub>CC</sub> )		100	V/μsec
Thermal Resistance, Junction-to-Air	R <sub>θJA</sub>	491	°C/W
Operating Temperature Range	T <sub>A</sub>	-40 to +105	°C
Storage Temperature Range	T <sub>stg</sub>	-65 to +150	°C
Lead Temperature (Soldering, 10 Seconds)	T <sub>sol</sub>	+260	°C
Latchup performance:	I <sub>Latchup</sub>	200 200	mA
	Positive Negative		

Maximum ratings are those values beyond which device damage can occur. Maximum ratings applied to the device are individual stress limit values (not normal operating conditions) and are not valid simultaneously. If these limits are exceeded, device functional operation is not implied, damage may occur and reliability may be affected.

1. This device series contains ESD protection and exceeds the following tests:

Human Body Model 2000 V per MIL-STD-883, Method 3015.

Machine Model Method 350 V.

2. The maximum package power dissipation limit must not be exceeded.

$$P_D = \frac{T_{J(max)} - T_A}{R_{\theta JA}} \quad \text{with } T_{J(max)} = 150^\circ\text{C}$$

## ELECTRICAL CHARACTERISTICS T<sub>A</sub> = -40°C to +105°C unless otherwise noted. Typical values are at T<sub>A</sub> = +25°C. (Note 3)

Characteristic	Symbol	Min	Typ	Max	Unit
V <sub>CC</sub> Range T <sub>A</sub> = 0°C to +70°C T <sub>A</sub> = -40°C to +105°C		1.0 1.2	- -	5.5 5.5	V
Supply Current V <sub>CC</sub> = 3.3 V T <sub>A</sub> = -40°C to +85°C T <sub>A</sub> = 85°C to +105°C V <sub>CC</sub> = 5.5 V T <sub>A</sub> = -40°C to +85°C T <sub>A</sub> = 85°C to +105°C	I <sub>CC</sub>	- -	0.5 -	1.2 2.0	μA
		- -	0.8 -	1.8 2.5	

3. Production testing done at T<sub>A</sub> = 25°C, over temperature limits guaranteed by design.

## MAX809 Series, MAX810 Series

**ELECTRICAL CHARACTERISTICS (continued)**  $T_A = -40^{\circ}\text{C}$  to  $+105^{\circ}\text{C}$  unless otherwise noted. Typical values are at  $T_A = +25^{\circ}\text{C}$ . (Note 4)

Characteristic	Symbol	Min	Typ	Max	Unit
Reset Threshold (Note 5)	$V_{TH}$				V
MAX809SN490					
$T_A = +25^{\circ}\text{C}$		4.83	4.9	4.97	
$T_A = -40^{\circ}\text{C}$ to $+85^{\circ}\text{C}$		4.78	–	5.02	
$T_A = +85^{\circ}\text{C}$ to $+105^{\circ}\text{C}$		4.66	–	5.14	
MAX8xxLTR					
$T_A = +25^{\circ}\text{C}$		4.56	4.63	4.70	
$T_A = -40^{\circ}\text{C}$ to $+85^{\circ}\text{C}$		4.50	–	4.75	
$T_A = +85^{\circ}\text{C}$ to $+105^{\circ}\text{C}$		4.40	–	4.86	
MAX809HTR					
$T_A = +25^{\circ}\text{C}$		4.48	4.55	4.62	
$T_A = -40^{\circ}\text{C}$ to $+85^{\circ}\text{C}$		4.43	–	4.67	
$T_A = +85^{\circ}\text{C}$ to $+105^{\circ}\text{C}$		4.32	–	4.78	
MAX8xxMTR					
$T_A = +25^{\circ}\text{C}$		4.31	4.38	4.45	
$T_A = -40^{\circ}\text{C}$ to $+85^{\circ}\text{C}$		4.27	–	4.49	
$T_A = +85^{\circ}\text{C}$ to $+105^{\circ}\text{C}$		4.16	–	4.60	
MAX809JTR					
$T_A = +25^{\circ}\text{C}$		3.94	4.00	4.06	
$T_A = -40^{\circ}\text{C}$ to $+85^{\circ}\text{C}$		3.90	–	4.10	
$T_A = +85^{\circ}\text{C}$ to $+105^{\circ}\text{C}$		3.80	–	4.20	
MAX8xxTTR					
$T_A = +25^{\circ}\text{C}$		3.04	3.08	3.11	
$T_A = -40^{\circ}\text{C}$ to $+85^{\circ}\text{C}$		3.00	–	3.16	
$T_A = +85^{\circ}\text{C}$ to $+105^{\circ}\text{C}$		2.92	–	3.24	
MAX8xxSTR					
$T_A = +25^{\circ}\text{C}$		2.89	2.93	2.96	
$T_A = -40^{\circ}\text{C}$ to $+85^{\circ}\text{C}$		2.85	–	3.00	
$T_A = +85^{\circ}\text{C}$ to $+105^{\circ}\text{C}$		2.78	–	3.08	
MAX8xxRTR					
$T_A = +25^{\circ}\text{C}$		2.59	2.63	2.66	
$T_A = -40^{\circ}\text{C}$ to $+85^{\circ}\text{C}$		2.56	–	2.70	
$T_A = +85^{\circ}\text{C}$ to $+105^{\circ}\text{C}$		2.49	–	2.77	
MAX809SN232					
$T_A = +25^{\circ}\text{C}$		2.28	2.32	2.35	
$T_A = -40^{\circ}\text{C}$ to $+85^{\circ}\text{C}$		2.25	–	2.38	
$T_A = +85^{\circ}\text{C}$ to $+105^{\circ}\text{C}$		2.21	–	2.45	
MAX809SN160					
$T_A = +25^{\circ}\text{C}$		1.58	1.6	1.62	
$T_A = -40^{\circ}\text{C}$ to $+85^{\circ}\text{C}$		1.56	–	1.64	
$T_A = +85^{\circ}\text{C}$ to $+105^{\circ}\text{C}$		1.52	–	1.68	
Reset Temperature Coefficient		–	30	–	ppm/ $^{\circ}\text{C}$
$V_{CC}$ to Reset Delay $V_{CC} = V_{TH}$ to $(V_{TH} - 100\text{ mV})$		–	10	–	$\mu\text{sec}$
Reset Active TimeOut Period		140	240	460	msec
RESET Output Voltage Low $V_{CC} = V_{TH} - 0.2\text{ V}$ $1.6\text{ V} \leq V_{TH} \leq 2.0\text{ V}$ , $I_{SINK} = 0.5\text{ mA}$ $2.1\text{ V} \leq V_{TH} \leq 4.0\text{ V}$ , $I_{SINK} = 1.2\text{ mA}$ $4.1\text{ V} \leq V_{TH} \leq 4.9\text{ V}$ , $I_{SINK} = 3.2\text{ mA}$	$V_{OL}$	–	–	0.3	V
RESET Output Voltage High $V_{CC} = V_{TH} + 0.2\text{ V}$ $1.6\text{ V} \leq V_{TH} \leq 2.4\text{ V}$ , $I_{SOURCE} = 200\text{ }\mu\text{A}$ $2.5\text{ V} \leq V_{TH} \leq 4.9\text{ V}$ , $I_{SOURCE} = 500\text{ }\mu\text{A}$	$V_{OH}$	$0.8 V_{CC}$	–	–	V

4. Production testing done at  $T_A = 25^{\circ}\text{C}$ , over temperature limits guaranteed by design.
5. Contact your ON Semiconductor sales representative for other threshold voltage options.

## APPLICATIONS INFORMATION

### V<sub>CC</sub> Transient Rejection

The MAX809 provides accurate V<sub>CC</sub> monitoring and reset timing during power-up, power-down, and brownout/sag conditions, and rejects negative-going transients (glitches) on the power supply line. Figure 2 shows the maximum transient duration vs. maximum negative excursion (overdrive) for glitch rejection. Any combination of duration and overdrive which lies **under** the curve will **not** generate a reset signal. Combinations above the curve are detected as a brownout or power-down. Typically, transient that goes 100 mV below the reset threshold and lasts 5.0 μs or less will not cause a reset pulse. Transient immunity can be improved by adding a capacitor in close proximity to the V<sub>CC</sub> pin of the MAX809.

maintained valid to V<sub>CC</sub> = 0 V, a pull-down resistor must be connected from  $\overline{\text{RESET}}$  to ground to discharge stray capacitances and hold the output low (Figure 3). This resistor

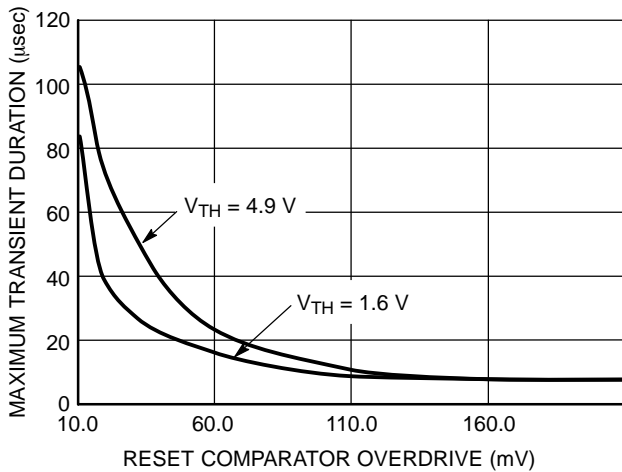
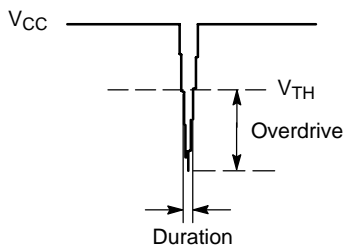

**Figure 2. Maximum Transient Duration vs. Overdrive for Glitch Rejection at 25°C**

### $\overline{\text{RESET}}$ Signal Integrity During Power-Down

The MAX809  $\overline{\text{RESET}}$  output is valid to V<sub>CC</sub> = 1.0 V. Below this voltage the output becomes an “open circuit” and does not sink current. This means CMOS logic inputs to the Microprocessor will be floating at an undetermined voltage. Most digital systems are completely shutdown well above this voltage. However, in situations where  $\overline{\text{RESET}}$  must be

# MAX809 Series, MAX810 Series

## TYPICAL CHARACTERISTICS

The following data is given for MAX809 threshold levels: 1.60 V, 2.32 V, 2.93 V, 4.63 V and 4.90 V.

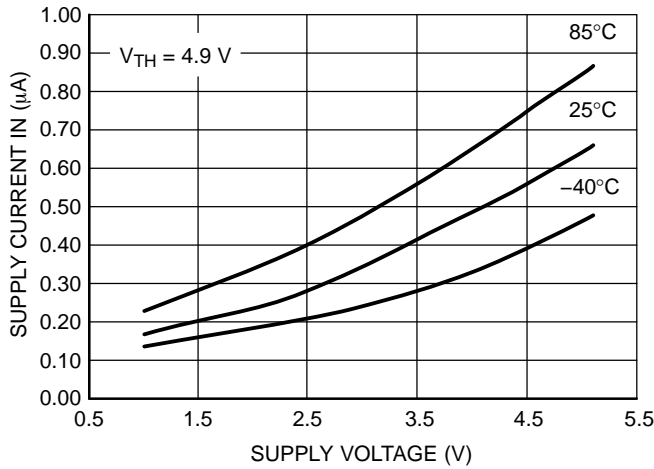

Figure 5. Supply Current vs. Supply Voltage

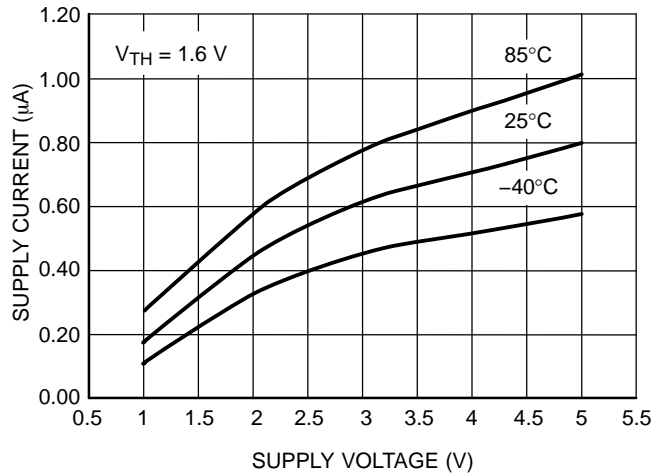

Figure 6. Supply Current vs. Supply Voltage

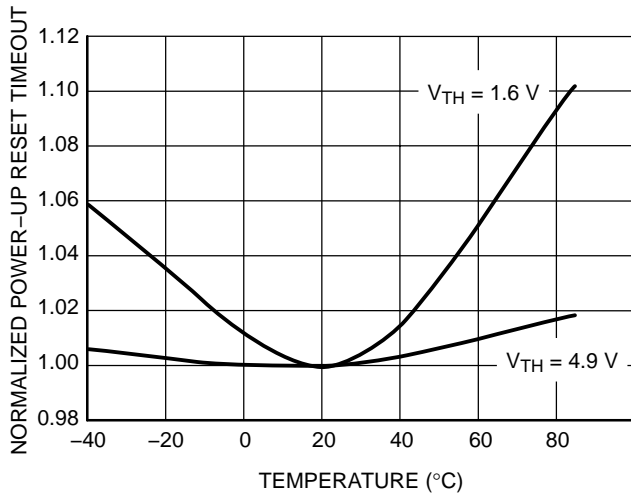

Figure 7. Normalized Power-Up Reset vs. Temperature

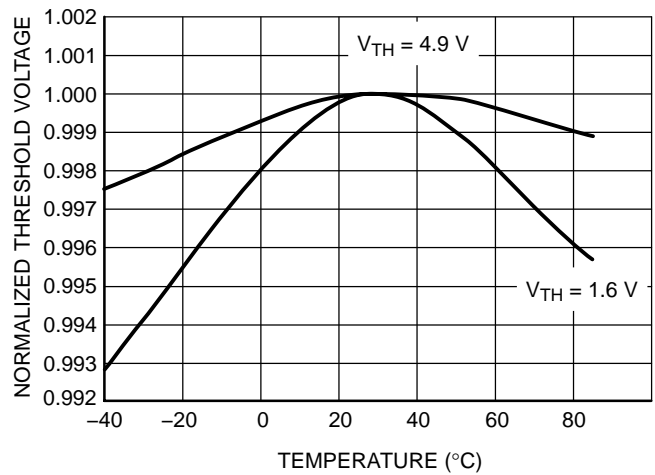
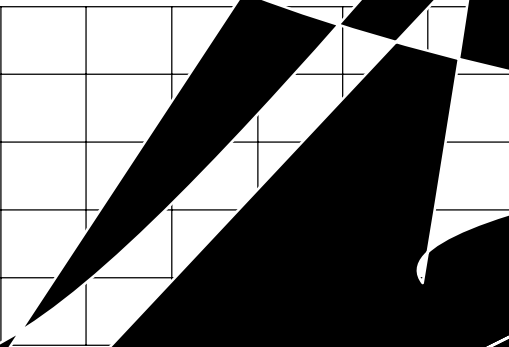
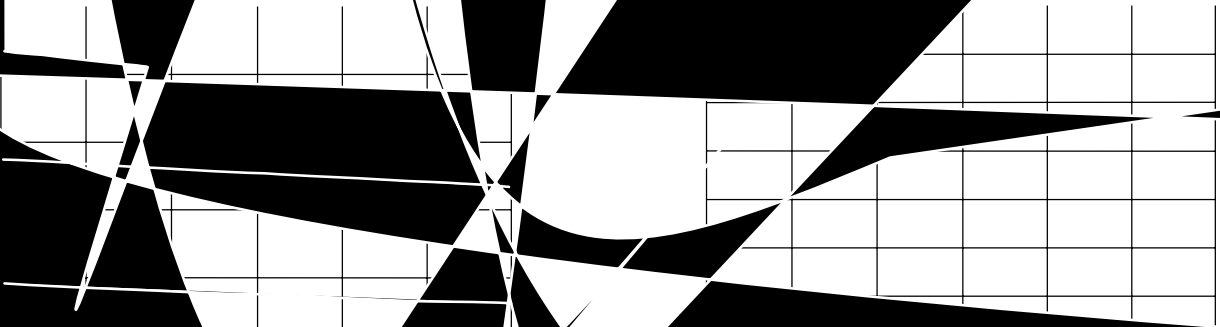
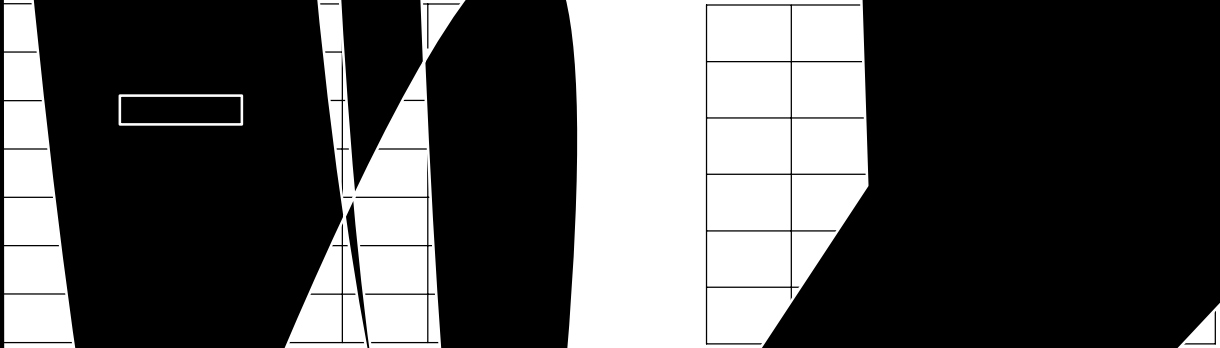

Figure 8. Normalized Reset Threshold Voltage vs. Temperature

# MAX809 Series, MAX810 Series

## TYPICAL CHARACTERISTICS

Typical data for MAX809 threshold levels: 2.63 V, 3.08 V, 4.38 V and 4.83 V  
Typical data for MAX810 threshold levels: 2.63 V, 2.93 V, 3.08 V, 4.38 V and 4.83 V



## MAX809 Series, MAX810 Series

### ORDERING, MARKING AND THRESHOLD INFORMATION

Device	V <sub>TH</sub> *	Description	Marking	Package	Shipping†
MAX809SN160T1	1.60	Push-Pull RESET	SAA	SOT-23	3000 Tape/Reel
MAX809SN160T1G	1.60		SAA	SOT-23 (Pb-Free)	
MAX809SN232T1	2.32		SQP	SOT-23	
MAX809SN232T1G	2.32		SQP	SOT-23 (Pb-Free)	
MAX809STR	2.93		SPT	SOT-23	
MAX809STRG	2.93		SPT	SOT-23 (Pb-Free)	
MAX809LTR	4.63		SPW	SOT-23	
MAX809LTRG	4.63		SPW	SOT-23 (Pb-Free)	
MAX809HTR	4.55		SBD	SOT-23	
MAX809HTRG	4.55		SBD	SOT-23 (Pb-Free)	
MAX809SN490T1	4.90		SBH	SOT-23	
MAX809SN490T1G	4.90		SBH	SOT-23 (Pb-Free)	
MAX809MTR	4.38		SPV	SOT-23	
MAX809MTRG	4.38		SPV	SOT-23 (Pb-Free)	
MAX809TTR	3.08		SPU	SOT-23	
MAX809TTRG	3.08		SPU	SOT-23 (Pb-Free)	
MAX809RTR	2.63		SPS	SOT-23	
MAX809RTRG	2.63		SPS	SOT-23 (Pb-Free)	
MAX809JTR	4.00		SPR	SOT-23	
MAX809JTRG	4.00		SPR	SOT-23 (Pb-Free)	
MAX810MTR	4.38	Push-Pull RESET	SQA	SOT-23	
MAX810MTRG	4.38		SQA	SOT-23 (Pb-Free)	
MAX810TTR	3.08		SPZ	SOT-23	
MAX810TTRG	3.08		SPZ	SOT-23 (Pb-Free)	
MAX810RTR	2.63		SPX	SOT-23	
MAX810RTRG	2.63		SPX	SOT-23 (Pb-Free)	
MAX810LTR	4.63		SQB	SOT-23	
MAX810LTRG	4.63		SQB	SOT-23 (Pb-Free)	
MAX810STR	2.93		SPY	SOT-23	
MAX810STRG	2.93		SPY	SOT-23 (Pb-Free)	

†For information on tape and reel specifications, including part orientation and tape sizes, please refer to our Tape and Reel Packaging Specifications Brochure, BRD8011/D.

\*Contact your ON Semiconductor sales representative for other threshold voltage options.

# MAX809 Series, MAX810 Series

## PACKAGE DIMENSIONS

SOT-23 (TO236)  
CASE 318-08  
ISSUE AL

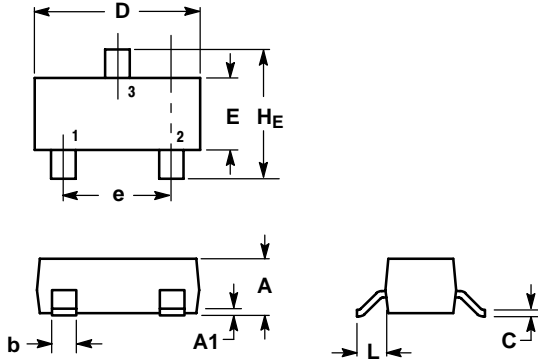

NOTES:

1. DIMENSIONING AND TOLERANCING PER ANSI Y14.5M, 1982.
2. CONTROLLING DIMENSION: INCH.
3. MAXIMUM LEAD THICKNESS INCLUDES LEAD FINISH THICKNESS. MINIMUM LEAD THICKNESS IS THE MINIMUM THICKNESS OF BASE MATERIAL.
4. 318-01 THRU -07 AND -09 OBSOLETE, NEW STANDARD 318-08.

DIM	MILLIMETERS			INCHES		
	MIN	NOM	MAX	MIN	NOM	MAX
A	0.89	1.00	1.11	0.035	0.040	0.044
A1	0.01	0.06	0.10	0.001	0.002	0.004
b	0.37	0.44	0.50	0.015	0.018	0.020
c	0.09	0.13	0.18	0.003	0.005	0.007
D	2.80	2.90	3.04	0.110	0.114	0.120
E	1.20	1.30	1.40	0.047	0.051	0.055
e	1.78	1.90	2.04	0.070	0.075	0.081
L	0.35	0.54	0.69	0.014	0.021	0.029
HE	2.10	2.40	2.64	0.083	0.094	0.104

### SOLDERING FOOTPRINT\*

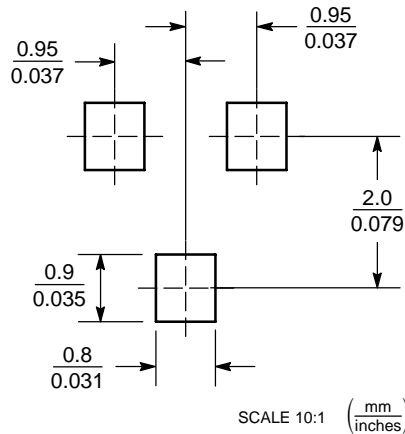

\*For additional information on our Pb-Free strategy and soldering details, please download the ON Semiconductor Soldering and Mounting Techniques Reference Manual, SOLDERRM/D.

ON Semiconductor and are registered trademarks of Semiconductor Components Industries, LLC (SCILLC). SCILLC reserves the right to make changes without further notice to any products herein. SCILLC makes no warranty, representation or guarantee regarding the suitability of its products for any particular purpose, nor does SCILLC assume any liability arising out of the application or use of any product or circuit, and specifically disclaims any and all liability, including without limitation special, consequential or incidental damages. "Typical" parameters which may be provided in SCILLC data sheets and/or specifications can and do vary in different applications and actual performance may vary over time. All operating parameters, including "Typicals" must be validated for each customer application by customer's technical experts. SCILLC does not convey any license under its patent rights nor the rights of others. SCILLC products are not designed, intended, or authorized for use as components in systems intended for surgical implant into the body, or other applications intended to support or sustain life, or for any other application in which the failure of the SCILLC product could create a situation where personal injury or death may occur. Should Buyer purchase or use SCILLC products for any such unintended or unauthorized application, Buyer shall indemnify and hold SCILLC and its officers, employees, subsidiaries, affiliates, and distributors harmless against all claims, costs, damages, and expenses, and reasonable attorney fees arising out of, directly or indirectly, any claim of personal injury or death associated with such unintended or unauthorized use, even if such claim alleges that SCILLC was negligent regarding the design or manufacture of the part. SCILLC is an Equal Opportunity/Affirmative Action Employer. This literature is subject to all applicable copyright laws and is not for resale in any manner.

### PUBLICATION ORDERING INFORMATION

**LITERATURE FULFILLMENT:**  
Literature Distribution Center for ON Semiconductor  
P.O. Box 61312, Phoenix, Arizona 85082-1312 USA  
**Phone:** 480-829-7710 or 800-344-3860 Toll Free USA/Canada  
**Fax:** 480-829-7709 or 800-344-3867 Toll Free USA/Canada  
**Email:** orderlit@onsemi.com

**N. American Technical Support:** 800-282-9855 Toll Free USA/Canada

**Japan:** ON Semiconductor, Japan Customer Focus Center  
2-9-1 Kamimeguro, Meguro-ku, Tokyo, Japan 153-0051  
**Phone:** 81-3-5773-3850

**ON Semiconductor Website:** <http://onsemi.com>

**Order Literature:** <http://www.onsemi.com/litorder>

For additional information, please contact your local Sales Representative.