

**Appliance inlet  
Type 6100-3, 6102-3**

Screw-on mounting from front or rear  
Solder terminals or Quick connect terminals  
Pin temperature 70 °C  
Protection classes I and II

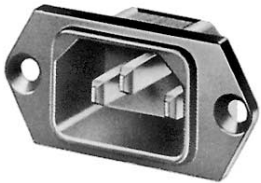

**Gerätestecker  
Typ 6100-3, 6102-3**

Schraubmontage von vorn oder hinten  
Lötanschlüsse oder Steckanschlüsse  
Stifttemperatur 70 °C  
Schutzklassen I und II

C 14 (6100) 70 °C  
C 18 (6102) 70 °C

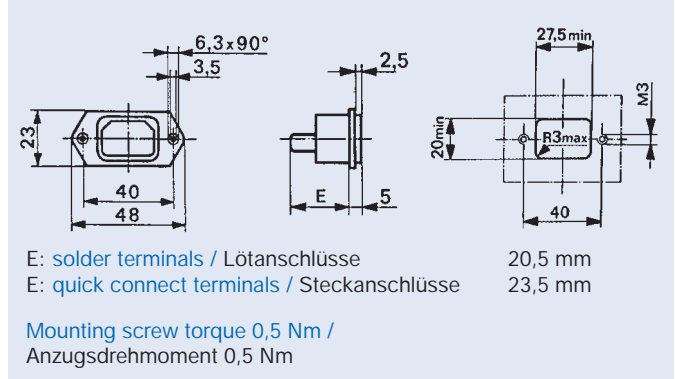
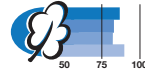

**Appliance inlet  
Type 6100-4, 6102-5**

Snap-in mounting from front  
Solder terminals or Quick connect terminals  
Pin temperature 70 °C  
Protection classes I and II



**Gerätestecker  
Typ 6100-4, 6102-5**

Schnappmontage von vorn  
Lötanschlüsse oder Steckanschlüsse  
Stifttemperatur 70 °C  
Schutzklassen I und II

C 14 (6100) 70 °C  
C 18 (6102) 70 °C

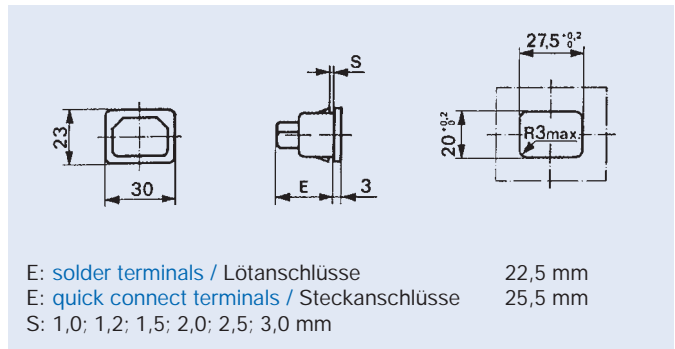
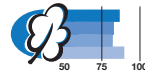

**Technical data:**

- Rated current/voltage: 10 A/250 VAC
- Insulation resistance: > 10 MΩ (500 VDC, 1 Min.)
- Dielectric strength: 2 kV (50 Hz, 1 Min.), to accessible surfaces
- Material:
  - Socket: thermoplastic, black, UL 94V-0

**Technische Daten**

- Nennstrom/Nennspannung: 10 A/250 VAC
- Isolationswiderstand: > 10 MΩ (500 VDC, 1 Min.)
- Spannungsfestigkeit: 2 kV (50 Hz, 1 Min.), zu berührbaren Oberflächen
- Material:
  - Socket: Thermoplast, schwarz, UL 94V-0

**Standards / Normen**

Protection class I / Schutzklasse I  
IEC/EN 60320-1/C14

Protection class II / Schutzklasse II  
IEC/EN 60320-1/C18

**Approvals / Approbationen**

- SEV (10 A / 250 VAC)
- VDE (10 A / 250 VAC / 6100-3/6102-3)
- VDE (10 A / 250 VAC / 6100-4/6102-5)
- SEMKO (10 A / 250 VAC)
- UL (15 A / 250 VAC)
- CSA (15 A / 250 VAC)

**Order Numbers / Bestell-Nummern**

Screw-on mounting / Schraubmontage		Snap-in mounting / Schnappmontage		Terminals / Anschlüsse
Protection class I / Schutzklasse I	Protection class II / Schutzklasse II	Protection class I / Schutzklasse I	Protection class II / Schutzklasse II	
6100.3100	6102.3100*	6100.41 XX	6102.51 XX	Solder terminals 3,5 x 0,8 mm / Lötanschlüsse 3,5 x 0,8 mm
6100.3200	6102.3200*	6100.42 XX	6102.52 XX	Quick connect terminals 4,8 x 0,8 mm / Steckanschlüsse 4,8 x 0,8 mm
6100.3300	6102.3300*	6100.43 XX	6102.53 XX	Quick connect terminals 6,3 x 0,8 mm / Steckanschlüsse 6,3 x 0,8 mm
Rivet mount types available on request Therefore change the fifth digit in the order number from a "3" to a "9" (e.g. 6100.9300) / Typen für die Nietmontage auf Anfrage erhältlich Dazu ändern Sie in der Bestell-Nr. die 5. Stelle von «3» auf «9», z.B. 6100.9300		*XX" panel thickness (s) in 1/10 mm 10, 12, 15, 20, 25, 30 e.g. 6100.4315 for 1,5 mm / «XX» Montageplattendicke (s) in 1/10 mm 10, 12, 15, 20, 25, 30 z.B. 6100.4315 für 1,5 mm		

\* Minimum order quantity for rivet mount types required / Mindestbestellmengen bei Typen für Nietmontage erforderlich

Cord retaining clamp and insulation cover see page 171 / Sicherungsbügel und Schutzabdeckung siehe Seite 171