

Product Information Bulletin

XBO[®] R 300 W/60 C

Xenon Short Arc Lamp

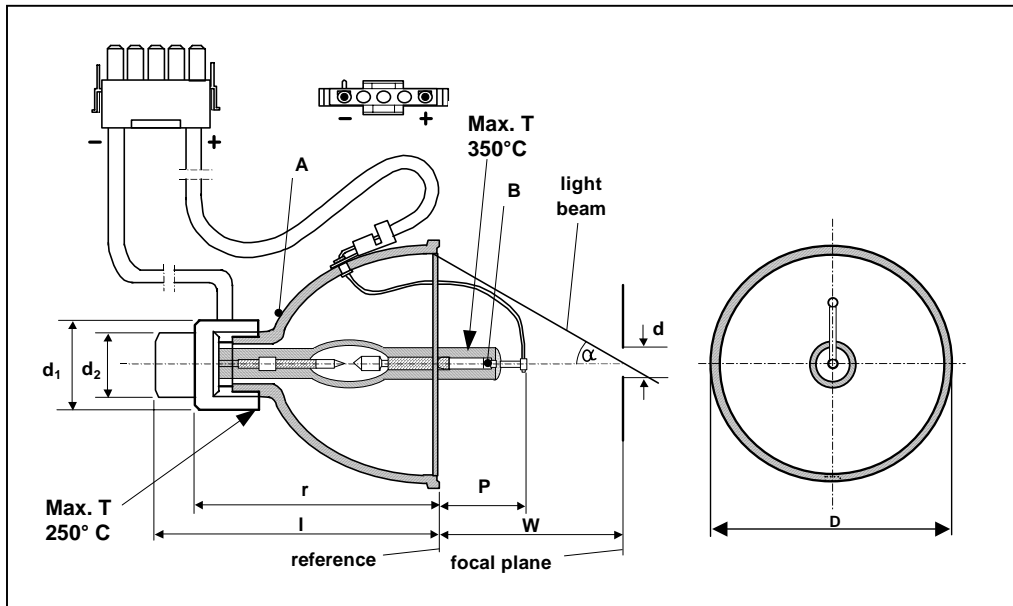

XBO R 300 W/60 C (NAED 69167) Xenon Short Arc Lamp

- Focusing elliptical reflector
- Dichroic coating for IR reduction
- Ozone-free quartz glass
- Hot restrikeable

Technical Data

Lamp / order reference (Product ordering number)	XBO R 300 W/60 C (69167)	
Electrical data:		
Rated lamp wattage	300	W
Power Operation range	200...310	W
Rated lamp current (DC)	16 (proper polarity to be observed)	A
Current control range	14...19	A
Photometric data:		
Color temperature	approx. 6,200	K
Color rendering index	CRI	>95
Geometrical data:		
Beam-to-axis angle	max. 30	deg
Length l	max. 80	mm
Length p	max. 30	mm
Length r	max. 62	mm
Reflector diameter D	max. Ø 82.5	mm
Diameter d ₁	Ø 31	mm
Diameter d ₂	Ø 23	mm
Electrical connection	approx. 120 mm long cables terminated with AMP-plug no. 350809-1, with AMP-pins no. 926868-3	
Working distance	60	mm

Other data:		
Average service life	1,000	h
Lamp operation:		
Cooling	Forced cooling	
Initial aperture lumens	<ul style="list-style-type: none"> • min. 1,450 at d = Ø 3 mm • min. 2,500 at d = Ø 5 mm 	lm
Min. individual life	500	h
Burning position	horizontal ±20° (p20)	

Electrical Data

Lamp order reference			XBO R300W/60	
Operation at constant electrical power			@ 250W	@ 300W
Voltage range of a new lamp	U_L	V	15.5 ... 18.5	16.0 ... 19.0
Reference voltage	U_{Ref}	V	17.0	17.5
Max. voltage increase in the course of lamp life	ΔU_B	V	2.5	2.5
Internal resistance (static)	R_i	Ω	0.1	0.1
Rated current	I_L	A	11.7 ... 16.5	13.7 ... 19.1
Reference current	I_{ref}	A	14.7	17.1
Maximum allowed current	I_{imax}	A	16.5	19.1
Minimum allowed current	I_{imin}	A	11.7	13.7
Maximum allowed ripple	r_{imax}	%	5	5
Rated wattage	P_L	W	250	300
Reference wattage	P_{ref}	W	250	300
Maximum allowed wattage	P_{Lmax}	W	255	305
Minimum allowed wattage	P_{Lmin}	W	245	295

Operation at constant current in the range 14...18 A

Voltage range of a new lamp	U_L	V	14...17.0
Reference voltage	U_{Ref}	V	15.5
Max. voltage increase in the course of lamp life	ΔU_B	V	2.5
Internal resistance (static)	R_i	Ω	0.1
Rated current	I_L	A	16
Reference current	I_{ref}	A	16
Maximum allowed current	I_{imax}	A	18
Minimum allowed current	I_{imin}	A	14
Maximum allowed ripple	r_{imax}	%	5
Rated wattage	P_L	W	220...270
Reference wattage	P_{ref}	W	250
Maximum allowed wattage	P_{Lmax}	W	350
Minimum allowed wattage	P_{Lmin}	W	200

Requirements for power supplies

Minimum open circuit voltage for power supplies without booster circuit

For ignition of cold lamps	U_{ok}	V	60
For ignition of cold or hot lamps	U_{oh}	V	60

No-load requirements for power supplies with booster circuit

Minimum open circuit voltage of the main rectifier	U_{oM}	V	30
Voltage of booster circuit	U_{oB}	V	100
Minimum capacitance of booster capacitor	C_B	μF	1500
Series resistance to booster capacitor	R_B	Ω	3

Alternative limits of inrush current

Maximum allowed peak of inrush current	I_{Smax}	A	40	80	160
Maximum allowed additional charge during ignition	Q_{max}	As	4.0	1.0	0.2

Requirements for igniters

Minimum peak of ignition voltage	U_{Stmin}	kV	20
Minimum pulse width at 0.9 U_{Stmin}	t_{Pmin}	μs	0.1
Load capacity range	C_Z	pF	5 ... 15
AC controlled igniters			
Minimum number of sparks per mains half-wave	F_{Zmin}		3
Minimum ignition time	T_{Zmin}	s	0.1

Application Information

Applications

- Medical and technical Fiber-Optic

Disposal

When disposing of spent lamps, always consult federal, state, local and provincial hazardous waste disposal rules and regulations to ensure proper disposal.

Operation conditions

Temperature at point A	$^{\circ}\text{C}$	max. 250 allowed; 175 - 200 optimum
Temperature at point B	$^{\circ}\text{C}$	max. 350 allowed; 200 - 250 optimum
Cooling		Forced cooling required, air flow velocity and distribution to be chosen in such a way as to ensure proper temperatures at points A and B (see drawing)

Ordering Information

Lamp Description	NAED-Code	Standard Case Quantity
XBO R300W/60 C	69167	2/case

Cooling Requirements

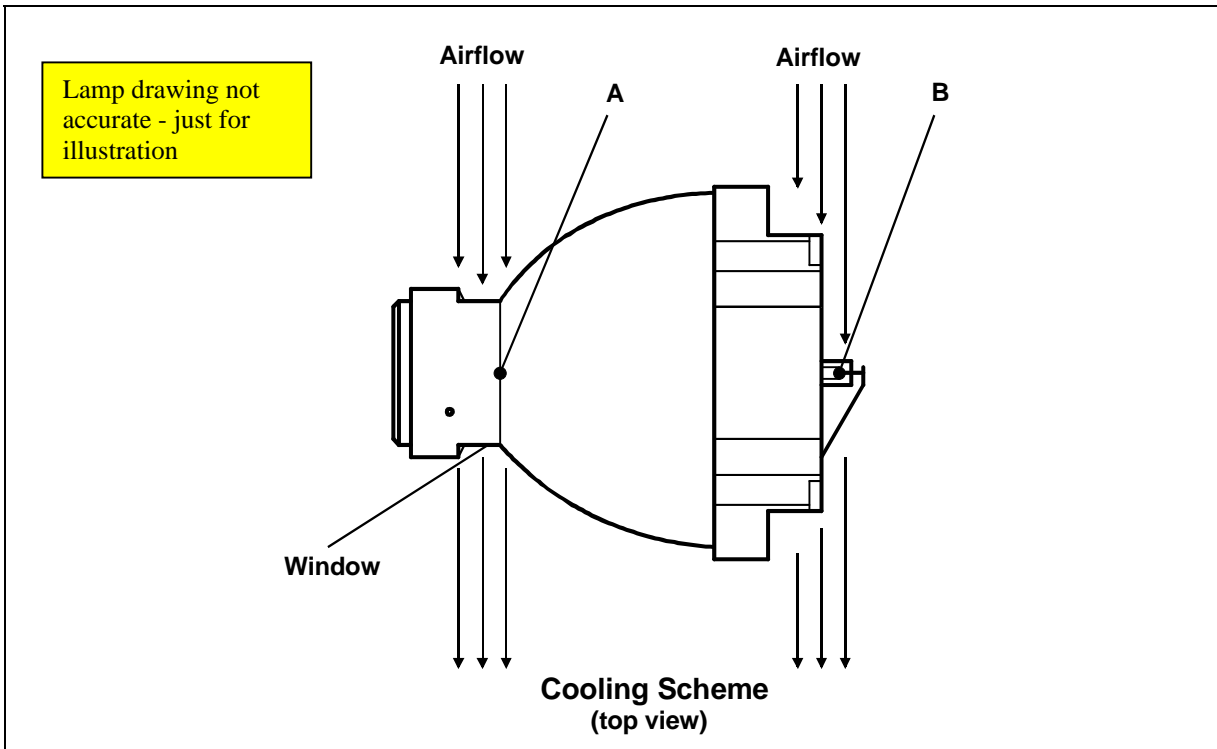

Comments

It is required that temperatures are less than 250°C at point A and 350°C at point B, respectively.

The optimum distribution and speed of airflow will depend on the design of the fixture in which a lamp is operated. Factors such as shape and volume of the fixture and position of the lamp relative to the casing or to other heat generators inside or outside the casing will all have an impact on lamp temperature.

The above suggested scheme represents just one possible solution. Any other cooling scheme can be applied as long as the temperature limits are not exceeded.

Actual temperatures can be measured with a lamp fitted with thermocouples. Lamps with thermocouples are available on request.

TYPICAL SPECTRAL DISTRIBUTION

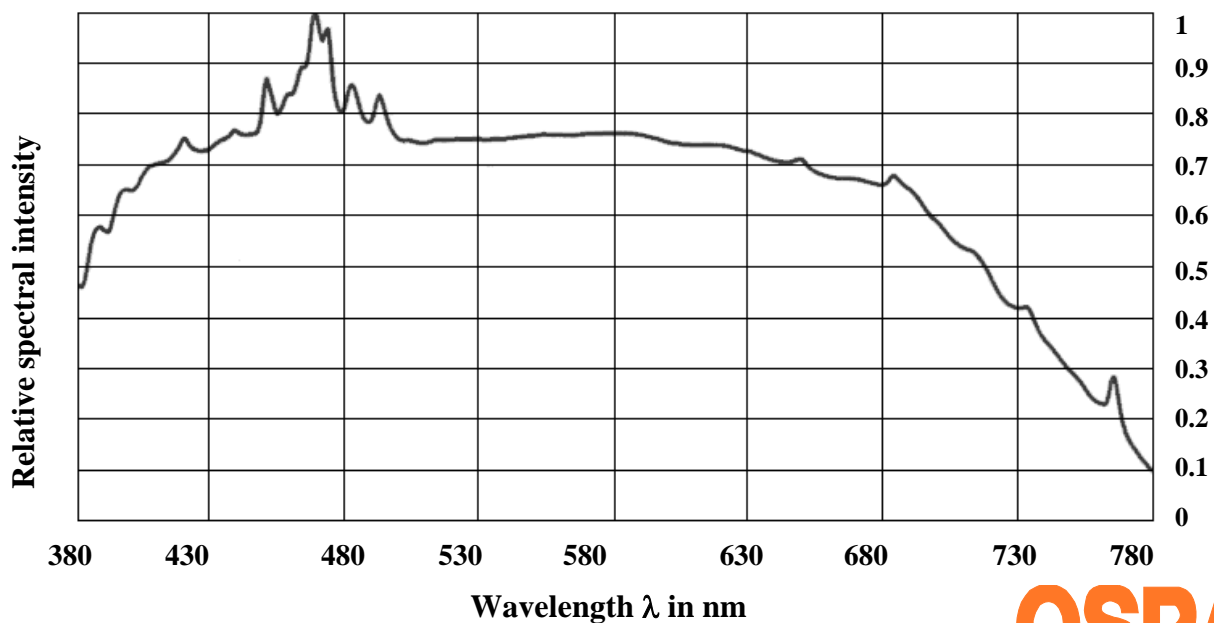

OSRAM

BEAM PROFILE AT WORKING DISTANCE

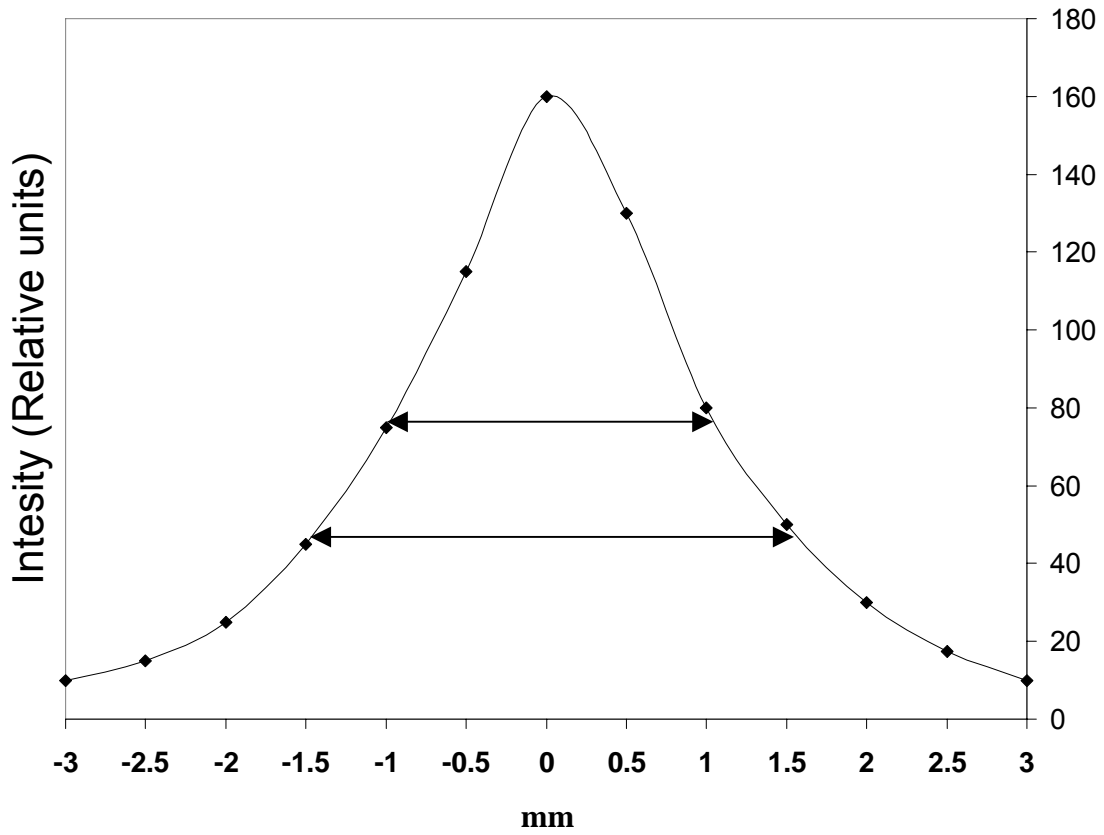

TYPICAL MAINTENANCE THROUGH 3 mm ROUND APERTURE AT WORKING DISTANCE

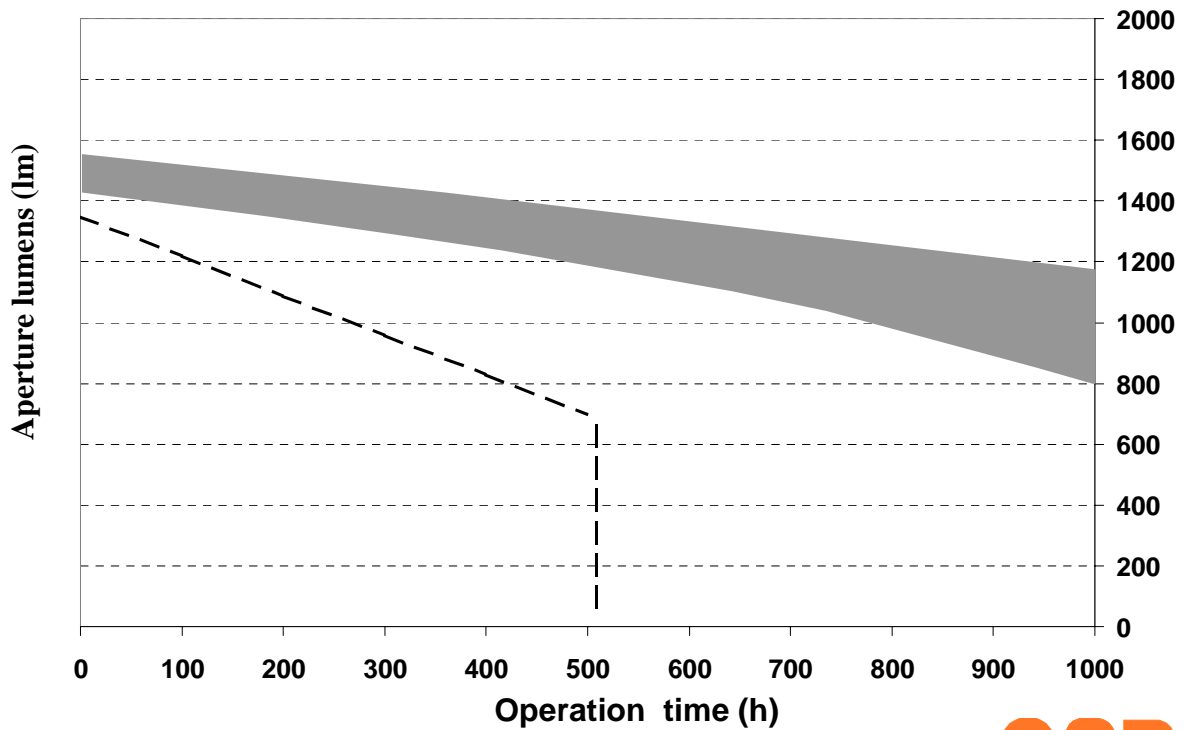

READ THIS ENTIRE STATEMENT BEFORE USING THIS LAMP.

In accordance with ANSI/IESNA Standard RP-27, XBO lamps are a Risk Group 3 product.

XBO lamps are at high internal pressure (overpressure) even in the cold (room temperature) state and must always be handled with their protective covers in place. Do not handle lamps outside of their protective covers unless OSHA-approved safety glasses, facemask (with neck protector), chest protector, and gauntlets are worn.

- This XBO lamp is constructed of quartz glass, tungsten electrodes and Molybdenum foils, and a dichroic-coated borosilicate glass reflector.
- This XBO lamp is at high internal pressure when cold (up to 35 bar or approximately 525 psi) and at operating temperature (up to 80 bar or approximately 1200 psi at bulb wall temperatures of 600°C to 800°C). **Therefore, this XBO lamp may unexpectedly rupture resulting in the discharge of hot fragments of quartz and/or glass and metal.** In the event of such a rupture, there is a risk of personal injury, burns and fire.
- Intense ultraviolet (UV), visible, and infrared (IR) radiation is also generated during operation. This radiation can cause permanent damage to the eyes (including blindness) and serious injury to the skin (including burns and blistering). This lamp uses ozonefree quartz glass (OFR) in order to prevent the generation of ozone. See the "Ozone Generation" section below.
- To avoid eye damage, other personal injury and/or property damage, the lamp MUST be operated in a suitable fixture. A suitable fixture is one that will prevent the arc from being viewed directly while operating. It is ventilated to the outside for those lamps that produce ozone and, in the event of a rupture, will prevent hot (up to 800°C), flying fragments of quartz and/or glass or metal from escaping into the surrounding area.
- To minimize the risk of a lamp rupture, the lamp must be replaced at or before the end of rated life (see catalog for rated life) or when the lamp shows signs of advanced blackening or quartz devitrification (recrystallization, a white, frosted appearance).

INSTALLATION

1. Do not use if lamp is scratched, cracked, or damaged in any way.
2. To prevent electric shock, shut off main power to the fixture before attempting to service or replace lamp.
3. To avoid damaging the quartz and causing premature lamp failure, do not handle lamp with bare hands.
4. Handle lamp ONLY with safety-appropriate, clean gloves. See special handling instructions for using OSHA-approved safety equipment with high-pressure lamps.
5. If the quartz parts or the reflector are inadvertently touched, clean fingerprints off with denatured alcohol and wipe dry with a soft, clean, lint-free cloth. Do not use cleaning rags or material that can leave a residue.
6. To prevent skin burns, allow lamp to cool before handling.
7. To avoid breakage, mounting of the lamp must be free of mechanical stress during installation and during operation by allowing for thermal expansion along its axis. For this reason, XBO lamps should be fixed at one end only and the electrical connection on the other end must be flexible enough so that no stress is placed on the lamp.
8. XBO lamps should not be subjected to force/stress during installation.
9. Handle lamp only with protective safety cover in place. When installing lamp, remove safety cover only AFTER fully securing lamp in lamphouse/fixture and immediately prec

12. Make sure lamp is properly installed into socket/connector to obtain good electrical and thermal contact and avoid damaging lamp and/or socket/connector. Electrical connections should be free from dirt and corrosion.
13. Socket/connector condition may affect lamp life. Replace socket/connector or lamp if deterioration (pitting, scorching, corrosion, etc.) of either is observed.
14. All XBO lamps are designed for DC operation. Make sure that the polarity is correct before turning power on. Incorrect polarity can destroy the lamp in a matter of seconds. Operate with compatible power supply and fixture only.
15. For best performance, operate this XBO lamp within the wattage range 250 W to 300 W.

Lamp Removal

1. Turn off power to the lamp and allow it to cool (forced or convection) for a minimum of 15 minutes prior to shutting main fixture power and opening fixture. Do not remove lamp until it has cooled. After the lamp has cooled, place the protective cover around it and reverse the procedure described above. See special handling instructions for using OSHA-approved safety equipment with high-pressure lamps.
2. Lamp should be placed in the original OSRAM SYLVANIA packaging for temporary storage until disposal and/or transportation to a disposal location. See "Lamp Disposal" section below for transportation and spent lamp disposal information.

Operating position

1. This lamp has been designed for horizontal operating position. The permissible operating position is horizontal to vertical, anode up.
2. This lamp does not require magnetic arc stabilization.

Lamp cooling

1. Discoloration, surface pitting, and/or corrosion of the lamp indicates a thermal overload. Components exhibiting these conditions must be cleaned or replaced.
2. **If forced-air cooling is used, care must be taken to direct airflow at the lamp bases only. Striking the lamp elsewhere with the airflow will result in poor lamp performance or premature failure.**
3. To prevent premature failure, the following cooling instructions must be followed:
 - The lamp base must be kept below 230°C (445°F) during operation. If convection cooling is insufficient and additional cooling is required, forced air-cooling may be used. If forced air is used, care must be taken to direct airflow at bases only, since striking elsewhere on the lamp with the airflow will result in poor lamp performance or premature failure.
 - Reflector - To avoid damaging the reflector coating, do not allow the outer reflector surface to exceed the maximum temperature of 250°C (480°F). To prevent premature failure, the non-based lamp end must not exceed the maximum temperature of 350°C (660°F). [Optimum temperature: 200-250°C (385-480°F)] Forced air-cooling is therefore required and the air flow must be directed perpendicular to the lamp/reflector axis, through the slots in the openings of both ceramics. See Product Information Bulletin for diagram.

Ozone Generation

An electrical discharge in xenon gas generates radiant energy ranging from approximately 140 nm in the UV region to far into the infrared region. Xenon lamps are made of quartz glass. The quartz glass allows for the transmission of short UV wavelengths starting from approximately 140 nm, depending on the quartz type. Ozone gas (O₃) is generated by the conversion of oxygen (O₂) in the air by UV energy in the range of approximately 110–200 nm. Ozone is extremely toxic and will cause serious health problems if inhaled in excess of allowable limits over a prolonged period of time. For more information on allowable limits, please refer to the ACGIH (American Conference of Governmental Industrial Hygienists) publication, "TLVs and BEIs" (Threshold Limit Values and Biological Exposure Indices). Ozone production can be suppressed in xenon discharge lamps by adding materials to the quartz glass that blocks short-wave UV transmission.

This lamp uses ozone-free (OFR) quartz glass that suppresses radiation below approximately 250 nm and results in the elimination of ozone production during operation.

The OSRAM logo is displayed in a bold, orange, sans-serif font.

Lamp disposal

1. There is a risk that a lamp could rupture because of its high internal pressure (both hot and at room temperature). A lamp rupture could result in personal injury or property damage from flying fragments of glass and/or metal. Therefore, spent (end-of-life) lamps should ALWAYS be stored in the protective covers and packaging in which they originally came, and ultimately de-pressurized before release for disposal. The following is one example of a de-pressurizing method for XBO lamps prior to disposal, but it may not be the most suitable or appropriate method depending on the circumstance:
 - The operator must wear OSHA-approved safety glasses, facemask (with neck protector), chest protector, and gauntlets during this entire procedure.
 - With protective lamp covers in place, place lamps¹ into steel drum² and lock down cover with bolt ring and bolt.
 - Drop drum onto solid surface (concrete floor) from at least five feet. Increase height as needed to ensure all lamps are de-pressurized.
 - Wait for dust to settle (about 5 minutes) before opening drum. Loosen bolt and allow gas to escape before complete removal of cover.

¹ The lamps should not exceed the half-full point in the drums. Adjust the maximum number of lamps accordingly.

² 8, 20, or 30-gallon drums, depending on quantity of lamps to be de-pressurized, are available. Drums of 20-gauge steel are recommended and are available from many safety supply companies.
2. Disposal of spent lamps must be in accordance with applicable federal, state/provincial, and local regulations. Some U.S. states differ in their disposal requirements.
3. Lamp users may obtain information concerning relevant agencies and disposal regulations from the Federal Superfund Hotline (Resource Conservation & Recovery Act) at 800-424-9346. Information may be available as to the appropriate state agencies to contact regarding disposal issues.
4. OSRAM SYLVANIA INC. cannot advise lamp users as to general or specific disposal regulations for federal, state/provincial, and/or local municipalities.

OSRAM SYLVANIA
National Customer Support Center
18725 N. Union Street
Westfield, IN 46074

Display/Optic

Phone: 1-888-677-2627
Phone: 1-888-OSRAMCS
Fax: 1-800-762-7192

For Orders and
General Information:
**OSRAM SYLVANIA
National Customer
Support Center**
18725 N. Union Street
Westfield, IN 46074

Photo-Optic

Phone: 1-888-677-2627
Phone: 1-888-OSRAMCS
Fax: 1-800-762-7192

Special Markets

Phone: 1-800-762-7191
Fax: 1-800-762-7192

Industrial and Commercial

Phone: 1-800-255-5042
Fax: 1-800-255-5043
Visit our website: www.sylvania.com

The OSRAM logo is displayed in a bold, orange, sans-serif font.