



PE (Polyethylene) lens



Si (Silicon) lens

FEATURES

1. Low profile achieved with fitted lens and embedded sensing circuit.

The low profile sensor (Polyethylene: 9.7mm, Silicon-lens: 6mm) is possible using Panasonic's proprietary and high-density electronic component mounting. This technology is achieved by simply embedding the sensing circuits inside the actual sensor. (See "Block Diagram" below)

With Silicon-lens sensor, the lens is incorporated in the outer package to become a pyroelectric sensor module. This makes it easy to mount the sensor on thin or compact products with limited space.

2. Motion detection with 3mm diameter miniature flat lens

A 3 mm diameter flat surface lens is possible using Panasonic's unique Lens Formation Technology for silicon substrates, making the lens operating substantially small compared to other conventional sensors.

3. 1 μ A low current consumption possible based on Panasonic's proprietary design

The development of a specialized circuit allows the reduction of current consumption to 1 μ A (*). After motion is detected, the sensor will shift to "stand-by" mode.

Reduction of Current consumption allows battery life to be extended for battery driven products. These include wireless based or energy sensitive devices.

(Note: Product lineup includes: 1 μ A, 2 μ A, and 6 μ A sensors.)

4. Robust design against false starts

Panasonic PaPIRS sensing circuits are enclosed in a metallic case which helps minimize the adverse effects of external electro magnetic fields. (i.e.: radiated noise caused by cellular phones)

Since the sensors have a high S/N ratio, they are less sensitive to false starts when operated under different environmental surroundings.

APPLICATIONS

Security & Wireless Devices

- Security sensors and cameras
- Wireless occupancy sensors driven by photovoltaic cells or battery to extend battery life.

Housing & Commercial equipment

- Lighting fixtures and wiring devices
- Video intercoms, HA control panels
- Vending machines etc.

Home appliances (Energy savings)

- Television and PC monitors
- PC, Air-Conditioners
- Air Purifiers
- Wireless and Battery operated monitoring sensing devices

What is passive infrared type?

This sensor detects changes in infrared radiation which occur when there is movement by a person (or object) which is different in temperature from the surroundings.

- 1 As this sensor detects temperature differences, it is well suited to detecting the motion of people by their body temperature.
- 2 Wide sensing area.

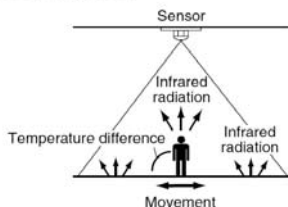

Compliance with RoHS Directive

Block Diagram

(digital output circuit)

Has a built-in amplifier and comparator connected directly to a microcomputer.

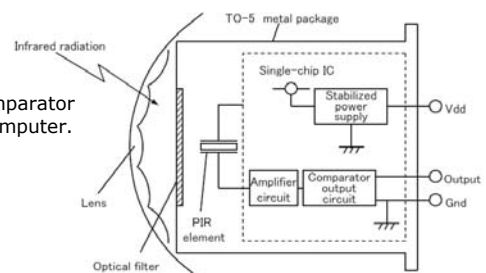

ORDERING INFORMATION

EKMA								
Output: 1: Digital								Lens Color: 0: No Lens 1: White 2: Black
Current Consumption: 1: 1 μ A 2: 2 μ A 3: 6 μ A								Lens Material: 1: Polyethylene 2: Silicon
Detection Range: 01: 5m 02: 3m								Mounting: 1: TO-5

PRODUCT TYPES

Lens type	Current Consumption	Lens color	Model No.	Inner Package	Outer Package
Si-lens type (Silicon)	1 μA	—	EKMA1102120	50pcs.	1000pcs.
	2 μA	—	EKMA1202120		
	6 μA	—	EKMA1302120		
PE-lens type (Polyethylene)	1 μA	White	EKMA1101111		
		Black	EKMA1101112		
	2 μA	White	EKMA1201111		
		Black	EKMA1201112		
	6 μA	White	EKMA1301111		
		Black	EKMA1301112		

PERFORMANCE

1. Detection Performance

Items		PE-lens type	Si-lens type	Conditions concerning the target
Detection Range *1)		Max. 5m	Max. 3m	1. The temperature difference between the target and the surroundings should be superior to 4°C.(7.2°F) 2. Movement speed: 1.0m/s 3. Target concept is human body (Size: Around 700 × 250mm)
Detection Area	Horizontal *2)	94° (±47°)	58° (±29°)	
	Vertical *2)	82° (±41°)	34° (+12° / -22°)	
	Detection Zones *3)	64 zones	4 zones	

*1) Depending on the target's speed and its temperature difference with the surroundings, detection can occur at a range superior to the above value. However, please use this sensor according to the specifications.

*2) Definitions for "Horizontal" and "Vertical"

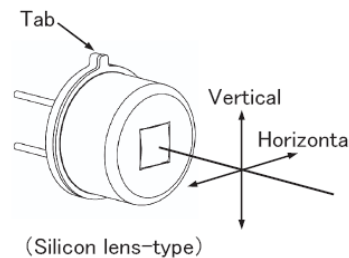
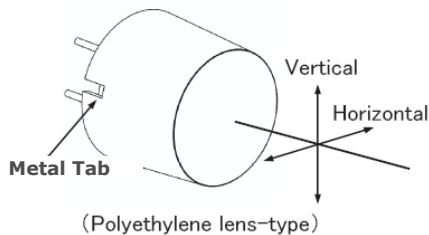

*3) Refer to the "detection area" diagram on P.4.

2. Maximum Rated Values (Common for both PE-lens type, and Si-lens type)

Items	Specified value
Power Supply Voltage	-0.3~7V DC
Usable Ambient Temperature	-20~+60°C (-4~+140°F) Do not use in a freezing or condensation environment
Storage Temperature	-20~+70°C (-4~+158°F)

3. Electrical Characteristic (Conditions for Measuring: Ambient temperature: 25° C (77° F))

Items		Symbol	1 μ A type	2 μ A type	6 μ A type	Measured Conditions
Operating Voltage	Min.	Vdd	2.3V DC	2.3V DC	2.3V	—
	Max.		6.0V DC	6.0V DC	6.0V	
Electrical Current Consumption (Sleep mode) ^(*4)	Min	Iw	1.0 μ A	—	—	Iout=0
	Max		1.6 μ A			
Electrical Current Consumption (Standby mode) ^(*5)	Avg.	Iw	1.9 μ A	1.9 μ A	6.0 μ A	Iout=0
	Max.		3.0 μ A	3.0 μ A	12.0 μ A	
Output Current	Max.	Iout	100 μ A	100 μ A	100 μ A	Vout \geq Vdd - 0.5
Output Voltage	Min.	Vout	Vdd - 0.5V DC	Vdd - 0.5V DC	Vdd - 0.5V DC	—
Circuit Stability Time (when voltage is applied)	Avg.	Twu	25s	25s	—	—
	Max.		210s	210s	30s	

(*4) (*5): "Sleep mode" or "Standby mode" is for current consumption 1 μ A type. Please refer to "TIMING CHART".

TIMING CHART

1. Digital Output (For current consumption 1 μ A)

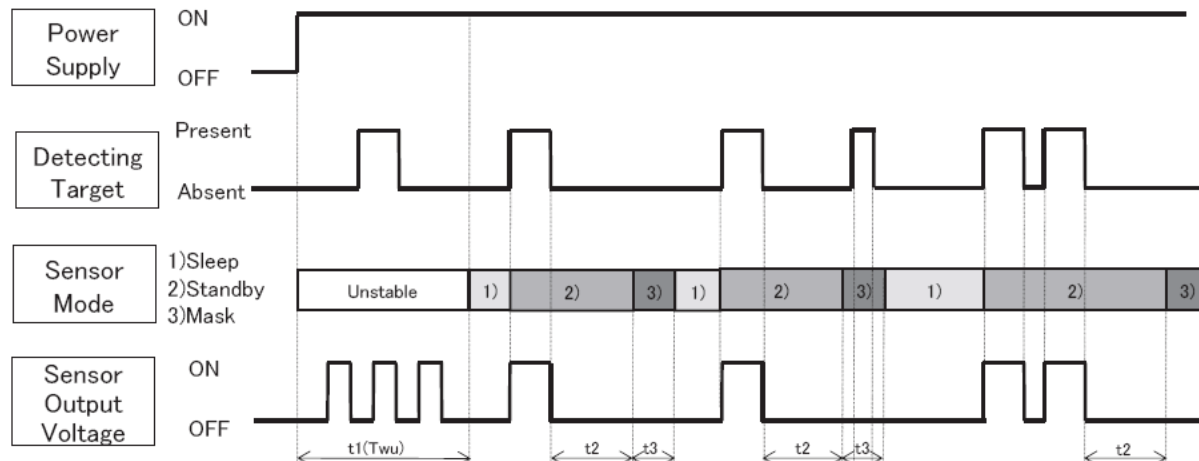

[Mode]

- 1) Sleep Mode : When the output is OFF. The electrical current consumption is around 1 μ A.
- 2) Standby Mode : After the sensor's output reached ON status, the sensor switches to standby mode. The electrical current consumption gets close to 1.9 μ A . When the sensor's output returns to its OFF value after expiration of the "hold time", the sensor switches again to sleep mode.
- 3) Mask Mode : Time during which the output is forced to OFF after the end of the standby mode. (No detection is possible during this period.)

[Duration]

- t1(Twu) : Circuit Stability Time: About 25s. (typ.)
During this stage, the output's status is undefined (ON/OFF) and detection is therefore not guaranteed.
- t2 : Standby Hold Time : About 2.6s (typ.)
Depending on the number of output happening during standby mode, the hold time can differ.
- t3 : Mask Time : About 1.3s (typ.)
During this stage, even if the sensor detects something, output will not switch to ON.

2. Digital Output (For current consumption 2 μ A and 6 μ A)

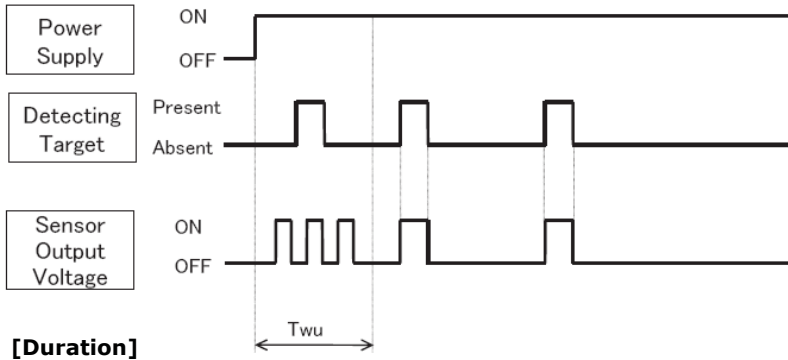

[Duration]

T_{wu} : Circuit Stability Time : About 25s. (typ.) (For 2 μ A)
 About 30s. (Max.) (For 6 μ A)

During this stage, the output's status is undefined (ON/OFF) and detection is therefore not guaranteed.

DETECTION PERFORMANCE

1. Polyethylene-lens type

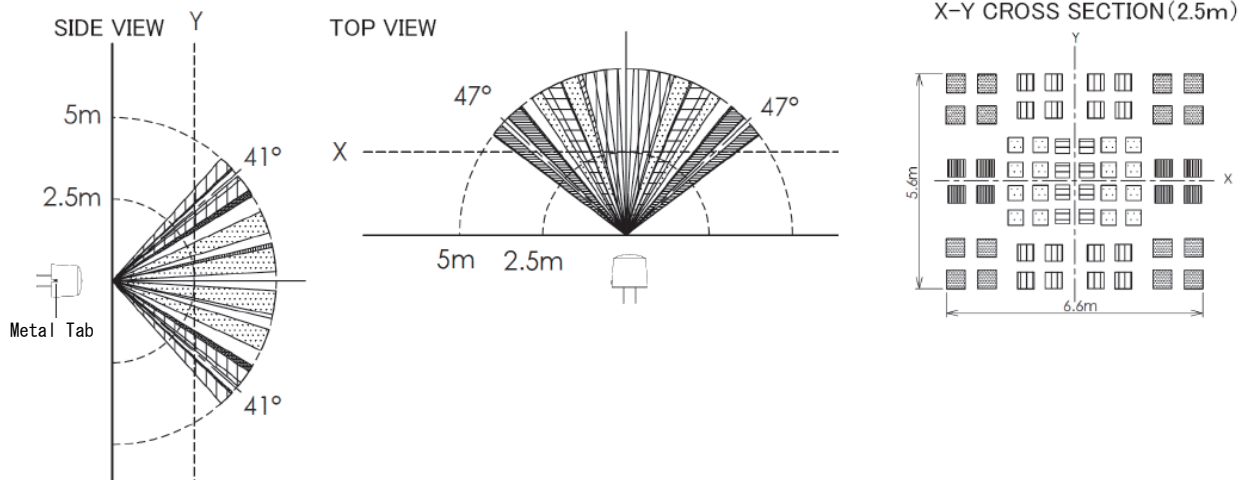

2. Silicon-lens type

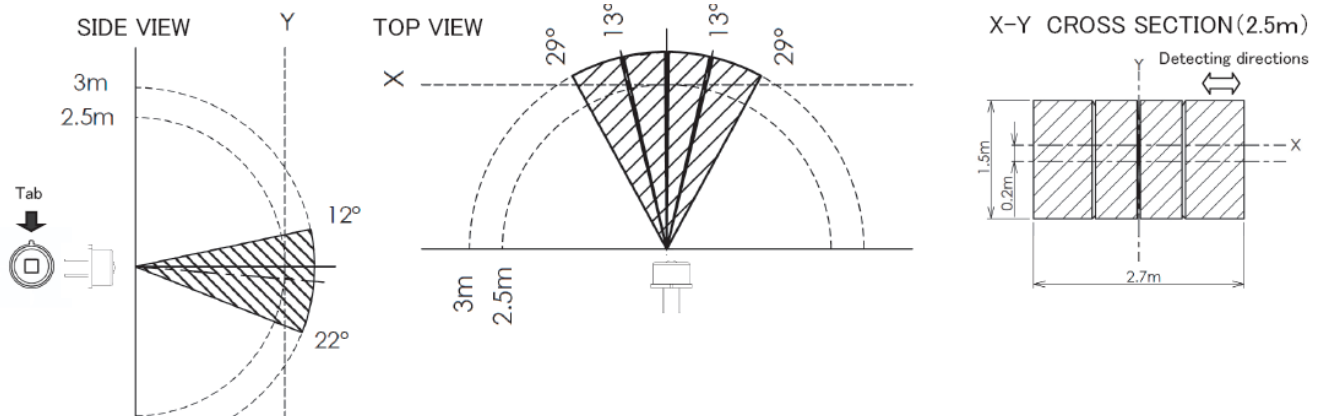

3. Notes Regarding the Detection Zone

As shown on the diagram, the detection zone is polarized. If a target enters the detection zones + and - at the same time, the signals are respectively cancelled and cannot be detected. (Please refer to the detection area diagram for details on P.4.)

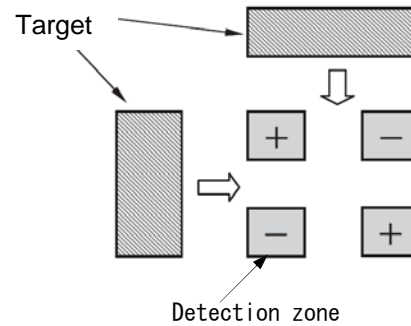

HOW TO USE

1. Wiring Diagram (Digital Output)

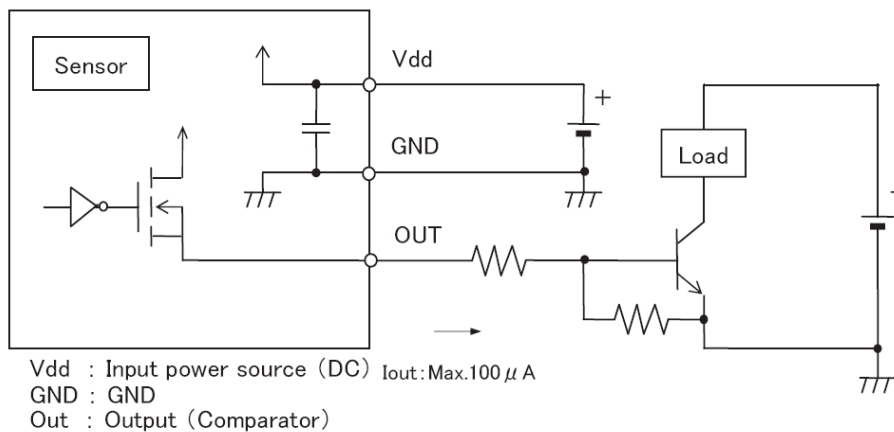

2. Moving Direction Concept

1) Polyethylene-lens type

As detailed on the diagram, please install the sensor so that the expected trespassing direction corresponds to the axis X.,Y.

In some cases, intrusions that occur parallel to the axis Z in every detection zone, closing toward the sensor, may not be detected.

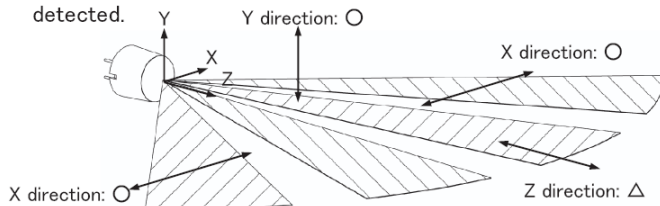

2) Silicon-lens type

As detailed on the diagram, please install the sensor so that people will be entering from the X direction.

If there will be people coming close towards the sensor from the Y or Z directions, there will be cases which people may not be detected.

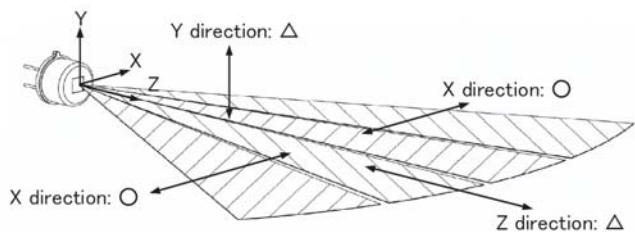

DIMENSIONS

1) Polyethylene-lens type

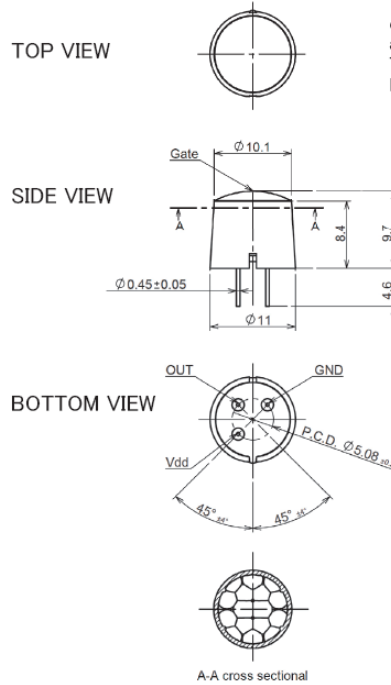

General Tolerance $\pm 0.5\text{mm}$

When designing your products

To maintain specified detection capability, please place and expose the sensor so that tip of lens will be more than 1.3mm above the chassis.

The hole of the chassis should have a taper depending on the lens shape, or have a bigger hole.

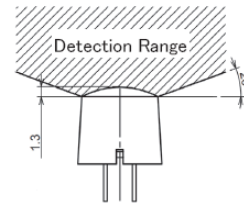

Recommended Hole Drilling Diameter

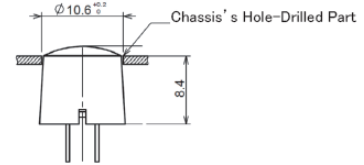

Recommended PCB Pattern Design

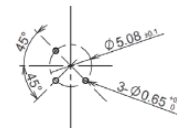

2) Silicon-lens type

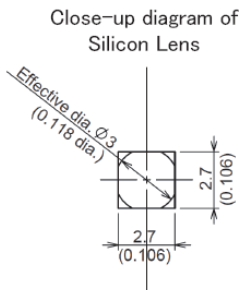
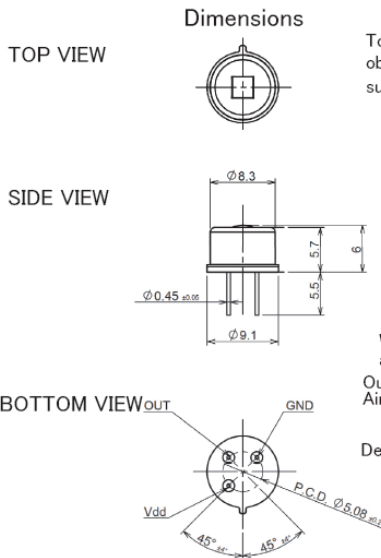

General Tolerance $\pm 0.5\text{mm}$

When designing your products

To maintain the detection performance, please avoid to place objects in the detection area of 30° left to right from the surface of the CAN.

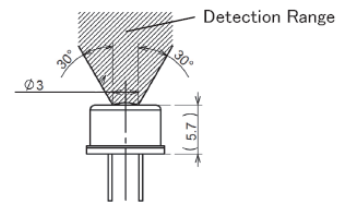

Recommended installation example

When other heat sources or in which variable temperature air streams (fan, etc.) circulates inside the device.

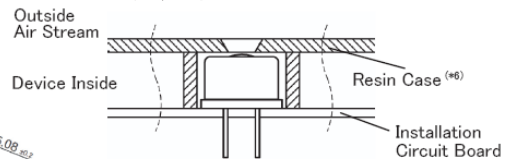

Recommended PCB Pattern Design



(*6) Metallic cases can not be used. This is because the sensor can cause operating errors due to high heat circulation inside of metallic cases and changes of ambient temperature

NOTES

1. Basic Principles

The PaPIRS Motion Sensor is a pyroelectric infrared sensor that detects variations in infrared rays. However it may not detect in the following cases: lack of movement, no temperature change in the heat source. Besides, it could also detect the presence of heat sources other than a human body. Efficiency and reliability of the system may vary depending on actual operating conditions:

- 1) Detecting heat sources other than the human body, such as:
 - a) small animals entering the detection area.
 - b) white light source (sunlight, car headlights, etc.) directly hitting the sensor.
 - c) sudden temperature changes in the detection area caused by humidifier water vapor emission, or air conditioning system hot/cold air emissions.
- 2) Difficulty in sensing the heat source
 - a) Glass, acrylic or similar materials standing between the target and the sensor may not allow a correct transmission of infrared rays.
 - b) Non-movement or quick movements of the heat source inside the detection area.
- 3) Expansion of the detection area
In case of considerable difference in the ambient temperature and the human body temperature, detection area may be wider apart from the configured detection area.

2. Other Handling Cautions

- 1) Deterioration of detecting performance will happen if dirt and dust adhere to the lens. On occasion of commodity structure design for Silicon lens type, please consider on adhesion of dirt and dust to the lens.
- 2) The lens of the Polyethylene lens type is made of soft materials (Polyethylene). If any loads or shocks are applied to the lens, due to deformities, and damages, this will lead to malfunction, or deterioration of performance. On occasion of commodity structure design for the Silicon-lens type, please consider to point of protecting the lens.
- 3) The sensor may be damaged by ± 200 volts of static electricity. Avoid direct hand contact with the pins and be very careful when operating the product
- 4) When soldering the lead wire, hand solder the sensor using the soldering iron below 350°C , and within 3 seconds. Please avoid soldering using solder tank, this can lead to deterioration of performance. Also please avoid bending the lead wire to mount the sensor on to the circuit board temporarily. This will damage the sensor.
- 5) Do not use liquids to wash the sensor. If washing fluid gets through the lens, it can reduce performance.
- 6) When wiring the product, always use shielded cables and minimize the wiring length to prevent noise disturbances.

3. Ambient Environmental Conditions

- 1) Temperature : Ambient Temperature $-20^{\circ}\text{C} \sim +60^{\circ}\text{C}$ ($-4^{\circ}\text{F} \sim +140^{\circ}\text{F}$)
(Do not use in a freezing or condensation environment)
Storage Temperature $-20^{\circ}\text{C} \sim +70^{\circ}\text{C}$ ($-4^{\circ}\text{F} \sim +158^{\circ}\text{F}$)
- 2) Humidity Degree : $15 \sim 85\%$ Rh (Avoid condensation or freezing of this product)
- 3) Pressure : $86 \sim 106\text{kPa}$
- 4) Operating "temperatures" and "humidity level" are suggested to prolong usage. However, they do not guarantee durability or environmental resistance. Generally, high temperatures or high humidity levels will accelerate the deterioration of electrical components. Please consider both the planned usage and environment to determine the expected reliability and length of life of the product.
- 5) This sensor is not waterproof or dustproof. Avoid use in environments subject to excessive moisture, condensation, frost, containing salt air or dust. If a sensor is used with a cover installed, the initial detection performance specifications may not be able to be met. Confirm the operation under the actual operating conditions.
- 6) Overheating, oscillations, shocks can cause the sensor to malfunction.

4. External surge voltages

The inner circuit board could be destroyed by a voltage surge. Use of surge absorption elements is highly recommended.

>Surge resistance : below the power supply voltage value indicated in the maximum rated values section.

5. Power supply-superimposed noise

1) Please use a stabilized power supply. Power supply noise can cause operating errors.

>Noise resistance : ± 20 V or less (Square waves with a width of 50ns or 1 μ s)

2) To reduce the effect of power supply noise, install a capacitor on the sensor's power supply pin.

6. Drop damage

After the sensor had been dropped on the floor, the damage can occur resulting in incorrect operation.

Therefore, be sure not to use those sensors.

**Safety Precautions**

Head the following precautions to prevent injury or accidents.

- Do not use these sensors under any circumstance in which the range of their ratings, environment conditions or other specifications are exceeded. Using the sensors in any way which causes their specifications to be exceeded may generate abnormally high levels of heat, emit smoke, etc., resulting in damage to the circuitry and possibly causing an accident.
- Before connecting, check the pin layout by referring to the connector wiring diagram, specifications diagram, etc., to verify that the connector is connected properly. Mistakes made in connection may cause unforeseen problems in operation, generate abnormally high levels of heat, emit smoke, etc., resulting in damage to the circuitry.
- Do not use any motion sensor which has been disassembled or remodeled.
- Failure modes of sensors include short-circuiting, open-circuiting and temperature rises. If this sensor is to be used in equipment where safety is a prime consideration, examine the possible effects of these failures on the equipment concerned, and ensure safety by providing protection circuits or protection devices.

Example :

- Safety equipments and devices
- Traffic signals
- Burglar and disaster prevention