

**2N3866 / 2N3866A**

**RF & MICROWAVE DISCRETE  
 LOW POWER TRANSISTORS**

**Features**

- Silicon NPN, To-39 packaged VHF/UHF Transistor
- Specified 400 MHz, 28Vdc Characteristics
  - Output Power = 1.0 Watt
  - Minimum Gain = 10 dB
  - Efficiency = 45%
- 800 MHz Current-Gain Bandwidth Product

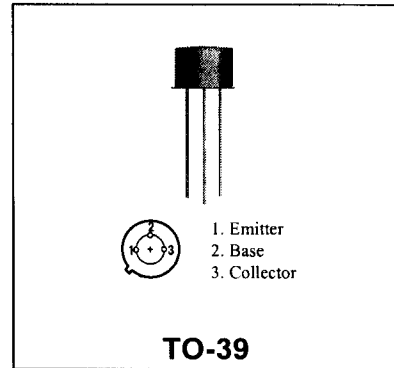

**DESCRIPTION:**

Silicon NPN transistor, designed for VHF and UHF equipment. Applications include amplifier; pre-driver, driver, and output stages. Also suitable for oscillator and frequency-multiplier functions.

**ABSOLUTE MAXIMUM RATINGS (T<sub>case</sub> = 25°C)**

Symbol	Parameter	Value	Unit
V <sub>CEO</sub>	Collector-Emitter	30	Vdc
V <sub>CBO</sub>	Collector-Base Voltage	55	Vdc
V <sub>EBO</sub>	Emitter-Base Voltage	3.5	Vdc
I <sub>c</sub>	Collector Current	400	mA

**Thermal Data**

P <sub>D</sub>	Total Device Dissipation Derate above 25°C	5.0 28.6	Watts mW/ °C
----------------	---	-------------	-----------------

ELECTRICAL SPECIFICATIONS (Tcase = 25°C)

**STATIC**  
**(off)**

Symbol	Test Conditions	Value			Unit
		Min.	Typ.	Max.	
BVCER	Collector-Emitter Breakdown Voltage (IC = 5.0 mAdc, RBE = 10 ohms)	55	-	-	Vdc
BVCEO	Collector-Emitter Sustaining Voltage (IC=5.0 mAdc, IB=0)	30	-	-	Vdc
BVCBO	Collector-Base Breakdown Voltage (IE = 0, IC = 0.1 mAdc)	55	-	-	Vdc
BVEBO	Emitter-Base Breakdown Voltage (IE = 0.1 mAdc, IC = 0)	3.5	-	-	Vdc
ICEO	Collector Cutoff Current (VCE = 28 Vdc, IB = 0)	-	-	20	μA
ICEX	Collector Cutoff Current (VCE = 55 Vdc, VBE = 1.5 Vdc)	-	-	100	μA

**(on)**

HFE	DC Current Gain (IC = 360 mAdc, VCE = 5.0 Vdc) Both	5.0	-	-	-
	(IC = 50 mAdc, VCE = 5.0 Vdc) 2N3866	10	-	200	-
	(IC = 50 mAdc, VCE = 5.0 Vdc) 2N3866A	25	-	200	-
VCE(sat)	Collector-Emitter Saturation Voltage (IC = 100 mAdc, IB = 20 mAdc)	-	-	1.0	Vdc

**DYNAMIC**

Symbol	Test Conditions	Value			Unit	
		Min.	Typ.	Max.		
f <sub>T</sub>	Current-Gain - Bandwidth Product (IC = 50 mAdc, VCE = 15 Vdc, f = 200 MHz)	2N3866	500	800	-	MHz
		2N3866A	800	-	-	
COB	Output Capacitance (VCB = 30 Vdc, IE = 0, f = 1.0 MHz)	-	2.8	3.5	pF	

**FUNCTIONAL**

Symbol	Test Conditions		Value			Unit
			Min.	Typ.	Max.	
$G_{PE}$	Power Gain	Test Circuit-Figure 1 Pin = 0.1 W, VCE = 28Vdc f = 400 MHz, TC = 25 C	10	-	-	dB
$P_{out}$	Output Power	Test Circuit-Figure 1 Pin = 0.1 W, VCE = 28Vdc f = 400 MHz, TC = 25 C	1.0	-	-	Watts
$\eta_c$	Collector Efficiency	Test Circuit-Figure 1 Pin = 0.1 W, VCE = 28Vdc f = 400 MHz, TC = 25 C	45	-	-	%

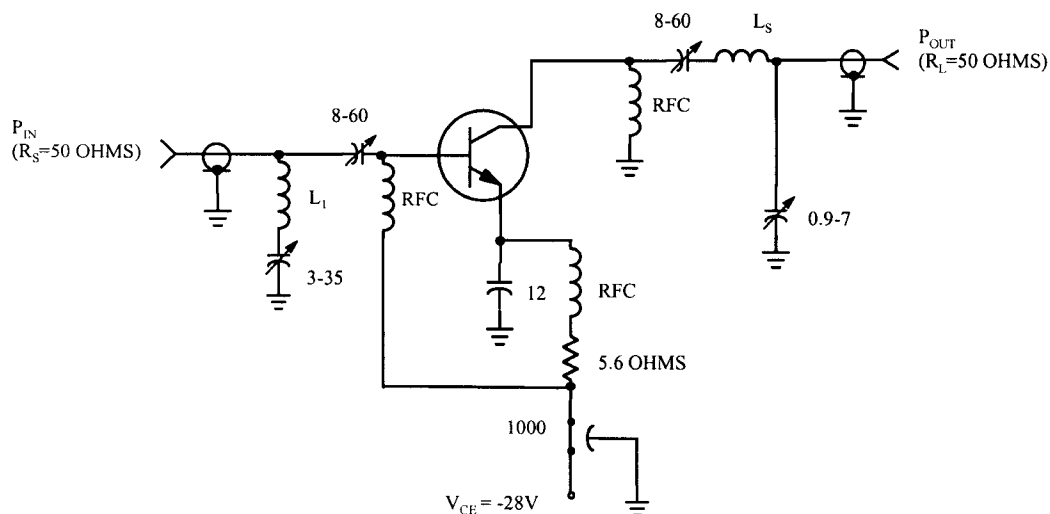

**Figure 1 - 400 MHz RF AMPLIFIER CIRCUIT FOR  $G_{PE}$ ,  $P_{OUT}$ , AND EFFICIENCY SPECIFICATIONS.**

$L_1$ : 2 TURNS No. 18 wire, 1/4" ID, 1/8" long

$L_s$ : 2 3/4 TURNS No. 18 wire, 1/4" ID, 3/16" long

Capacitor values in pF unless otherwise indicated.

Tuning capacitors are air variable

**2N3866 / 2N3866A**

**RF Low Power PA, LNA, and General Purpose Discrete Selector Guide**

Packag	Device	Type	GPE Freq (MHz)	Pout	GPE (dB)	Efficiency (%)	GPE VCC	BVCEO	IC max (mA)
SO-8	MRF4427, R2	NPN	175	0.15	18	60	12	20	400
TO-39	2N4427	NPN	175	1	10	50	12	20	400
POWER MACRO	MRF553	NPN	175	1.5	11.5	60	12.5	16	500
POWER MACRO	MRF553T	NPN	175	1.5	11.5	50	12.5	16	500
TO-39	MRF607	NPN	175	1.75	11.5	50	12.5	16	330
TO-39	2N6255	NPN	175	3	7.8	50	12.5	18	1000
TO-72	2N5179	NPN	200		20		6	12	50
MACRO X	MRF559	NPN	512	0.5	10	65	7.5	16	150
MACRO X	MRF559	NPN	512	0.5	13	60	12.5	16	150
TO-39	2N3866A	NPN	400	1	10	45	28	30	400
SO-8	MRF3866, R1, R2	NPN	400	1	10	45	28	30	400
POWER MACRO	MRF555	NPN	470	1.5	11	50	12.5	16	400
POWER MACRO	MRF555T	NPN	470	1.5	11	50	12.5	16	400
MACRO X	MRF559	NPN	870	0.5	6.5	70	7.5	16	150
MACRO X	MRF559	NPN	870	0.5	9.5	65	12.5	16	150
SO-8	MRF8372, R1, R2	NPN	870	0.75	8	55	12.5	16	200
POWER MACRO	MRF557	NPN	870	1.5	8	55	12.5	16	400
POWER MACRO	MRF557T	NPN	870	1.5	8	55	12.5	16	400

Packag	Device	Type	Freq (MHz)	NF (dB)	NF IC (mA)	NF VCE	GNF (dB)	Gu Max (dB)	Ftau (MHz)	Ccb(pF)	BVCEO	IC max (mA)
TO-39	2N5109	NPN	200	3	10	15		12	1200	3.5	20	400
TO-39	MRF5943C	NPN	200	3.4	30	15		11.4	1000		30	400
SO-8	MRF5943, R1, R2	NPN	200	3.4	30	15		15	1300		30	400
TO-72	2N5179	NPN	200	4.5	1.5	8		17	800	1	12	50
TO-72	2N2857	NPN	300	5.5	50	8		13	1600	1	15	40
TO-39	MRF517	NPN	300	7.5	50	15		5.5	4600	3	25	150
TO-72	MRF904	NPN	450	1.5	5	8		11	4000	1	15	30
TO-72	2N6304	NPN	450	5	2	5		14	1400	1	15	50
MACRO T	BFR91	NPN	500	1.9	2	5	11	16.5	5000	1	12	35
MACRO T	BFR96	NPN	500	2	10	10		14.5	500	2.6	15	100
SO-8	MRF5812, R1, R2	NPN	500	2	50	10	15.5	17.8	5000		15	200
MACRO X	MRF581A	NPN	500	2	50	10	14	15	5000		15	200
Macro	BFR90	NPN	500	2.4	2	10	15	18	5000	1	15	30
TO-72	BFR90	NPN	500	2.5	2	5	20	1300		15	50	
TO-72	MRF914	NPN	500	2.5	5	10		15	4500		12	40
MACRO X	MRF581	NPN	500	2.5	50	10	15	17.8	5000		16	200
TO-39	MRF588	NPN	500	3	80	15	11	14.5	4500	2.2	17	200
MACRO X	MRF551	NPN	1000	1.3	5	8	14	17	8000	0.45	10	100
MACRO X	MRF571	NPN	1000	1.5	10	8	10		8000	1	10	70
MACRO T	BFR91	NPN	1000	2.5	2	5	8	11	5000	1	12	35
MACRO T	BFR90	NPN	1000	3	2	10	10	12.5	5000	1	15	30
TO-39	MRF545	PNP						14	1400	2	70	400
TO-39	MRF544	NPN						13.5	1500		70	400

RF (Low Power PA / General Purpose) Selection

RF (LNA / General Purpose) Selection Guide

**Low Cost RF Plastic Package Options**

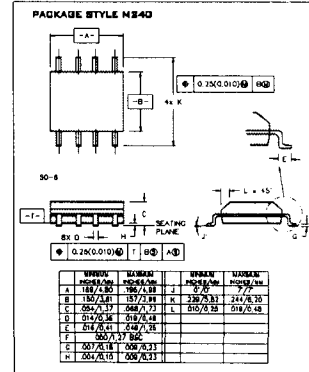
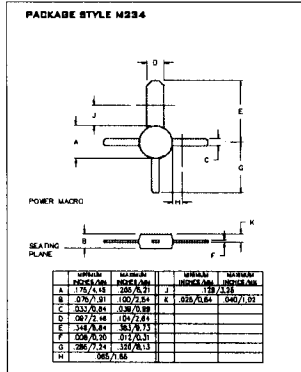
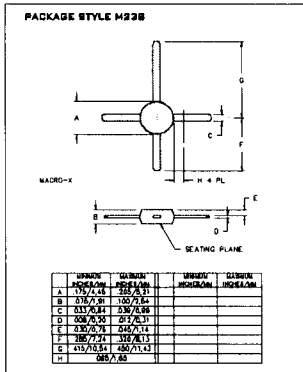
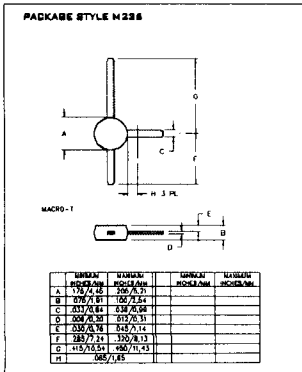

Macro T

Macro X

Power

SO-8

**PACKAGE STYLE M246**

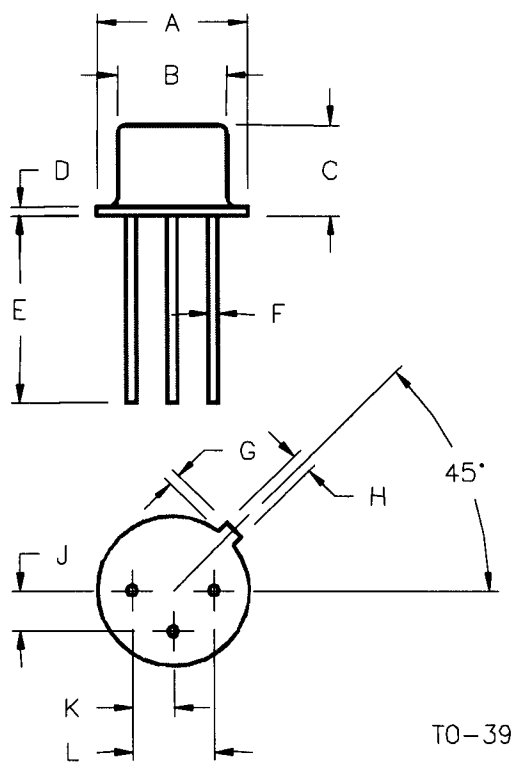

	MINIMUM INCHES/MM	MAXIMUM INCHES/MM		MINIMUM INCHES/MM	MAXIMUM INCHES/MM
A	.350/8,89	.370/9,40	J	.095/2,41	.105/2,67
B	.315/8,00	.335/8,51	K	.095/2,41	.105/2,67
C	.240/6,10	.260/6,60	L	.190/4,83	.210/5,33
D	.015/0,38	.045/1,14			
E	.500/12,70				
F	.016/0,41	.019/0,48			
G	.029/0,74	.040/1,02			
H	.028/0,71	.034/0,86			