

**Passende Flachstecker,  
2,8 mm x 0,8 mm,  
mit symmetrischer  
Stahlüberfeder**

**Ausdrückwerkzeug:**  
Best.-Nr. 726548-1

**Siehe Tabellenzeichnung:**  
87-9441-16

**Produkt-Spezifikation:**  
108-18063

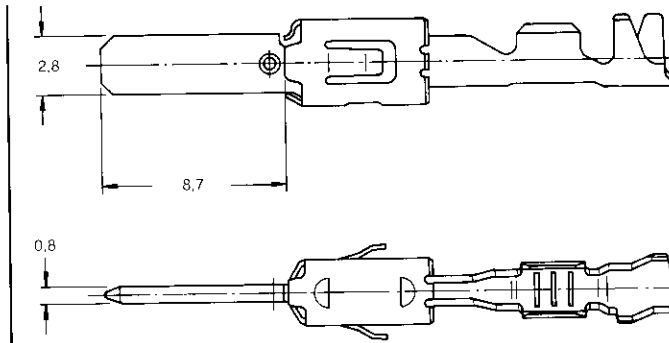

**Mating Tabs,  
2.8 mm x 0.8 mm,  
with Symmetric  
Cantilever Steel Spring**

**Extraction Tool:**  
Part No. 726548-1

**See Chart-Drawing:**  
87-9441-16

**Product Specification:**  
108-18063

**Flachstecker**

**Tab**

Leiterquer- schnittsbereich Wire Size Range (mm <sup>2</sup> )	Isolierungsdurchmesser (max.) Insulation Diameter (max.) (mm)		Material und Oberfläche Material and Finish	Bestell-Nummern/Part Numbers			Handzange Hand Tool
	FLK	FLR		Band- ausführung Strip Form	Einzel- ausführung Loose-Piece	Anschlag- werkzeug Applicator	
0,2-0,5	-	1,2-1,6	CuSn, Kontaktkörper vorvergoldet über Ni, Kontaktzone vorvergoldet min. 0,6 µm CuSn, contact body pre-gold plated over nickel, contact area pre-gold plated min. 0.6 µm	1-963860-3	1-963861-3	2-878549-2	734538-1
0,2-0,5	-	1,2-1,6	CuSn, versilbert/CuSn, silver plated	1-963860-2	1-963861-2	2-878549-2	734538-1
0,2-0,5	-	1,2-1,6	CuSn, vorverzinkt/CuSn, pre-tin plated	1-963860-1	1-963861-1	2-878549-2	734538-1
0,2-0,5	-	1,2-1,6	CuFe, Kontaktkörper vorvergoldet über Ni, Kontaktzone vorvergoldet min. 0,6 µm CuFe, contact body pre-gold plated over nickel, contact area pre-gold plated min. 0.6 µm	2-963860-3	2-963748-3	2-878549-2	734538-1
0,2-0,5	-	1,2-1,6	CuFe, versilbert/CuFe, silver plated	2-963860-2	2-963748-2	2-878549-2	734538-1
0,2-0,5	-	1,2-1,6	CuFe, vorverzinkt/CuFe, pre-tin plated	2-963860-1	2-963748-1	2-878549-2	734538-1

**Flachstecker**

**Tab**

Leiterquer- schnittsbereich Wire Size Range (mm <sup>2</sup> )	Isolierungsdurchmesser (max.) Insulation Diameter (max.) (mm)		Material und Oberfläche Material and Finish	Bestell-Nummern/Part Numbers			Handzange Hand Tool
	FLK	FLR		Band- ausführung Strip Form	Einzel- ausführung Loose-Piece	Anschlag- werkzeug Applicator	
0,5-1,0	-	1,4-2,1	CuFe, Kontaktkörper vorvergoldet über Ni, Kontaktzone vorvergoldet min. 0,6 µm CuFe, contact body pre-gold plated over nickel, contact area pre-gold plated min. 0.6 µm	2-962841-3	2-963745-3	2-878550-2	734417-1
0,5-1,0	-	1,4-2,1	CuFe, versilbert/CuFe, silver plated	2-962841-2	2-963745-2	2-878550-2	734417-1
0,5-1,0	-	1,4-2,1	CuFe, vorverzinkt/CuFe, pre-tin plated	2-962841-1	2-963745-1	2-878550-2	734417-1
0,5-1,0	-	1,4-2,1	CuSn, Kontaktkörper vorvergoldet über Ni, Kontaktzone vorvergoldet min. 0,6 µm CuSn, contact body pre-gold plated over nickel, contact area pre-gold plated min. 0.6 µm	1-962841-3	1-963745-3	2-878550-2	734417-1
0,5-1,0	-	1,4-2,1	CuSn, versilbert/CuSn, silver plated	1-962841-2	1-963745-2	2-878550-2	734417-1
0,5-1,0	-	1,4-2,1	CuSn, vorverzinkt/CuSn, pre-tin plated	1-962841-1	1-963745-1	2-878550-2	734417-1

**Einzelichtungssystem**

**Single Sealing System**

Leiterquer- schnittsbereich Wire Size Range (mm <sup>2</sup> )	Isolierungsdurchmesser (max.) Insulation Diameter (max.) (mm)		Material und Oberfläche (siehe Hinweis) Material and Finish (see Note)	Bestell-Nummern/Part Numbers			Handzange Hand Tool
	FLK	FLR		Band- ausführung Strip Form	Einzel- ausführung Loose-Piece	Anschlag- werkzeug Applicator	
0,5-1,0	-	X	CuFe, Kontaktkörper vorvergoldet über Ni, Kontaktzone vorvergoldet min. 0,6 µm CuFe, contact body pre-gold plated over nickel, contact area pre-gold plated min. 0.6 µm	2-962915-3	2-963748-3	2-878559-2	734438-1
0,5-1,0	-	X	CuFe, versilbert/CuFe, silver plated	2-962915-2	2-963748-2	2-878559-2	734438-1
0,5-1,0	-	X	CuFe, vorverzinkt/CuFe, pre-tin plated	2-962915-1	2-963748-1	2-878559-2	734438-1
0,5-1,0	-	X	CuSn, Kontaktkörper vorvergoldet über Ni, Kontaktzone vorvergoldet min. 0,6 µm CuSn, contact body pre-gold plated over nickel, contact area pre-gold plated min. 0.6 µm	1-962915-3	1-963748-3	2-878559-2	734438-1
0,5-1,0	-	X	CuSn, versilbert/CuSn, silver plated	1-962915-2	1-963748-2	2-878559-2	734438-1
0,5-1,0	-	X	CuSn, vorverzinkt/CuSn, pre-tin plated	1-962915-1	1-963748-1	2-878559-2	734438-1

**Einzelichtung:** Best.-Nr. **828904** (0,5-1,0 mm<sup>2</sup>)  
Best.-Nr. **828905** (1,5-2,5 mm<sup>2</sup>)

**Blindstopfen:** Best.-Nr. **828922**

**Single Seal:** Part No. **828904** (0.5-1.0 mm<sup>2</sup>)  
Part No. **828905** (1.5-2.5 mm<sup>2</sup>)

**Cavity Plug:** Part No. **828922**