

Vernier Caliper

SERIES 531 — with Thumb Clamp

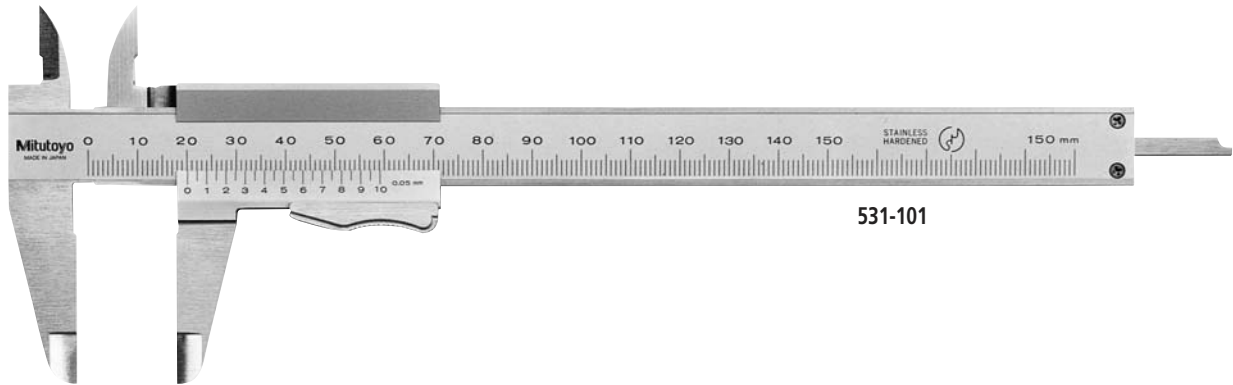

531-101

CALIPERS

FEATURES

- The slider moves only when the spring loaded thumb clamp is depressed.
- Can measure OD, ID, depth, and steps.

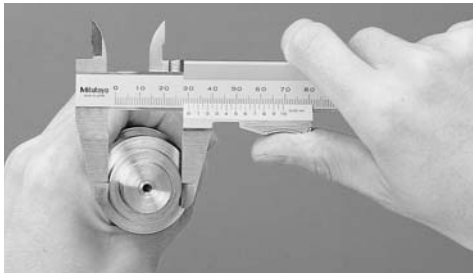

Dimensions

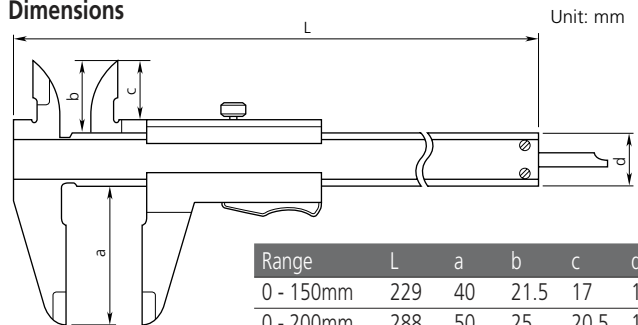

Unit: mm

| Range | L | a | b | c | d |
|-----------|-----|----|------|------|----|
| 0 - 150mm | 229 | 40 | 21.5 | 17 | 16 |
| 0 - 200mm | 288 | 50 | 25 | 20.5 | 16 |
| 0 - 300mm | 403 | 64 | 27.5 | 22 | 20 |

SPECIFICATIONS

Metric

| Range lower scale | Range upper scale | Order No. | Vernier reading (lower scale) | Vernier reading (upper scale) | Accuracy | Remarks |
|-------------------|-------------------|-----------|-------------------------------|-------------------------------|----------|----------------|
| 0 - 150mm | — | 531-101 | 0.05mm | — | ±0.05mm | With depth bar |
| | | 531-140 | 0.02mm | — | ±0.03mm | With depth bar |
| 0 - 200mm | — | 531-102 | 0.05mm | — | ±0.05mm | With depth bar |
| | | 531-141 | 0.02mm | — | ±0.03mm | With depth bar |
| 0 - 300mm | — | 531-103 | 0.05mm | — | ±0.08mm | With depth bar |
| | | 531-142 | 0.02mm | — | ±0.04mm | With depth bar |

Inch

| Range lower scale | Range upper scale | Order No. | Vernier reading (lower scale) | Vernier reading (upper scale) | Accuracy | Remarks |
|-------------------|-------------------|-----------|-------------------------------|-------------------------------|----------|----------------|
| 0 - 6" | 0 - 6" | 531-113 | .001" | 1/128" | ±.0015" | With depth bar |
| 0 - 8" | 0 - 8" | 531-114 | .001" | 1/128" | ±.0015" | With depth bar |

Metric/Inch

| Range lower scale | Range upper scale | Order No. | Vernier reading (lower scale) | Vernier reading (upper scale) | Accuracy | Remarks |
|-------------------|-------------------|-----------|-------------------------------|-------------------------------|----------|----------------|
| 0 - 150mm | 0 - 6" | 531-107 | 0.05mm | 1/128" | ±0.05mm | With depth bar |
| | | 531-122* | 0.05mm | 1/128" | ±0.05mm | With depth bar |
| | | 531-128 | 0.02mm | .001" | ±0.03mm | With depth bar |
| 0 - 200mm | 0 - 8" | 531-108 | 0.05mm | 1/128" | ±0.05mm | With depth bar |
| | | 531-129 | 0.02mm | .001" | ±0.03mm | With depth bar |
| 0 - 300mm | 0 - 12" | 531-109 | 0.05mm | 1/128" | ±0.08mm | With depth bar |
| | | 531-112 | 0.02mm | .001" | ±0.04mm | With depth bar |

*mm/inch conversion table is labeled on the underside of slider.