

# Agilent HSMF-C114 Surface Mount Tricolor ChipLEDs Data Sheet

## Description

The HSMF-C114 tricolor chip-type LED is designed in an ultra small package for miniaturization. It is the first of its kind to achieve such small packaging and be the thinnest package in the industry for tricolor package. With the freedom to have any combination of colors from mixing of the 3 primary colors, this will yield a wide variety of colors to suit every application and product theme.

The small size, narrow footprint, and low profile make this LED excellent for back-lighting, status indication, and front panel illumination applications.

In order to facilitate pick and place operation, this ChipLED is shipped in tape and reel, with 4000 units per reel. The package is compatible with reflow soldering and binned by both color and intensity.

## Features

- Common anode
- Small 1.6 x 1.5 x 0.35 mm package
- Diffused optics
- Red/Green/Blue color combination
- Available in 8 mm tape on 7" diameter reels
- High brightness using AlInGaP and InGaN die technology
- Compatible with reflow soldering

## Applications

- Backlighting
- Status indicator
- Front panel indicator
- Office automation, home appliances, industrial equipment

**CAUTION:** HSMF-C114 LEDs are Class 1 ESD sensitive. Please observe appropriate precautions during handling and processing. Refer to Agilent Technologies Application Note AN-1142 for additional details.



## Package Dimensions

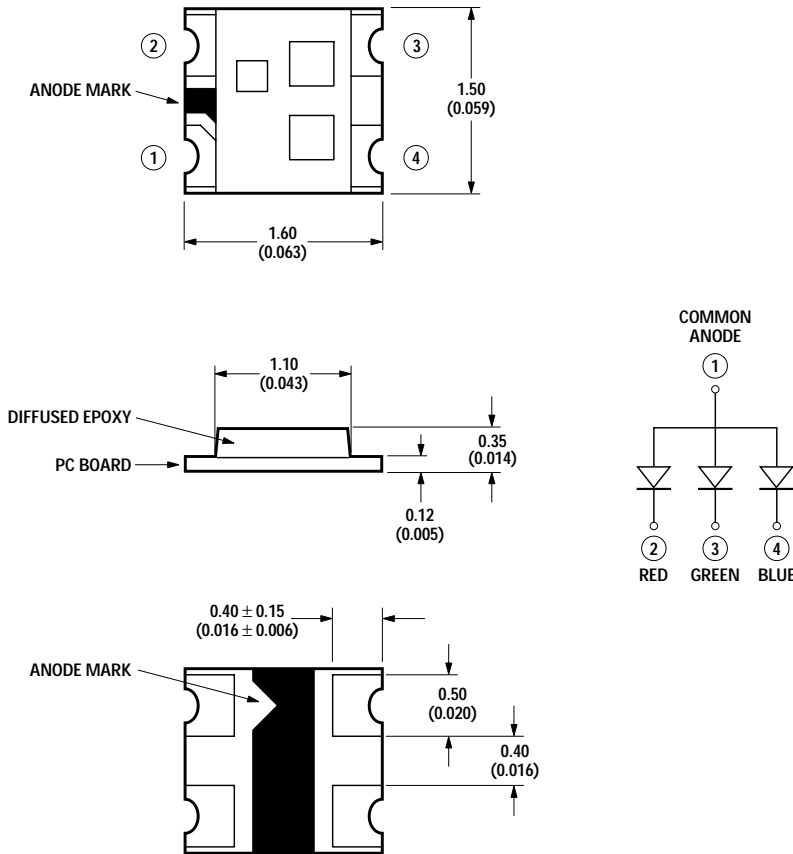

- NOTES:
1. ALL DIMENSIONS IN MILLIMETERS (INCHES).
  2. TOLERANCE IS  $\pm 0.1$  mm ( $\pm 0.004$  IN.) UNLESS OTHERWISE SPECIFIED.

## Absolute Maximum Ratings at $T_A = 25^\circ\text{C}$

Parameter	AllInGaP Red	InGaN Green	InGaN Blue	Units
DC Forward Current <sup>[1,3]</sup>	20	20	20	mA
Power Dissipation <sup>[1]</sup>	48	78	78	mW
DC Forward Current <sup>[2]</sup>	15	15	15	mA
Power Dissipation <sup>[2]</sup>	36	59	59	mW
Reverse Voltage ( $I_R = 100 \mu\text{A}$ )	5	5	5	V
LED Junction Temperature	95	95	95	$^\circ\text{C}$
Operating Temperature Range	-30 to 85			$^\circ\text{C}$
Storage Temperature Range	-40 to 85			$^\circ\text{C}$
Soldering Temperature	See reflow soldering profile (Figures 6 & 7)			

### Notes:

1. Applies when single LED is lit up.
2. Applies when all 3 LEDs are lit up simultaneously.
3. Derate linearly as shown in Figure 4.
4. Drive currents above 5 mA are recommended for best long term performance.

**Electrical Characteristics at  $T_A = 25^\circ\text{C}$**

Part Number	Forward Voltage $V_F$ (Volts) <sup>[1]</sup> @ $I_F = 20\text{ mA}$		Reverse Breakdown $V_R$ (Volts) @ $I_R = 100\ \mu\text{A}$ Min.	Capacitance $C$ (pF), @ $V_F = 0$ , $f = 1\text{ MHz}$ Typ.
	Typ.	Max.		
AllnGaP Red	1.9	2.4	5	10
InGaN Green	3.4	3.9	5	65
InGaN Blue	3.4	3.9	5	65

**Note:**

1.  $V_F$  tolerance:  $\pm 0.1\text{ V}$ .

**Optical Characteristics at  $T_A = 25^\circ\text{C}$**

Part Number	Luminous Intensity $I_V$ <sup>[1]</sup> (mcd) @ 20 mA		Peak Wavelength $\lambda_{\text{peak}}$ (nm) Typical	Color, Dominant Wavelength $\lambda_d$ <sup>[2]</sup> (nm) Typical	Viewing Angle $2\theta_{1/2}$ <sup>[3]</sup> (Degrees) Typical	Luminous Efficacy $\eta_V$ (lm/W) Typical
	Min.	Typ.				
AllnGaP Red	28.5	85.0	637	626	140	155
InGaN Green	45.0	180.0	523	525	145	477
InGaN Blue	28.5	70.0	468	470	145	75

**Notes:**

1. The luminous intensity  $I_V$  is measured at the peak of the spatial radiation pattern which may not be aligned with the mechanical axis of the LED package.
2. The dominant wavelength,  $\lambda_d$ , is derived from the CIE Chromaticity Diagram and represents the perceived color of the device.
3.  $\theta_{1/2}$  is the off-axis angle where the luminous intensity is 1/2 the peak intensity.

**CAUTION:**

1. The above optical performance specifications are valid in the case when single LED is lit up.
2. The above product specifications DO NOT

provide any guarantee on color mixing, color consistency over time, or uniformity in luminous intensity when more than 1 LED is lit.

3. Please refer to Agilent Technologies' *Application Brief AB D-007* for additional details/explanation on driving the part in parallel circuit.

**Light Intensity (I<sub>v</sub>) Bin Limits<sup>[1]</sup>**

Bin ID	Intensity (mcd)	
	Minimum	Maximum
A	0.11	0.18
B	0.18	0.29
C	0.29	0.45
D	0.45	0.72
E	0.72	1.10
F	1.10	1.80
G	1.80	2.80
H	2.80	4.50
J	4.50	7.20
K	7.20	11.20
L	11.20	18.00
M	18.00	28.50
N	28.50	45.00
P	45.00	71.50
Q	71.50	112.50
R	112.50	180.00
S	180.00	285.00
T	285.00	450.00

Tolerance: ± 15%

**Note:**

1. Bin categories are established for classification of products. Products may not be available in all categories. Please contact your Agilent representative for information on current available bins.

**AllInGaP Red Color Bin Limits<sup>[1]</sup>**

Bin ID	Dom. Wavelength (nm)	
	Minimum	Maximum
—	615.0	630.0

Tolerance: ± 1 nm

**InGaN Green Color Bin Limits<sup>[1]</sup>**

Bin ID	Dom. Wavelength (nm)	
	Minimum	Maximum
A	515.0	520.0
B	520.0	525.0
C	525.0	530.0
D	530.0	535.0

Tolerance: ± 1 nm

**InGaN Blue Color Bin Limits<sup>[1]</sup>**

Bin ID	Dom. Wavelength (nm)	
	Minimum	Maximum
A	460.0	465.0
B	465.0	470.0
C	470.0	475.0
D	475.0	480.0

Tolerance: ± 1 nm

**Note:**

1. Bin categories are established for classification of products. Products may not be available in all categories. Please contact your Agilent representative for information on current available bins.

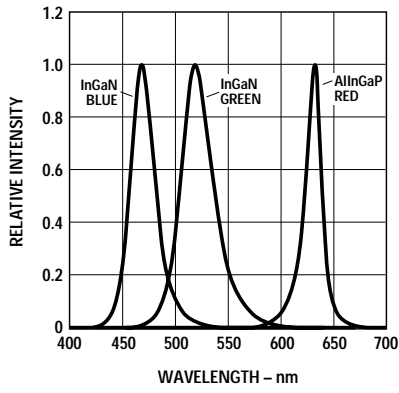

Figure 1. Relative intensity vs. wavelength.

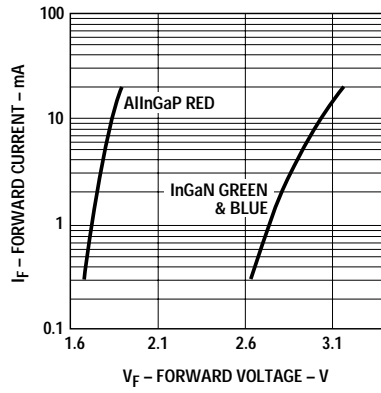

Figure 2. Forward current vs. forward voltage. Luminous intensity vs. forward current.

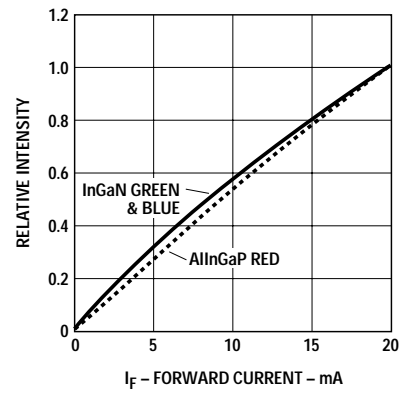

Figure 3. Luminous intensity vs. forward current.

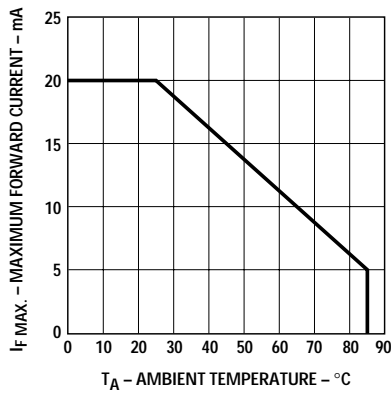

Figure 4. Maximum forward current vs. ambient temperature.

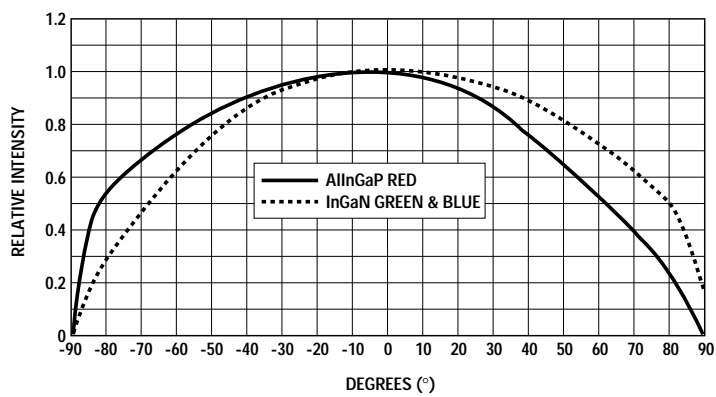

Figure 5. Relative intensity vs. angle.

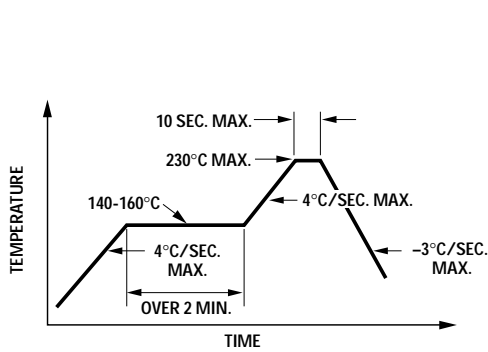
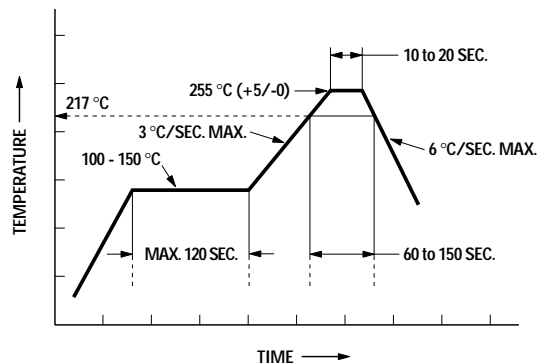

Figure 6. Recommended reflow soldering profile.



\* THE TIME FROM 25 °C TO PEAK TEMPERATURE = 6 MINUTES MAX.

Figure 7. Recommended Pb-free reflow soldering profile.

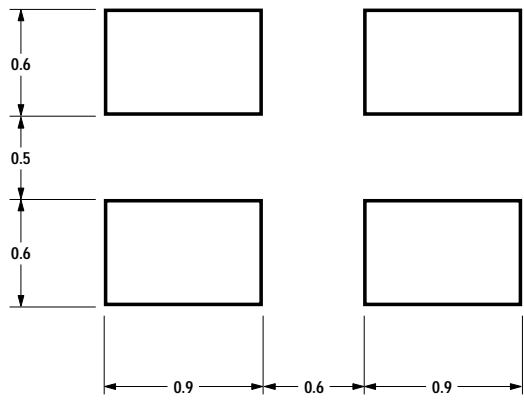

Figure 8. Recommended soldering land pattern.

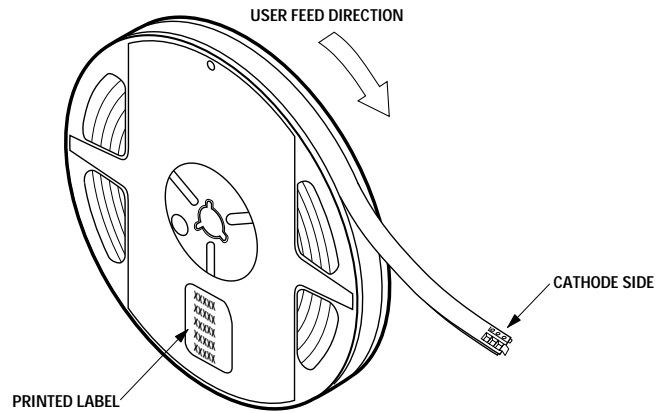
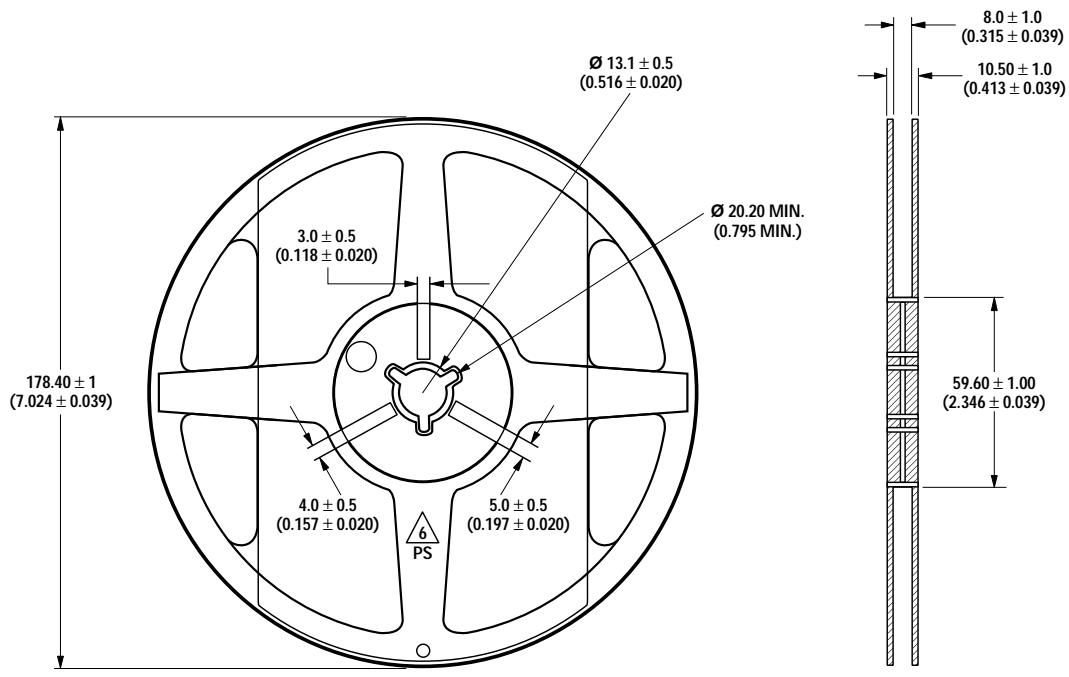
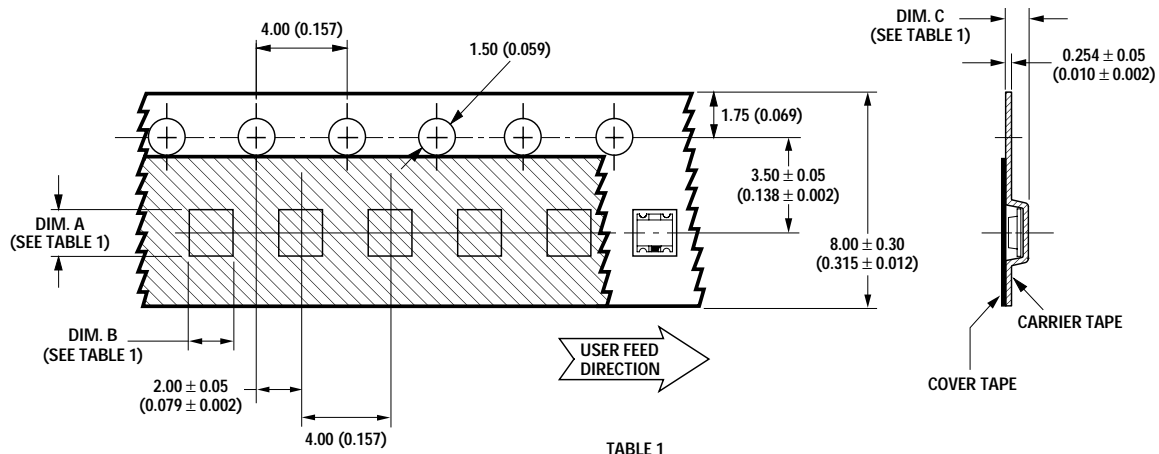

Figure 9. Reeling orientation.



NOTE:  
1. ALL DIMENSIONS IN MILLIMETERS (INCHES).

Figure 10. Reel dimensions.



**TABLE 1**  
**DIMENSIONS IN MILLIMETERS (INCHES)**

PART NUMBER	DIM. A ± 0.10 (± 0.004)	DIM. B ± 0.10 (± 0.004)	DIM. C ± 0.10 (± 0.004)
HSMF-C114	1.75 (0.069)	1.65 (0.065)	0.55 (0.022)

Figure 11. Tape dimensions.

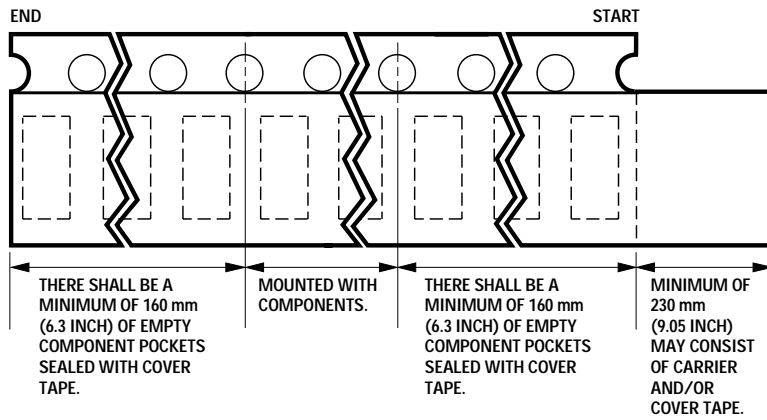

Figure 12. Tape leader and trailer dimensions.

### **Convective IR Reflow Soldering**

For more information on reflow soldering, refer to Application Note 1060, *Surface Mounting SMT LED Indicator Components*.

#### **Storage Condition:**

5 to 30°C @ 60% RH max.

Baking is required before mounting if:

1. Humidity Indicator Card is > 10% when read at 23 ± 5°C.
2. Device exposed to factory conditions < 30°C/60% RH more than 672 hours.

Recommended baking condition:

60 ± 5°C for 20 hours.

### **[www.agilent.com/semiconductors](http://www.agilent.com/semiconductors)**

For product information and a complete list of distributors, please go to our web site.

For technical assistance call:

Americas/Canada: +1 (800) 235-0312 or (916) 788-6763

Europe: +49 (0) 6441 92460

China: 10800 650 0017

Hong Kong: (+65) 6756 2394

India, Australia, New Zealand: (+65) 6755 1939

Japan: (+81 3) 3335-8152(Domestic/International), or 0120-61-1280(Domestic Only)

Korea: (+65) 6755 1989

Singapore, Malaysia, Vietnam, Thailand, Philippines, Indonesia: (+65) 6755 2044

Taiwan: (+65) 6755 1843

Data subject to change.

Copyright © 2005 Agilent Technologies, Inc.

June 17, 2005

5989-3351EN



**Agilent Technologies**