

Type: **DILEM-10(380V50HZ,440V60HZ)**  
 Article No.: **051787**



### Ordering information

Actuating voltage			380V 50Hz, 440V 60Hz
Description			3-pole, with auxiliary contacts
Connection technique			Screw terminals
380 V 400 V	$I_e$	A	8.8
Max. rating for three-phase motors, 50 – 60 Hz AC-3 220 V 230 V	$P$	kW	2.2
Max. rating for three-phase motors, 50 – 60 Hz AC-3 380 V 400 V	$P$	kW	4
Max. rating for three-phase motors, 50 – 60 Hz AC-3 660 V 690 V	$P$	kW	4
Max. rating for three-phase motors, 50 – 60 Hz AC-4 220 V 230 V	$P$	kW	1.5
Max. rating for three-phase motors, 50 – 60 Hz AC-4 380 V 400 V	$P$	kW	3
Max. rating for three-phase motors, 50 – 60 Hz AC-4 660 V 690 V	$P$	kW	3
Conventional thermal current $I_{th} = I_e$ AC-1 Open	$I_{th} = I_e$	A	20
Conventional thermal current $I_{th} = I_e$ AC-1 Enclosed	$I_{th} = I_e$	A	16
Contacts M = Make			1 M
Can be combined with auxiliary contact			...DILEM ...DILE

### Contact sequence

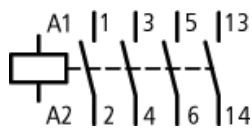

### Notes concerning the product group

With screw terminals:

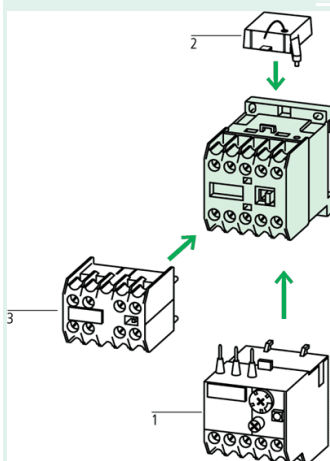

*Accessories*

1 Overload relay → 014263

2 Suppressor → 044264

3 Auxiliary contact modules → 010064

Enclosure totally insulated

Other actuating voltages → 068294

Accessories → 044264

With springloaded terminal:

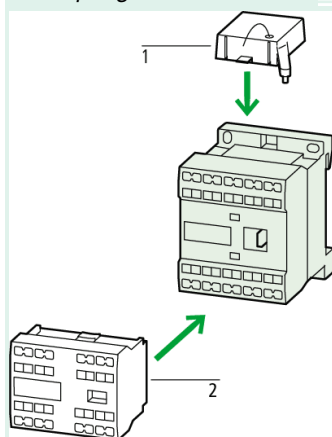

*Accessories*

1 Suppressor → 044264

2 Auxiliary contact modules → 010064

Enclosure totally insulated

Other actuating voltages → 230031

Accessories → 044264

Mini contactor relays with interlocked opposing contacts.

**General**

Standards

IEC/EN 60947, VDE 0660, CSA, UL

Lifespan, mechanical; Coil 50/60 Hz	at 50 Hz		7
Lifespan, mechanical	Operations	$\times 10^6$	> 10
Maximum operating frequency			
Mechanical		Ops./h	9000
Climatic proofing			Damp heat, constant, to IEC 60068–2–78 Damp heat cyclic to IEC 60068–2–30
Ambient temperature			
Open		°C	–25/50
Enclosed		°C	–25/40
Mechanical shock resistance (IEC/EN 60068–2–27)			
Half-sinusoidal shock, 10 ms			
Basic unit without auxiliary contact module			
Main contacts, make contacts		g	10
Main contacts Make/break contacts		g	10/8
Basic unit with auxiliary contact module			
Main contacts make contact		g	10
Auxiliary contacts Make/break contacts		g	20/20
Protection type			IP20
Protection against direct contact when actuated from front (IEC 536)			Finger and back-of-hand proof
Terminal capacity of auxiliary and main contacts			
Solid		mm <sup>2</sup>	1 × (0.75 – 2.5) 2 × (0.75 – 2.5)
Flexible with ferrule		mm <sup>2</sup>	1 × (0.75 – 1.5) 2 × (0.75 – 1.5)
Solid or stranded		AWG	18 – 14
Terminal screw			M3.5
Pozidriv screwdriver		Size	2
Standard screwdriver		mm	0.8 × 5.5 1 × 6
max. tightening torque		Nm	1,2
Anschlussquerschnitte Federzugklemmen Hauptleiter und Hilfsleiter			
Solid		mm <sup>2</sup>	1 × (1 – 2.5) 2 × (1 – 2.5)
Flexible with ferrule		mm <sup>2</sup>	1 × (1 – 2.5) 2 × (1 – 2.5)
Standard screwdriver		mm	0.6 × 3.5
<b>Main conducting paths</b>			
Rated impulse withstand voltage	$U_{imp}$	V AC	6000
Overvoltage category/pollution degree			III/3
Rated insulation voltage			
AC	$U_i$	V AC	690
Rated operational voltage			
Rated operational voltage	$U_e$	V AC	690
Safe isolation to VDE 0106 Part 101 and Part 101/A1			
between coil and contacts		V AC	300
between the contacts		V AC	300

Making capacity (cos $\bar{O}$ to IEC/EN 60947)		A	110
Breaking capacity			
220/230 V		A	90
380/400 V		A	90
500 V		A	64
660/690 V		A	54
Component lifespan			
Short-circuit protection Maximum fuse			
Type "2" coordination	gL/gG	A	10
Type "1" coordination	gL/gG	A	20
<b>AC</b>			
AC-1 duty			
conv. therm. current 3-pole 50 – 60 Hz			
open			
at 40 °C	$I_{th}$	A	22
at 50 °C	$I_{th}$	A	20
at 55 °C	$I_{th}$	A	19
Enclosed	$I_{th}$	A	16
Conventional free air thermal current, 1-pole			
open			
1-pole open	$I_{th}$	A	50
Enclosed			
conv. therm. current three/four main contacts in parallel, enclosed	$I_{th}$	A	40
AC-3 duty			
Rated operational current AC-3 open, 50 – 60 Hz, 3-pole			
220/230 V	$I_e$	A	9
240 V	$I_e$	A	9
380/400 V	$I_e$	A	8,8
415 V	$I_e$	A	9
440V	$I_e$	A	9
500 V	$I_e$	A	6,4
660/690 V	$I_e$	A	4,8
Rating, AC-3 motor load switch			
220/230 V	$P$	kW	2,2
240V	$P$	kW	2,5
380/400 V	$P$	kW	4
415 V	$P$	kW	4,3
440 V	$P$	kW	4
500 V	$P$	kW	4
660/690 V	$P$	kW	4
AC-4 duty			
Rated operational current AC-4 open, 50 – 60 Hz, 3-pole			

220/230 V	$I_e$	A	6,6
240 V	$I_e$	A	6,6
380/400 V	$I_e$	A	6,6
415 V	$I_e$	A	6,6
440 V	$I_e$	A	6,6
500 V	$I_e$	A	5
660/690 V	$I_e$	A	3,4
AC-4			
220/230 V	$P$	kW	1,5
240 V	$P$	kW	1,8
380/400 V	$P$	kW	3
415 V	$P$	kW	3,1
440 V	$P$	kW	3
500 V	$P$	kW	3
660/690 V	$P$	kW	3

## DC

Operations			
DC-1			
12 V	$I_e$	A	20
24 V	$I_e$	A	20
60 V	$I_e$	A	20
110 V	$I_e$	A	20
220 V	$I_e$	A	20
DC-3			
12 V	$I_e$	A	8
24 V	$I_e$	A	8
60 V	$I_e$	A	4
110 V	$I_e$	A	3
DC-5			
12 V	$I_e$	A	2,5
24 V	$I_e$	A	2,5
60 V	$I_e$	A	2,5
110 V	$I_e$	A	1,5
220 V	$I_e$	A	0,3
Current heat losses (3- or 4-pole)			
to $I_{th}$		W	2
at $I_e$ to AC-3/400 V		W	0,5

## Magnet systems

Voltage tolerance			
Single-voltage coil 50 Hz and dual-voltage coil 50 Hz, 60 Hz	Pick-up	$\times U_s$	0,8 – 1,1
Dual-frequency coil 50/60 Hz	Pick-up	$\times U_s$	0,85 – 1,1
Power consumption			
AC operation			
Single-voltage coil 50 Hz and dual-voltage coil 50 Hz, 60 Hz	Pick-up	VA	25

Single-voltage coil 50 Hz and dual-voltage coil 50 Hz, 60 Hz	Pick-up	W	22
Single-voltage coil 50 Hz and dual-voltage coil 50 Hz, 60 Hz	Sealing	VA	4,6
Single-voltage coil 50 Hz and dual-voltage coil 50 Hz, 60 Hz	Sealing	W	1,3
Dual-frequency coil 50/60 Hz at 50 Hz	Pick-up	VA	30
Dual-frequency coil 50/60 Hz at 50 Hz	Pick-up	W	26
Dual-frequency coil 50/60 Hz at 50 Hz	Sealing	VA	5,4
Dual-frequency coil 50/60 Hz at 50 Hz	Sealing	W	1,6
Dual-frequency coil 50/60 Hz at 60 Hz	Pick-up	VA	29
Dual-frequency coil 50/60 Hz at 60 Hz	Pick-up	W	24
Dual-frequency coil 50/60 Hz at 60 Hz	Sealing	VA	3,9
Dual-frequency coil 50/60 Hz at 60 Hz	Sealing	W	1,1
Duty factor		% DF	100
Switching times at 100 % $U_c$			
Make contact			
Closing delay			
Closing delay min.		ms	14
Closing delay max.		ms	21
Opening delay			
Opening delay min.		ms	8
Opening delay max.		ms	18
Closing delay with top mounting auxiliary contact		ms	max. 45
Reversing contactors			
Changeover time at 110 % $U_c$			
Changeover time min.		ms	16
Changeover time max.		ms	21
Arcing time at 690 V AC		ms	max. 12
<b>Auxiliary contacts</b>			
Interlocked opposing contacts to ZH 1/457, including auxiliary contact module			Yes
Rated impulse withstand voltage	$U_{imp}$	V AC	6000
Overvoltage category/pollution degree			III/3
Rated insulation voltage	$U_i$	V AC	690
Rated operational voltage			
Rated operational voltage	$U_e$	V AC	600
Safe isolation to VDE 0106 Part 101 and Part 101/A1			
between coil and auxiliary contacts		V AC	300
between the auxiliary contacts		V AC	300
Rated operational current			
AC-15			
220/240 V	$I_e$	A	6
380/415 V	$I_e$	A	3
500 V	$I_e$	A	1,5
DV-13			

Contacts in series:			
1	24 V	A	2,5
2	60 V	A	2,5
3	100 V	A	1,5
3	220 V	A	0,5
Conventional thermal current	$I_{th}$	A	10
Control circuit reliability (at $U_e = 24$ V DC, $U_{min} = 17$ V, $I_{min} = 5.4$ mA)	Failure rate	»	-8, < one failure at 100 million operations
Component lifespan at $U_e = 240$ V			
AC-15	Operations	$\times 10^6$	0,2
DC-13			
L/R = 50 ms: 2 contacts in series at $I_e = 0.5$ A	Operations	$\times 10^6$	0,15
Short-circuit rating without welding			
Maximum overcurrent protective device			PKZM0-4
Short-circuit protection Maximum fuse			
500 V		A gG/gL	6
500 V		A fast	10
Current heat loss at $I_{th}$			
Per contact		W	0,2

### Notes

At maximum permissible ambient temperature.  
Smoothed DC or three-phase bridge rectifier  
Making and breaking conditions to DC-13, time L/R constant as stated

### Dimensions

### Mounting position

As required except vertical with terminals A1/A2 at the bottom



### Dimensions

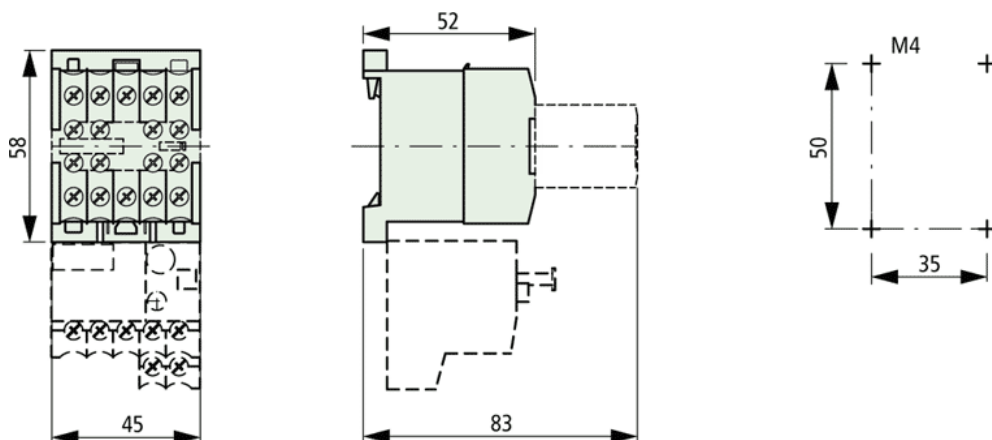

Moeller GmbH, Hein-Moeller-Str. 7-11, D-53115 Bonn  
E-Mail: [catalog@moeller.net](mailto:catalog@moeller.net), Internet: [www.moeller.net](http://www.moeller.net), <http://catalog.moeller.net>  
Copyright 2005 by Moeller GmbH. Subject to modifications. HPL-C2005GB-INT V3.0