

## Aluminium Bügelgriffe

## Aluminium Bow-Type Handles

### Technische Daten

Werkstoff Al Mg Si 0,5  
Belastbarkeit 750N

### Technical Data

Material Al Mg Si 0,5  
Carrying capacity 750N

Bügelgriff im Besonderen für 19"-Einschübe und Geräte. Es sind speziell Zug- und Schubtätigkeiten als Anforderung berücksichtigt. Bei Griffen für 19"-Frontplatten bedeutet: HE = Höheneinheit

Bow-type handle in particular for 19" racks and devices. It meets the particular requirements of pulling and pushing actions. For handles to be used with 19" front panels, „HE" means „height units"

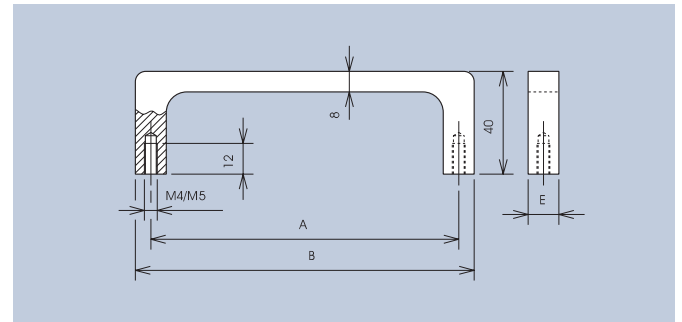

#### schmale Ausführung M4 x 12 · small version M4 x 12

HE	A	B	E	Art.-Nr. naturton elox. natural anod.	Art.-Nr. schwarz elox. black anod.
1	32	44	7,8	3299.1131	3299.1133
2	75,5	87,5	7,8	<b>3299.1231</b>	<b>3299.1233</b>
3	120	132	7,8	<b>3299.1301</b>	<b>3299.1303</b>

#### breite Ausführung M5 x 12 · wide version M5 x 12

HE	A	B	E	Art.-Nr. naturton elox. natural anod.	Art.-Nr. schwarz elox. black anod.
1	32	44	12	3299.2131	3299.2133
2	75,5	87,5	12	3299.2231	3299.2233
3	120	132	12	3299.2301	3299.2303

Einschließlich Zylinderschrauben-M4 x 12 bzw. M5 x 12 und Scheiben.  
Including cheese head screws-M4 x 12 respectively M5 x 12 and washers.

### Technische Daten

Werkstoff GD-Al Si 12 (Cu)  
Belastbarkeit 750N

### Technical Data

Material GD-Al Si 12 (Cu)  
Carrying capacity 750N

Dieser Bügelgriff verwirklicht dank des abgerundeten Querschnitts ergonomische Anforderungen.

Due to the rounded cross-section, this bow-type handle implements ergonomic requirements.

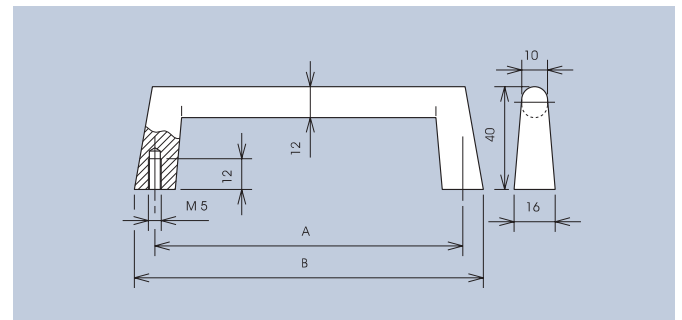

A	B	Art.-Nr. gleitgeschliffen vibration grounded	Art.-Nr. pulverbesch. schwarz powdercoated black
120	136	287.3	3287.1203
180	196	287.4	3287.1803

Einschließlich Zylinderschrauben-M5 x 12 und Scheiben.  
Including cheese head screws-M5 x 12 and washers.