



FUTTERS
(LONDON)
LTD.

PRODUCT
SPECIFICATION

INSTRUMENT CASE

Sheet No. **PS 0712**

Date : 28.04.94

Issue No. 1

Sheet 1 of 1

Signature

Deltron Part No. **512-0900**

Dimensions

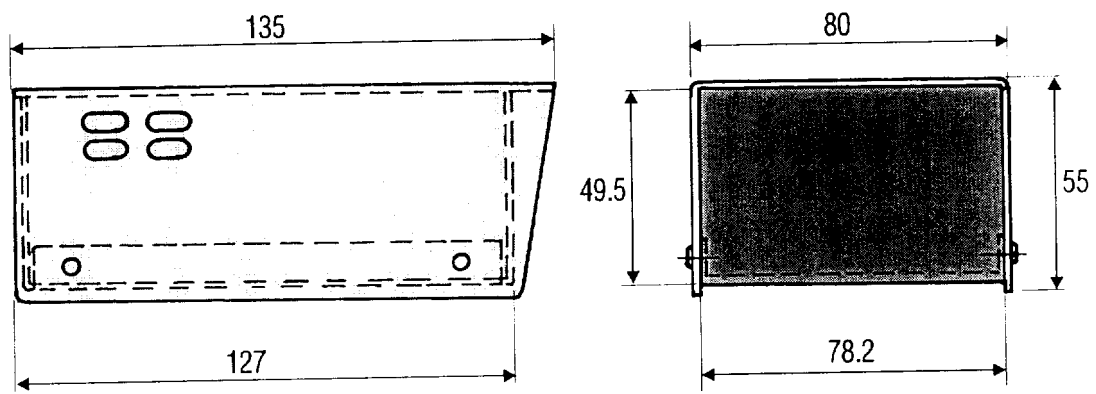

DIMENSIONS IN MILLIMETRES

Description

Instrument cases have cowl-type cover to reduce the glare from overhead lighting, and a two tone grey paint finish. They are attractively styled and can provide housing for many purposes in the electronic instrumentation field, such as power supplies, controllers, amplifiers and meters, etc.

They are of a two part all steel construction and fit together with self-tapping screws. Their rugged construction make the cases suitable for all free standing uses. Covers have air vents as illustrated. Materials : Cover & Base - galvanised mild steel. Material thickness of Cover is 0.9mm & Base is 1.2mm.