

Long collets for unscreened cable «U» for connector styles S, SV, SOV, K, DK

Cable Dia. Range	Collet Dia. for ordering	P/N for Packaged Collet (only for separate ordering) ①	Collet «A»	Collet «B»
2.2 - 3.2	3.2	103.252	103.1414	103.1414
3.2 - 4.2	4.2	103.254	103.1413	103.1413
4.2 - 4.7	4.7	103.253	103.1412	103.1412
4.7 - 5.2	5.2	103.238	103.1411	103.1411
5.2 - 5.7	5.7	103.251	103.1410	103.1410
5.7 - 6.2	6.2	103.250	103.1409	103.1409
6.2 - 6.7	6.7	103.259	103.1408	103.1408

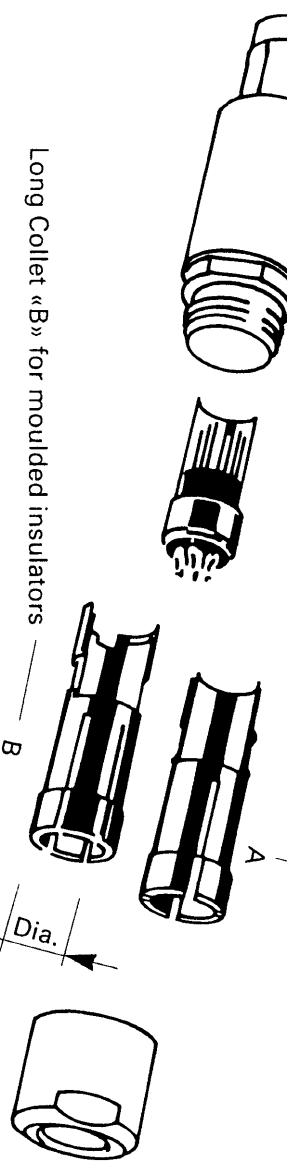

Sleeve «B» for connectors with moulded Insulators, P/N 103.1407

Collets and internal parts for SE, SVE, SOVE, KE, DKE for screened and unscreened cable

P/N required for separate ordering only

Cable Dia. Range	Collet Dia. for ordering	Collet ①	Seal ②	Washer ③	Ring ④	Set ①-⑤ packaged in tube with Sleeve «A»	Set ①-⑤ packaged in tube with Sleeve «B»
1.7 - 2.2	2.2	E32 103.2/2.2	103.1536	103.1535	103.1256	E31 103.2/2.2 + A	E31 103.2/2.2 + B
2.2 - 2.7	2.7	E32 103.2/2.7	103.1536	103.1534	103.1256	E31 103.2/2.7 + A	E31 103.2/2.7 + B
2.7 - 3.2	3.2	E32 103.2/3.2	103.1270	103.1263	103.1256	E31 103.2/3.2 + A	E31 103.2/3.2 + B
3.2 - 3.7	3.7	E32 103.2/3.7	103.1269	103.1262	103.1255	E31 103.2/3.7 + A	E31 103.2/3.7 + B
3.7 - 4.2	4.2	E32 103.2/4.2	103.1268	103.1261	103.1254	E31 103.2/4.2 + A	E31 103.2/4.2 + B
4.2 - 4.7	4.7	E32 103.2/4.7	103.1267	103.1260	103.1253	E31 103.2/4.7 + A	E31 103.2/4.7 + B
4.7 - 5.2	5.2	E32 103.2/5.2	103.1266	103.1259	103.1252	E31 103.2/5.2 + A	E31 103.2/5.2 + B
5.2 - 5.7	5.7	E32 103.2/5.7	103.1265	103.1258	103.1251	E31 103.2/5.7 + A	E31 103.2/5.7 + B
5.7 - 6.2	6.2	E32 103.2/6.2	103.1264	103.1257	103.1250	E31 103.2/6.2 + A	E31 103.2/6.2 + B

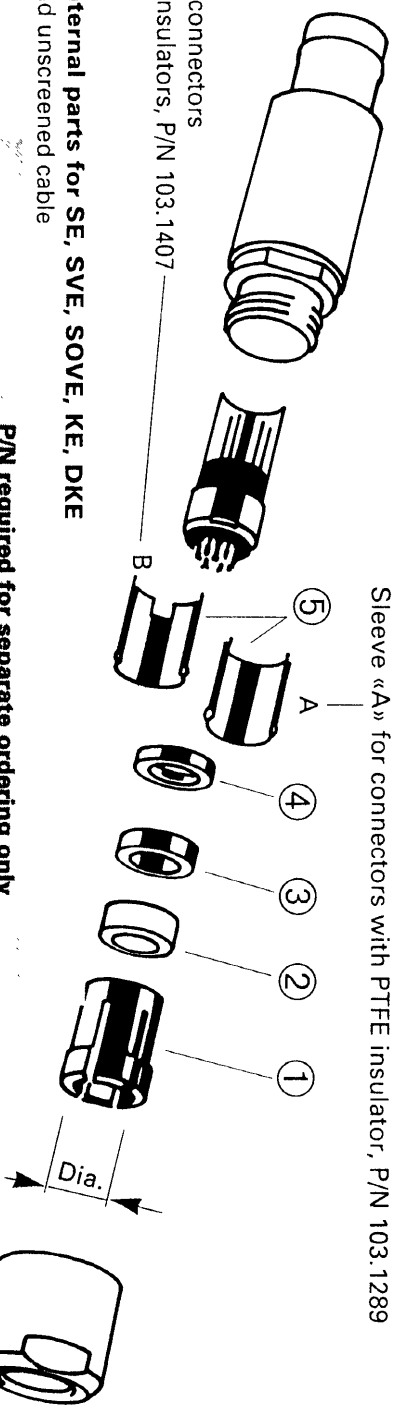

Sleeve «A» for connectors with PTFE insulator, P/N 103.1289

① We have begun shipping the cable clamp assemblies in a disposable plastic tube. In this case, a disposable Internal Retainer keeps the contact block in place. For details see page L6 and «General Cable Assembly Instructions» on page N2.

2

① We have begun shipping the cable clamp assemblies in a disposable plastic tube. In this case, a disposable Internal Retainer keeps the contact block in place. For details see page L6 and «General Cable Assembly Instructions» on page N2.

2

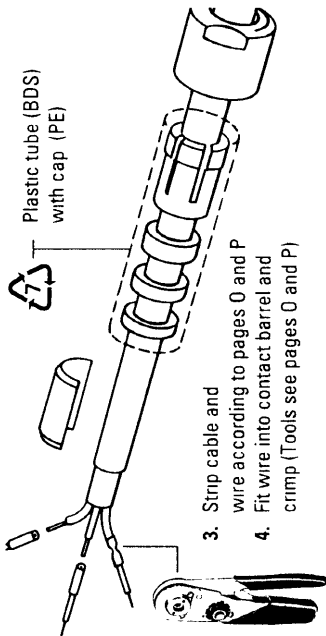

3. Strip cable and wire according to pages O and P
4. Fit wire into contact barrel and crimp (Tools see pages O and P)

### CRIMP CONTACTS

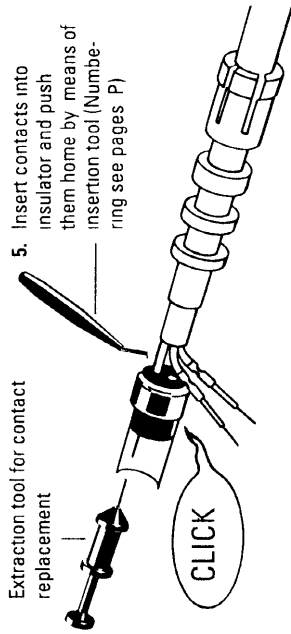

- Extraction tool for contact replacement
5. Insert contacts into insulator and push them home by means of insertion tool (Numbering see pages P)

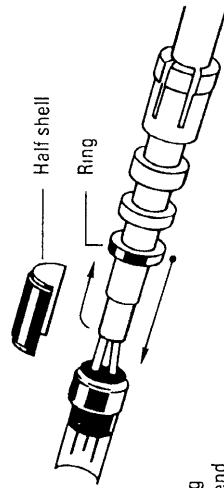

6. Slide the ring to the front end
7. Bend cable screen outwards
8. Insert half shell and retain with the ring

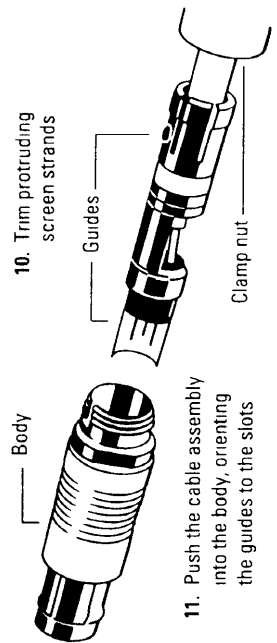

11. Push the cable assembly into the body, orienting the guides to the slots

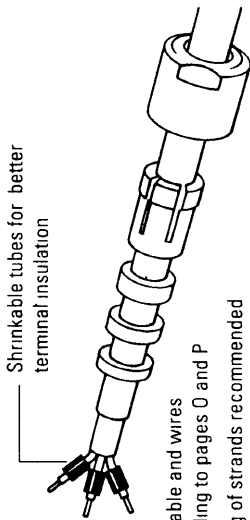

- 3'. Strip cable and wires according to pages O and P
- 4'. Tinning of strands recommended

### SOLDER CONTACTS

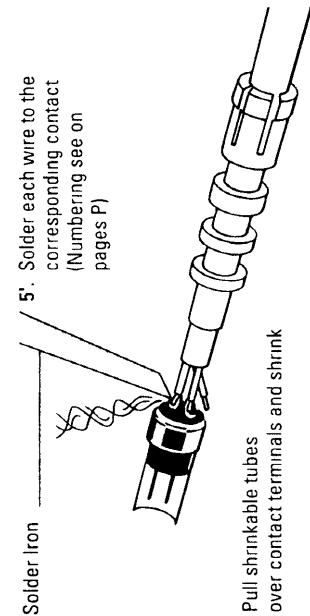

- Solder Iron
- 5'. Solder each wire to the corresponding contact (Numbering see on pages P)
- Pull shrinkable tubes over contact terminals and shrink

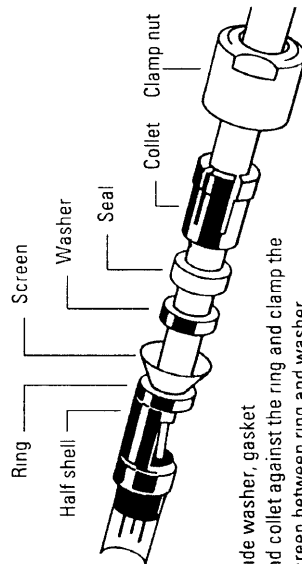

9. Slide washer, gasket and collet against the ring and clamp the screen between ring and washer

12. Screw clamp nut to the body and tighten by means of wrenches (see pages O and P)

The assembly is now finished

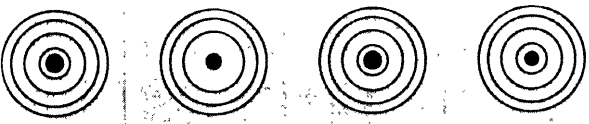

102 A002	S	9.5	12
	E	9.5	12
102 A017	S	6	8.5
102 Z017	E	5	7
102 A018	S	9.5	12
102 Z018			
102 A025	S	21	29
102 Z025			
(RG 58 cable)			

965 194

20557

S - Short collet  
E - Sealed version

All dime  
All strip  
adjusted

