

## D.C. direct drive motors Ø 42 mm and 63 mm

- For high-power drive applications
- Maximum usable power : from 14 to 67 W
- Ø 42 mm : Sintered bronze bearings lubricated for life  
Supply connection by 2 leads

### Long service life motors :

- Ø 63 mm : With 2 ball bearings  
Supply connection by 2 leads

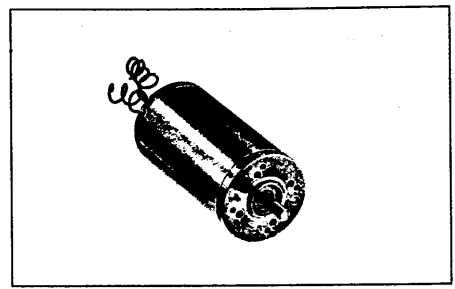

### Applications

- Gas analysers
- Pumps/vacuum devices
- Cash registers
- Printers
- Mixers for automatic drink dispensers
- Compressors
- Spindle drives for engraving machines
- Document sorters
- Automatic swimming-pool cleaners
- Filtering systems
- Water circulators for whirlpool baths
- Paper drives for photocopiers
- Opening/closing of automatic doors
- Machines for making spectacle lenses

1

### Made to order products, available on request

- integrated interference suppression
- other supply voltages
- shaft lengths at front and/or rear
- motor with 1 or 2 ball bearings (82 850)
- other front and rear fixing plates
- optical encoder 200 pulses per revolution

Type	82 800 8	82 800 8	82 850 0	82 850 0	
<b>Nominal voltage</b>	12 V	24 V	12 V	24 V	
<b>Part number</b>	82 800 801	82 800 802	82 850 001	82 850 002	
<b>Standard Characteristics</b>					
Speed	rpm	3920	4010	4150	4050
Absorbed power	W	9.96	12.24	7.32	7.44
Absorbed current	A	0.83	0.51	0.61	0.31
<b>Characteristics - nominal</b>					
Speed	rpm	2670	3070	3100	3200
Torque	mN.m	70	70	100	100
Output power	W	20	22	32.5	33.5
Absorbed power	W	37	41	51	52
Absorbed current	A	3.05	1.71	4.25	2.15
Gearbox case temperature rise	°C	38	40	63	54
Efficiency	%	54	54	63	64
<b>General characteristics</b>					
Insulation class (conforming to IEC 85)	F (155 °C)	F (155 °C)	F (155 °C)	F (155 °C)	
Degree of protection (IEC 529)	IP20	IP20	IP20	IP20	
Maximum usable power	W	22	31	42	52
Start torque	mN.m	219	298	390	490
Start current	A	9	6.16	14.8	9.6
Resistance	Ω	1.33	3.9	0.81	2.5
Resistance : inductive	mH	2.67	9.35	0.7	2.5
Torque constant	Nm/A	0.0268	0.0527	0.027	0.052
Electrical time constant	ms	2	2.4	0.85	1
Mechanical time constant	ms	20	15	16	13
Thermal time constant	min	12	12	26	21
Inertia	g.cm <sup>2</sup>	105	110	140	140
Weight	g	400	400	640	640
No of segments		8	8	8	8
Life	h	3000	3000	3000	3000
Ball bearings					
Sintered bronze bearings	yes	yes	yes	yes	
Lead length	mm	200	200	200	200

### A - Torque/Speed curves B - Torque/Current curves

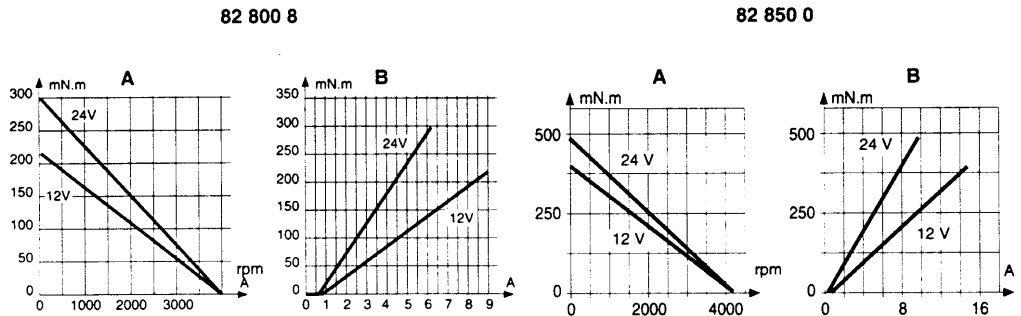

### Other information

Basic principles see page 1/4.

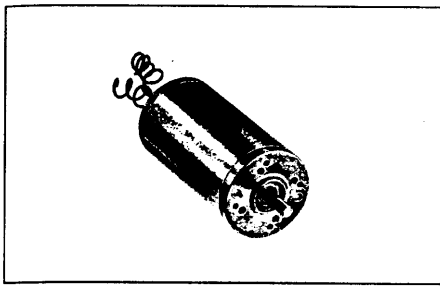

82 890 0      82 890 0

24 V      48 V

82 890 001      82 890 002

3700	3750
10.8	9.6
0.45	0.2

3200	3360
270	270
90	95
120	118
5.00	2.45
50	50
75	80

F (155 °C)	F (155 °C)
IP20	IP20
194	255
2000	2600
34.1	21.7
0.7	2.2
1.05	4.62
0.059	0.12
1.5	2.1
16	12
41	36
795	795
1580	1580
12	12
5000	5000
yes	yes
200	200

A - Torque/Speed curves  
B - Torque/Current curves

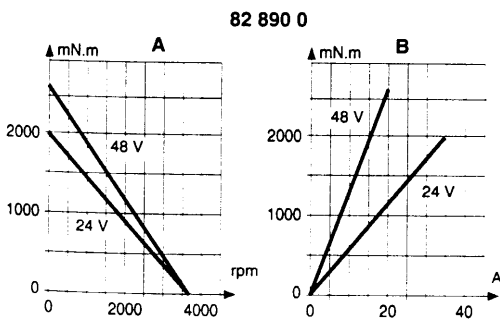

Dimensions : 82 890 0

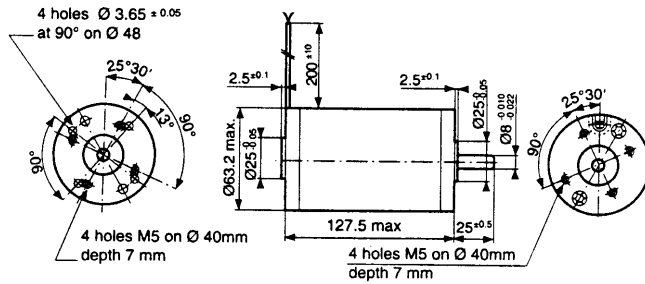

Dimensions : 82 800 8

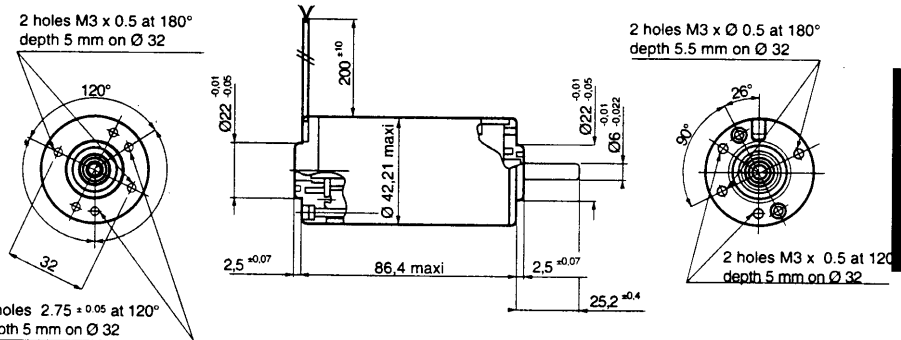

Dimensions : 82 850 0

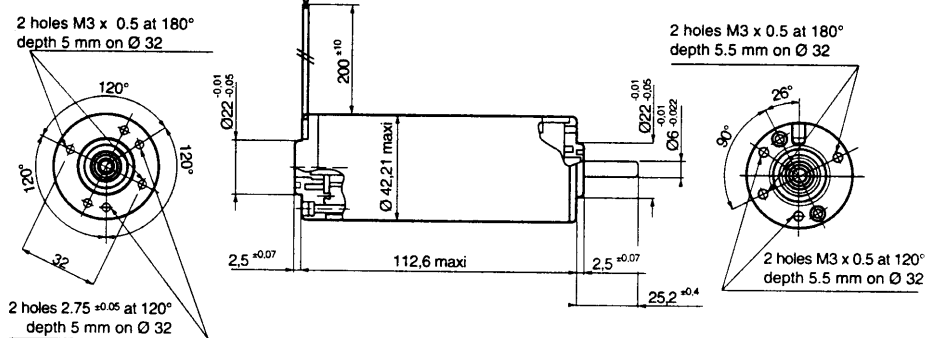

To order, specify :

Standard products

Part number

Example : D.C. direct drive motor - 82 890 001

Standard products,  
non stocked

Part number

Example : D.C. direct drive motor - 82 800 802 - 24 volts