

- ◆ **Input Voltage Range** : 1.8V ~ 5.5V
- ◆ **Output Voltage Range** : 2.5V ~ 5.2V
- ◆ **Oscillator Frequency** : 300kHz
- ◆ **Maximum Output Current** : 80mA (3.6→5V step-up)
- ◆ **PFM (pulse skip) Operation During Light Loads (XC9802)**
- ◆ **CE (chip enable) Function**
- ◆ **MSOP-8A Package**

■ **General Description**

The XC9801 series are fixed regulated voltage step-up charge pump ICs which provide stable, highly efficient, positive voltages with the only external components required being 2 capacitors. Output voltage is selectable in 0.1V steps within a 2.5V ~ 5.2V range. Since regulating is done via the control of the charge pump's output impedance, ripple is minimal. Control of XC9802 switches to PFM (pulse skip) during light loads without affecting output impedance or ripple so that the IC is protected against drops in efficiency. Connecting the SENSE pin to the GND pin allows the IC to be used as a voltage doubler.

As well as the ultra small MSOP-8A package, the small consumption current and high efficiencies of the series make the XC9801 suitable for use with all types of battery operated applications.

■ **Pin Configuration**

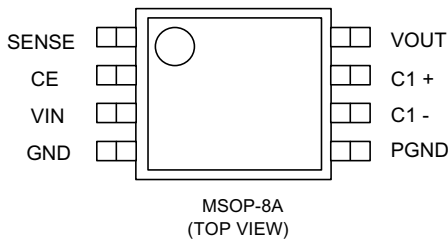

■ **Selection Guide**

SERIES	FUNCTION	
XC9801	pulse skip	×
XC9802	pulse skip	○

■ **Ordering Information**

XC9801/02 ①②③④⑤⑥

DESIGNATOR	DESCRIPTION	
①	B	True Logic Level at CE Pin : Positive
② ③	25~52	Output Voltage (2.5V ~ 5.2V) 5.0V → ②=5, ③=0
④	3	Oscillator Frequency : 300kHz
⑤	K	Package : MSOP-8A
⑥	R	Embossed tape. Standard Feed
	L	Embossed tape. Reverse Feed

■ **Applications**

- Palm top computers, PDAs
- On Board Local Power Supplies
- Various Battery Powered Devices

■ **Features**

- Input Voltage Range** : 1.8V ~ 5.5V
- Output Voltage Range** : 2.5V ~ 5.2V
- Small Input Current** : 80μA (no load:XC9802)
- Output Current** : 80mA (3.6V→ 5V step-up)
- Oscillator Frequency** : 300kHz
- Stand-By Current (CE 'L')** : 2.0μA (max)
- Can be used as a Step-Up Doubler (sense = 0V)**
- MSOP-8A Package**

■ **Pin Assignment**

PIN NUMBER	PIN NAME	FUNCTION
1	SENSE	Output Voltage Monitor
2	CE	Chip Enable
3	VIN	Input (power supply)
4	GND	Ground
5	PGND	Power Ground
6	C1 -	External Capacitor -
7	C1 +	External Capacitor +
8	VOUT	Output

■ Block Diagram

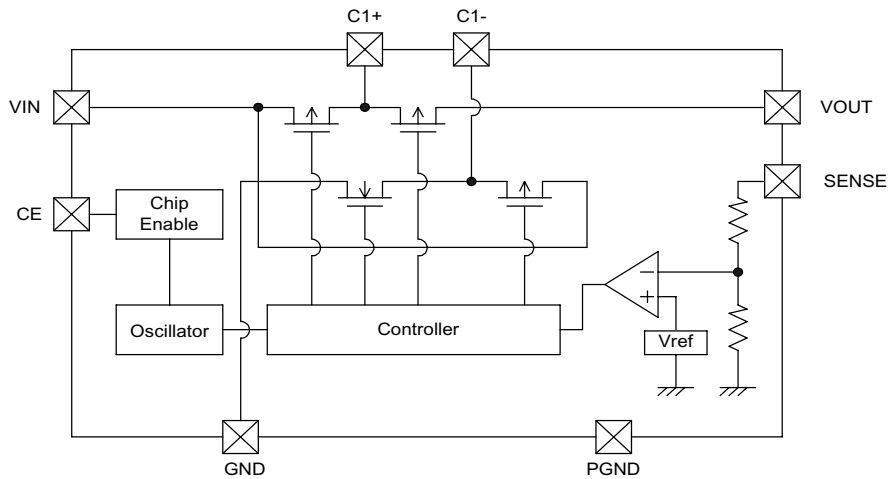

■ Absolute Maximum Ratings

Ta = 25°C, GND = 0V

PARAMETER	SYMBOL	CONDITIONS	UNITS
VIN pin voltage	VIN	-0.3 ~ 6	V
VOUT pin voltage	VOUT	-0.3 ~ 12	V
C1 + pin voltage	C1+	-0.3 ~ VOUT + 0.3	V
C1 - pin voltage	C1-	-0.3 ~ VOUT + 0.3	V
CE pin voltage	VCE	-0.3 ~ VIN + 0.3	V
VOUT pin output current	IOUT	200	mA
Power dissipation	Pd	150	mW
Operating Temperature	Topr	- 40 ~ + 80	°C
Storage Temperature	Tstg	- 40 ~ + 125	°C

■ Electrical Characteristics

XC9801B503KR VOUT=5.0V

Ta=25°C

PARAMETER	SYMBOL	CONDITIONS		MIN.	TYP.	MAX.	UNITS
Output Voltage	VOUT	Regulation Output	IOUT=1mA	4.875	5.0	5.125	V
Load Regulation	ΔVOUT	Regulation Output	1mA ≤ IOUT ≤ 80mA		50	100	mV
Operating Voltage Range	VIN	Doubler Output, VOUT > VIN × 2 × 0.95		1.8		5.5	V
Supply Current	IDD	No External Components, SENSE = 0V, VOUT open			1		mA
Stand-by Current	ISTB	CE=0V				2.0	μA
Oscillator Frequency	FOSC	External Component : CIN, SENSE=0V, VOUT open		255	300	345	kHz
Output Impedance	ROUT	Doubler Output	IOUT=10mA		20	40	Ω
Input Current	IIN	Doubler Output			5		mA
	IIN2	Regulation Output			1.5		mA
Voltage Converting Efficiency	VEFF1	Doubler Output		98	99		%
Power Converting Efficiency	EFF1	Doubler Output	IOUT=10mA		78		%
	EFF12	Regulation Output	IOUT=1mA		40		%
	EFF13		IOUT=80mA		69		%
CE / 'H' Level Voltage	VCEH			1.5			V
CE / 'L' Level Voltage	VCEL					0.25	V

Test Conditions : Unless otherwise stated, VIN=3.6V, GND=0V, CE=VIN, No Load

XC9802B503KR VOUT=5.0V

Ta=25°C

PARAMETER	SYMBOL	CONDITIONS		MIN.	TYP.	MAX.	UNITS
Output Voltage	VOUT	Regulation Output	IOUT=1mA	4.875	5.0	5.125	V
Load Regulation	ΔVOUT	Regulation Output	1mA ≤ IOUT ≤ 80mA		50	100	mV
Operating Voltage Range	VIN	Doubler Output, VOUT > VIN × 2 × 0.95		1.8		5.5	V
Supply Current	IDD	No External Components, SENSE = 0V, VOUT open			1		mA
Stand-by Current	ISTB	CE=0V				2.0	μA
Oscillator Frequency	FOSC	External Component : CIN, SENSE=0V, VOUT open		255	300	345	kHz
Switching Pulse Frequency	FOSC2	Regulation Output	IOUT=1mA		3.6		kHz
Output Impedance	ROUT	Doubler Output	IOUT=10mA		20	40	Ω
Input Current	IIN	Doubler Output			5		mA
	IIN2	Regulation Output			0.08		mA
Voltage Converting Efficiency	VEFF1	Doubler Output		98	99		%
Power Converting Efficiency	EFF1	Doubler Output	IOUT=10mA		78		%
	EFF12	Regulation Output	IOUT=1mA		65		%
	EFF13		IOUT=80mA		69		%
CE / 'H' Level Voltage	VCEH			1.5			V
CE / 'L' Level Voltage	VCEL					0.25	V

Test Conditions : Unless otherwise stated, VIN=3.6V, GND=0V, CE=VIN, No Load

Preliminary

■ Typical Application Circuits

① Regulation Output

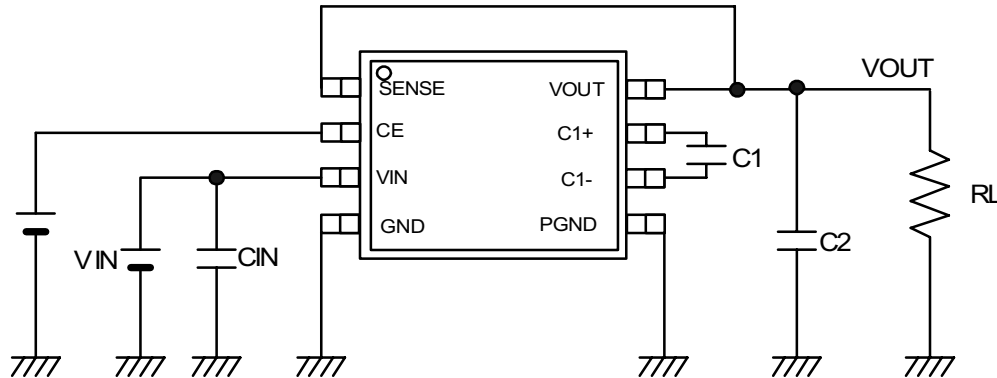

② Doubler Output

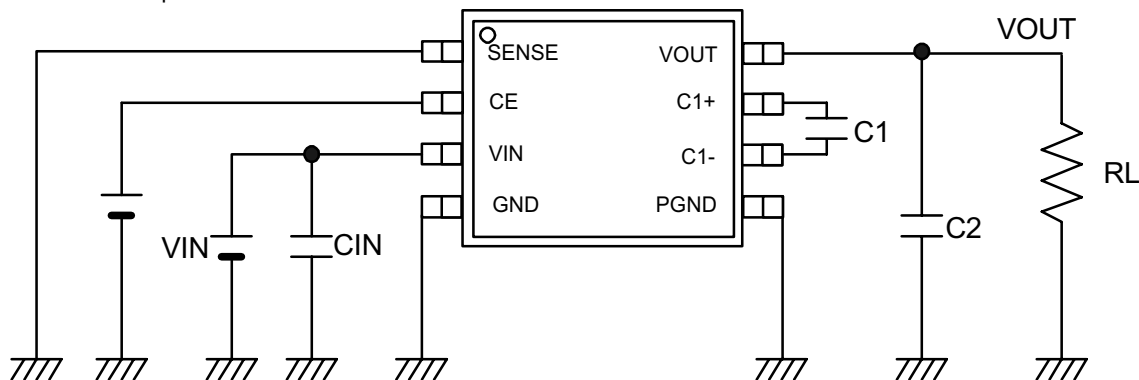

$C_{IN} = 1\mu F$

$C_1 = 0.47\mu F$

$C_2 = 4.7\mu F$

Note : The XC9801 series are step-up charge pump voltage doublers which provide regulated output voltage.

The application circuit of the doubler output (②) halts the regulated output function and operates as a normal voltage doubler.

The output voltage is stable when connected as in (①) above, except when $V_{IN} < (V_{OUT} / 2)$ and $V_{IN} \geq V_{OUT}$.

■XC9801 Electrical Data

1) Output Voltage vs. Output Current

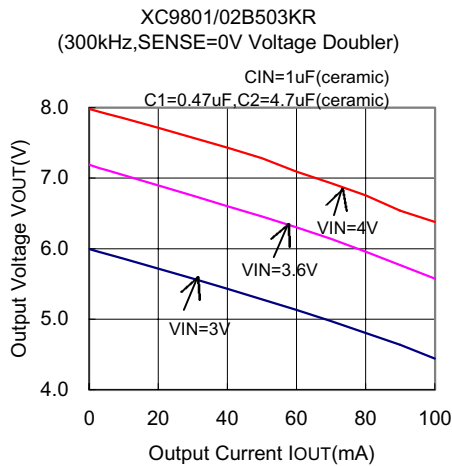
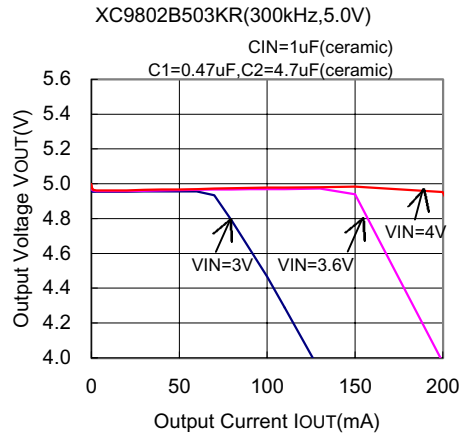
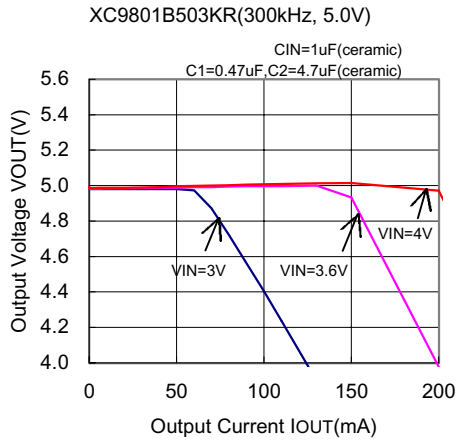

2) Efficiency vs. Output Current

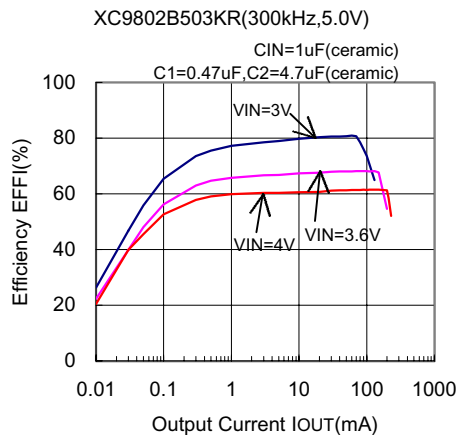
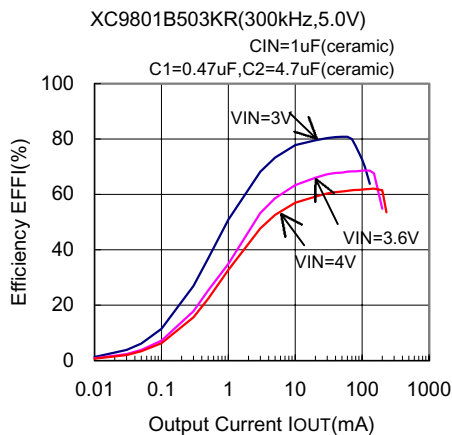

2) Efficiency vs. Output Current (continued)

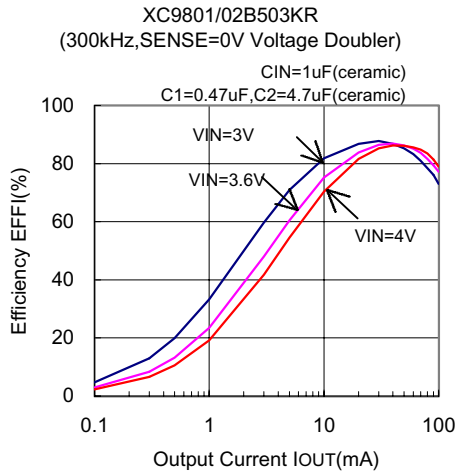

3) Output Current vs. Ripple Voltage

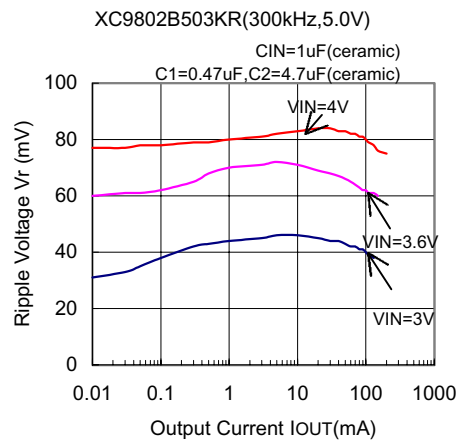
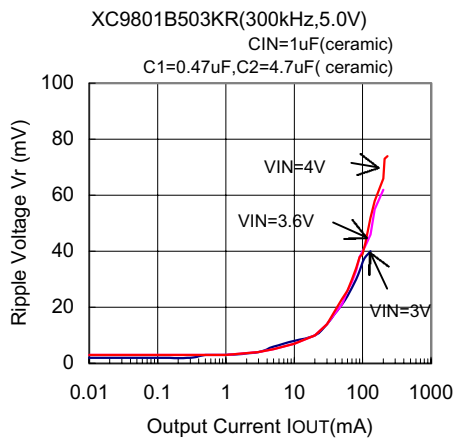

- Packaging Information (Dimensions : mm)
MSOP-8A : (1,000 pcs./reel)

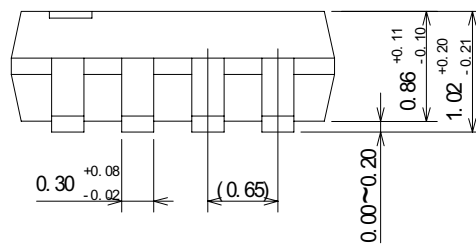
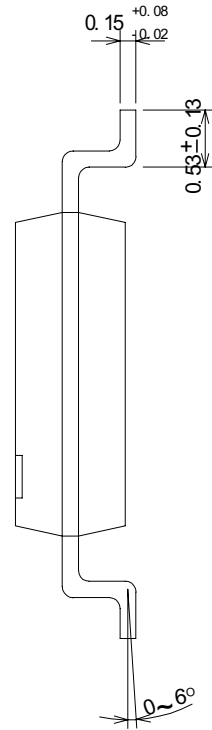
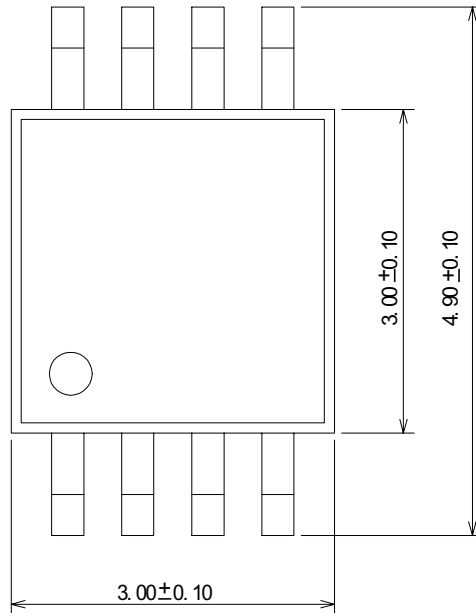

Preliminary

■ Recommended Pattern Layout (Dimensions : mm)

