

- Features:
- High intensity
 - Blue diffused (CD) or Water clear (WC) epoxy

LED Lamp Package

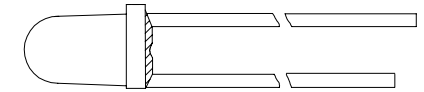

Electro / Optical Characteristics $I_F = 20 \text{ mA}$ (* 465 Blue - $I_F = 10 \text{ mA}$) $T_a = 25^\circ \text{ C}$

LED Part Number		Emitting Colour	Epoxy Type	Die Material	Wavelength		Forward Voltage V_F		Luminous intensity I_V		Luminous Flux ϕ_V	Viewing $\angle 2\theta_{1/2}$
Farnell	Forge Europa				Peak λ_P	Dominant λ_d	typical	max	min	typical		
366-4442	FNL-U300B07CDSL	488 Blue	CD	InGaN/SiC	488	490	3.70	4.20	-	180	-	60°
366-4454	FNL-U300B05CDSL	* 465 Blue	CD	InGaN/SiC	465	470	3.30	3.70	-	34	-	60°
366-4466	FNL-U300B06CDSL	458 Blue	CD	InGaN/SiC	458	460	3.70	4.20	-	70	-	60°
366-4478	FNL-U300B01CDSL	428 Blue	CD	InGaN/SiC	428	466	3.80	4.50	-	24	-	60°
366-4480	FNL-U300B07WCSL	488 Blue	WC	InGaN/SiC	488	490	3.70	4.20	-	910	-	35°
366-4491	FNL-U300B05WCSL	* 465 Blue	WC	InGaN/SiC	465	470	3.30	3.70	-	170	-	35°
366-4508	FNL-U300B06WCSL	458 Blue	WC	InGaN/SiC	458	460	3.70	4.20	-	360	-	35°
366-4510	FNL-U300B01WCSL	428 Blue	WC	InGaN/SiC	428	466	3.80	4.50	-	120	-	35°
Units					nm		V		mcd		mlm	deg

Maximum Ratings $T_a = 25^\circ \text{ C}$ (Derate above 25° C)

Characteristic	Condition	Symbol	Rating	Units
Pulse Forward Current	0.1 duty cycle @ 1KHz (465 Blue)	I_{FP}	100 (35)	mA
DC Forward Current	(465 Blue)	I_F	25 (15)	mA
Reverse Voltage	$I_R = 100 \mu\text{A}$	V_R	5	V
Power Dissipation		P_D	85	mW
Operating Temperature		T_{opr}	- 20 to + 80	° C
Storage Temperature		T_{stg}	- 20 to + 100	° C
Lead soldering temperature	1.6 mm from body - max 3 seconds		240	° C

Note

Industry standard procedures regarding static must be observed when handling product produced with blue die material.

Package Outline

Dimensions in mm

Tol ± 0.25 mm unless stated



WARNING

This range of LEDs is produced with die having a high radiant flux. Care must be taken when viewing the product at close range as the light may be intense enough to cause damage to the human eye.

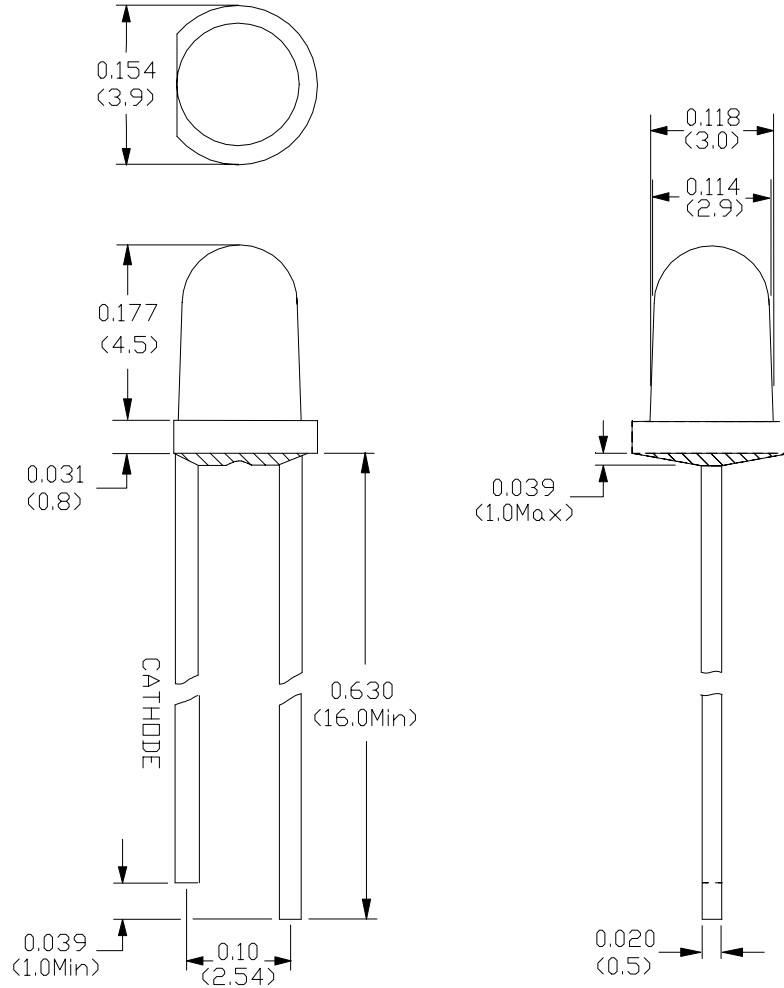

Radiation Diagrams

T_a = 25°C

35°

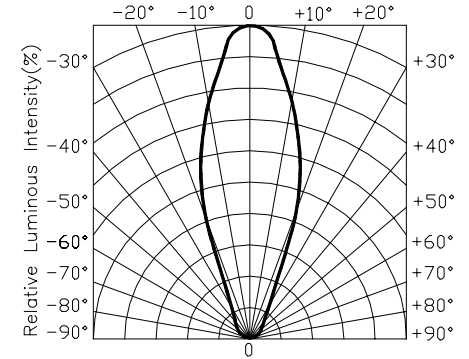

60°

