

För icke direkt toleranssatta mått gäller toleransklass  
General tolerances if not otherwise stated

NOM DIM MM		TOL CLASS		
From	To	A	B	C
(1)	6	±0.05	±0.1	±0.2
(6)	30	±0.1	±0.2	±0.5
(30)	100	±0.15	±0.3	±0.8
(100)	300	±0.2	±0.5	±1.2
(300)	1000	±0.3	±0.8	±2

Hål / Holes H13

Skarpa kanter brutna där ej annat anges.  
No sharp edges unless otherwise specified.

Övriga generella toleranser enligt ritning 4100-4644.  
Additional general tolerances in accordance with drawing 4100-4644.

LASERMÄRKNING/LASER MARKING:

TEXTFONT: GEN-ISO

Datumkod / Date code "YYYYYY"

Serienummer / Serial number "XXXXXXX"

Rev	Change order	Change: A = Added W = Was D = Deleted C = Changed	Date	Sign
4	1055368000	C 4101-6507N 1044635001 W 1044635000	111025	SE

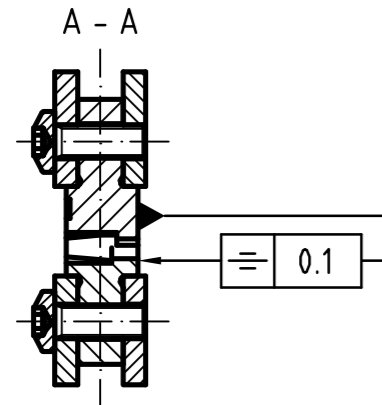
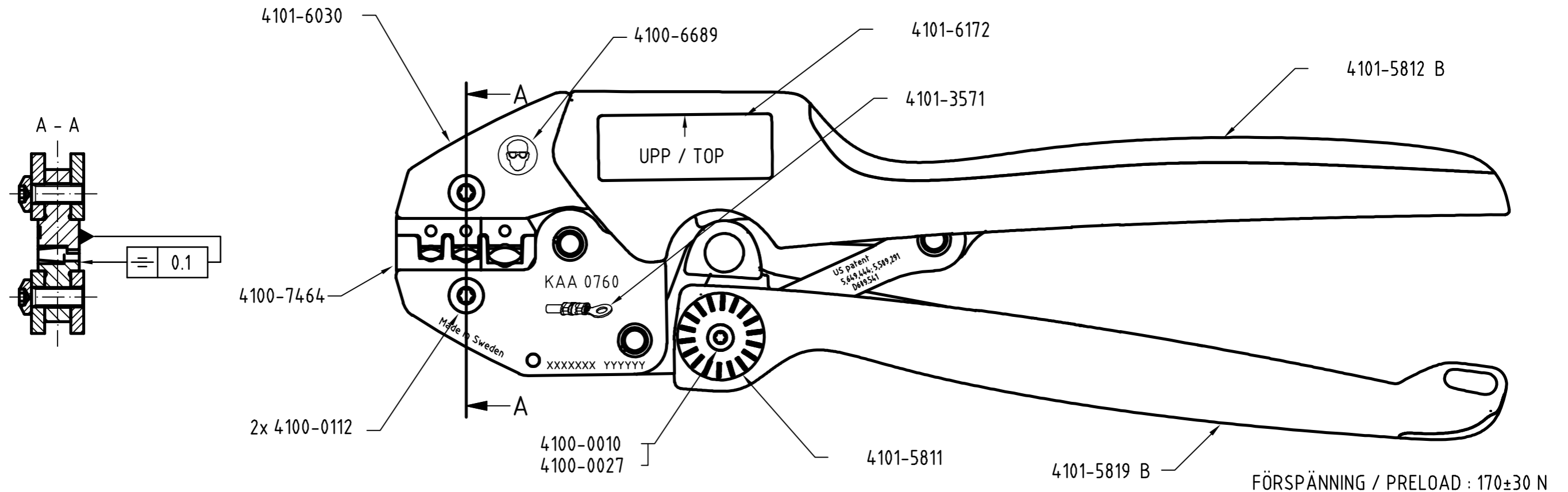

4101-2610  
4101-5828  
4101-6507 N - placering position A  $\triangle$   
4101-6301  
TILLTRYCK PÅ KORT (4101-6301) ENLIGT OMT DOKUMENT NR.:1044635001  $\triangle$   
PRINTING ON CARD (4101-6301) ACCORDING TO OMT DOCUMENT NO.:1044635001  $\triangle$

TOLKMÅTT / GAUGE DIMENSIONS :		
URTAG NEST	GÅTOLK GO	STOPPTOLK NO GO
RÖD/RED	∅ 2.36	∅ 2.56
BLÅ/BLUE	∅ 2.56	∅ 2.76
GUL/YELLOW	∅ 3.55	∅ 3.75

Packas enligt förpackningsritning 4101-2741  
Packed according to drawing 4101-2741

Material		Behandling/Treatment			Status	
Konstr/Design MANO	Ritad/Drawn MANO	Datum/Date 2011-10-25	Skala/Scale 1:1	Kontr/Checked IP	Godk/Approved NE	Änne/Blank Frisläppt
<b>pressmaster</b> ®				Benämning/Denomination Krimptång KAA 0760		Vikt/Veigt,gram Art grp 012
ISO 9001 REG NR FM13647				CRIMPING TOOL		Ritn nr./Drawing no 43003686 REV 004

Den här ritning är Pressmaster AB:s egendom. Skyddad av gällande lag.  
This drawing is the property of Pressmaster AB. Protected in accordance with prevailing law.