

- 1 HOUSING: NYLON OR POLYESTER, FLAME RETARDANT, UL 94V-0 RATED, GLASS FILLED, BLACK.
CONTACTS: BRASS.
SHELL: CARBON STEEL.
EYELETS: BRASS.
BOARDLOCKS: COPPER ALLOY.
- 2 SHELL: 2.54µm[.000100] MIN TIN OVER 1.27µm[.000050] MIN COPPER.
EYELETS: 5.08µm[.000200] MIN TIN OVER COPPER FLASH.
CONTACTS: SEE TABLE.
BOARDLOCKS: 5.08µm[.000200] MIN TIN OVER 1.27µm[.000050] MIN NICKEL.
INSERTS: CLEAR CHROMATE.
SCREWLOCKS: CLEAR CHROMATE.
- 3 GOLD FLASH ON THE MATING SURFACES, 2.54µm[.000100] MIN TIN PLATE ON THE SOLDER END, 1.27µm[.000050] MIN NICKEL UNDERPLATE ON THE ENTIRE CONTACT.
- 4 0.76µm[.000030] MIN GOLD PLATE ON THE MATING SURFACES, 2.54µm[.000100] MIN TIN PLATE ON THE SOLDER END, 1.27µm[.000050] MIN NICKEL UNDERPLATE ON THE ENTIRE CONTACT -OR- GOLD FLASH OVER PALLADIUM-NICKEL PLATE, 0.76µm[.000030] MIN TOTAL ON THE MATING SURFACES, 2.54µm[.000100] MIN TIN PLATE ON THE SOLDER END, 1.27µm[.000050] MIN NICKEL UNDERPLATE ON THE ENTIRE CONTACT.
- 5 DIMENSION APPLIES FROM CENTER OF CONTACTS.

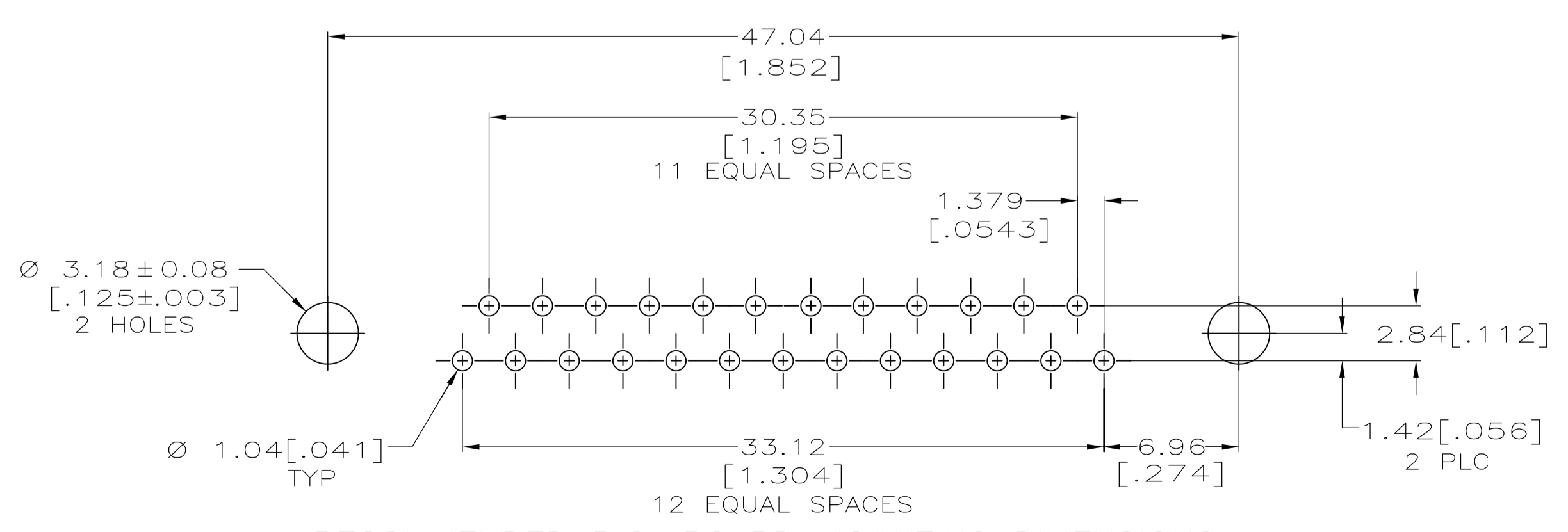
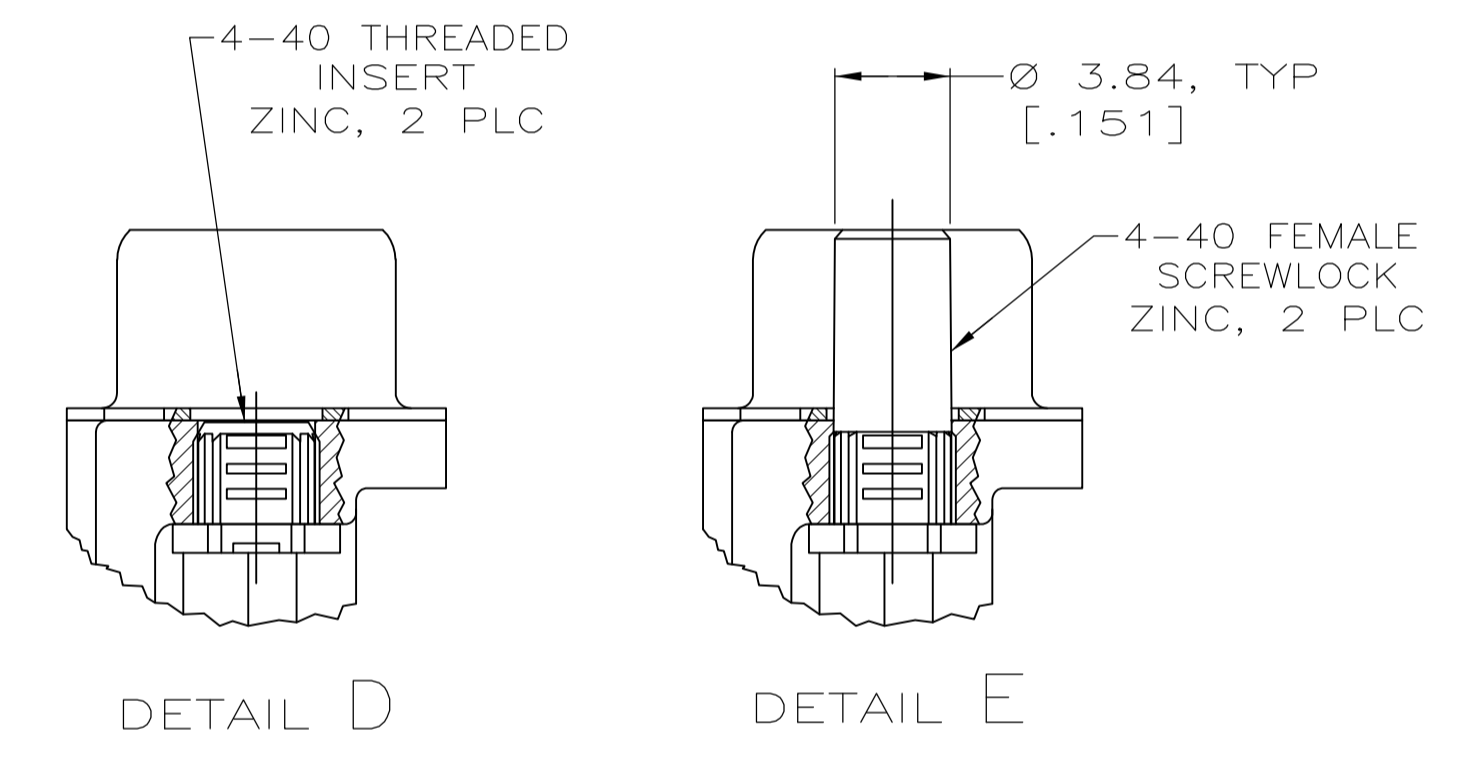
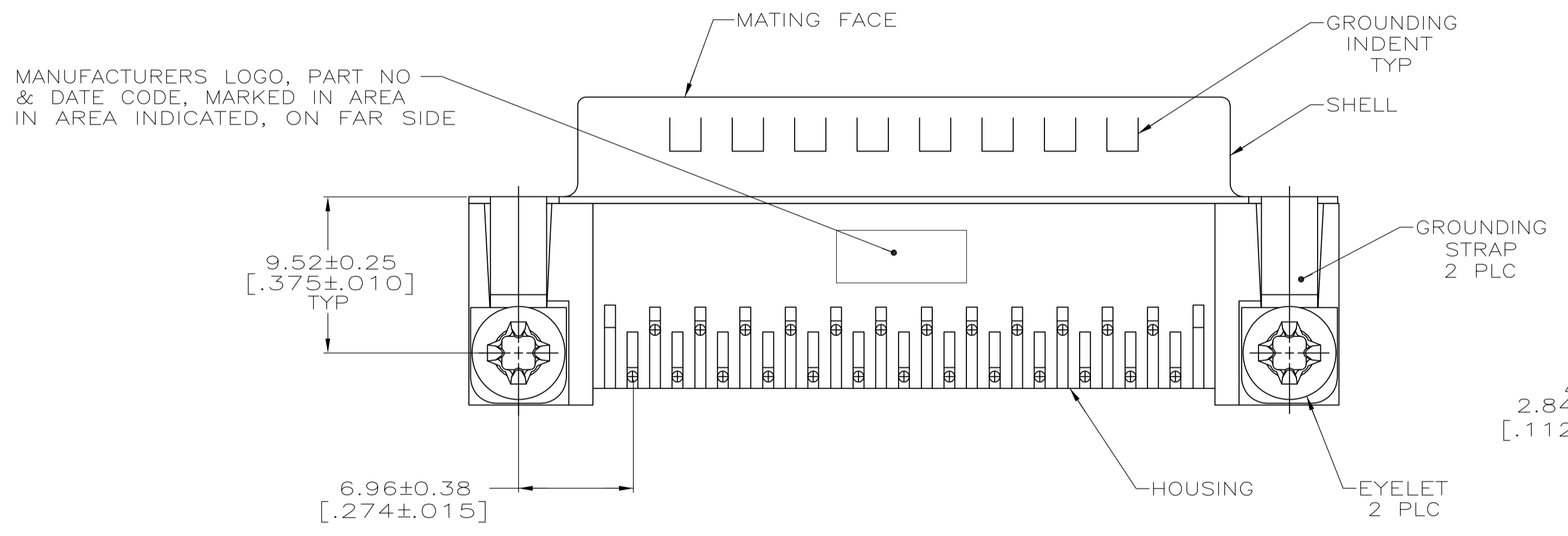

RECOMMENDED P.C. BOARD MOUNTING DIMENSIONS
P.C. BOARD THICKNESS: 1.57[.062]

**COPYRIGHT 2005
TYCO ELECTRONICS CORP
ALL RIGHTS RESERVED**

SEE DETAIL E	4	5747842-6
SEE DETAIL D	3	5747842-5
	4	5747842-4
	3	5747842-3
	4	5747842-2
MOUNTING HARDWARE	CONTACT FINISH	PART NO

THIS DRAWING IS A CONTROLLED DOCUMENT.		DIN G. ATTADIA - 04-12-05		TE Connectivity	
DIMENSIONS: INCHES		CHK S. BOLASH 04-12-05		NAME M. WALMSLEY 04-12-05	
TOLERANCES UNLESS OTHERWISE SPECIFIED:		APVD		PRODUCT SPEC	
0 PLC	± .005	108-40025		PLUG ASSEMBLY, SIZE 3, 25 POSITION, RIGHT ANGLE, FRONT METAL SHELL, .318 SERIES, BOARDLOCKS, AMPLIMITE HD-20	
1 PLC	± .005	APPLICATION SPEC		SIZE 114-40010	
2 PLC	± .010	DRAWING NO		RESTRICTED TO	
3 PLC	± 0.13[.005]	114-40010		A1 00779	
4 PLC	± .010	WEIGHT		SCALE 4:1 SHEET 1 OF 1 REV B	
ANGLES	± .2°	CUSTOMER DRAWING			