

THIS DRAWING IS UNPUBLISHED. RELEASED FOR PUBLICATION  
 © COPYRIGHT - By - ALL RIGHTS RESERVED.

LOC		DIST		REVISIONS			
P	LTR	DESCRIPTION		DATE	DWN	APVD	
AD	00	A2	REVISED PER ECO-14-000321		10JAN2014	NK	RH

SPECIFICATIONS:

MATERIALS:

CASE: LCP UL94V-0, BLACK  
 COVER, NICKEL SILVER ALLOY-PLATE SILVER OVER NICKEL.  
 ACTUATOR: NYLON 46 UL94V-0, BLACK  
 MOVING CONTACT: COPPER ALLOY-PLATE SILVER OVER NICKEL  
 FIXED CONTACT/TERMINAL, COPPER ALLOY-PLATE SILVER OVER NICKEL  
 SPRING PLATE, STAINLESS STEEL-PLATE SILVER OVER NICKEL

ELECTRICAL:

CONTACT RATING: 300mA@4VDC.  
 INITIAL CONTACT RESISTANCE, 70 MILLIOHMS MAX.  
 FINAL CONTACT RESISTANCE, 100 MILLIOHMS MAX.  
 INSULATION RESISTANCE: 100 MEGAOHMS MIN.  
 DIELECTRIC STRENGTH: 100 VAC FOR 1 MINUTE.  
 LIFE EXPECTANCY: 10,000 CYCLES.

MECHANICAL:

ACTUATION FORCE: 150±70 gf.  
 ACTUATION TRAVEL, 1.50±0.15  
 LIFE EXPECTANCY, 10,000 CYCLES.

ENVIRONMENTAL:

OPERATING TEMPERATURE, -20 TO +85 DEGREES C  
 STORAGE TEMPERATURE, -40 TO +100 DEGREES C  
 HUMIDITY, MIL-STD-202, METHOD 103, CONDITION B  
 MOISTURE RESISTANCE, MIL-STD-202, METHOD 106  
 THERMAL SHOCK, MIL-STD-202, METHOD 107, CONDITION A  
 SOLDERABILITY, PER EIA-364-52, CLASS 2, CATEGORY 1,  
 95%MINIMUM COVERAGE  
 RESISTENCE TO SOLDER HEAT, 109-201, CONDITION B

NOTES:

- ALL MATERIALS AND FINISHES SHALL COMPLY WITH EU DIRECTIVE 2002/95/EC OF 27JAN2003(ROHS).
- TAPE AND REEL PACKAGING PER EIA-481, TAPE WIDTH 16mm, PITCH 8mm AND 3300 pcs PER REEL.

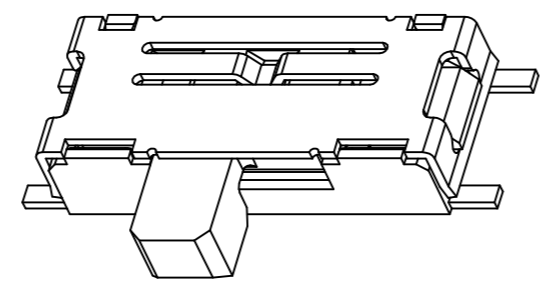
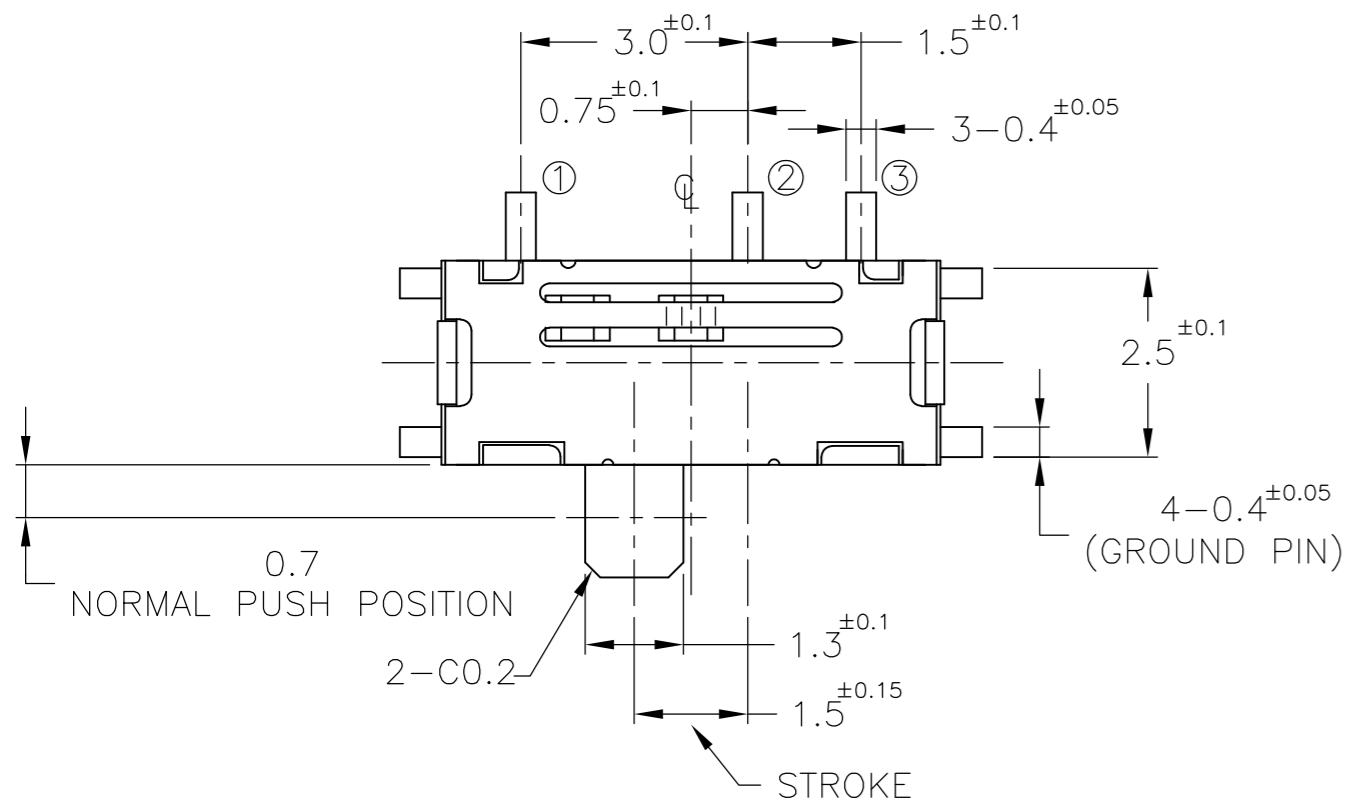

SCHEMATIC (1P2T)

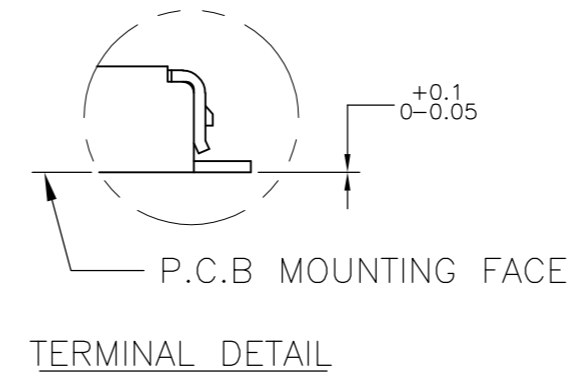
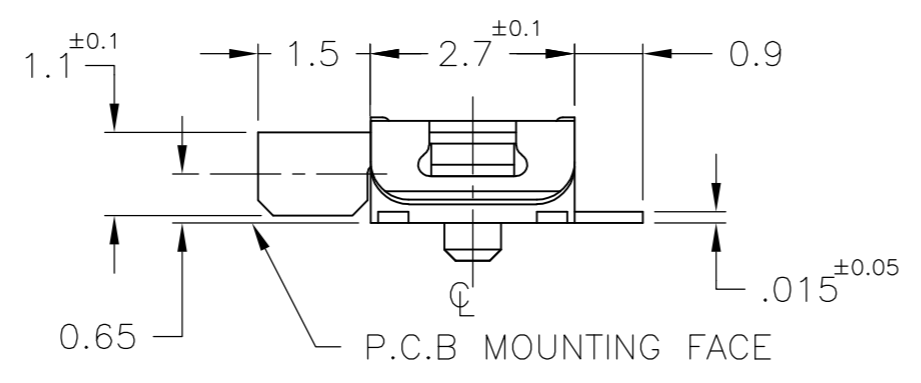
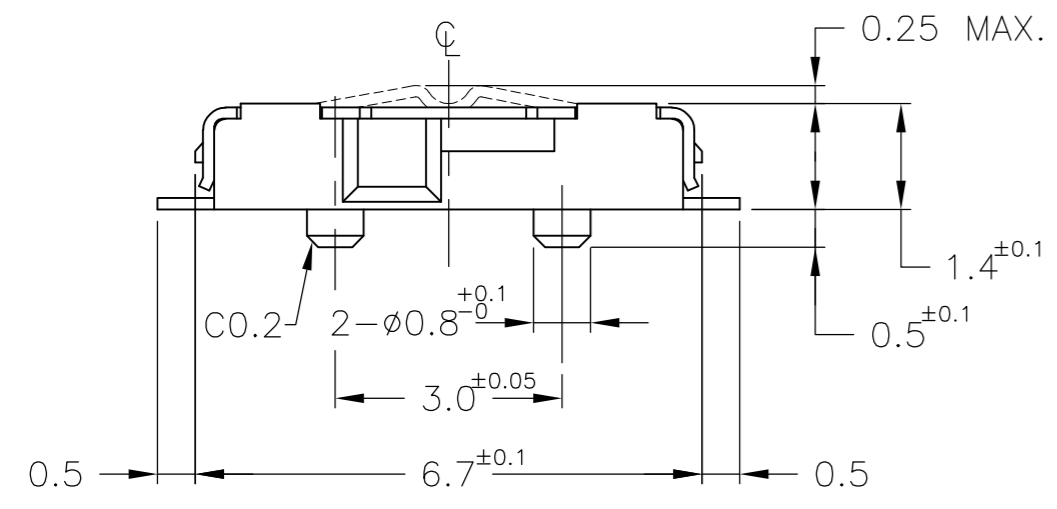
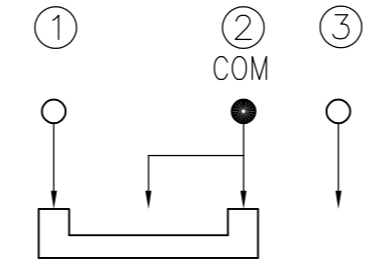

P.C.B LAYOUT

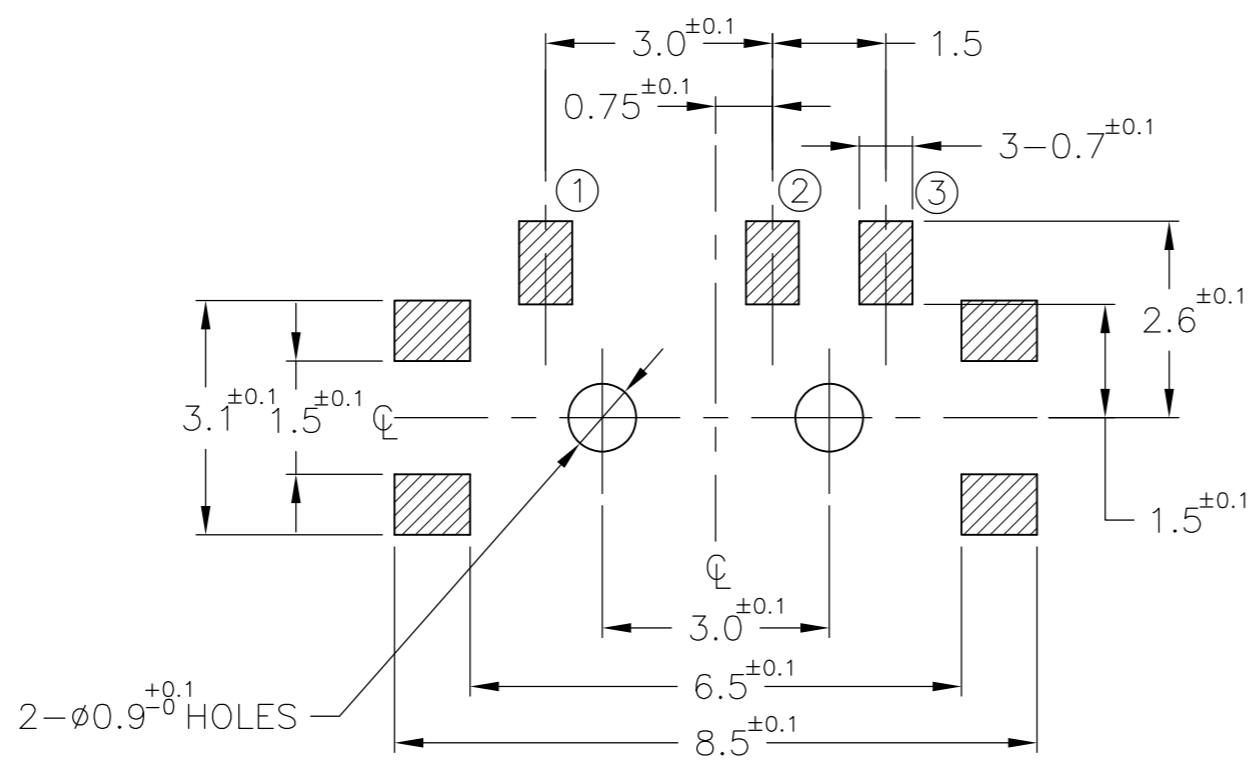

8MM	16MM	3,300	T&R	MLL1200STR	1437575-2
N/A	N/A	N/A	BULK	MLL1200S	1437575-1
PITCH	TAPE WIDTH	QTY per Reel	PKG	ALCO P/N	PART NO.

THIS DRAWING IS A CONTROLLED DOCUMENT.		DWN	R BROWN	04DEC01		TE Connectivity						
DIMENSIONS: mm		CHK	H WYNKOOP	04DEC01		NAME						
TOLERANCES UNLESS OTHERWISE SPECIFIED:		APVD	H WYNKOOP	04DEC01		PRODUCT SPEC						
0 PLC ± - 1 PLC ± - 2 PLC ± 0.13 3 PLC ± - 4 PLC ± - ANGLES ± -		APPLICATION SPEC		SLIDE SWITCH SPDT,R/A LOW PROFILE SMT								
MATERIAL		WEIGHT	-		SIZE	A2	CAGE CODE	00779	DRAWING NO	C=1437575-1	RESTRICTED TO	-
FINISH		CUSTOMER DRAWING		SCALE	10:1	SHEET	1 of 1	REV	A2			