

THIS DRAWING IS UNPUBLISHED. RELEASED FOR PUBLICATION
 © COPYRIGHT - BY - ALL RIGHTS RESERVED.

LOC		DIST		REVISIONS			
P	LTR	DESCRIPTION	DATE	DWN	APVD		
B		REV PER ECO 13-001557	2-12-13	CT	DM		

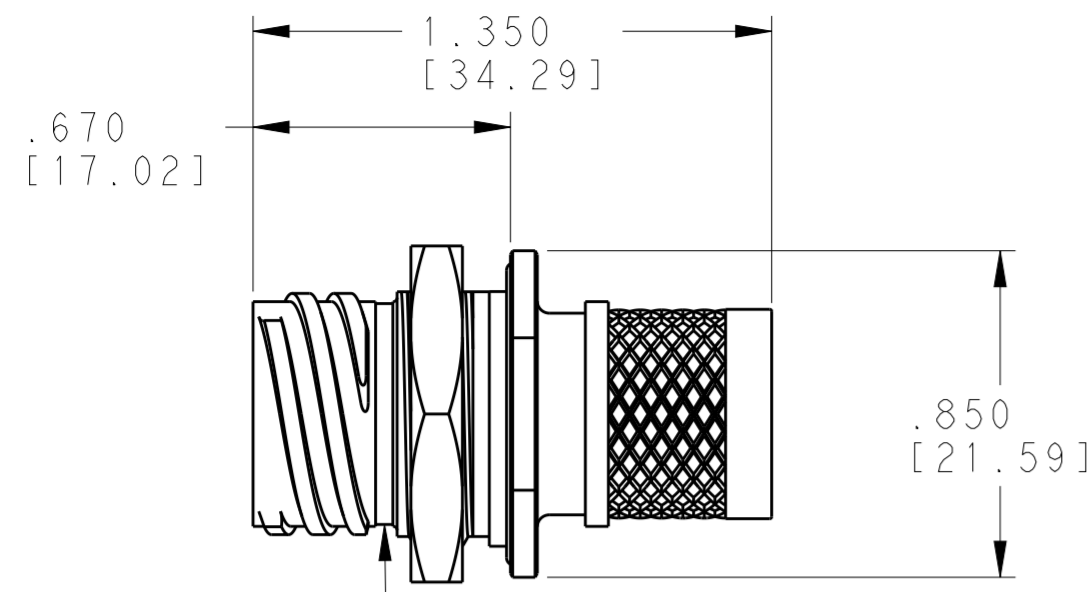

RED FULL MATE INDICATOR

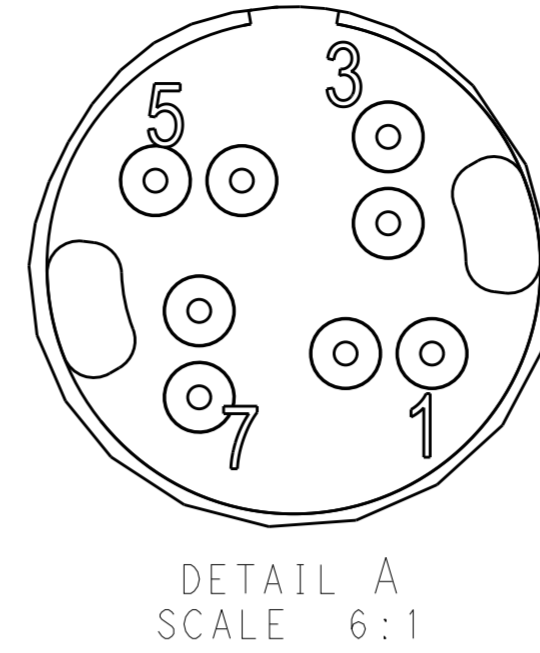
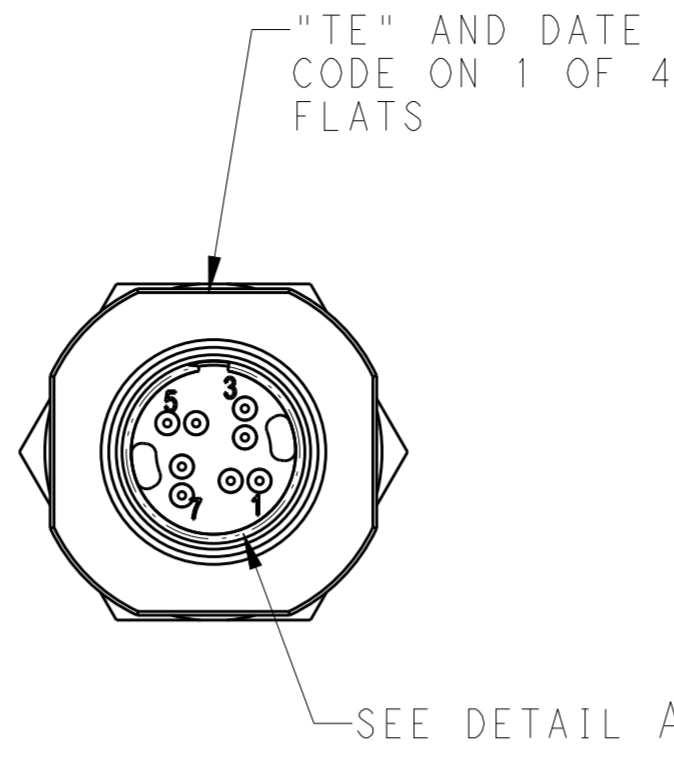

KEY OPTION	KEY ROTATION	
	"R"	"S"
NORMAL	150°	210°
A	140°	215°
B	132°	248°

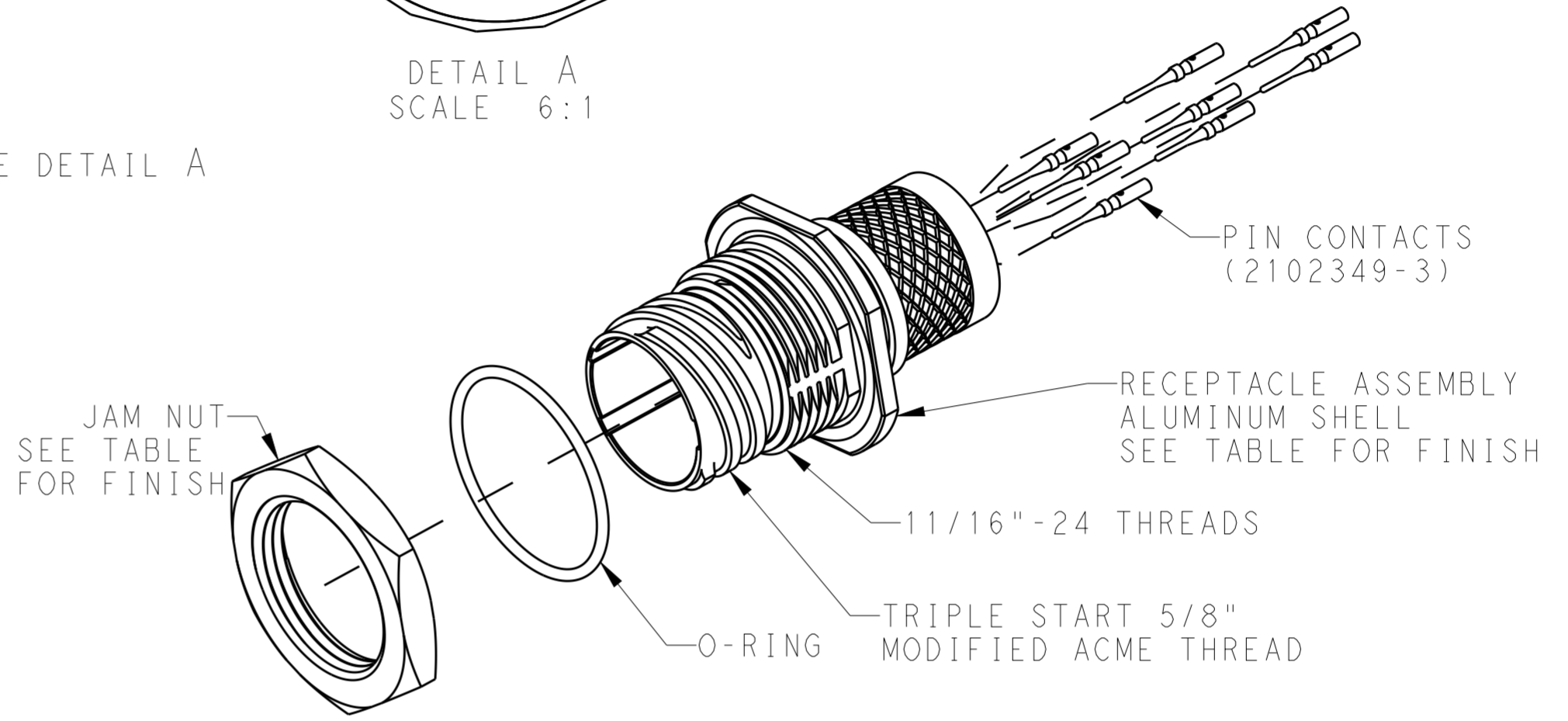
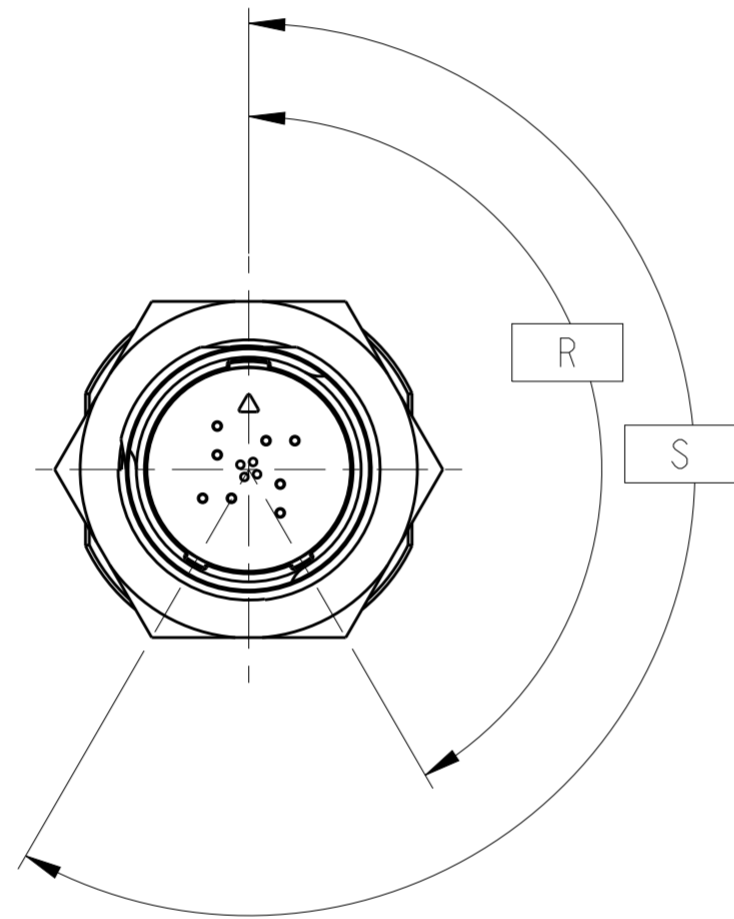

- 1, -3 AND -5 ARE ELECTROLESS NICKEL PLATE PER MIL-C-26074.
- 2, -4 AND -6 ARE BLACK ZINC NICKEL PER AMS-2417.
- O-RING AND NUT ARE ASSEMBLED TO SHELL. CONTACTS SHALL BE PACKAGED SEPARATELY IN KIT.

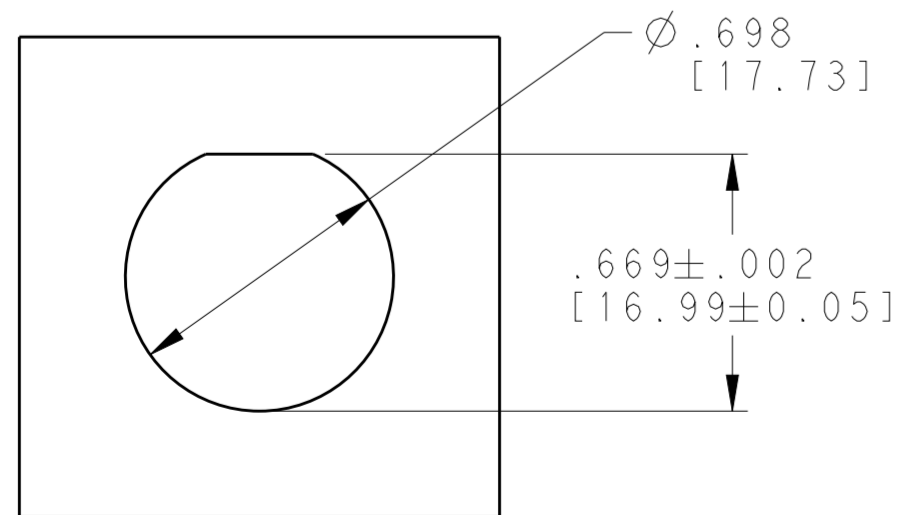

1	-	1	10	B	BLACK ZINC NICKEL PLATE	2102352-6
-	1	1	10	B	NICKEL PLATE	2102352-5
1	-	1	10	A	BLACK ZINC NICKEL PLATE	2102352-4
-	1	1	10	A	NICKEL PLATE	2102352-3
1	-	1	10	NORMAL	BLACK ZINC NICKEL PLATE	2102352-2
-	1	1	10	NORMAL	NICKEL PLATE	2102352-1
JAM NUT BLACK ZINC NICKEL PLATE	JAM NUT NICKEL PLATE	O-RING FLUOROSILICONE	PIN CONTACT 50µ GOLD PLATE	KEYING OPTION	FINISH	PART NUMBER

THIS DRAWING IS A CONTROLLED DOCUMENT. DIMENSIONING AND TOLERANCING PER ASME Y14.5M (ISO STANDARDS)

DIMENSIONS: INCHES [mm]

TOLERANCES UNLESS OTHERWISE SPECIFIED:

0 PLC	±
1 PLC	±
2 PLC	±
3 PLC	±.005 [0.13]
4 PLC	±
ANGLES	±
FINISH	±

MATERIAL: -

DWN: MCKIBBEN, JOHN 09 JUN 2011
 CHK: DOWHOWER, KENNETH 09 JUN 2011
 APVD: DOWHOWER, KENNETH 09 JUN 2011

PRODUCT SPEC: 108-2482
 APPLICATION SPEC: 114-32025
 WEIGHT: -

STE TE Connectivity

NAME: RECEPTACLE ASSEMBLY KIT

SIZE: A2 CAGE CODE: 00779 DRAWING NO: C-2102352 RESTRICTED TO: -

CUSTOMER DRAWING SCALE: 2:1 SHEET 1 OF 1 REV B