

This document is the property of Amphenol Corporation and is delivered on the express condition that it is not to be disclosed, reproduced or used, in whole or in part, for manufacture or sale by anyone other than Amphenol Corporation without its prior consent, & that no right is granted to disclose or to use any information in this document.

REVISIONS				
SYM	ECN	DESCRIPTION	DATE	APPROVED
A	HK	PRELIMINARY RELEASE	10/23/03	Y.M.LEE
A2HK		ADD CHOP OF ROHS	1/11/07	IP

# CUSTOMER INFORMATION DRAWING

TABLE 1

CONNECTOR SIZES	AVERAGE MATING FORCE (POUNDS)
14	5
24	8
36	12
50	15
64	19

SPECIFICATIONS:

- 1) SOLDER CUP CONTACT: TO ACCOMMODATE 22-30 AWG SOLID AND 24-30 STRANDED CONNECTOR WIRES.
- 2) DIELECTRIC: DIALYL-PHTHALATE PER MIL-M-14F TYPE MDG UL-94V0
- 3) CONTACT MATERIAL: COPPER ALLOY
- 4) CONTACT: 20 MICRO-INCHES MIN. GOLD MATING AREA: 3-5 MICRO-INCHES GOLD TERMINATION AREA: 50 MICRO-INCHES MIN. NICKEL UNDERPLATING ALL OVER
- 5) SHELL MATERIAL: ZINC PLATED STEEL WITH CLEAR CHROMATE COATING
- 6) CURRENT CAPACITY: 5 AMPS/CONTACT
- 7) VOLTAGE RATING: 700 VOLTS D.C. AT SEA LEVEL  
200 VOLTS D.C. AT 70,000 FEET
- 8) INSULATION RESISTANCE: >5000 M OHM
- 9) DIELECTRIC WITHSTANDING VOLTAGE: 1200 VAC (RMS) AT SEA LEVEL
- 10) CONNECTOR MATING FORCE: REFER TO TABLE 1.
- 11) CONTACT RETENTION FORCE: 2 LBS MAX.
- 12) DURABILITY: 250 CYCLES MIN.
- 13) VIBRATION: NO INTERRUPTIONS < 1u SEC.
- 14) OPERATING TEMPERATURE: -55°C TO +105°C (-67°F TO +221°F)

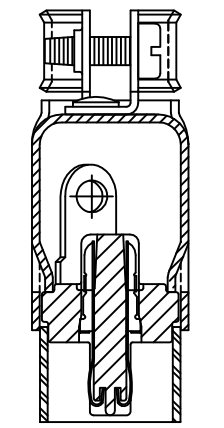

SECTION A-A

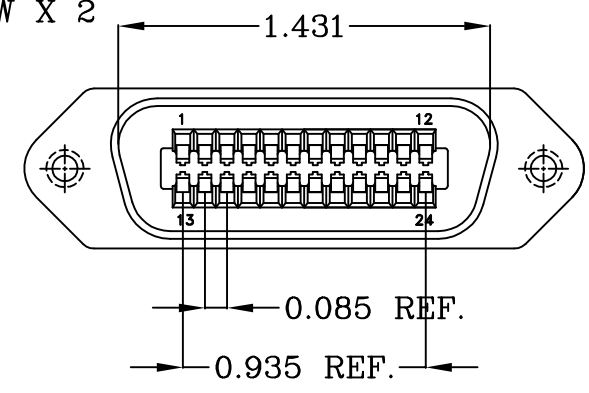
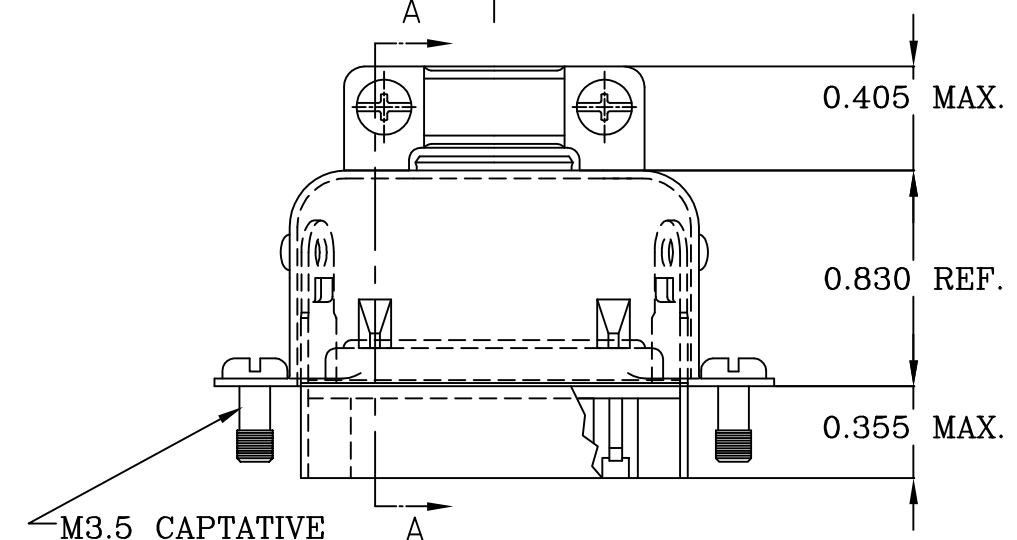
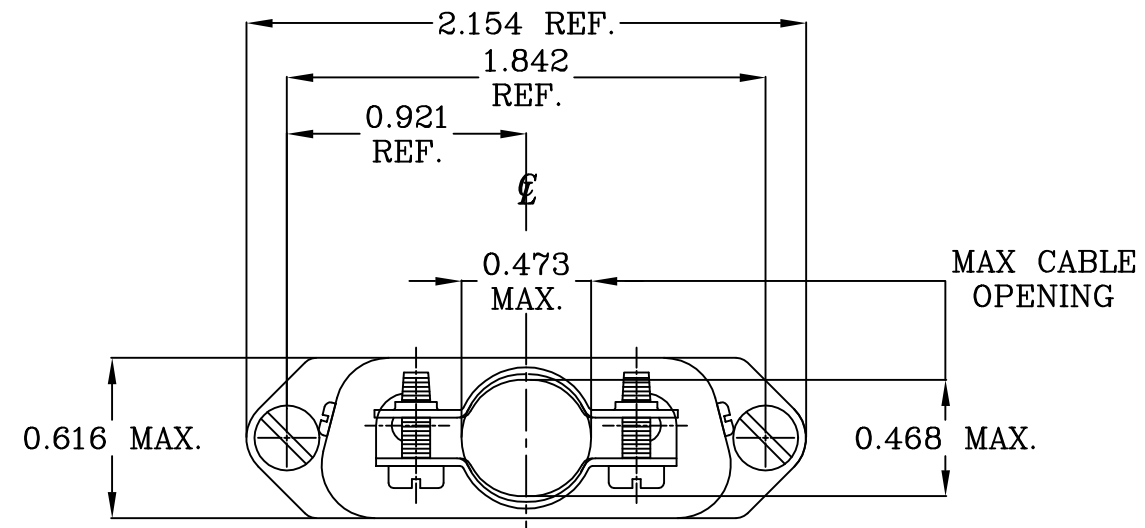

UNLESS OTHERWISE SPECIFIED TOLERANCES U.S. METRIC .X +/- 0.020 .XX +/- 0.010 .XXX +/- 0.005 FRACTIONS +/- ANGLES +/- 1°	APPROVAL	DATE	Amphenol
	DRAWN XS.GUO	1/11/07	
FOR MATERIALS AND FINISHES SEE NOTES	CHECKED		TITLE
REMOVE SHARP EDGES	CHECKED		24 CONTACT CABLE MOUNTED ASSEMBLY WITH M3.5 SCREWS
DIMENSIONS	ANGLE OF PROJECTION		SIZE DRAWING NO.
U.S. INCHES			A3 C57-33240-1
(METRIC) (MM)			SCALE NONE SHEET 1 OF 1