

ITEM NO.	WIRE GAUGE (AWG)	WIRE GAUGE (METRIC)	PLATING
172063-0311	14 OR 16 AWG	1.5mm ²	15 GOLD
172063-0312	12 AWG	4.0 OR 2.5mm ²	15 GOLD
172063-1311	14 OR 16 AWG	1.5mm ²	30 GOLD
172063-1312	12 AWG	4.0 OR 2.5mm ²	30 GOLD
76823-0321	14 OR 16 AWG	1.5mm ²	TIN
76823-0322	12 AWG	4.0 OR 2.5mm ²	TIN

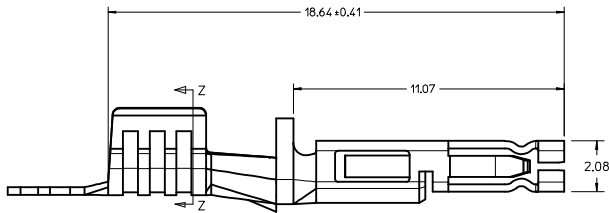

76823-0321 SHOWN

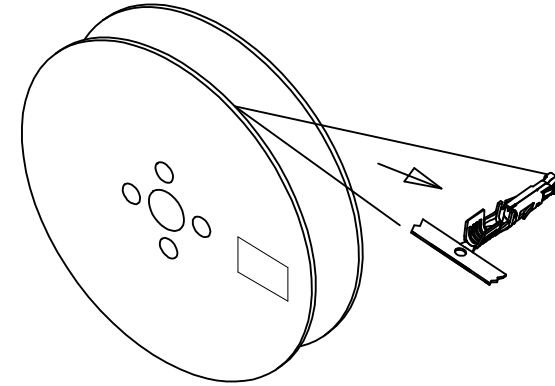
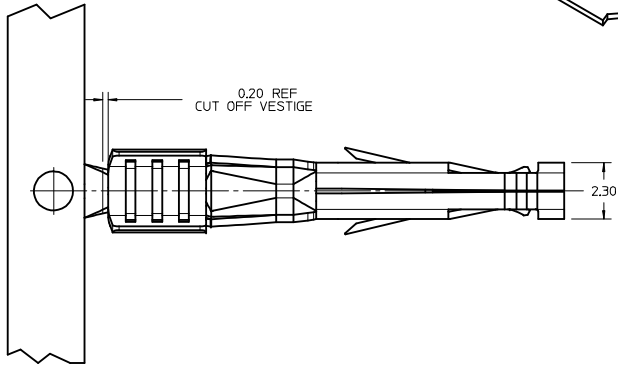
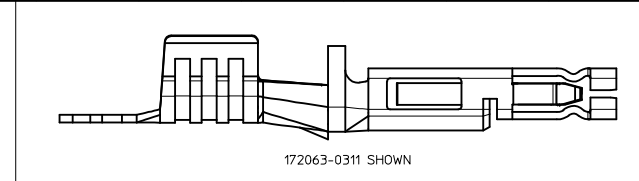
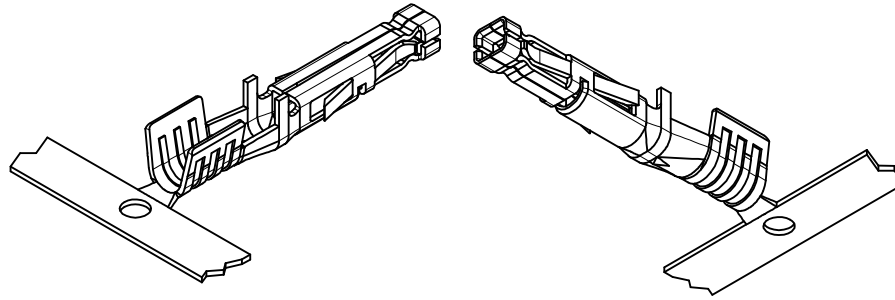
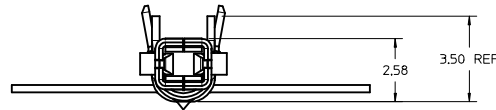

NOTES:

- MATERIAL: HIGH CONDUCTIVITY COPPER ALLOY
- FINISH:
 (TIN) 1.52 MICROMETER / (60 MICRONINCH) MINIMUM REFLOWED MATTE TIN OVER
 1.27 MICROMETER / (50 MICRONINCH) MINIMUM NICKEL. LUBRICANT ADDED TO CONTACT INTERFACE
 (15 GOLD) 0.38 MICROMETER / (15 MICRONINCH) MINIMUM SELECT GOLD AND
 2.54 MICROMETER / (100 MICRONINCH) MINIMUM SELECT MATTE TIN OVER
 1.27 MICROMETER / (50 MICRONINCH) MINIMUM NICKEL OVERALL
 (30 GOLD) 0.76 MICROMETER / (30 MICRONINCH) MINIMUM SELECT GOLD AND
 2.54 MICROMETER / (100 MICRONINCH) MINIMUM SELECT MATTE TIN OVER
 1.27 MICROMETER / (50 MICRONINCH) MINIMUM NICKEL OVERALL.
- PRODUCT SPECIFICATION: PS-76823-100
- PACKAGING PER PK-76823-001.
- TERMINAL FOR USE WITH 170001 & 171692 SERIES RECEPTACLES.
- APPLICATION SPECIFICATION: AS-76823-100
- PART CONFORMS TO CLASS 'B' REQUIREMENTS OF COSMETIC SPECIFICATION PS-45499-002.

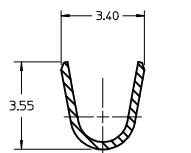

SECTION Z-Z
CONDUCTOR CRIMP 14/16 AWG

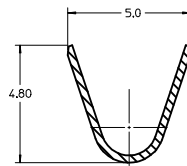

SECTION Z-Z
CONDUCTOR CRIMP 12 AWG

ADD VIEW FOR GOLD EEC NO. UCP2015-2840 DRAWN BY: CHYK APPR:FSMTH 2015/02/04 2015/02/05	QUALITY SYMBOLS	GENERAL TOLERANCES (UNLESS SPECIFIED)	DIMENSION STYLE	SCALE	DESIGN UNITS	THIRD ANGLE PROJECTION
	▽=0	mm INCH	MM ONLY	10:1	METRIC	☉
	▽=0	4 PLACES ± --- ± ---	DRAWN BY DATE	TITLE		
	▽=0	3 PLACES ± --- ± ---	CHKD: DATE	FEMALE CRIMP TERMINAL MEGA-FIT		
	1 PLACE ± 0.25 ± ---	APPROVED BY DATE	MATERIAL NO. DOCUMENT NO.			
	0 PLACE ± 0.36 ± ---	DATE	SEE CHART SD-76823-0100			
		ANGULAR ±1/2°	SHEET NO.			
		DRAFT WHERE APPLICABLE MUST REMAIN WITHIN DIMENSIONS	1 OF 1			
			THIS DRAWING CONTAINS INFORMATION THAT IS PROPRIETARY TO MOLEX INCORPORATED AND SHOULD NOT BE USED WITHOUT WRITTEN PERMISSION			