

REVISIONS				
ZONE	REV	DESCRIPTION	DATE	APPROVED
	A	ECN 0755	12-NOV-14	

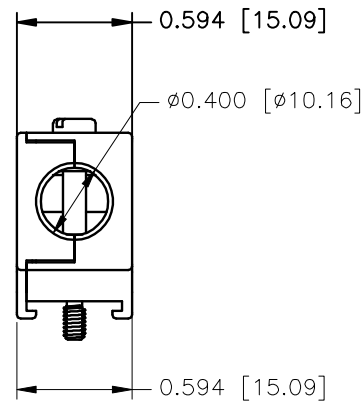

NO LOGO

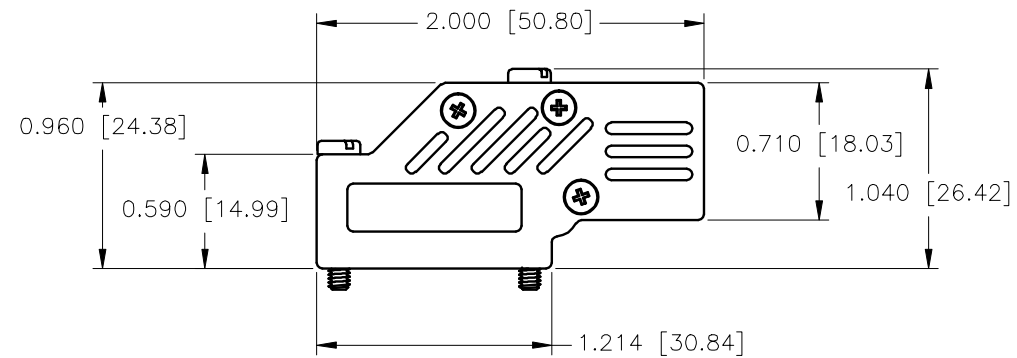
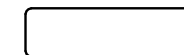

PART NUMBER INFORMATION

PART#	LOGO STYLE	SUPPLIED
NA30E900000	NO LOGO TOP COVER	BULK
NA30E900100	BOTTOM COVER	BULK
N30E900000	NO LOGO	PACKAGED

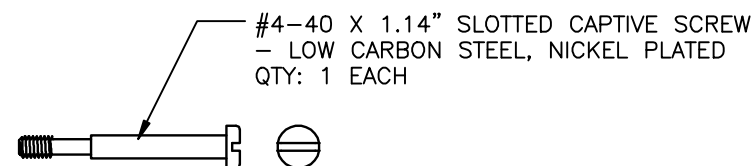
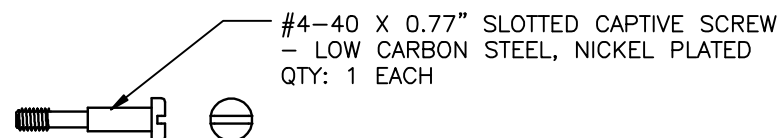
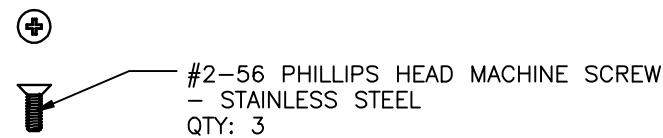
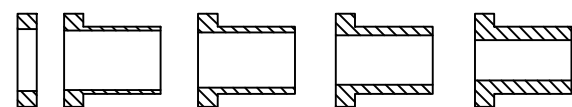
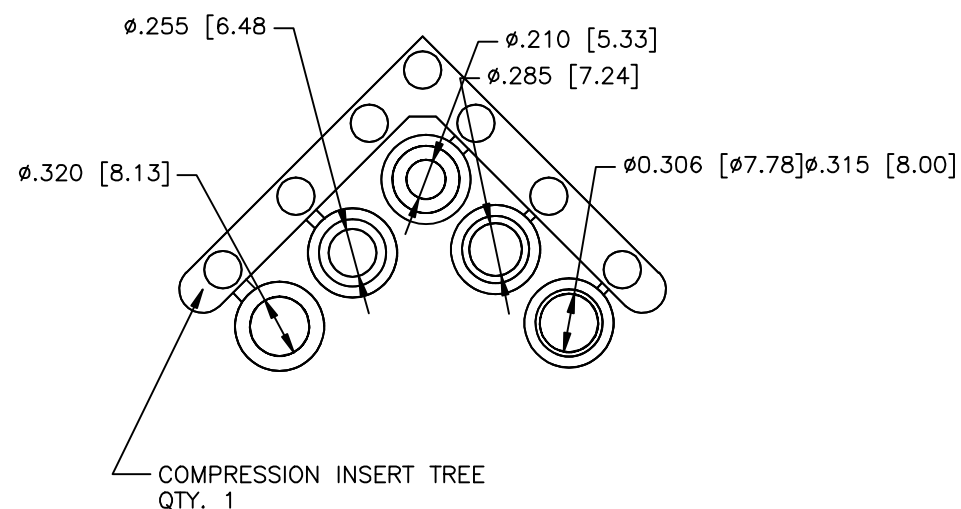
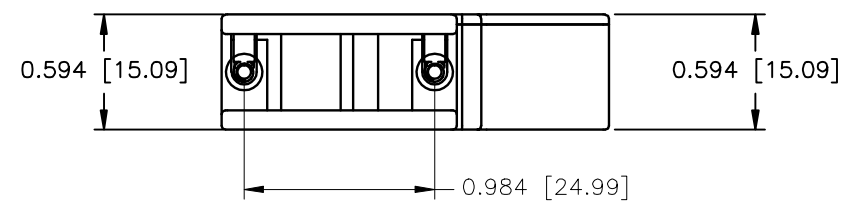

CONNECTOR COVER:

- 1.MATERIAL: ZINC ALLOY
- 2.FINISH: NICKEL PLATING PER NTC SPECIFICATION N/T 000400
- 3.DIMENSIONS: INCHES [MM]
- 4.TOLERANCE: ±0.015 [0.381]

COMPRESSION INSERT TREE

- 1.MATERIAL: THERMOPLASTIC
- 2.COLOR: BLACK
- 3.DUROMETER: 75 ±5 TYPE A PER ASTM D2240
- 4.DIMENSIONS: INCHES [MM]
- 5.TOLERANCE: ±0.020 [0.508]

THIS IS A CONTROLLED DOCUMENT AND IS SUBJECT TO CHANGE. CONTACT NORTHERN TECHNOLOGIES ENGINEERING FOR THE LATEST REVISION.

UNLESS OTHERWISE SPECIFIED 1. ALL DIMENSIONS ARE IN INCHES (MM) 2. DIMENSIONS ARE TYPICAL		<b>Northern Technologies</b>		
DRAWN JSD		PART NUMBER SEE PART NUMBER INFORMATION DESCRIPTION CM 09 90 DEGREE ULTRA LOW PROFILE		
CHECKED SCN		SIZE B	CODE 200_169	DWG NO. 0002-200-169
ISSUED		SCALE 1:1		REV
02-JAN-06		02-JAN-06		0002-200-169
02-JAN-06		SHEET 1 OF 1		