

6

5

4

3

2

1

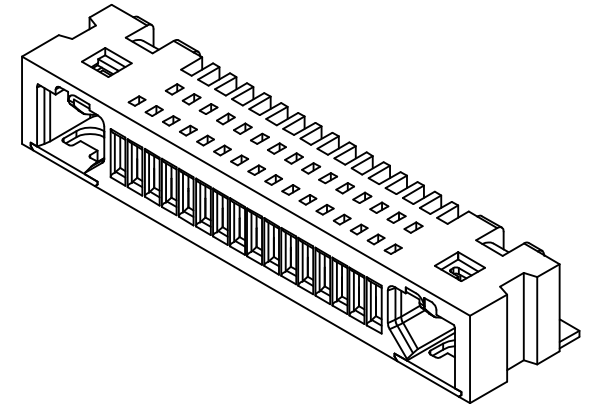
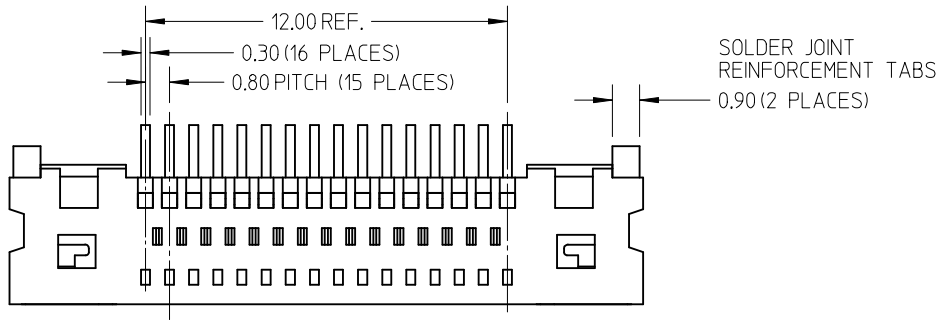

NOTES:

1. MATERIALS: HOUSING - GLASS-REINFORCED THERMOPLASTIC, UL94V-0, COLOR: BLACK.
TERMINALS - COPPER ALLOY
2. FINISHES: CONTACT SURFACES - SELECTIVE GOLD OVER PALLADIUM-NICKEL OVER NICKEL
SOLDERING SURFACES - TIN OVER NICKEL
3. PRODUCT SPECIFICATION: PS-44828-001
APPLICATION SPECIFICATION: AS-44828-001
4. CO-PLANARITY OF THE SOLDER TAILS TO BE 0.10 MAXIMUM.
5. PACKAGING: EMBOSSED TAPE AND REEL, PACKAGING SPECIFICATION PK-44828-001.

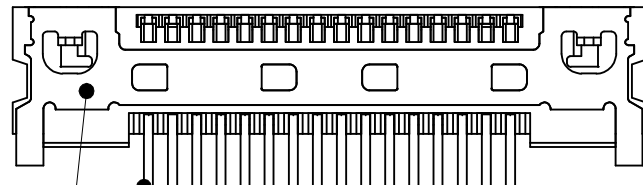
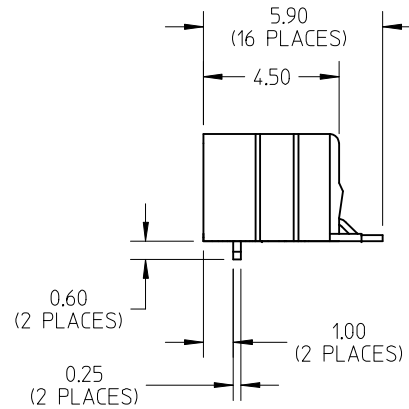
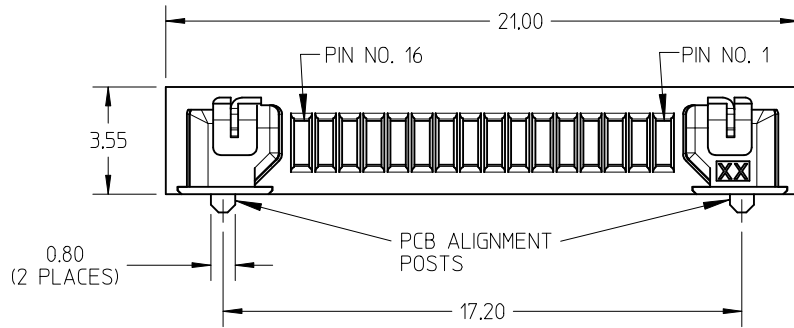

448281162	16 CIRCUIT WITH PCB ALIGNMENT POST.	1000
MATERIAL NO.S	DESCRIPTION	PARTS PER REEL

UPDATE GEOMETRY EC NO: UCP2015-4283 DRWN:DMORGAN 2015/04/16 CHKD:BBARKER 2015/04/16 APPR:SMILLER 2015/04/27	QUALITY SYMBOLS 	GENERAL TOLERANCES (UNLESS SPECIFIED)		DIMENSION STYLE	SCALE	DESIGN UNITS	THIRD ANGLE PROJECTION	
				MM ONLY	4:1	METRIC		
				DRAWN BY	DATE	TITLE		
				MSIMMEL	2002/09/25	0.8MM HANDYLINK SMT RECEPTACLE 16 CIRCUIT		
		4 PLACES	± ---	± ---	CHECKED BY	DATE		
		3 PLACES	± ---	± ---	JCOMERCI	2002/09/26		
		2 PLACES	± 0.10	± ---	APPROVED BY	DATE		
		1 PLACE	± 0.10	± ---	SMILLER	2010/03/29		
		0 PLACE	±	±	MATERIAL NO.	DOCUMENT NO.		
		ANGULAR ±1/2°		SEE TABLE		SD-44828-001	SHEET NO.	
		DRAFT WHERE APPLICABLE MUST REMAIN WITHIN DIMENSIONS		SIZE	THIS DRAWING CONTAINS INFORMATION THAT IS PROPRIETARY TO MOLEX INCORPORATED AND SHOULD NOT BE USED WITHOUT WRITTEN PERMISSION			
				A				

5

4

3

2

1

**PACKAGING
DETAIL**

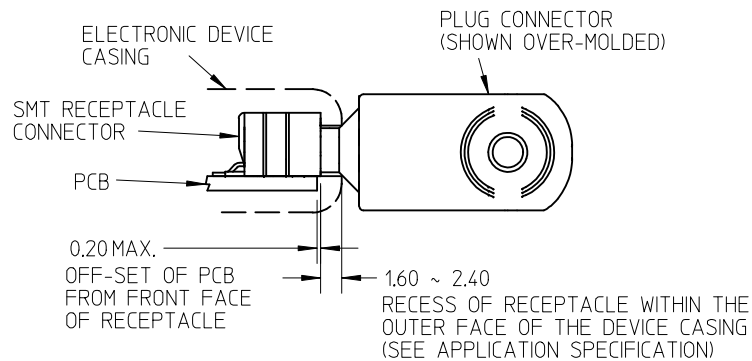
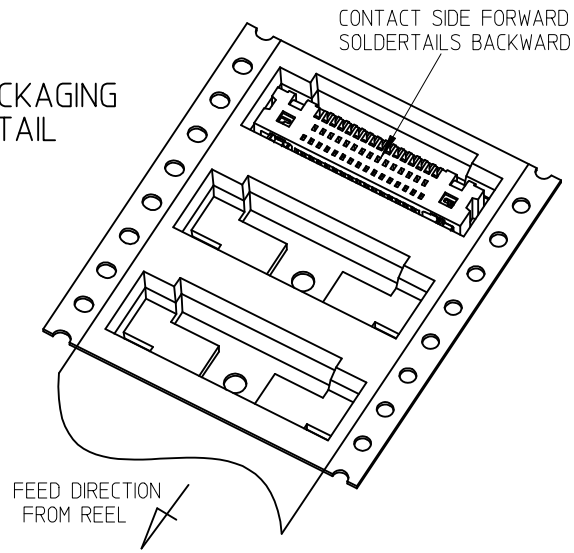

**RECOMMENDATIONS FOR CONFIGURATION
OF MATED CONNECTORS**

IMPORTANT: PLEASE REFER TO MOLEX APPLICATION SPECIFICATION AS-44828-001 FOR DETAILED DESIGN LAYOUT AND MATING REQUIREMENTS

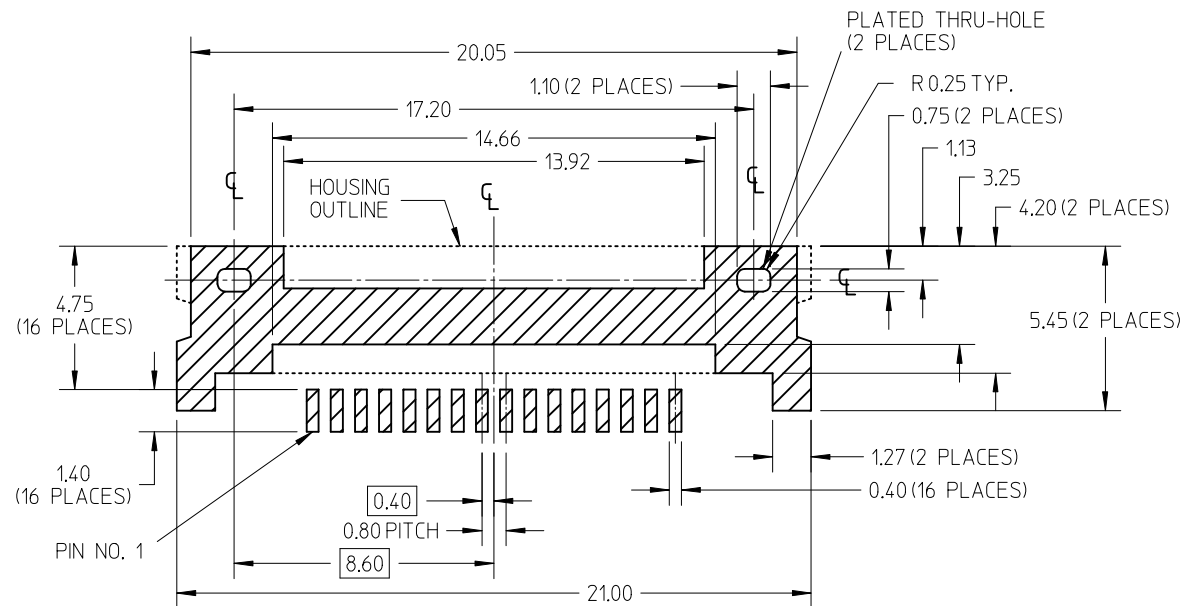

RECOMMENDED PCB PAD LAYOUT

NOTE: ALL DIMENSIONS TO BE SYMMETRIC ABOUT THE HOUSING CENTERLINE WITHIN 0.10

SEE SHEET 1 EC NO: UCP2015-4283 DRWN:DMORGAN 2015/04/16 CHKD:BBARKER 2015/04/16 APPR:SMILLER 2015/04/27	QUALITY SYMBOLS ≡ 0 ≡ 0 ≡ 0	GENERAL TOLERANCES (UNLESS SPECIFIED)		DIMENSION STYLE MM ONLY		SCALE 4:1	DESIGN UNITS METRIC	THIRD ANGLE PROJECTION	
			mm	INCH	DRAWN BY MSIMMEL	DATE 2002/09/25	TITLE 0.8MM HANDYLINK SMT RECEPTACLE 16 CIRCUIT		
		4 PLACES	± ---	± ---	CHECKED BY JCOMERC I	DATE 2002/09/26			
		3 PLACES	± ---	± ---	APPROVED BY SMILLER	DATE 2010/03/29	molex DOCUMENT NO. SD-44828-001 SHEET NO. 2 OF 2		
2 PLACES	± 0.10	± ---	MATERIAL NO. SEE TABLE						
1 PLACE	± 0.10	± ---	DRAFT WHERE APPLICABLE MUST REMAIN WITHIN DIMENSIONS		THIS DRAWING CONTAINS INFORMATION THAT IS PROPRIETARY TO MOLEX INCORPORATED AND SHOULD NOT BE USED WITHOUT WRITTEN PERMISSION				
0 PLACE	±	±							