

FREEDOM KV31F

Table of Contents

1	TITLE PAGE
2	BLOCK DIAGRAM
3	KV31 MCU
4	OpenSDA INTERFACE
5	ARDUINO SHIELDS

Revisions & Change Log

Rev	Description	Date	Approved
X1	Initial Draft	Jan 27	Mario Guardado

COMPRESSED IMAGE		Automotive, Industrial & Multi-Market Solutions Group 6501 William Cannon Drive West Austin, TX 78735-8598	
ICAP Classification: FCP: FIJO: PUB: X			
Designer: Roy Yang	Drawing Title: FRDM-KV31F		
Drawn by: Roy Yang	Page Title: TITLE PAGE		
Approved: Mario Guardado	Size C	Document Number	Rev X1
Date: Wednesday, January 28, 2015		Sheet 1 of 5	

- Unless Otherwise Specified:
 - All resistors are in ohms, most are 1%, 1/10 Watt. Otherwise are 5%, 1/8 Watt.
 - All capacitors are in uF, some are 10% or 20%
 - All voltages are DC
 - All polarized capacitors are tantalum
- Interrupted lines coded with the same letter or letter combinations are electrically connected.
- Device type number is for reference only. The number varies with the manufacturer.
- Special signal usage:
 - _B Denotes - Active-Low Signal
 - <> or [] Denotes - Vectored Signals
- Interpret diagram in accordance with American National Standards Institute specifications, current revision, with the exception of logic block symbology.

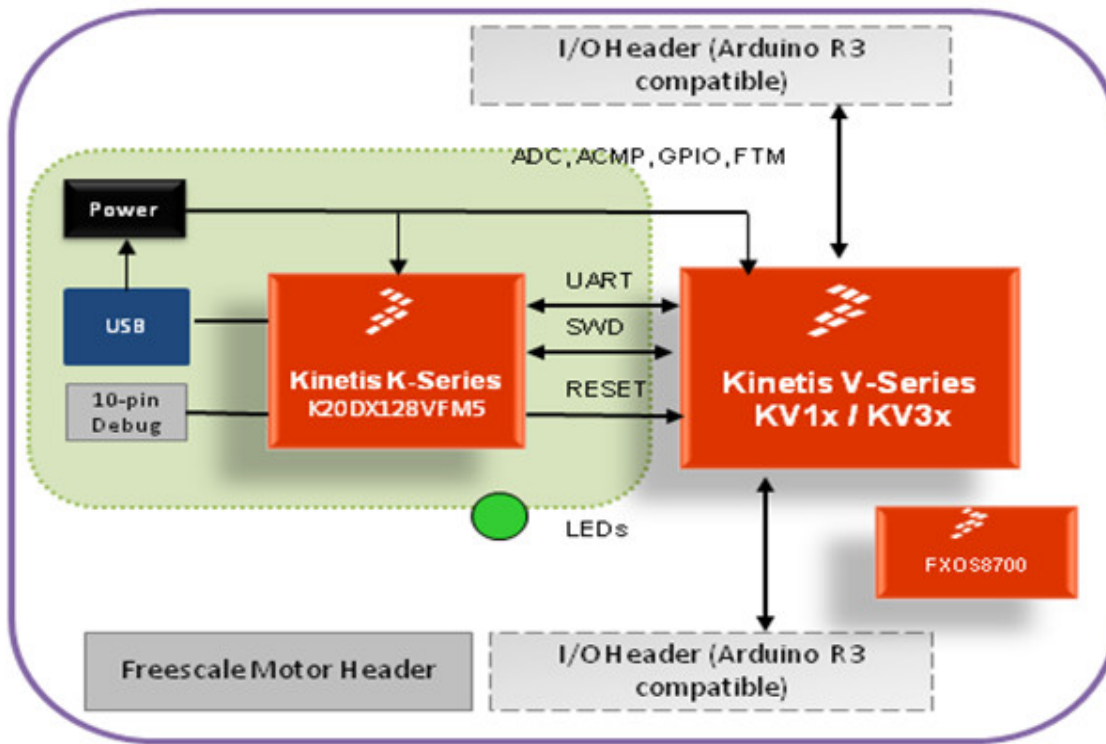

KV31 - 100LQFP

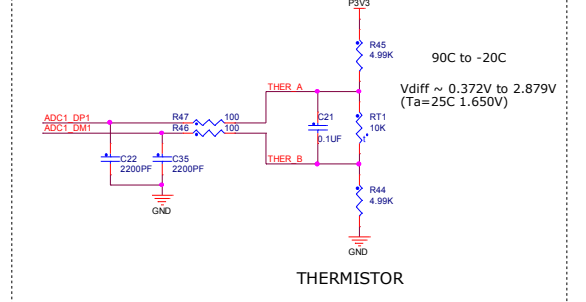
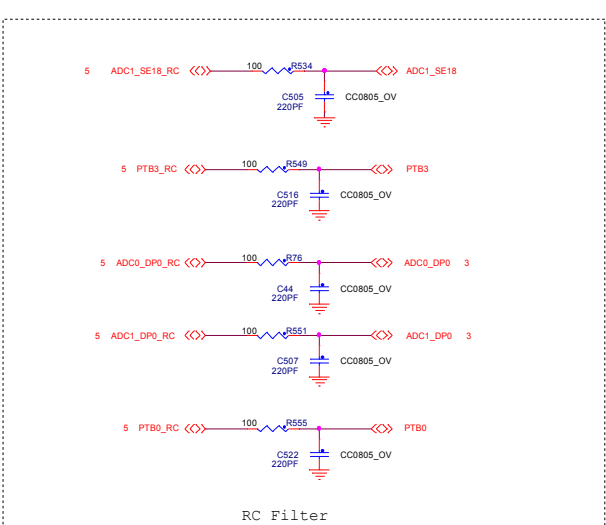
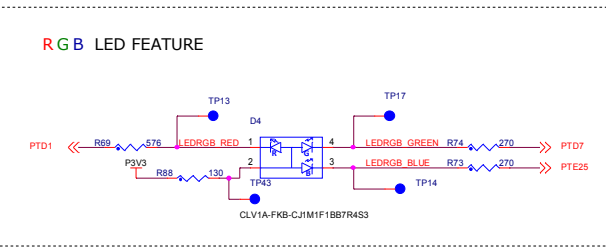
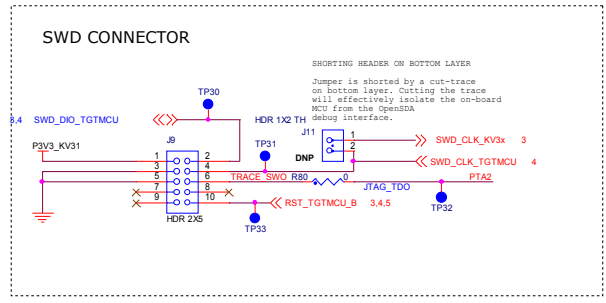
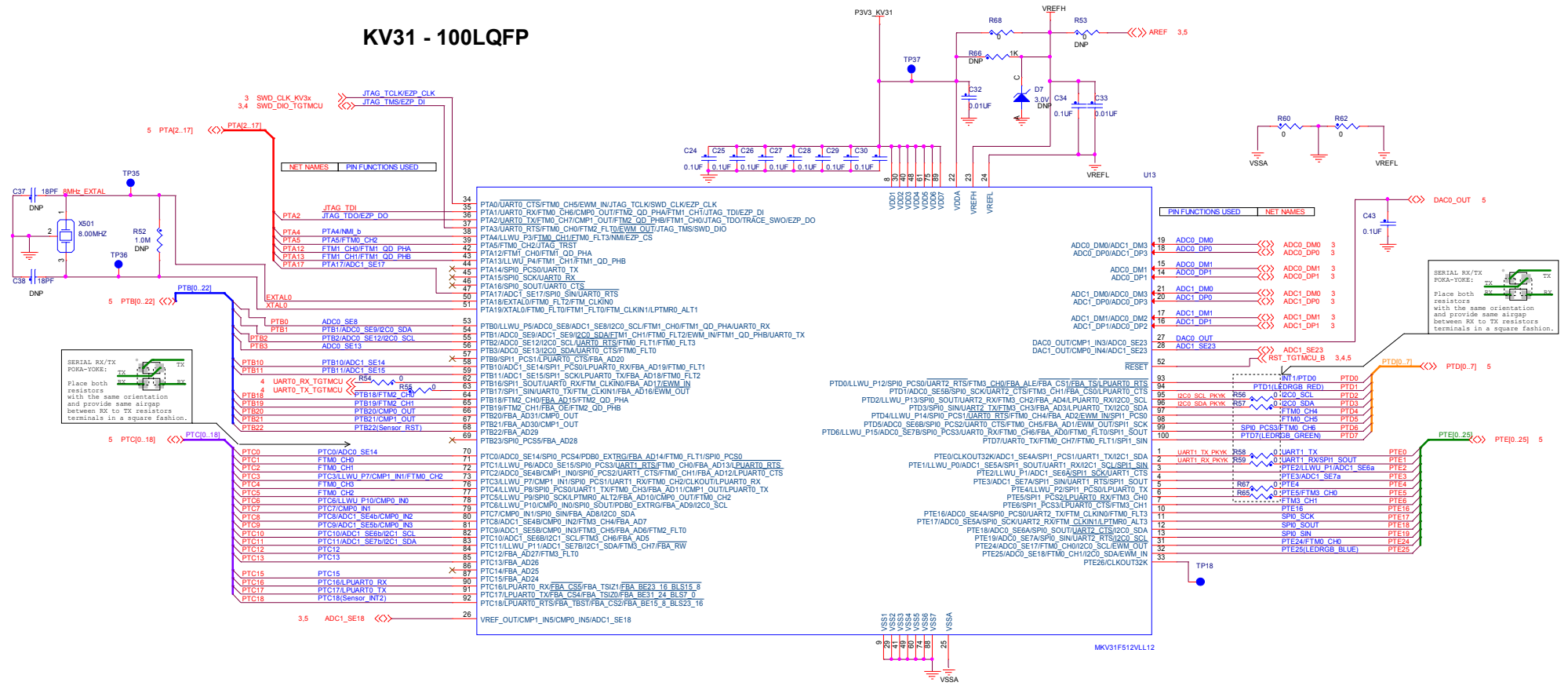

OpenSDA Interface

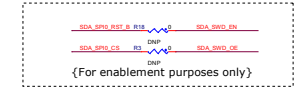
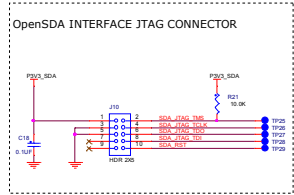
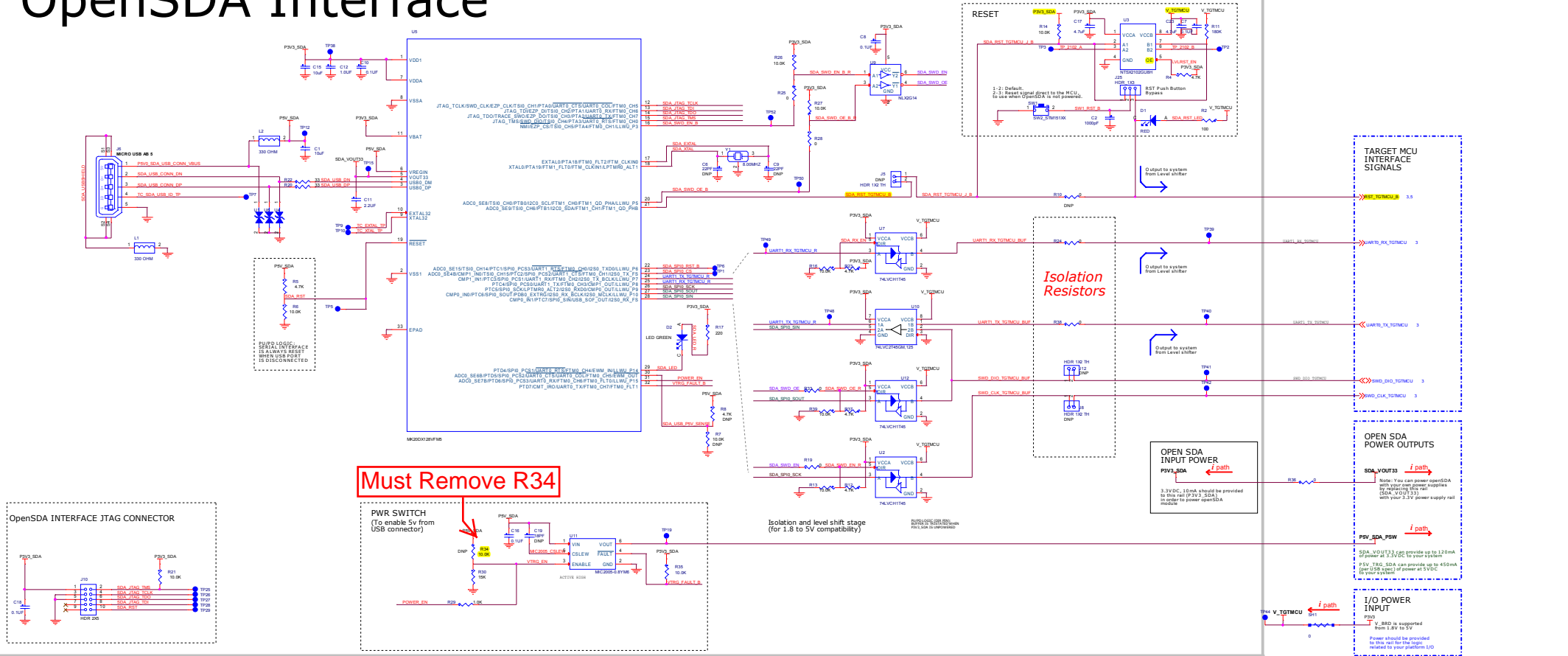

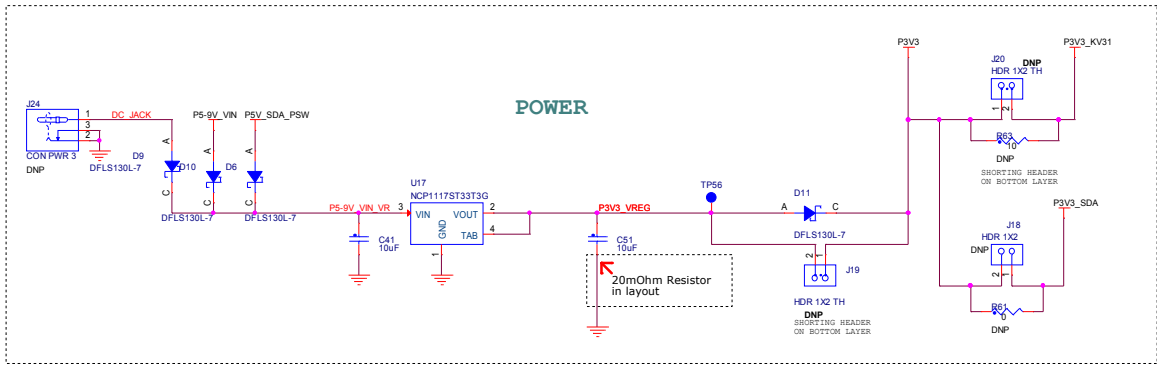

I2C INERTIAL SENSOR

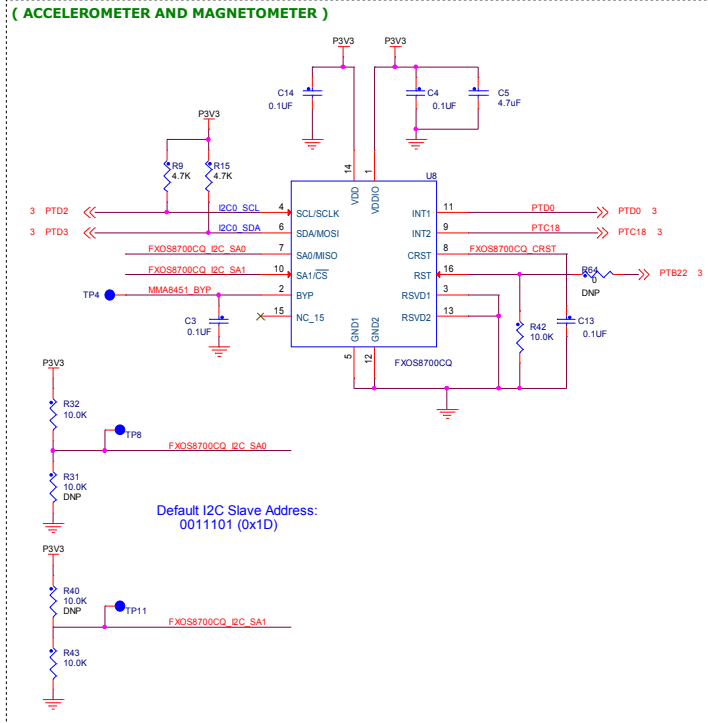

ARDUINO COMPATIBLE HEADERS

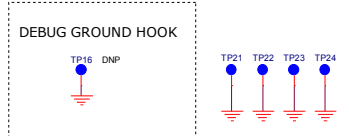
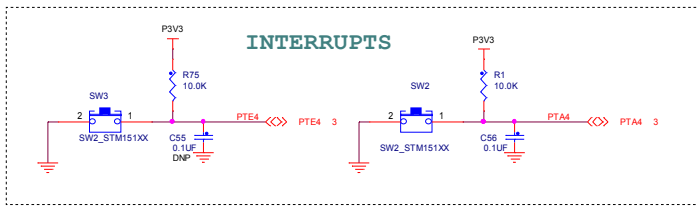
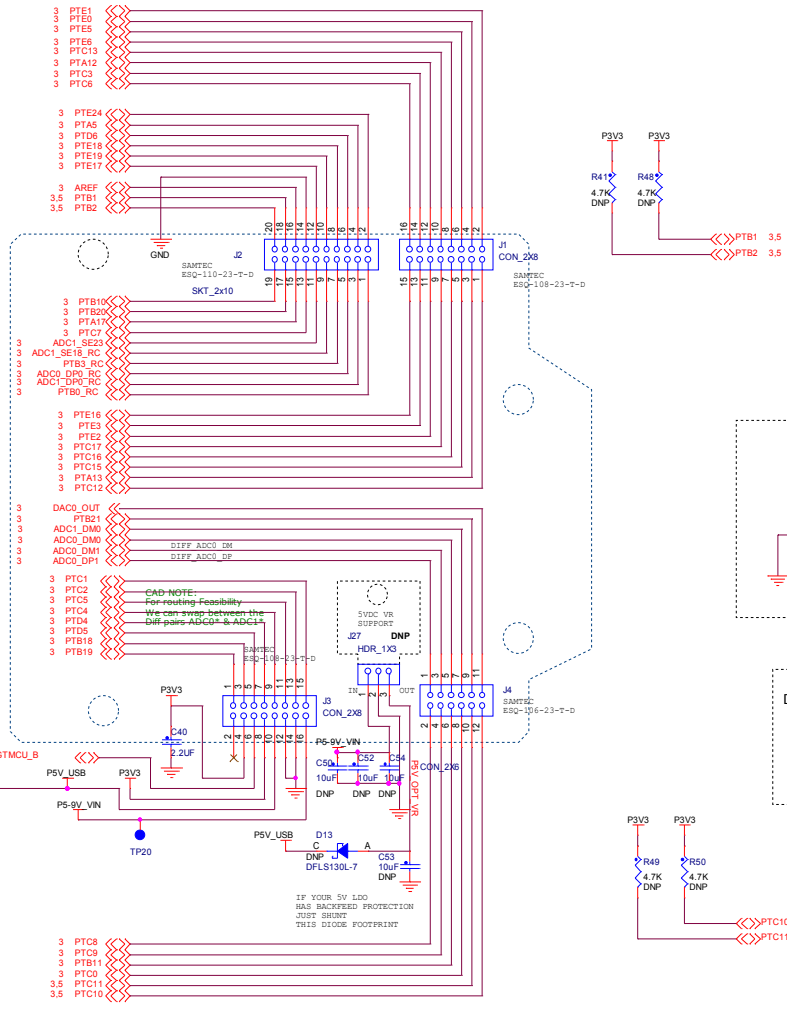

ICAP Classification: FCP: _____ FLUC: _____ PUBX: X	
Drawing Title: FRDM-KV31F	
Page Title: ARDUINO SHIELDS & COMBO SENSOR	
Size C	Document Number
Date: Tuesday, January 27, 2015	Sheet 5 of 5