

SECTION A-A SHOWN WITH TPA AND CPA (WHEN APPLICABLE) IN LATCHED POSITIONS FOR REFERENCE ONLY

SECTION A-A

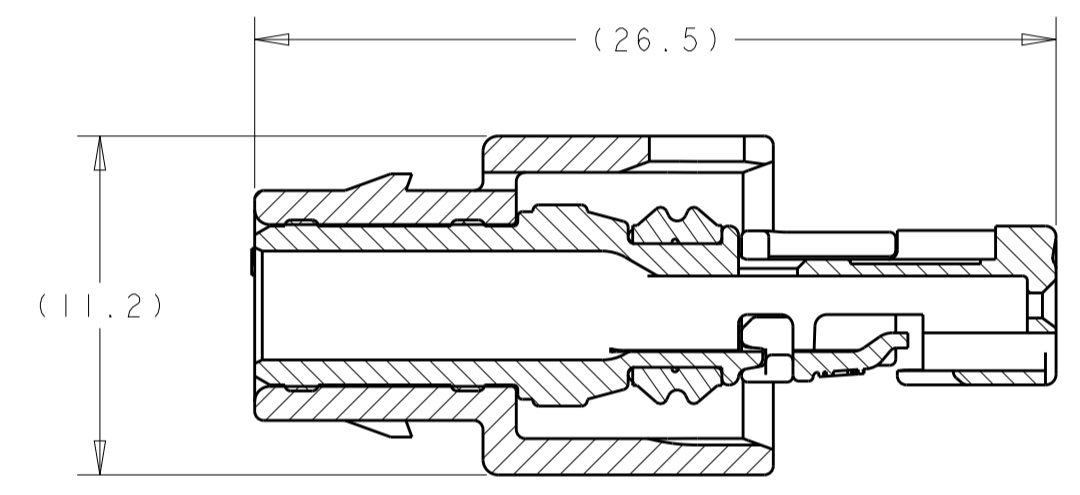

SECTION B-B

REVISIONS				
P.	LTN.	DESCRIPTION	DATE	APPV.
B1		REVISED PER ECO-13-000543	16JAN2013	DLD SLM
B2		REVISED PER ECO-14-0006392	30APR2014	DLD SLM
B3		REVISED PER ECO-15-013260	15SEP2015	DLD SLM

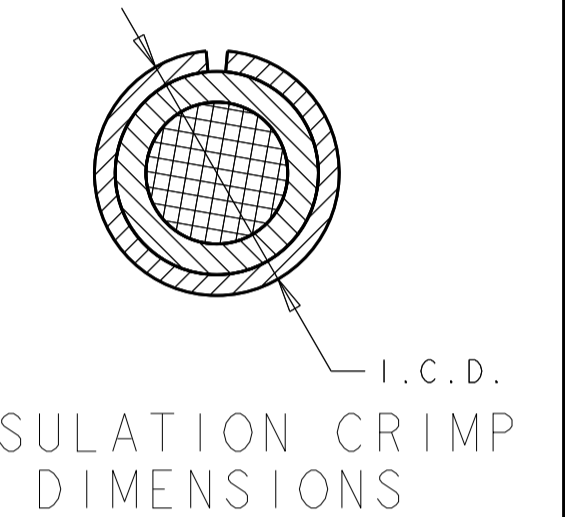
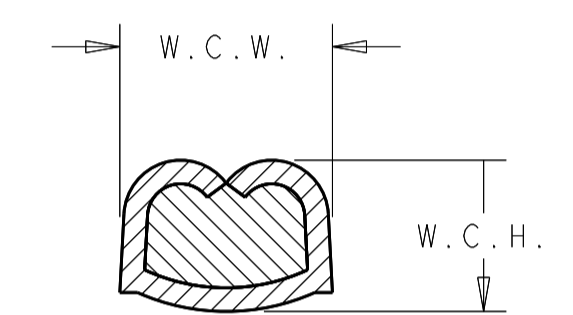
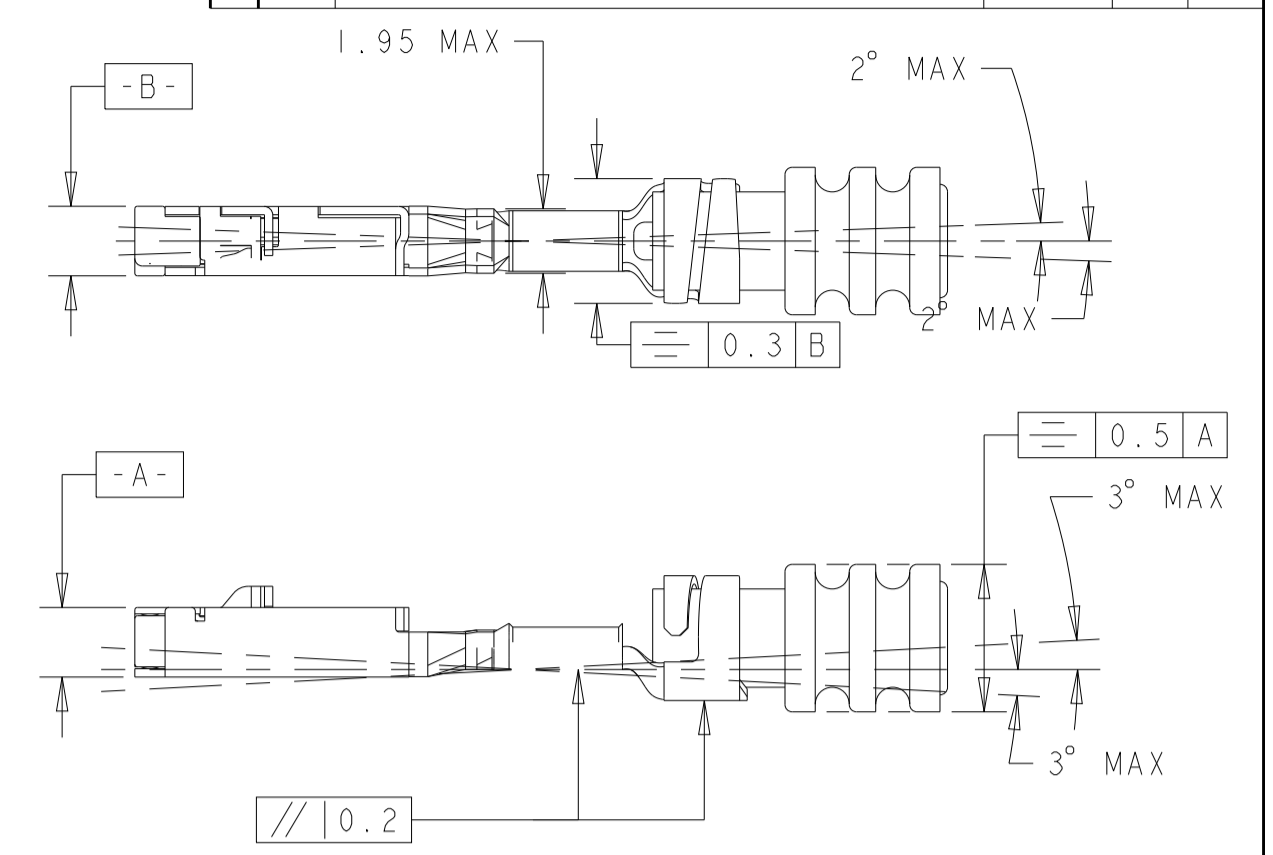

WIRE CRIMP DIMENSIONS

INSULATION CRIMP DIMENSIONS

MCON 1.2MM CLEAN BODY								
MAX TEMP	FEMALE TERMINAL PN	TERMINAL PLATING	AWG	APPLICABLE WIRE FINISHED O.D.	W.C.H.	W.C.W.	I.C.D.	WIRE SEAL PART NUMBER
125C	1670146-1	TIN	20	1.40 - 1.90mm	0.84 ±0.03	1.57 ±0.05	3.25 ±0.05	967067-1
125C	1670146-2	GOLD	20	1.40 - 1.90mm	0.84 ±0.03	1.57 ±0.05	3.25 ±0.05	967067-1
125C	1670146-3	SILVER	20	1.40 - 1.90mm	0.84 ±0.03	1.57 ±0.05	3.25 ±0.05	967067-1
125C	1418850-1	TIN	18	1.90 - 2.40mm	1.11 ±0.05	1.78 ±0.05	3.35 ±0.05	964972-1
125C	1418850-2	GOLD	18	1.90 - 2.40mm	1.11 ±0.05	1.78 ±0.05	3.35 ±0.05	964972-1
125C	1418850-3	SILVER	18	1.90 - 2.40mm	1.11 ±0.05	1.78 ±0.05	3.35 ±0.05	964972-1
125C	1418850-1	TIN	16	1.90 - 2.40mm	1.31 ±0.05	1.78 ±0.05	3.35 ±0.05	964972-1
125C	1418850-2	GOLD	16	1.90 - 2.40mm	1.31 ±0.05	1.78 ±0.05	3.35 ±0.05	964972-1
125C	1418850-3	SILVER	16	1.90 - 2.40mm	1.31 ±0.05	1.78 ±0.05	3.35 ±0.05	964972-1
150C	1670146-2	GOLD	20	1.40 - 1.90mm	0.84 ±0.03	1.57 ±0.05		2098582-1
150C	1670146-3	SILVER	20	1.40 - 1.90mm	0.84 ±0.03	1.57 ±0.05		2098582-1
150C	1418850-2	GOLD	18	1.40 - 1.90mm	1.11 ±0.05	1.78 ±0.05		2098582-1
150C	1418850-1	GOLD	16	1.40 - 1.90mm	1.31 ±0.05	1.78 ±0.05		2098582-1
150C	1418850-3	SILVER	16	1.40 - 1.90mm	1.31 ±0.05	1.78 ±0.05		2098582-1

KEYING CONFIGURATIONS

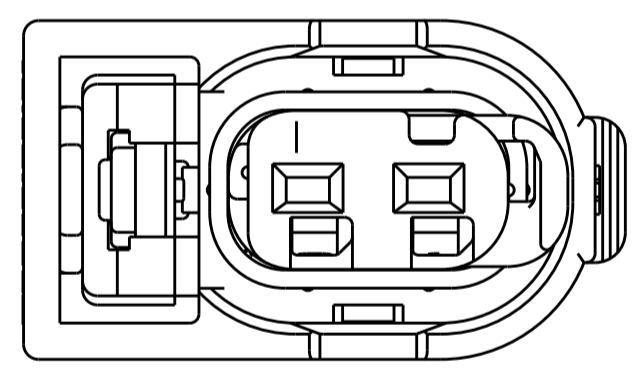

KEYING OPTION A

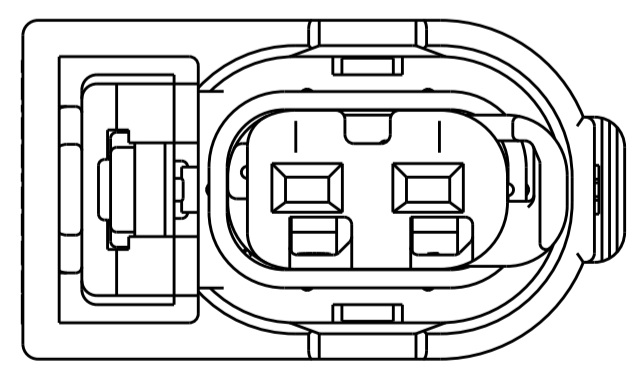

KEYING OPTION B

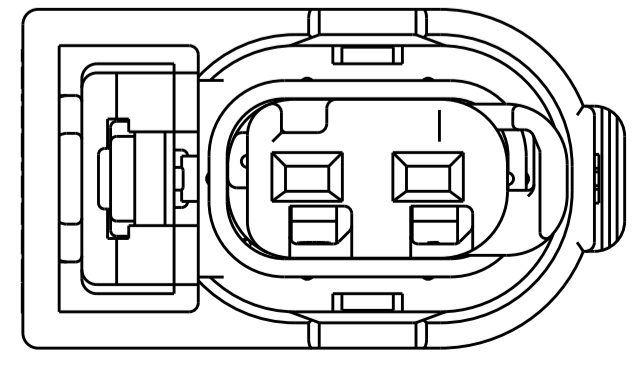

KEYING OPTION C

- PART NUMBER 2098641-6 SHOWN ON DRAWING.
- TPA AND CPA (WHEN APPLICABLE) ARE SHIPPED IN THEIR PRE-LATCHED POSITIONS. SEE INSTRUCTION SHEET 408-8968 FOR DIRECTIONS ON MOVING TPA TO THE PRE-LATCHED POSITION, IF NECESSARY.
- TERMINALS SOLD SEPARATELY. FOR USE WITH TE MCON 1.2mm CLEAN BODY CONTACT WITH WIRE SEAL. SEE AMP MCON 1.2-CB (CLEAN BODY) TABLE FOR APPLICABLE PART NUMBERS.
- APPLICABLE HEADER INTERFACE DRAWING 114-18679-1 IS AVAILABLE UPON REQUEST. A COPY OF THIS DRAWING CAN BE OBTAINED FROM THE TE CONNECTIVITY PRODUCT MANAGER, VIA YOUR TE CONNECTIVITY SALES REPRESENTATIVE OR CUSTOMER SERVICE.
- MINIMUM FEED THROUGH CONDITION WITH 1.0mm CLEARANCE ALL AROUND.
- TRACEABILITY INFORMATION PRINTED IN THIS LOCATION AT ASSEMBLY.
- NOTE LEFT BLANK INTENTIONALLY.
- INNER HOUSING ASSEMBLED 180°.
- TPA ENGAGE FORCE: PRESET TO FULL ≥ 2 N AND ≤ 60 N.
- TPA DISENGAGE FORCE: DISENGAGE FROM FULL TO PRESET ≥ 2 N AND ≤ 60 N.
- CPA ENGAGE FORCE: PRESET TO FULL WITHOUT CONNECTORS MATED ≥ 40 N.
- CPA ENGAGE FORCE: PRESET TO FULL WITH CONNECTORS MATED ≤ 30 N.
- POLARIZATION FEATURE EFFECTIVENESS: CONNECTOR MIS-MATED TURNED 180° NO MATING > 3 TIMES AVERAGE VALUE OF MATING FORCE WRONG KEYING NO MATING > 3 TIMES AVERAGE VALUE OF MATING FORCE PER USCAR-2 REVISION 5.
- VALIDATED UP TO USCAR TEMPERATURE CLASS IV.
- SEE INSTRUCTION SHEET 408-8928.
- NOTE DELETED.
- ICD IS DEPENDENT UPON WIRE INSULATION TYPE AND OD. MUST BE SUFFICIENT TO GRIP SEAL SO IT DOES NOT SLIDE OUT OF INSULATION CRIMP WHEN INSERTING INTO CONNECTOR CAVITY BUT NOT TEAR THE SEAL.
- REFERENCE SHEET 2 FOR ISOMETRIC VIEWS.

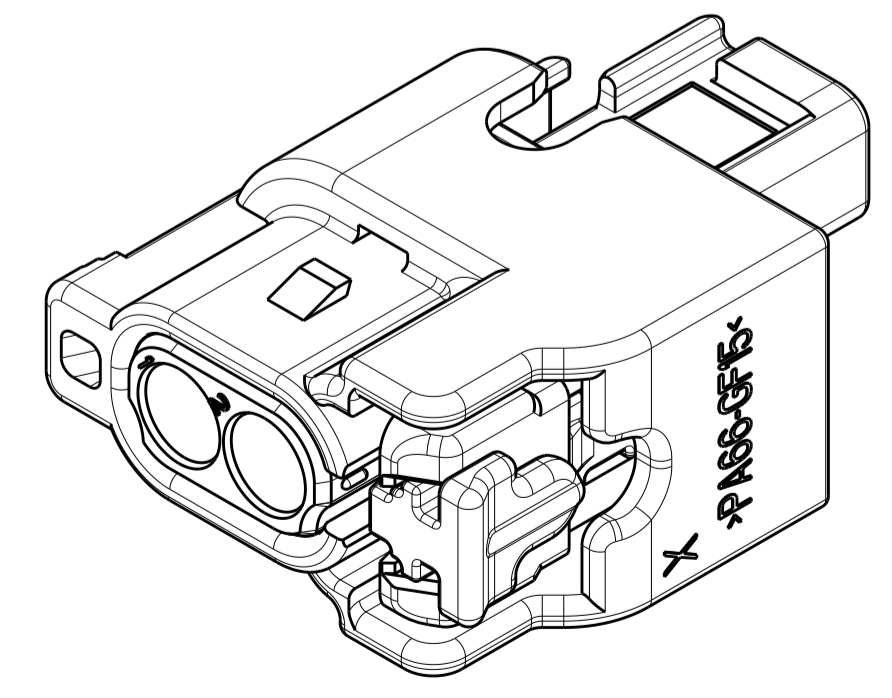
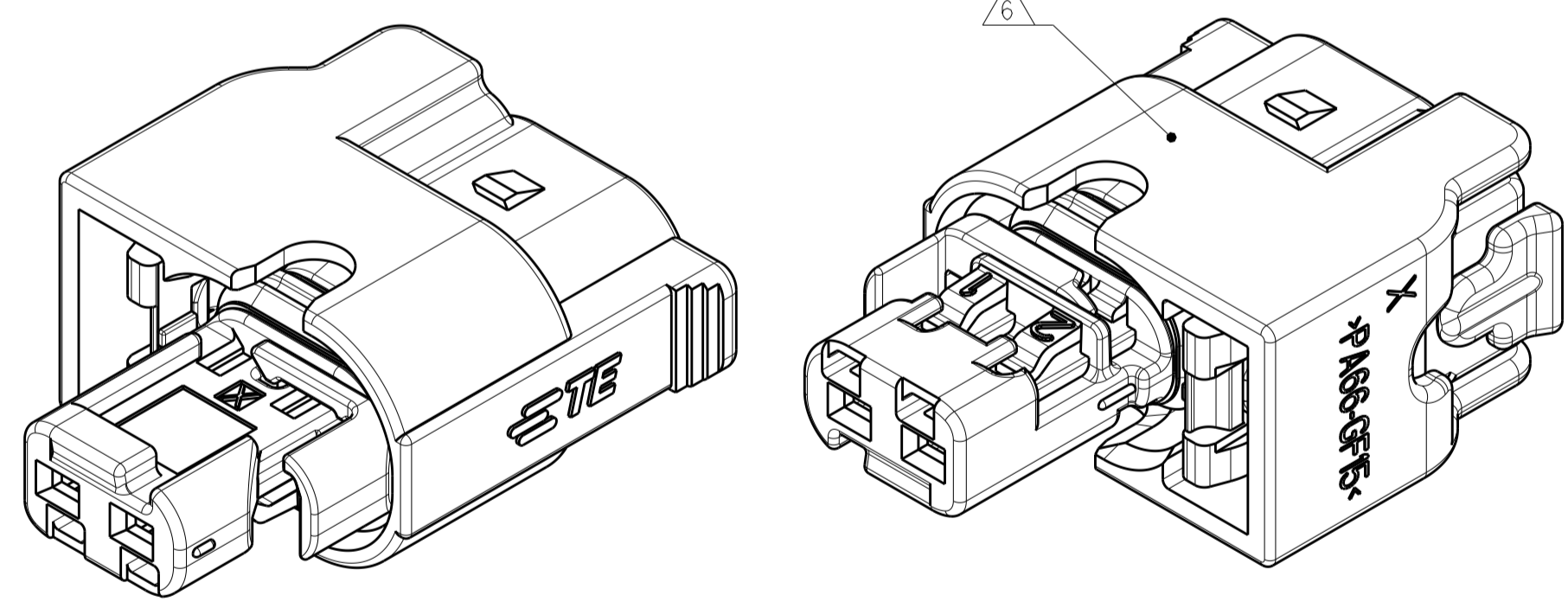

ISOMETRIC VIEWS 2098641-6

RELEASED	BROWN	2138907-1	C	4-2098641-3
RELEASED	BROWN	2138907-1	B	4-2098641-2
RELEASED	BROWN	2138907-1	A	4-2098641-1
RELEASED	BROWN	1488787-1	C	2098641-8
RELEASED	BROWN	1488787-1	B	2098641-7
RELEASED	BROWN	1488787-1	A	2098641-6
RELEASED	BROWN	1488787-1	A	2098641-5
RELEASED	BROWN	NO	A	2098641-4
RELEASED	BROWN	NO	C	2098641-3
RELEASED	BROWN	NO	B	2098641-2
RELEASED	BROWN	NO	A	2098641-1
STATUS	INNER HOUSING COLOR	CPA	KEYING CONFIGURATION	PART NUMBER

THIS DRAWING IS A CONTROLLED DOCUMENT. DIMENSIONS: mm. TOLERANCES UNLESS OTHERWISE SPECIFIED: 0 PLC ±0.3, 1 PLC ±0.3, 2 PLC ±0.10, 3 PLC ±0.1, 4 PLC ±0.1, ANGLES ±0.1. MATERIAL: SEE TABLE. FINISH: SEE TABLE. WEIGHT: 2.07g. CUSTOMER DRAWING. SCALE: 4:1. SHEET 1 OF 2. REV B3.

TE Connectivity
CONNECTOR ASSEMBLY, FEMALE, 2 POSITION SEALED, 1.2mm SIDE LATCH VERSION

100779C=2098641

REVISIONS				
P.	LTN.	DESCRIPTION	DATE	APVD.
-	-	SEE SHEET 1	-	-

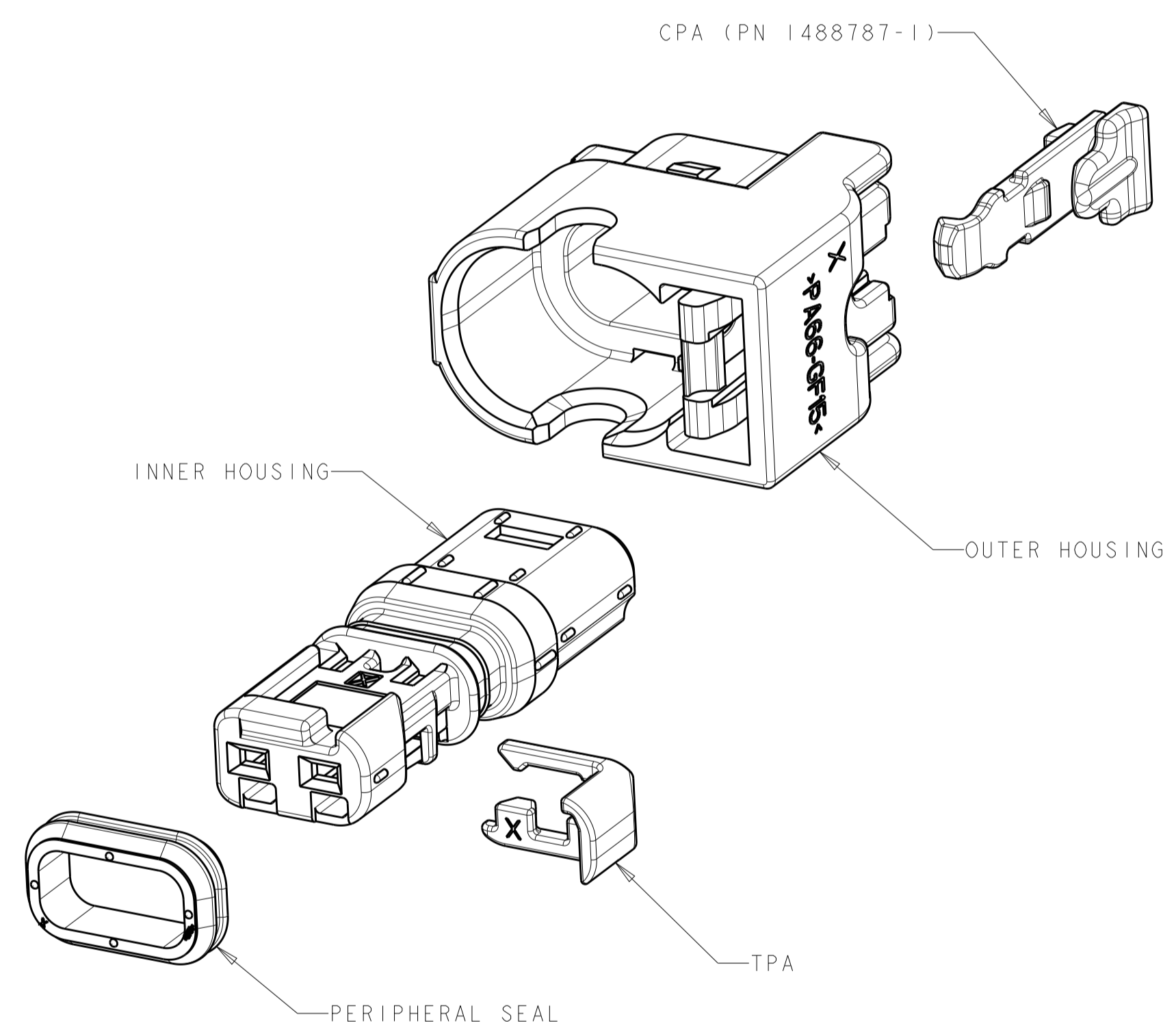
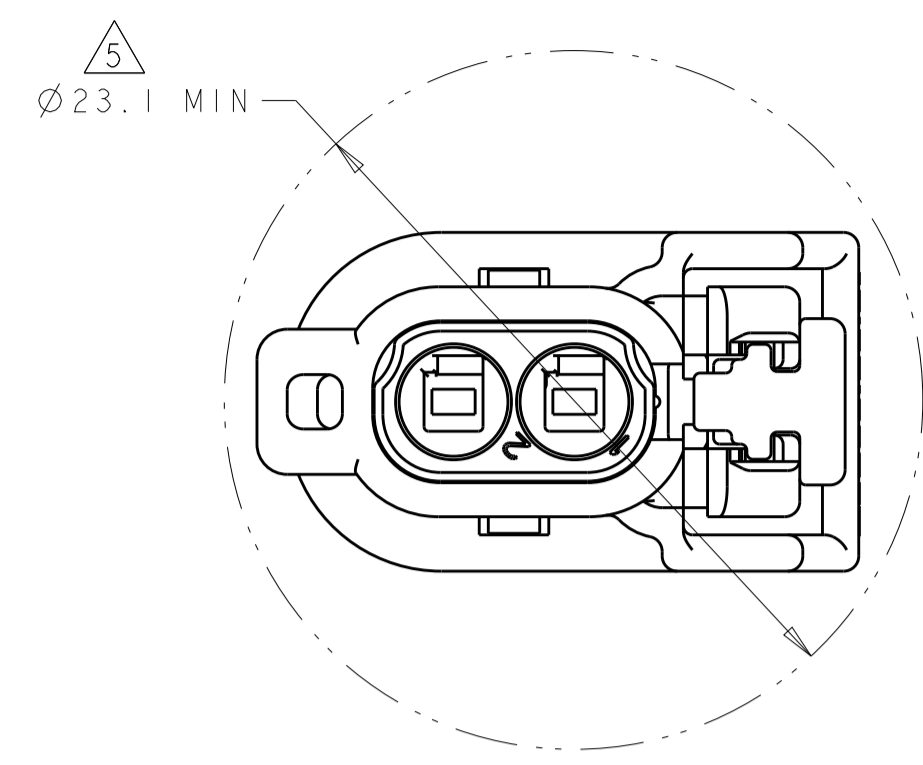

2098641-5
 EXPLODED ISOMETRIC VIEW

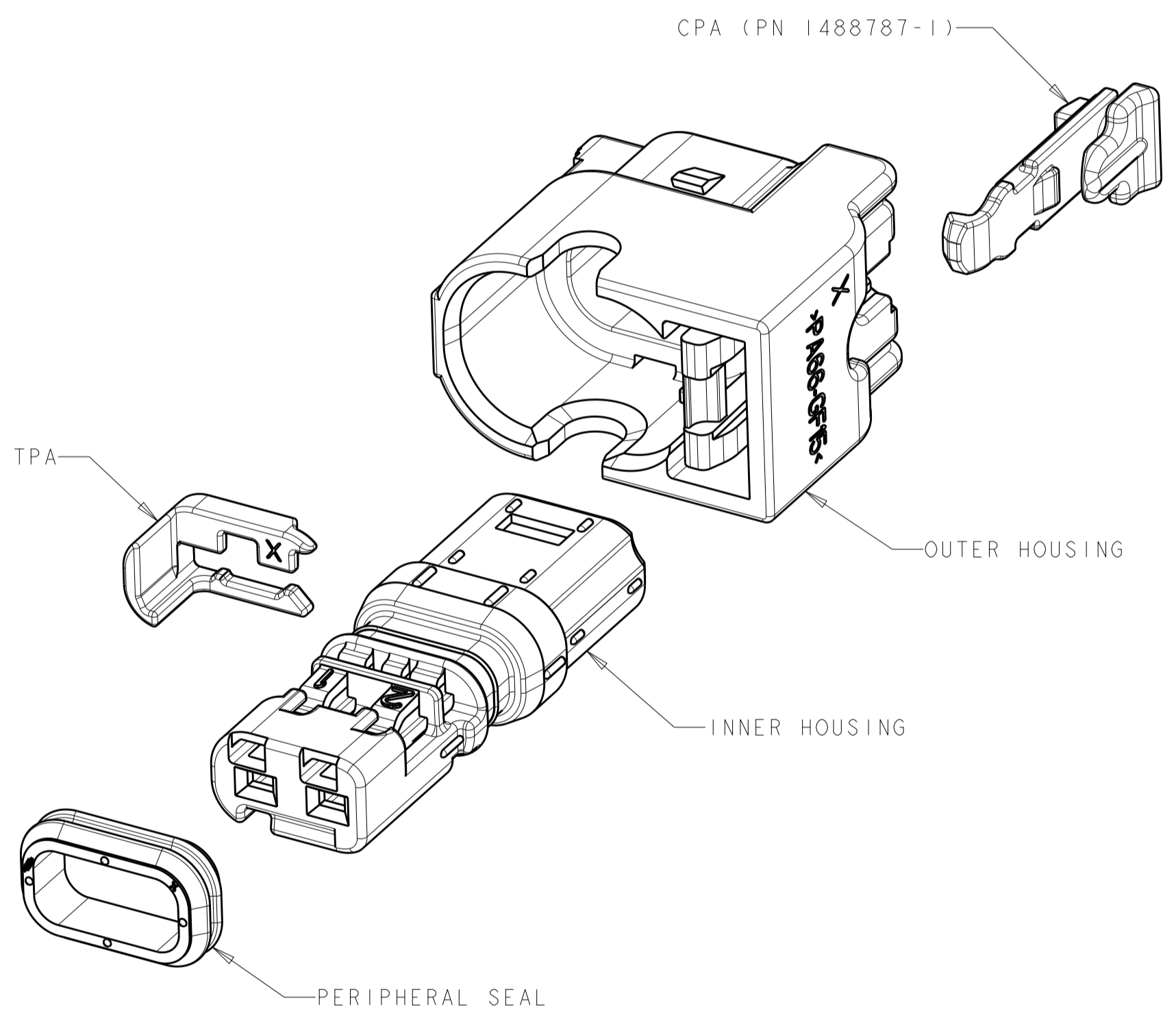
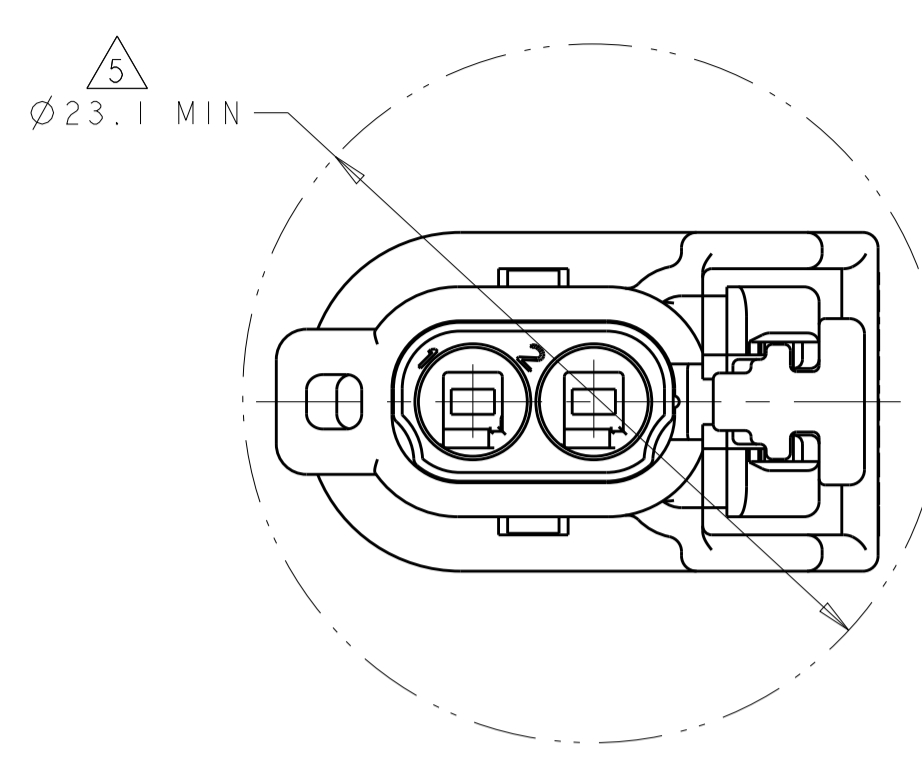

2098641-6
 EXPLODED ISOMETRIC VIEW

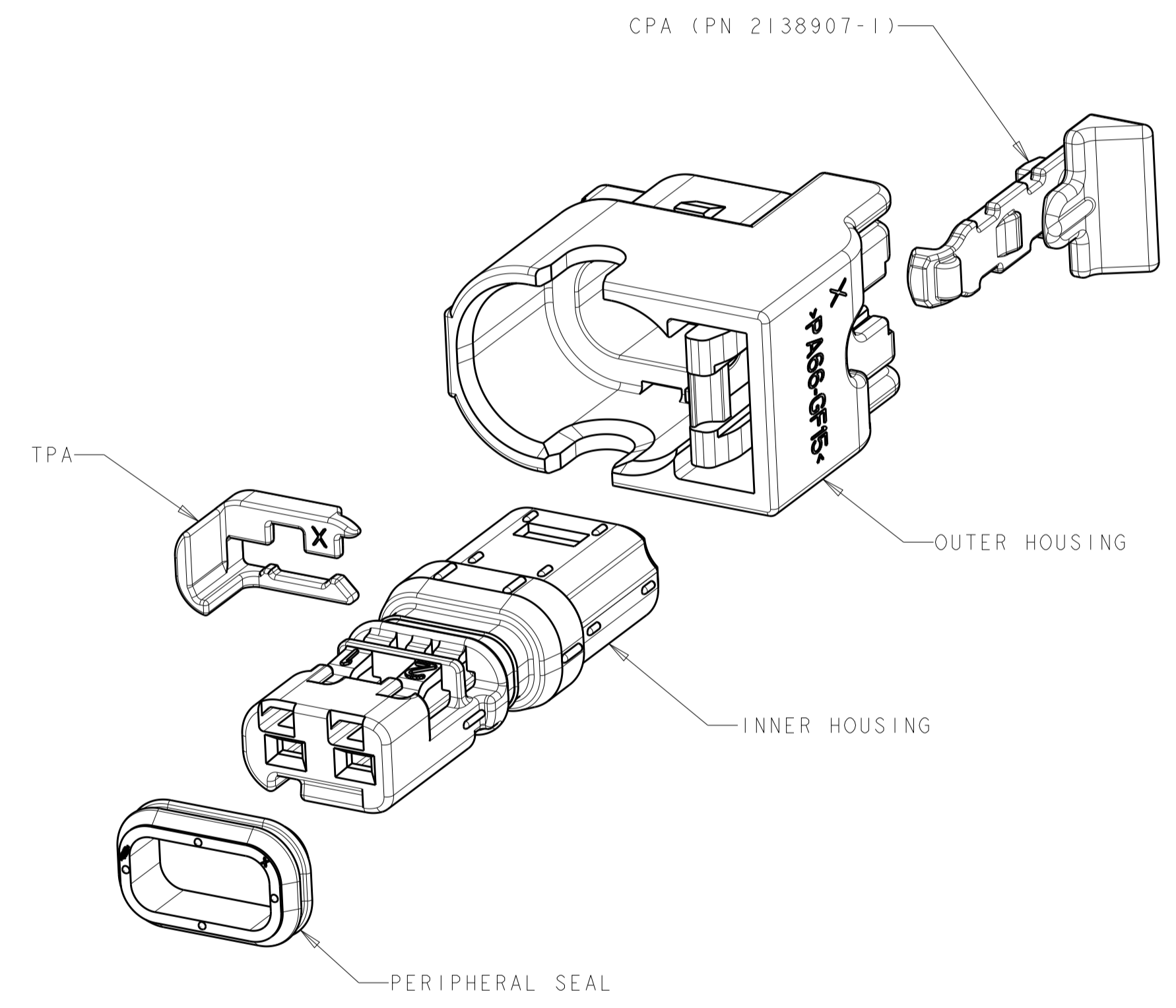
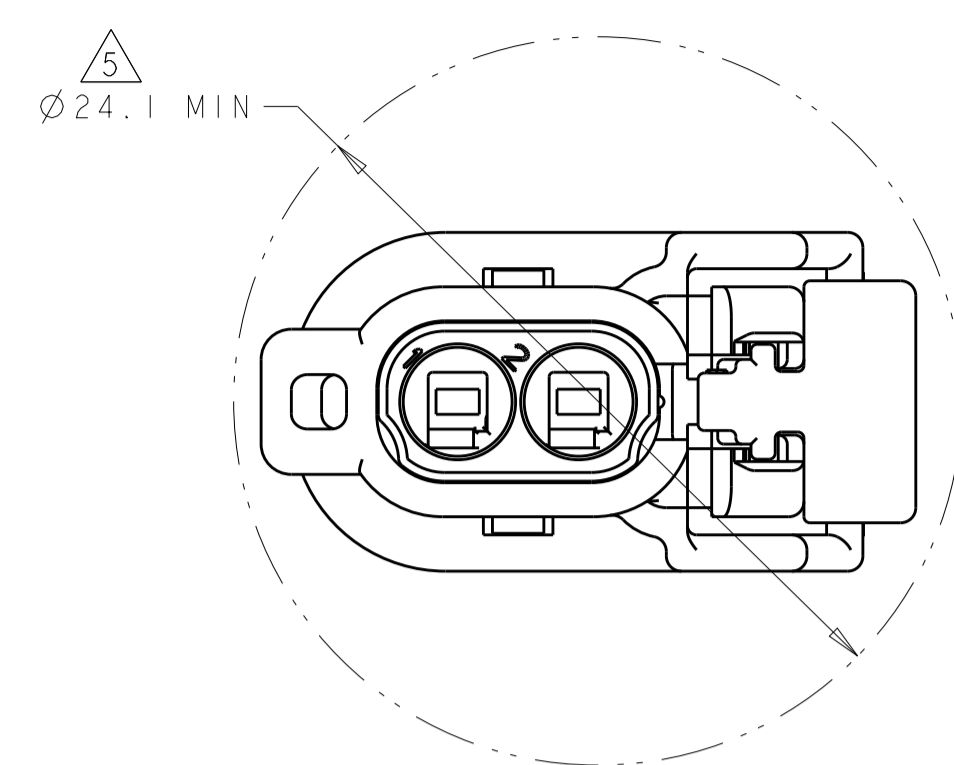

4-2098641-1
 EXPLODED ISOMETRIC VIEW

THIS DRAWING IS A CONTROLLED DOCUMENT.		DWN S. VINAY	29JAN2009		NAME CONNECTOR ASSEMBLY, FEMALE, 2 POSITION SEALED, 1.2mm SIDE LATCH VERSION
DIMENSIONS:		CHK B. BUCHTER	29JAN2009		
TOLERANCES UNLESS OTHERWISE SPECIFIED:		APVD B. BUCHTER	29JAN2009		
mm		PRODUCT SPEC	APPLICATION SPEC		
0 PLC	±	SIZE	CAGE CODE	DRAWING NO	RESTRICTED TO
1 PLC	±0.3	SCALE	4:1	SHEET	2 OF 2
2 PLC	±0.10	REV	B3	REV	B3
3 PLC	±	WEIGHT	2.07g	CUSTOMER DRAWING	
4 PLC	±	MATERIAL			
ANGLES	±	FINISH			
SEE TABLE					