

THIS DRAWING IS UNPUBLISHED.		RELEASED FOR PUBLICATION NOV ,2007.	
© COPYRIGHT 2007 By -		ALL RIGHTS RESERVED.	
PROJECT	PRJ-14-000004825		
PART NO	X-2823446-X		
HV DESC	M12, D-CODED,RAIL FEMALE 4 CRIMP		
CUSTOMER	GENERAL MARKET		

LOC	DIST	REVISIONS					
E	B	P	LTR	DESCRIPTION	DATE	DWN	APVD
		A		FIRST RELEASE	04DEC2015	GG	JS

CABLE SOCKET AS SHOWN (SEE SHEET 2 FOR CHILD PART DETAILS)

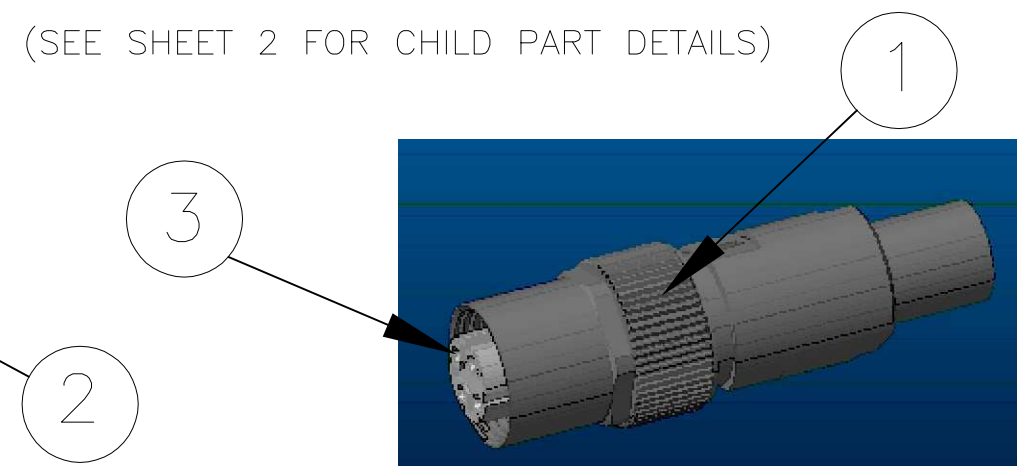
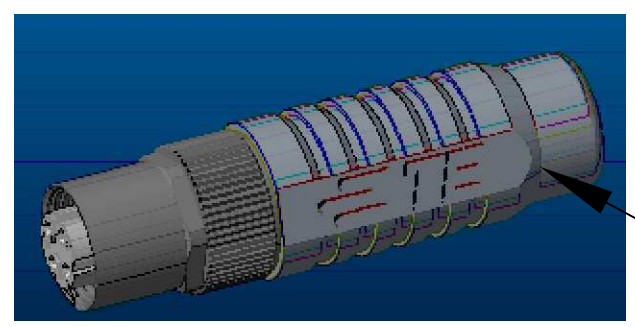
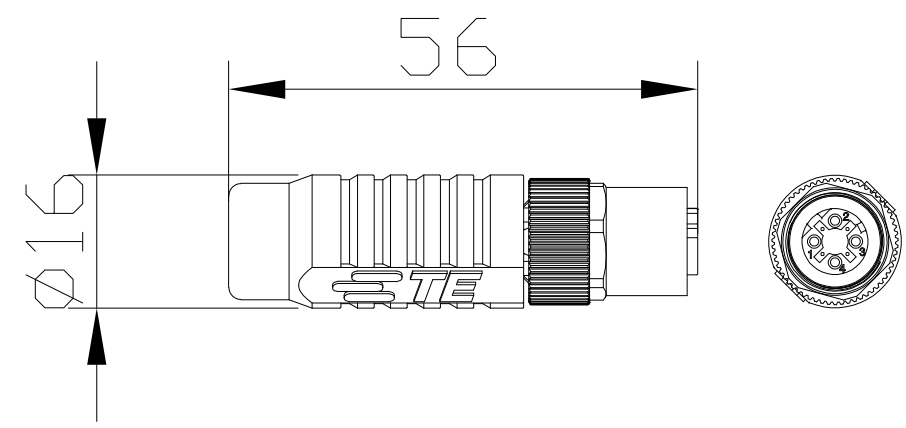

CODE	TE FG PN'S	NUMBER OF POLES IN CONNECTOR	NUMBER OF CONTACTS REQUIRED	CABLE SOCKET	BULKHEAD SOCKET	CABLE REFERENCE	AWG	TE HAND TOOL PN & TE INSERT PN	CRIMP TOOL TE PN FOR CRIMP FLANGE/SLEEVE	CRIMP INSERT TE PN'S	CABLE JACKET STRIPPING TOOL TE PN	ASSEMBLY TOOL HANDLE FOR CRIMP FLANGE TE PN	UNIVERSAL INSERT TE PN (ALL M12 CODES)	ASSEMBLY TOOL FRONT HOUSING AND BACK NUT TE PN	CABLE COLOUR	NUMBER OF WIRES PER CABLE	CABLE MANUFACTURER	CABLE PN
D code	1-2823446-1	4	4	x		Cat 5 Radox 6.6mm	AWG22	601967 & 601966	1-2823557-1	1-2823558-3	1-2823559-1	1-2823560-1	1-2823561-1	1-2823564-1	BLACK	4	H & S	12584038
D code	1-2823446-2	4	4	x		Cat 5 Radox 7.3mm	AWG22			1-2823558-4					BLACK	4	H & S	12568935
D code	1-2823446-3	4	4	x		Cat 5 Radox 8.3mm	AWG20			1-2823558-6					BLACK	4	H & S	12585489
D code	1-2823446-4	4	4	x		Cat 7 radox 8.2mm	AWG22			1-2823558-6					BLUE	8	H & S	84124806
D code	1-2823446-5	4	4	x		Cat 5 Radox 7.3mm	AWG22			1-2823558-4					BLACK	4	H & S	12568935
D code	1-2823446-6	4	4		x	Cat 5 Megaline 5.3mm	AWG26			1-2823558-1					GREY	8	Leoni	20123 3103012
D code	1-2823446-7	4	4		x	Cat 7 radox 8.2mm	AWG22			1-2823558-5					BLUE	8	H & S	84124806
D code	1-2823446-8	4	4	x		6.7mm	AWG22			1-2823558-1					BLACK	8	Belden	BE43769
D code	1-2823446-9	4	4	x		Cat 5 Radox 6.6mm	AWG22			1-2823558-2					BLACK	8	Leoni	303195

NOTES:

MATERIAL:

- ITEM NO. 1: HOUSING - BRASS, NICKEL PLATED.
- ITEM NO. 2: PLASTIC BODY - PA (UL94 V-0).
- ITEM NO. 3: CONTACT FINISH - Au (gold).
- CONTACT - CuZn (Brass).

- ALL DIMENSIONS ARE FOR NOMINAL REFERENCE ONLY.
- PACKAGING: 1 PIECE IN A BAG.
- THE CONNECTOR IS AS PER IEC 61076-2-101.
- TEMPERATURE RANGE: -40°C TO 85°C (WITH CABLE BOOT), -30°C TO 85°C (WITHOUT CABLE BOOT).
- VIBRATION & SHOCK TEST CONDUCTED AS PER IEC 61373:1999.
- FIRE PERFORMANCE CONDUCTED AS PER EN45545-2, NFF16-101 AND NFF16-102.
- THE THREAD OF THE MATING INTERLACE WITH THE COUNTERPART IS M12x1 ACCORDING TO IEC61076-2-101.
- SUPPLIER RECOMMENDED CRIMP INSERT: SHOULD BE VALIDATED ON CABLE USED.

- REFER SPEC NO 408-156003 FOR INSTRUCTION SHEET (WITH CABLE SHIELD)
- REFER SPEC NO 408-156021 FOR INSTRUCTION SHEET (WITHOUT CABLE SHIELD).
- REFER SPEC NO 408-156020 FOR INSTRUCTION SHEET (BULKHEAD CABLE).

THIS DRAWING IS A CONTROLLED DOCUMENT.		DWN	GUNA 04DEC2015		TE Connectivity			
		CHK	GANI 04DEC2015					
		APVD	JAYANTH 04DEC2015		NAME			
		PRODUCT SPEC			M12, D-CODED RAIL FEMALE 4 CRIMP CONNECTORS			
		APPLICATION SPEC			108-156001			
		MATERIAL			114-156002			
		FINISH			WEIGHT 24 g			
		CUSTOMER DRAWING			SIZE	CAGE CODE	DRAWING NO	RESTRICTED TO
					A3	00779	C-2823446	-
					SCALE	SHEET	REV	
					NTS	1 OF 2	A	

THIS DRAWING IS UNPUBLISHED. RELEASED FOR PUBLICATION NOV , 2007. ALL RIGHTS RESERVED.

LOC	DIST	REVISIONS					
E	B	P	LTR	DESCRIPTION	DATE	DWN	APVD
		-		SEE SHEET 1	-	-	-

PROJECT	PRJ-14-000004825
PART NO	X-2823446-X
HV DESC	M12, D-CODED,RAIL FEMALE,4 CRIMP
CUSTOMER	GENERAL MARKET

CABLE SOCKET AS SHOWN

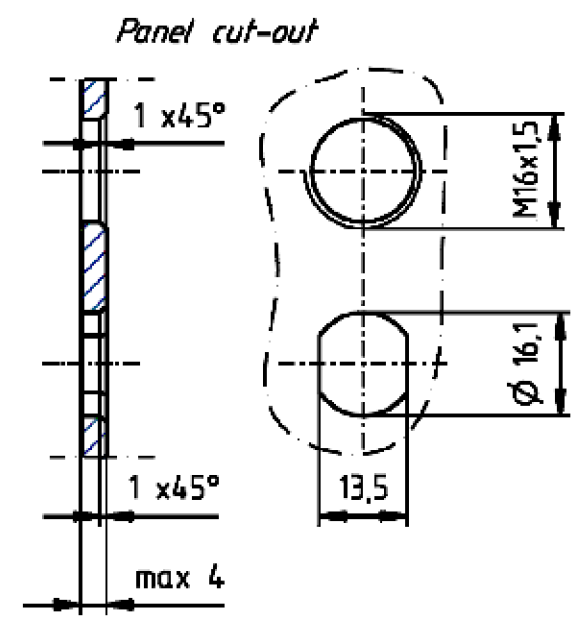
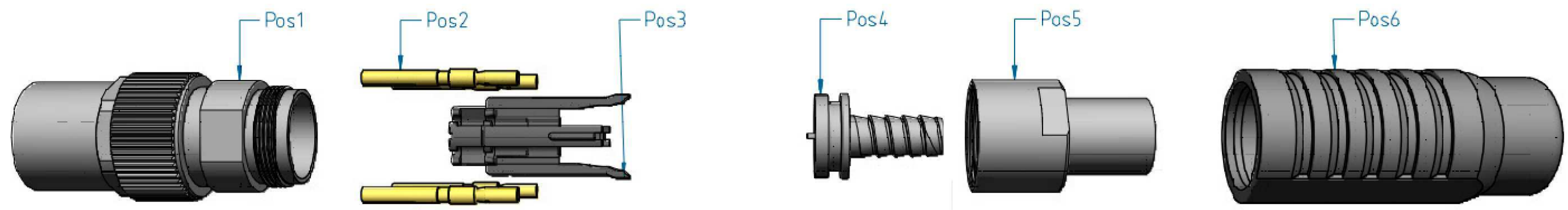

CUSTOMER CAN CHOOSE ANY ONE OF THE PANEL CUT-OUT.

BULK HEAD SOCKET TE PN'S: 1-2823446-6 & 1-2823446-7  
BULK HEAD AS SHOWN

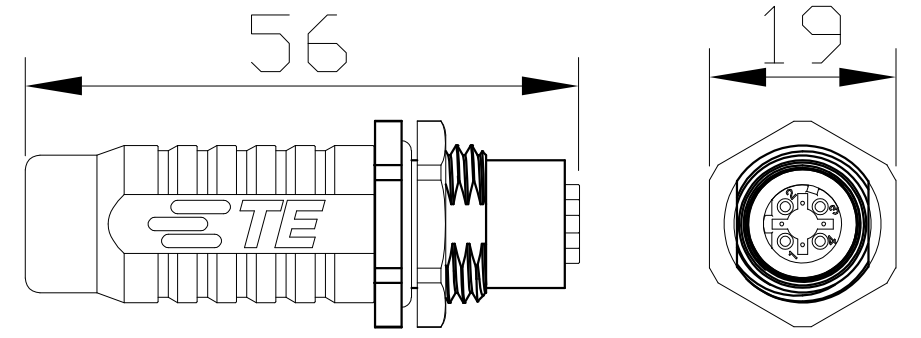
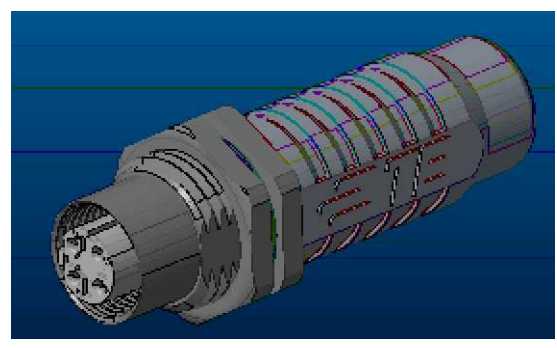

6	GRIP BOOT	1	PC
5	BACK NUT & CRIMP SLEEVE	1	PC
4	CRIMP INSERT	1	PC
3	CONTACT HOLDER	1	PC
2	CRIMP CONTACTS MACHINED	4	PC
1	FRONT HOUSING	1	PC
Position	DESCRIPTION	QTY	UNIT

THIS DRAWING IS A CONTROLLED DOCUMENT.		DWN	GUNA	04DEC2015	TE Connectivity NAME M12, D-CODED RAIL FEMALE 4 CRIMP CONNECTORS		
DIMENSIONS: MM		CHK	GANI	04DEC2015			
TOLERANCES UNLESS OTHERWISE SPECIFIED:		APVD	JAYANTH	04DEC2015			
0 PLC ± - 1 PLC ± - 2 PLC ± - 3 PLC ± - 4 PLC ± - ANGLES ± -		PRODUCT SPEC	-	-			
MATERIAL		FINISH	-	-	APPLICATION SPEC		
-		-	-	-	WEIGHT	24 g	
-		-	-	-	SIZE	A3	
-		-	-	-	CAGE CODE	00779	
-		-	-	-	DRAWING NO	C-2823446	
-		-	-	-	RESTRICTED TO	-	
-		-	-	-	CUSTOMER DRAWING	SCALE	NTS
-		-	-	-	SHEET	2 OF 2	
-		-	-	-	REV	A	