

THIS DRAWING IS UNPUBLISHED. RELEASED FOR PUBLICATION NOV ,2007.
 © COPYRIGHT 2007 By - ALL RIGHTS RESERVED.

LOC	DIST	REVISIONS					
E	B	P	LTR	DESCRIPTION	DATE	DWN	APVD
		A		FIRST RELEASE	09DEC2015	GG	JS

PROJECT	PRJ-14-000004825
PART NO	X-2823450-X
HV DESC	M12, A-CODED,RAIL FEMALE CRIMP
CUSTOMER	GENERAL MARKET

CABLE SOCKET AS SHOWN (5 POSITION)
 (SEE SHEET 2 FOR CHILD PART DETAILS)

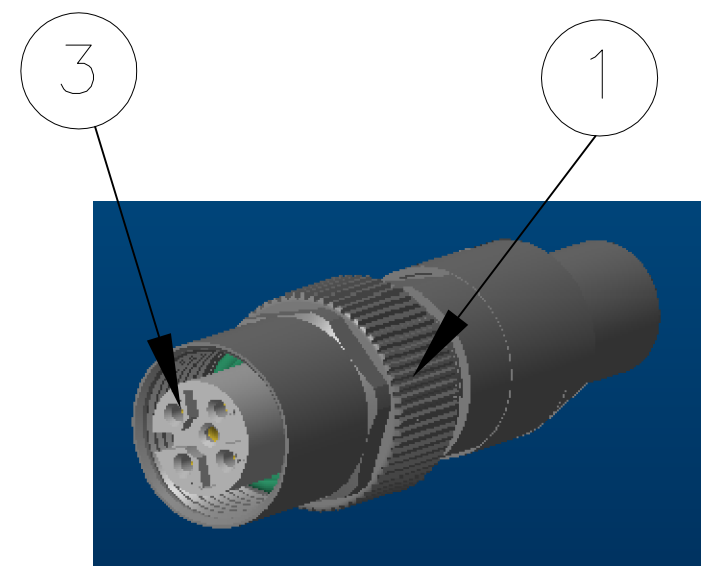
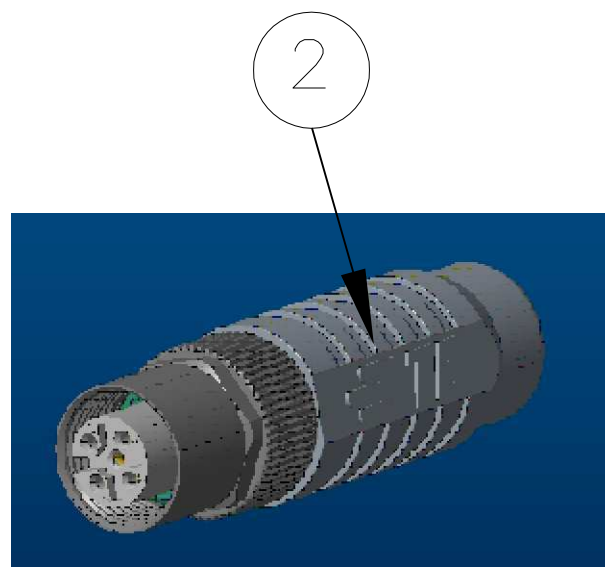
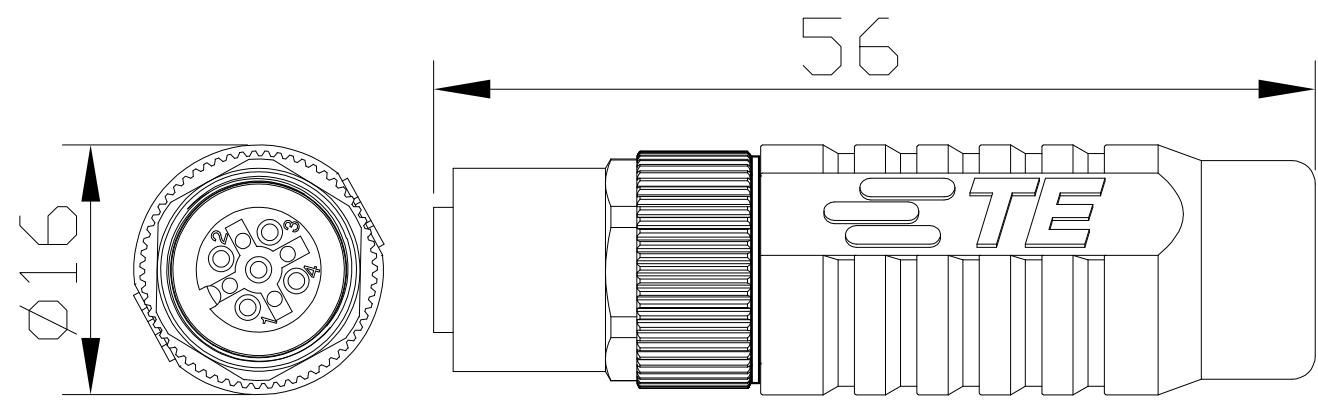

CODE	TE FG PN'S	NUMBER OF POLES IN CONNECTOR	NUMBER OF CONTACTS REQUIRED	CABLE SOCKET	CABLE REFERENCE	AWG	TE HAND TOOL PN & TE INSERT PN	CRIMP TOOL TE PN FOR CRIMP FLANGE/SLEEVE	CRIMP INSERT TE PN'S	CABLE JACKET STRIPPING TOOL TE PN	ASSEMBLY TOOL HANDLE FOR CRIMP FLANGE TE PN	UNIVERSAL INSERT TE PN (ALL M12 CODES)	ASSEMBLY TOOL FRONT HOUSING AND BACK NUT TE PN	CABLE COLOUR	NUMBER OF WIRES PER CABLE	CABLE MANUFACTURER	CABLE PN
A code	1-2823450-1	5	4	x	Cat 5 Radox 6.6mm	AWG22	601967 & 601966	1-2823557-1	1-2823558-3	1-2823559-1	1-2823560-1	1-2823561-1	1-2823564-1	BLACK	4	H & S	12584038
A code	1-2823450-2	5	4	x	Cat 5 Radox 7.3mm	AWG22			1-2823558-4					BLACK	4	H & S	12568935
A code	1-2823450-3	5	4	x	Cat 5 Radox 8.3mm	AWG20			1-2823558-6					BLACK	4	H & S	12585489
A code	1-2823450-4	8	4	x	Cat 5 Radox 7.3mm	AWG22			1-2823558-4					BLACK	4	H & S	12568935
A code	1-2823450-5	8	4	x	Cat 5 Radox 6.6mm	AWG22			1-2823558-3					BLACK	4	H & S	12584038

NOTES:

MATERIAL:
 ITEM NO. 1: HOUSING - BRASS, NICKEL PLATED.
 ITEM NO. 2: PLASTIC BODY - PA (UL94 V-0).
 ITEM NO. 3: CONTACT FINISH - Au (gold).
 CONTACT - CuZn (Brass).
 - ALL DIMENSIONS ARE FOR NOMINAL REFERENCE ONLY.
 -PACKAGING: 1 PIECE IN A BAG.
 -THE CONNECTOR IS AS PER IEC 61076-2-101.
 -TEMPERATURE RANGE: -40°C TO 85°C (WITH CABLE BOOT),
 -30°C TO 85°C (WITHOUT CABLE BOOT).
 -VIBRATION & SHOCK TEST CONDUCTED AS PER IEC 61373:1999.
 -FIRE PERFORMANCE CONDUCTED AS PER EN45545-2, NFF16-101 AND NFF16-102.
 -THE THREAD OF THE MATING INTERLACE WITH THE COUNTERPART IS M12x1 ACCORDING TO IEC61076-2-101.
 -REFER SPEC NO 408-156019 FOR INSTRUCTION SHEET (8 POSITION).
 -REFER SPEC NO 408-156022 FOR INSTRUCTION SHEET (5 POSITION).
 -CRIMP INSERT: SHOULD BE VALIDATED ON CABLE USED.
 -CUSTOMER SHOULD SELECT THE CONTACTS POSITIONS,BASED ON HIS REQUIREMENT.

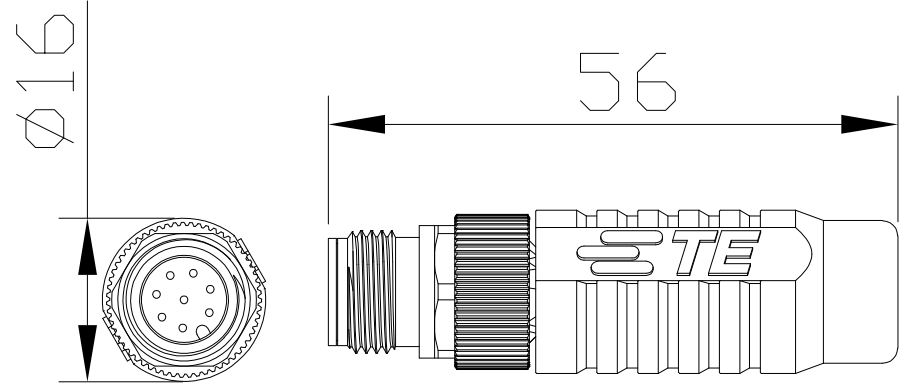

CABLE SOCKET AS SHOWN (8 POSITION) (SEE SHEET 2 FOR CHILD PART DETAILS)

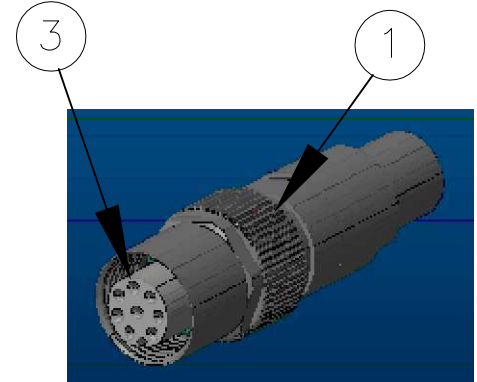
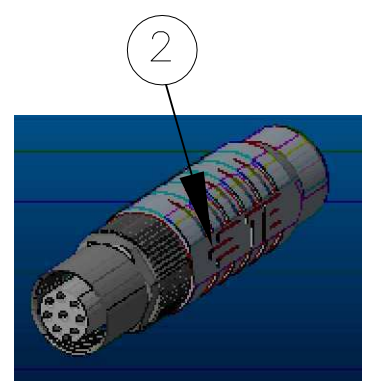

THIS DRAWING IS A CONTROLLED DOCUMENT.		DWN	GUNA	09DEC2015	TE Connectivity NAME M12, A-CODED RAIL FEMALE, CRIMP CONNECTORS					
DIMENSIONS: MM		CHK	GANI	09DEC2015						
TOLERANCES UNLESS OTHERWISE SPECIFIED:		APVD	JAYANTH	09DEC2015						
0 PLC ± - 1 PLC ± - 2 PLC ± - 3 PLC ± - 4 PLC ± - ANGLES ± - FINISH -		PRODUCT SPEC	108-156001							
MATERIAL		APPLICATION SPEC	114-156002		SIZE	CAGE CODE	DRAWING NO	RESTRICTED TO		
		WEIGHT	24 g		A3	00779	C-2823450	-		
CUSTOMER DRAWING					SCALE	NTS	SHEET	1 OF 2	REV	A

THIS DRAWING IS UNPUBLISHED.		RELEASED FOR PUBLICATION		NOV , 2007.	
© COPYRIGHT 2007 By -		ALL RIGHTS RESERVED.			
PROJECT	PRJ-14-000004825				
PART NO	X-2823450-X				
HV DESC	M12, A-CODED,RAIL FEMALE,CRIMP				
CUSTOMER	GENERAL MARKET				

LOC	DIST	REVISIONS					
E	B	P	LTR	DESCRIPTION	DATE	DWN	APVD
		-		SEE SHEET 1	-	-	-

CABLE SOCKET AS SHOWN (5 POSITION)

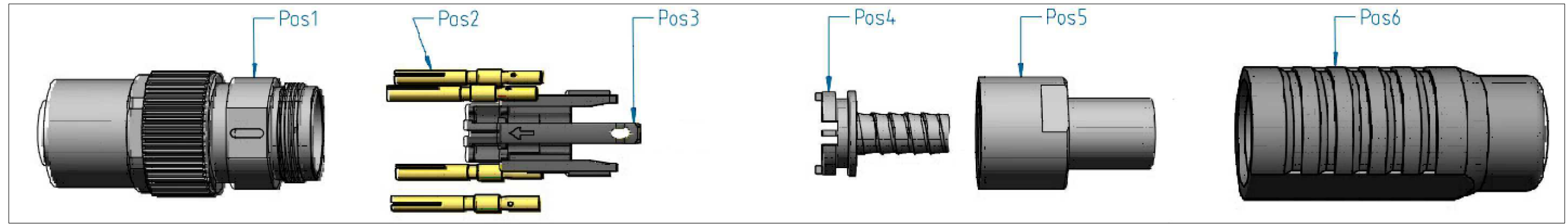

CABLE SOCKET AS SHOWN (8 POSITION)

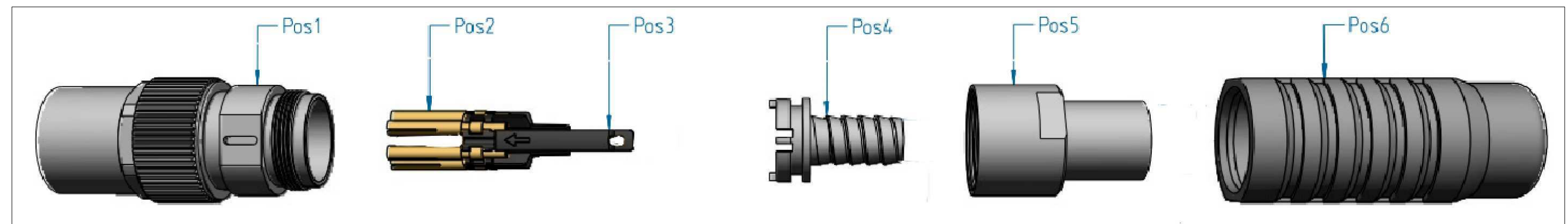

6	GRIP BOOT	1	PC
5	BACK NUT & CRIMP SLEEVE	1	PC
4	CRIMP INSERT	1	PC
3	CONTACT HOLDER	1	PC
2	CRIMP CONTACTS MACHINED	4	PC
1	FRONT HOUSING	1	PC
Position	DESCRIPTION	QTY	UNIT

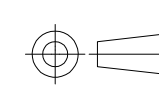
THIS DRAWING IS A CONTROLLED DOCUMENT.		DWN	GUNA	09DEC2015	 TE Connectivity	
		CHK	GANI	09DEC2015		
		APVD	JAYANTH	09DEC2015		
		PRODUCT SPEC				
DIMENSIONS: MM 		TOLERANCES UNLESS OTHERWISE SPECIFIED: 0 PLC ± - 1 PLC ± - 2 PLC ± - 3 PLC ± - 4 PLC ± - ANGLES ± -			NAME	M12, A-CODED RAIL FEMALE, CRIMP CONNECTORS
MATERIAL		FINISH			APPLICATION SPEC	
					WEIGHT	24 g
					CUSTOMER DRAWING	A300779
					DRAWING NO	C-2823450
					RESTRICTED TO	-
					SCALE	NTS
					SHEET	2 OF 2
					REV	A