

DO NOT SCALE DRAWING

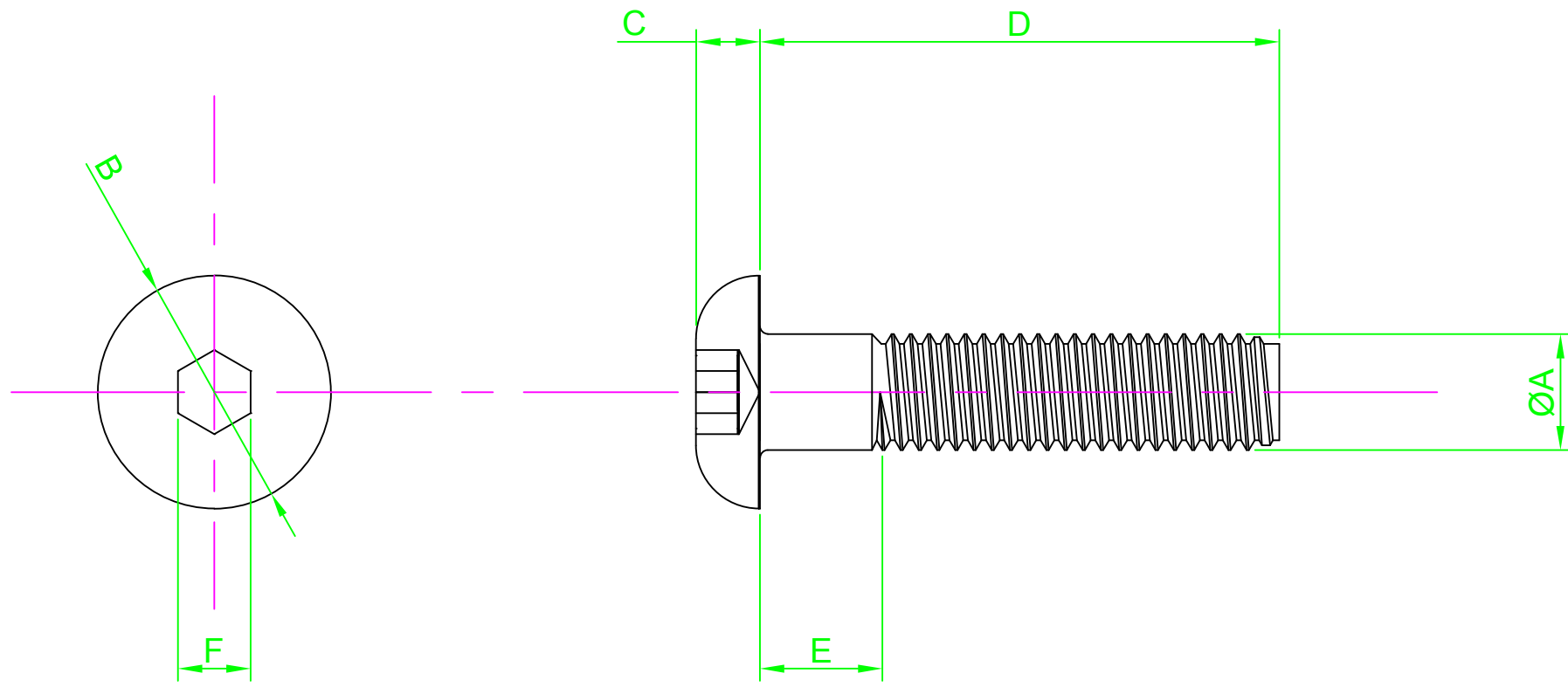

REVISION

A INITIAL DRAWING 08.01.2016

Part Number	ØA	B Max	C Max	D Length	E Max	F Ref
M3 8 BH10MC Z100	M3-0.5	5.7	1.65	8	1.5	2
M3 10 BH10MC Z100				10		
M4 8 BH10MC Z100	M4-0.7	7.6	2.2	8	2.1	2.5
M4 10 BH10MC Z100				10		
M4 16 BH10MC Z100				16		
M5 10 BH10MC Z50	M5-0.8	9.5	2.75	10	2.4	3
M5 20 BH10MC Z50				20		
M6 12 BH10MC Z50	M6-1.0	10.5	3.3	12	3.0	4
M6 20 BH10MC Z50				20		
M6 25 BH10MC Z50				25		

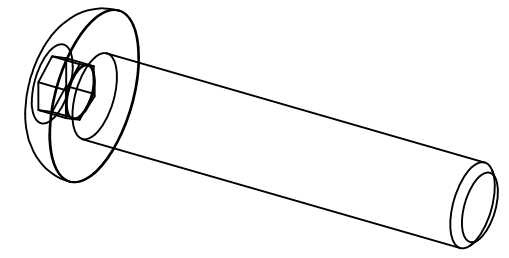

NOTES:



DESIGN RIGHT. TR FASTENINGS LTD, 2003  
 UNDER NO CIRCUMSTANCES MUST THIS  
 DRAWING BE COPIED OR DISCLOSED  
 WITHOUT FIRST OBTAINING WRITTEN  
 AUTHORITY.

UNLESS OTHERWISE SPECIFIED:  
 DIMENSIONS ARE IN MM (MILLIMETERS).  
 SURFACE FINISH:  
 TOLERANCES: ISO 7380

	NAME	DATE
DRAWN	Darryl Wilson	08.01.16
CHK'D		
APPVD		

MATERIAL:  
 Steel

HEAT TREATMENT:  
 Grade 10.9

FINISH:  
 TC1D - Commercial Zinc/Clear  
 De-Embrittled

TITLE:  
 Socket Button Head Machine Screw ISO7380

DRAWING NUMBER:  
 TR32BH10MC-ZINC

A4

