

Top View of Assembly

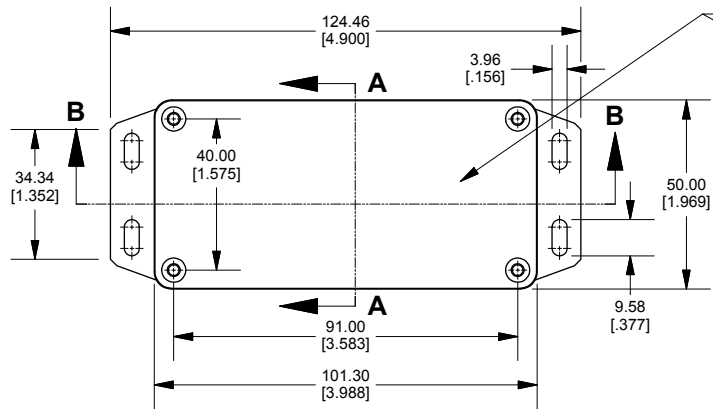

SECTION A-A End View of Assembly

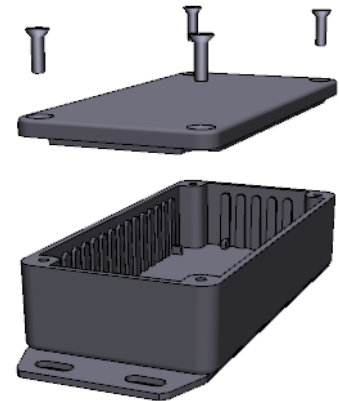
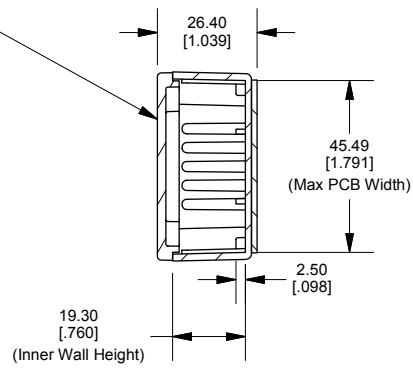

Top View Looking Inside Box

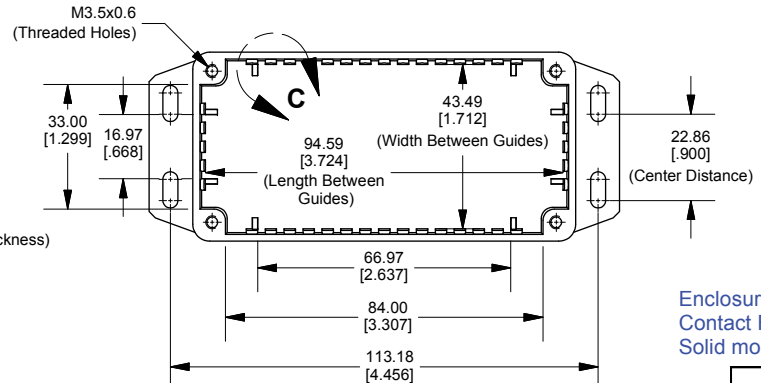

SECTION B-B Side View of Assembly

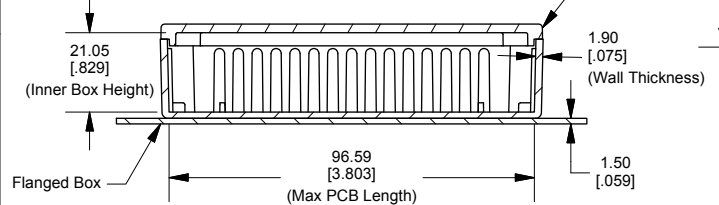

DETAIL C

Top View - Interior Features

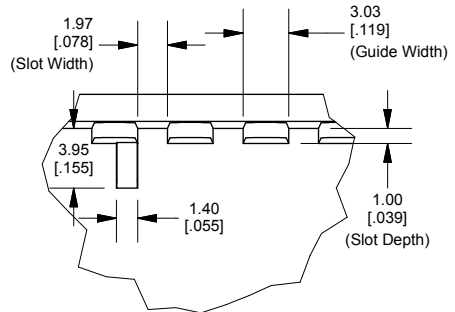

Lid

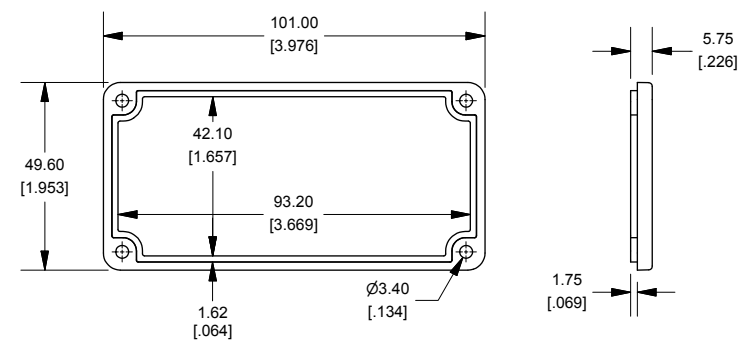

Enclosures can be Factory Modified (Milling, Drilling, Printing etc.)
 Contact Factory mjm@hammondmfg.com for quotes
 Solid models of this enclosure available in STEP or IGES.

NOTE

Purchased assembly includes box, lid and 4 cover screws.
 Box and lid are made from Diecast Aluminum Alloy.
 Bottom Flange is Welded.

PART NUMBERS

1590LF Enclosure	
Natural Finish Enclosure	1590LF
Black Textured Enclosure	1590LFBK
ACCESSORIES	
Recommended Torque: 75 ozf.in / 55 cN.m	
Plated Cover Screws (Pkg 100) [M3.5 x 12mm]	1550MS100
Black Cover Screws (Pkg 100) [M3.5 x 12mm]	1550MS100BK

1590LF
www.hammondmfg.com

Dimensions:
 mm
 [inches]