

Customer Information Sheet

DRAWING No.: H2157-XX

SHEET 2 OF 2

IF IN DOUBT - ASK

©

NOT TO SCALE

THIRD ANGLE PROJECTION

ALL DIMENSIONS IN mm

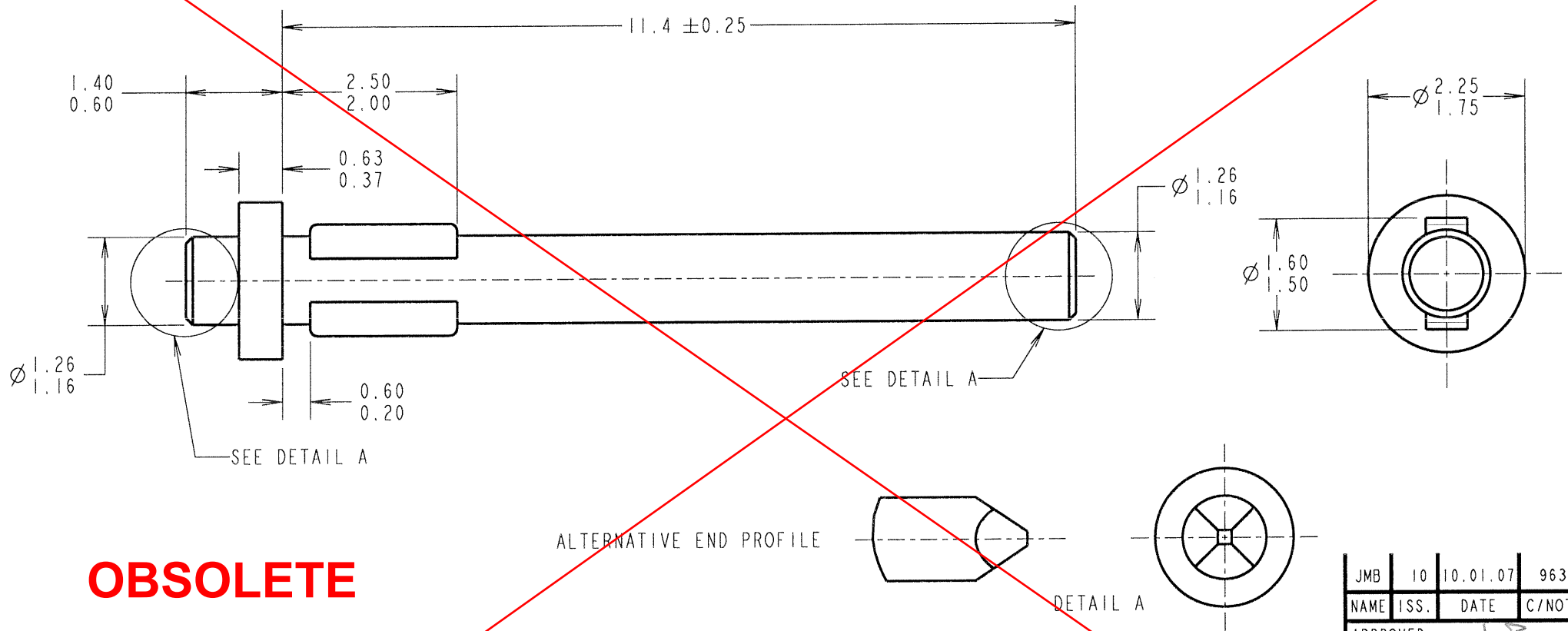

OBSOLETE

- NOTES:
1. RECOMMENDED MOUNTING HOLE SIZE = $\varnothing 1.40-1.50$ mm.
 2. RECOMMENDED PANEL THICKNESS = 1.6/2.4mm.
 3. PUNCH & DIE TOOL PART No. = Z2157-00.

PART No.	FINISH
H2157-00	UNPLATED
H2157-01	7.6 μ 100% TIN

JMB	10	10.01.07	9638
NAME	ISS.	DATE	C/NOTE
APPROVED: <i>JLB</i>			
CHECKED: <i>[Signature]</i>			
DRAWN: S. D. C			
CUSTOMER REF.:			
ASSEMBLY DRG:			

HARWIN

HARWIN INC U.S.A. TEL: (812) 542 2540 FAX: (812) 542 2541	HARWIN PLC U.K. TEL: 023 9231 4545 FAX: 023 9231 4590	HARWIN PTE SINGAPORE TEL: 65 6779 4909 FAX: 65 6779 3868
--	--	---

THIS DRAWING AND ANY INFORMATION OR DESCRIPTIVE MATTER SET OUT HEREON ARE CONFIDENTIAL AND COPYRIGHT PROPERTY OF THE HARWIN GROUP AND MUST NOT BE DISCLOSED, LOANED, COPIED OR USED FOR MANUFACTURING, TENDERING OR FOR ANY OTHER PURPOSE WITHOUT THEIR WRITTEN PERMISSION.

TOLERANCES
 X. = ± 1 mm
 X.X = ± 0.25 mm
 X.XX = ± 0.10 mm
 X.XXX = ± 0.01 mm
 ANGLES = $\pm 5^\circ$
 UNLESS STATED

MATERIAL:
 BRASS CW614N TO BS EN 12164
 (CuZn39Pb3)
 FINISH: SEE TABLE
 S/AREA: mm²

TITLE:
 TERMINAL PIN
 DRAWING NUMBER:
 H2157-XX

SHT
 2 OF 2