

TOP VIEW

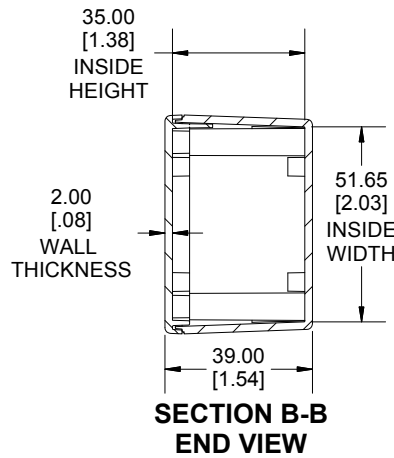

**SECTION B-B
END VIEW**

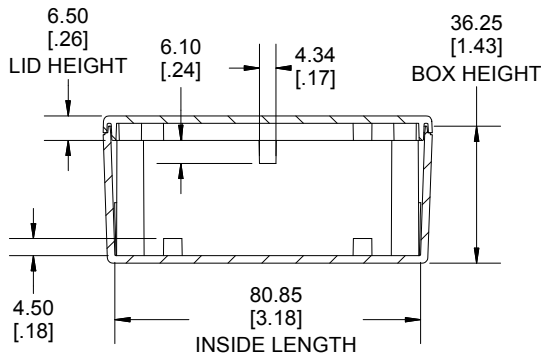

**SECTION A-A
SIDE VIEW**

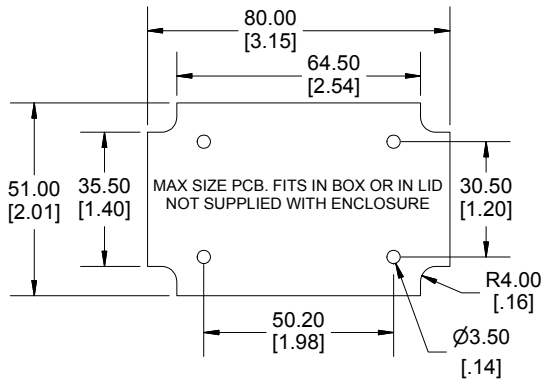

Enclosures can be Factory Modified (Milling, Drilling, Printing etc.)
 Contact Factory mjm@hammondmfg.com for quotes
 Solid models of this enclosure available in STEP or IGES.
 (Part number and text placement/orientation on our products are subject to change,
 we do not recommend using them as a locating reference for modification purposes)

NOTE	
Purchased assembly includes box, lid and	
Enclosure molded from GPABS Plastic.	
Other materials / colours available consult factory.	
Recommended Torque : (35-43) Ozf.in / (25-30) cNm	

PART NUMBERS	
1591XXLS Enclosure	
Black Textured Enclosure	1591XXLSBK
ACCESSORIES	
Black Cover Screws #4 X 1/2" Self-tapping	1591TS100BK (Pkg 100)
Plated Cover Screws #4 X 1/2" Self-tapping	1591TS100 (Pkg 100)
P.C. Board Screws	1593ATS50 (Pkg 50)
[#4 x 1/4" self-tapping (6.4mm)]	1593ATS100 (Pkg 100)

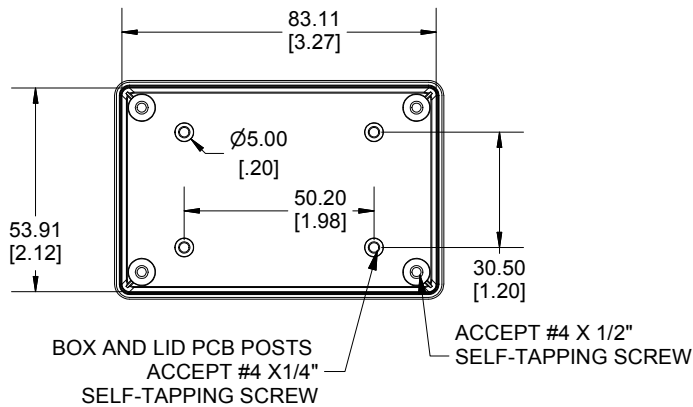

INSIDE BOX

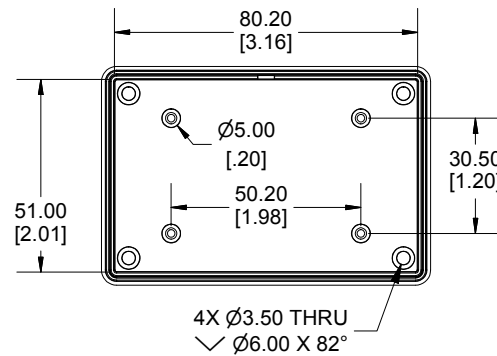

INSIDE LID

Dimensions:
 mm
 [inches]

**HAMMOND
 MANUFACTURING®**

1591XXLS

www.hammondmfg.com