

Enclosures can be Factory Modified ( Milling, Drilling, Printing etc.)  
Contact Factory [mjm@hammondmfg.com](mailto:mjm@hammondmfg.com) for quotes  
Solid models of this enclosure available in STEP or IGES.  
(Part number and text placement/orientation on our products are subject to change, we do not recommend using them as a locating reference for modification purposes)

NOTE	
Purchased assembly includes box, lid and Enclosure molded from GPABS Plastic.	
Other materials / colours available consult factory.	
Recommended Torque : (35-43) Ozf.in / (25-30) cN.m	

PART NUMBERS	
1591XXGSFL Enclosure	
Black Textured Enclosure	1591XXGSFLBK
ACCESSORIES	
Black Cover Screws #4 X 1/2" Self-tapping	1591TS100BK (Pkg 100)
Plated Cover Screws #4 X 1/2" Self-tapping	1591TS100 (Pkg 100)
P.C. Board Screws	1593ATS50 (Pkg 50)
(#4 x 1/4" self-tapping (6.4mm))	1593ATS100 (Pkg 100)

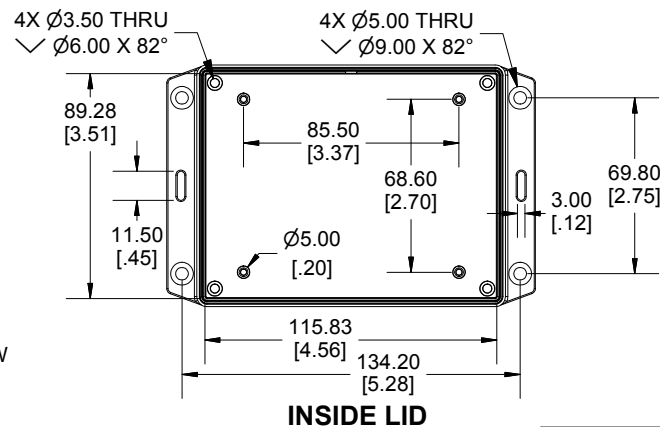
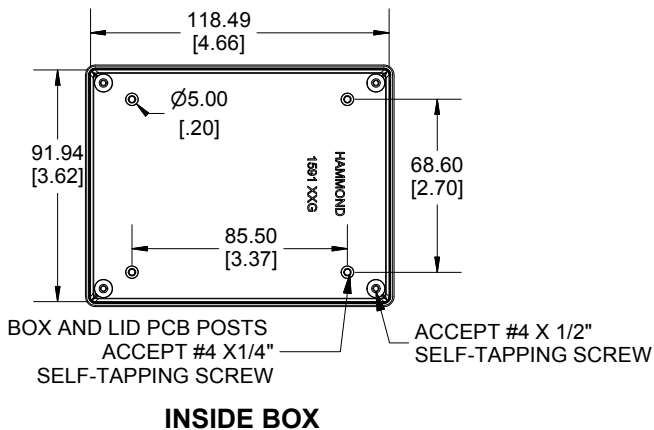

Dimensions:  
mm  
[inches]

**HAMMOND MANUFACTURING**  
**1591XXGSFL**  
[www.hammondmfg.com](http://www.hammondmfg.com)