

Product Label Detail

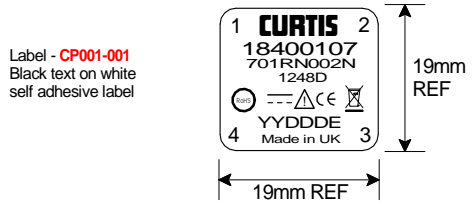

Packaging Options

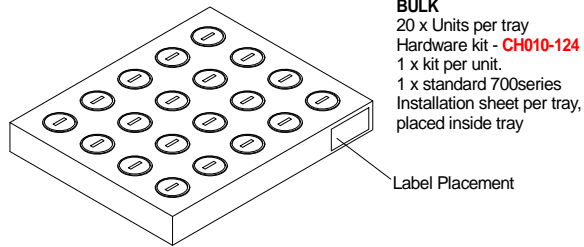

Operation Details

Module used - 17197700-110 - 701PN - 1248D
Operating Voltage - 12-48VDC
Absolute - 9-60VDC

Tray or Box Label Detail

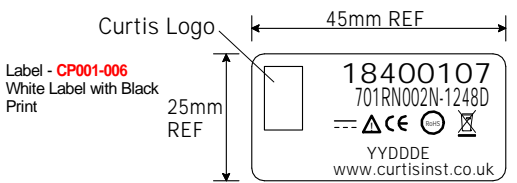

SINGLE PACK OPTION

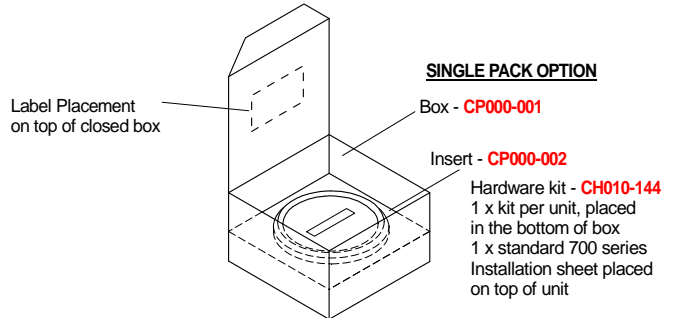

HOURMETER

PIN 1 - Positive
PIN 2 - Negative
PIN 3 - Input
PIN 4 - N/C

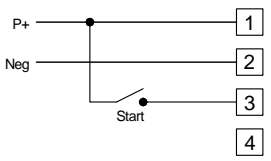

ISSUE STATUS:		DRAWN BY	CHECK BY	APP'D BY	DATE:	MATERIAL:	Curtis Instruments (UK) Ltd.	
ISSUE: A	C/NOTE No: Release	PD	DP		22nd April 2010	As stated		
ISSUE:	C/NOTE No:	>>>>>> DO NOT SCALE <<<<<<<<			TOLERANCE:	N/A	Title: Outline and Dimension for: 701RN002N-1248D Standard Bezel	
ISSUE:	C/NOTE No:	DIMENSIONS		IMPERIAL	METRIC	PC No:		
ISSUE:	C/NOTE No:	5, Upper Priory Street, NORTHAMPTON NN1 2PT Tele: (01604) 629755. Fax: (01604) 629876.					Drg. No:	UK0408 - (18400107)