

Part number	no. of contacts	A	B	C	D	E	F	G	H
1512006x401xxx	6	2,54	6,96	8,89	5,76	4,76	6,56	1,05	8,06
1512012x401xxx	12	6,35	10,77	12,70	9,57	8,57	10,37	2,96	11,87
1512016x401xxx	16	8,89	13,31	15,24	12,11	11,11	12,91	4,23	14,41
1512020x401xxx	20	11,43	15,85	17,78	14,65	13,65	15,45	5,50	16,95
1512026x401xxx	26	15,24	19,66	21,59	18,46	17,46	19,26	7,40	20,76
1512032x401xxx	32	19,05	23,47	25,40	22,27	21,27	23,07	9,31	24,57
1512040x401xxx	40	24,13	28,55	30,48	27,35	26,35	28,15	11,85	29,65
1512050x401xxx	50	30,48	34,90	36,83	33,70	32,70	34,50	15,02	36,00
1512068x401xxx	68	41,91	46,33	48,26	45,13	44,13	45,93	20,74	47,43
1512080x401xxx	80	49,53	53,95	55,88	52,75	51,75	53,55	24,55	55,14
1512100x401xxx	100	62,23	66,65	68,58	65,45	64,45	66,25	30,90	67,75

Packaging	
000	tape & reel with 220pcs per reel
333	samples

performance level	
2	PL1:>500 mating cycles
6	PL2:>250 mating cycles
5	min 0,06µm Au over 0,7+0,2µm PdNi

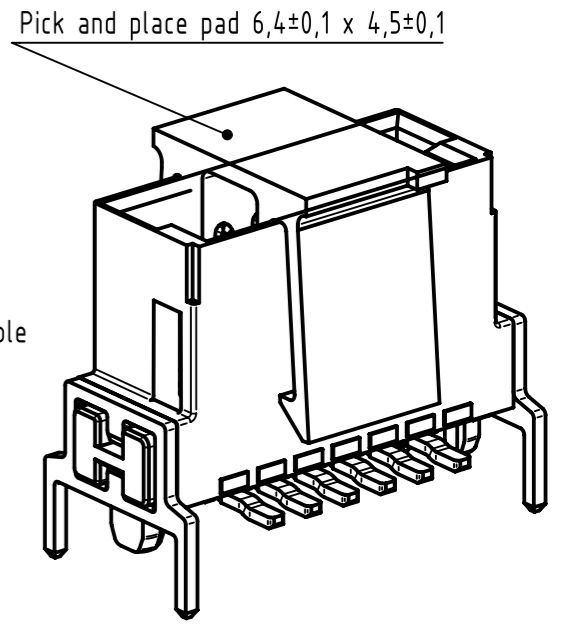

Find further technical information on the drawing DS 15111100200

	All Dimensions in mm Original Size DIN A3	Scale 5:1	Free size tol.	Ref.
	All rights reserved Department EC PD - CN	Created by ZHUANGJ	Inspected by LUOK	Standardisation HOFFMANN
HARTING Electronics GmbH D-32339 Espelkamp	Title har-flex THR straight male 3,25mm			Date 2016-06-28
	Type TB	Number 1512XXXX401XXX		State Final Release
				Doc-Key / ECM-Nr. 100632974/UGD/000/C 500000105957
				Rev. C
				Page 1/1