

DESIGNED & DIMENSIONED  
IN MILLIMETERS [INCHES]

S2M-1XX-XX-X-D-XX-XX

DO NOT  
SCALE FROM  
THIS PRINT

No OF POSITIONS  
\*\*02,\*\*-04, -05, -07, -10, -15, -20, -25, & -30 (PER ROW) AVAILABLE AS STANDARD; OTHER SIZES BETWEEN -05 THRU -50 AVAILABLE AS ASO

LEAD STYLE  
-01: THROUGH HOLE (USE C-56-01-X)  
-02: SURFACE MOUNT (USE C-56-05-X) (31-50 POSITION, NOT RELEASED)

PLATING SPECIFICATION  
-F: FLASH GOLD SELECTIVE (USE C-56-XX-F)  
-S: SELECTIVE GOLD (USE C-56-XX-S)  
-L: LIGHT SELECTIVE (USE C-56-XX-L)

PACKAGING  
-TR: TAPE & REEL (-02 LEAD ONLY)

OPTION  
-K: POLYIMIDE FILM PAD (USE K-DOT-217-.313-.005) (-02 LEAD ONLY)  
-LC: LOCKING CLIP (-02 LEAD STYLE ONLY) (USE LC-07-TM)  
-DS: DUAL SCREW DOWN FOR .062 BOARD (SEE FIG 4 & 5 SHT 3) (NOT AVAILABLE WITH -LC OPTION) (ONLY AVAILABLE 2-30 POSITIONS) (USES S2M-XX-D-DS, CPS-RR-XX-XX-X, ACCRT-01 AND WT-27-02-T ALWAYS FILLED)

ROW SPECIFICATION  
-D: DOUBLE ROW

(\* = MUST CHOOSE -02 LEAD AND -TR PACKAGING)

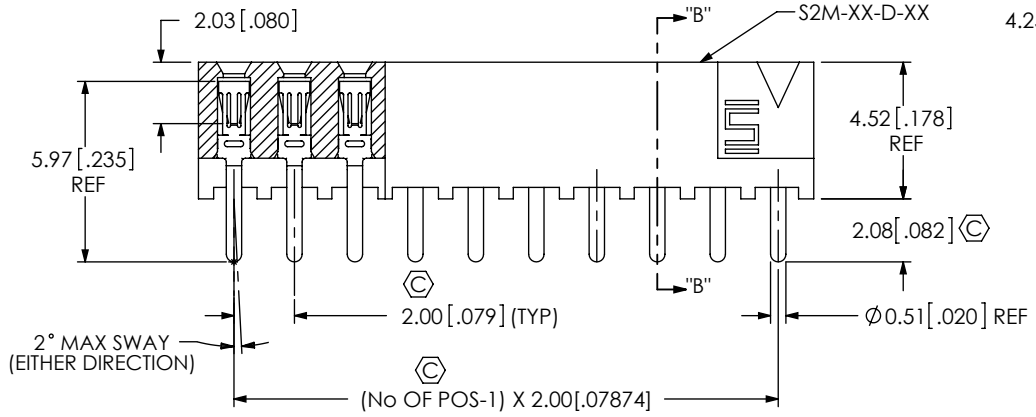
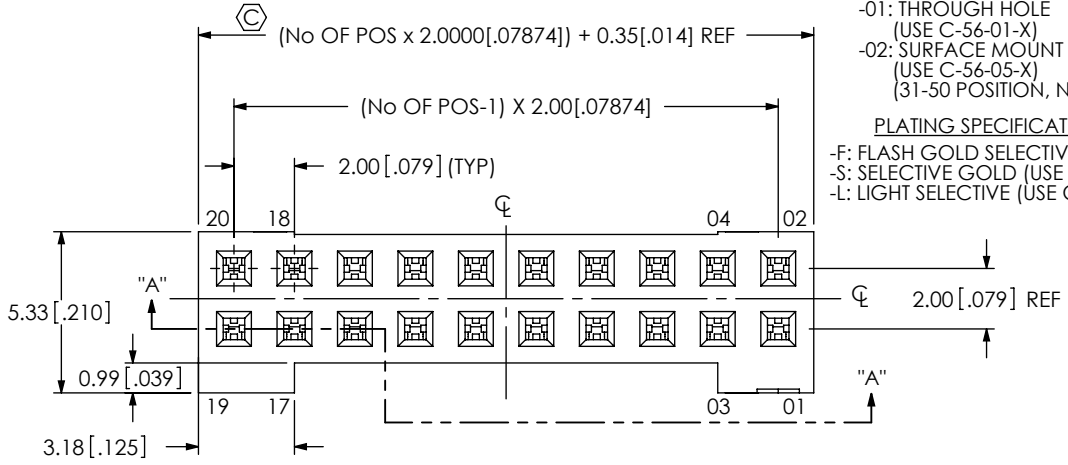

SECTION "A"-"A"

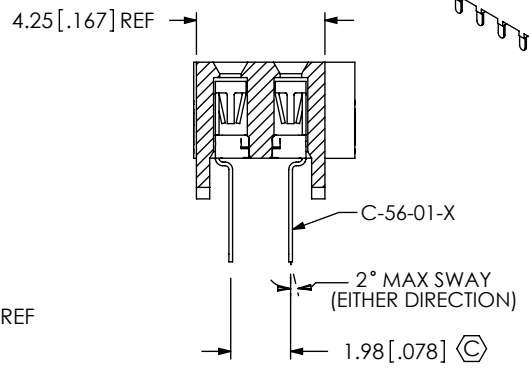

SECTION "B"-"B"

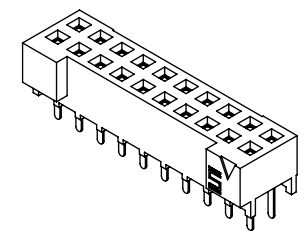

FIG 1  
S2M-110-01-XX-D SHOWN

NOTES:

1. Ⓞ REPRESENTS A CRITICAL DIMENSION.
2. MINIMUM CONTACT RETENTION FORCE: 4.45 N [1.000 LB.].
3. "LC" OPTION FOR A -02 POSITION WILL HAVE ONLY ONE LOCKING CLIP (LC-07-X).
4. MINIMUM RETENTION FOR LOCKING CLIP, WELD TAB & ACCRT: 3.3 N [.75 LB.].

UNLESS OTHERWISE SPECIFIED, DIMENSIONS ARE IN MILLIMETERS. TOLERANCES ARE:  
DECIMALS ANGLES  
X.X: ±0.3[.01] 2°  
X.XX: ±0.13[.005]  
X.XXX: ±0.051[.0020]

PROPRIETARY NOTE  
THIS DOCUMENT CONTAINS CONFIDENTIAL AND PROPRIETARY INFORMATION AND ALL DESIGN, MANUFACTURING, REPRODUCTION, USE, PATENT RIGHTS AND SALES RIGHTS ARE EXPRESSLY RESERVED BY SAMTEC, INC. THIS DOCUMENT SHALL NOT BE DISCLOSED, IN WHOLE OR PART, TO ANY UNAUTHORIZED PERSON OR ENTITY NOR REPRODUCED, TRANSFERRED OR INCORPORATED IN ANY OTHER PROJECT IN ANY MANNER WITHOUT THE EXPRESS WRITTEN CONSENT OF SAMTEC, INC.

**samtec**  
520 PARK EAST BLVD, NEW ALBANY, IN 47150  
PHONE: 812-944-6733 FAX: 812-948-5047  
e-Mail: info@SAMTEC.com code: 55322

MATERIAL: DO NOT SCALE DRAWING SHEET SCALE: 4:1  
LCP COLOR: BLACK  
CONTACT: BeCu

DESCRIPTION: 2mm DOUBLE ROW SOCKET STRIP

DWG. NO. S2M-1XX-XX-X-D-XX-XX

BY: T NEWTON 09-16-2010 SHEET 1 OF 4

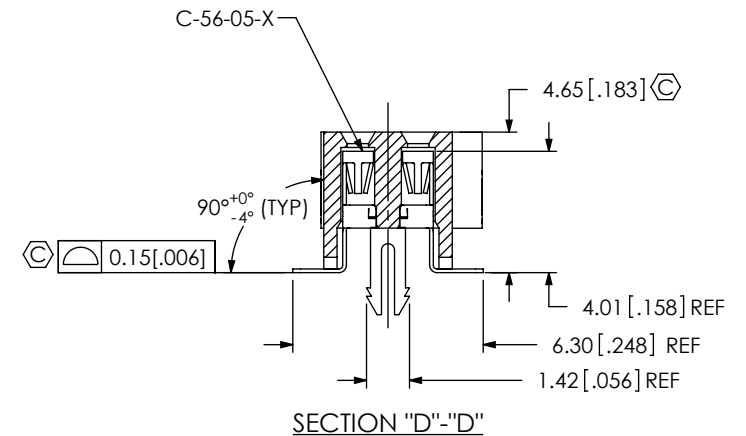
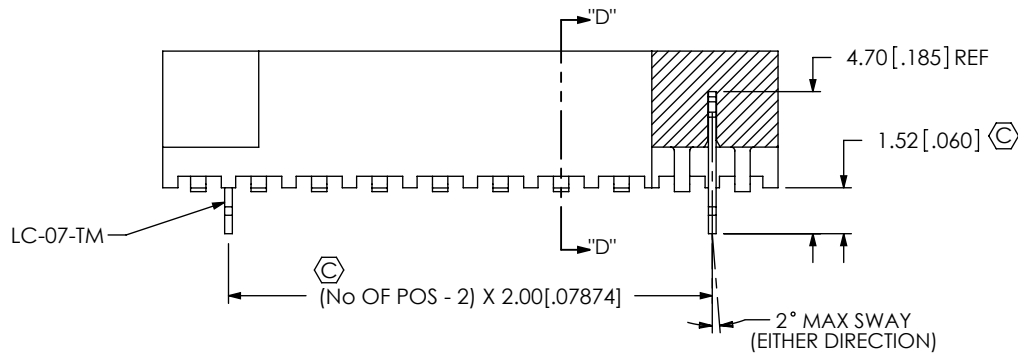
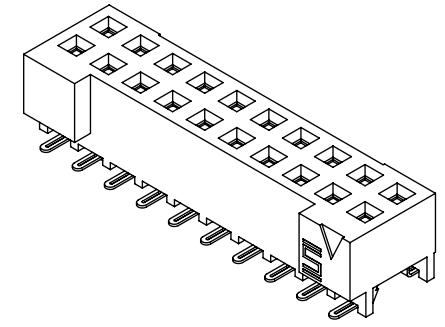
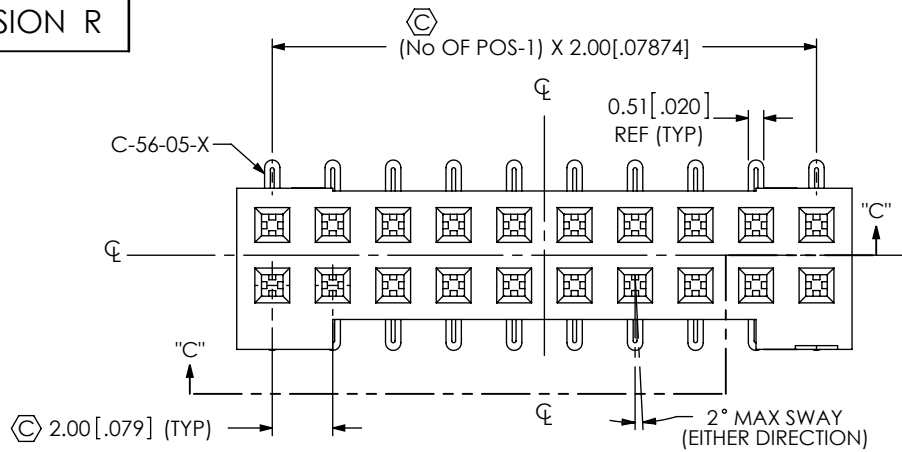

SECTION "C"-C"

FIG 2  
S2M-110-02-X-D-LC SHOWN  
(SAME AS FIG 1, EXCEPT AS SHOWN)

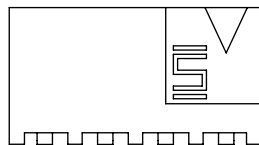
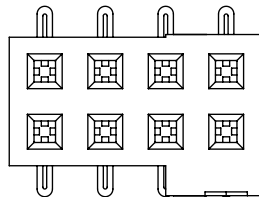

FIG 6  
S2M-104-02-X-D SHOWN  
(SAME AS FIG 1, EXCEPT AS SHOWN)

F:\DWG\MISC\MKTG\S2M-1XX-XX-X-D-XX-XX-MKT.SLDDRW

**PROPRIETARY NOTE**  
THIS DOCUMENT CONTAINS CONFIDENTIAL AND PROPRIETARY INFORMATION AND ALL DESIGN, MANUFACTURING, REPRODUCTION, USE, PATENT RIGHTS AND SALES RIGHTS ARE EXPRESSLY RESERVED BY SAMTEC, INC. THIS DOCUMENT SHALL NOT BE DISCLOSED, IN WHOLE OR PART, TO ANY UNAUTHORIZED PERSON OR ENTITY NOR REPRODUCED, TRANSFERRED OR INCORPORATED IN ANY OTHER PROJECT IN ANY MANNER WITHOUT THE EXPRESS WRITTEN CONSENT OF SAMTEC, INC.

DO NOT SCALE DRAWING

SHEET SCALE: 4:1



520 PARK EAST BLVD, NEW ALBANY, IN 47150  
PHONE: 812-944-6733 FAX: 812-948-5047  
e-Mail: info@SAMTEC.com code: 55322

DESCRIPTION:  
2mm DOUBLE ROW SOCKET STRIP

DWG. NO.  
S2M-1XX-XX-X-D-XX-XX

BY: T NEWTON 09-16-2010 SHEET 2 OF 4

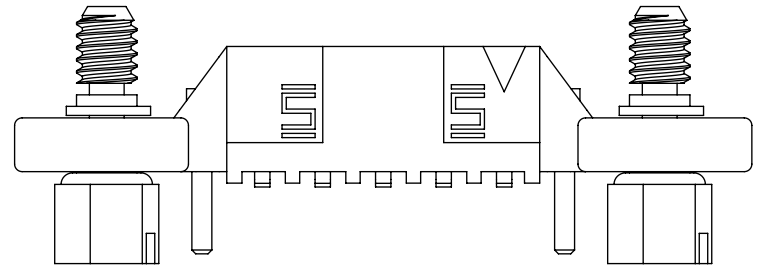
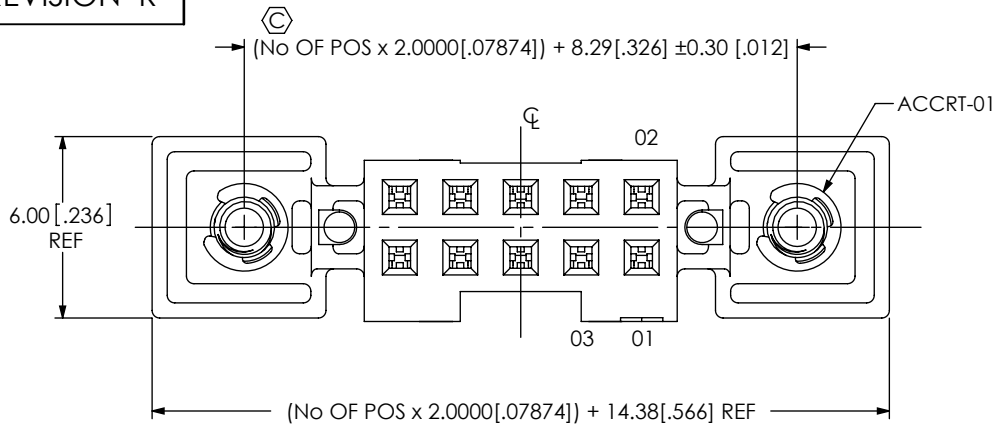

FIG 5  
S2M-105-02-X-D-DS SHOWN  
(SAME AS FIG 4, EXCEPT AS SHOWN)

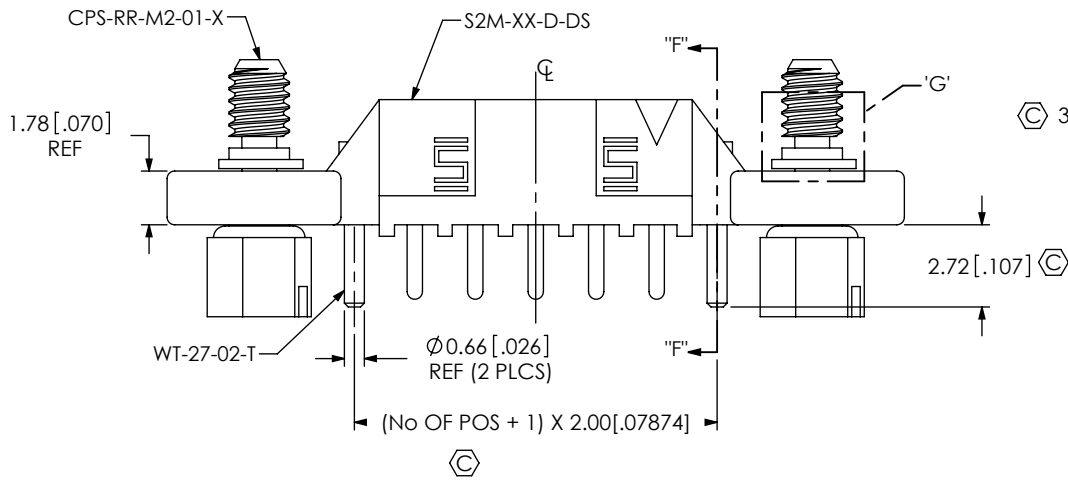
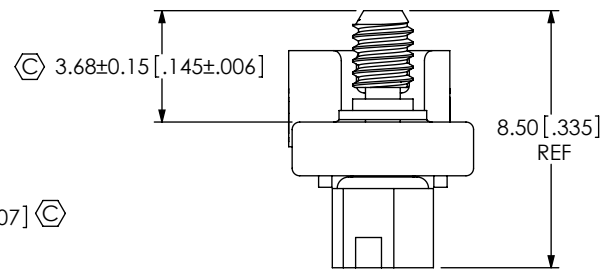
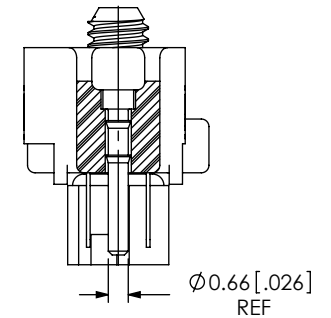

FIG 4  
S2M-105-01-X-D-DS SHOWN  
(SAME AS FIG 1, EXCEPT AS SHOWN)



DETAIL 'G'  
SCALE 8 : 1



SECTION "F"- "F"

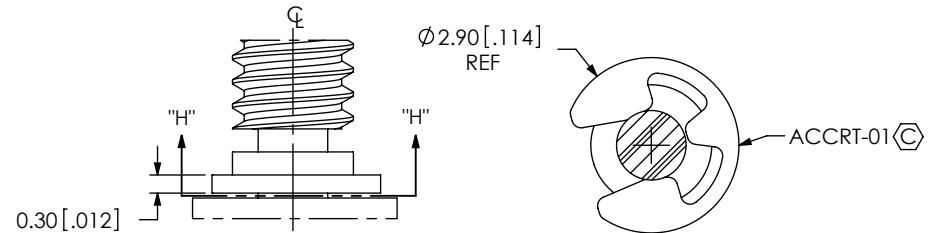

SECTION "H"- "H"  
SCALE 8 : 1

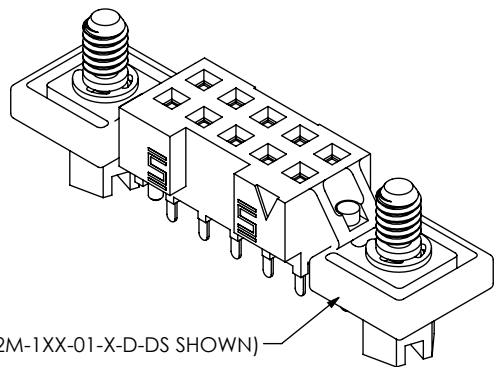

(S2M-1XX-01-X-D-DS SHOWN)

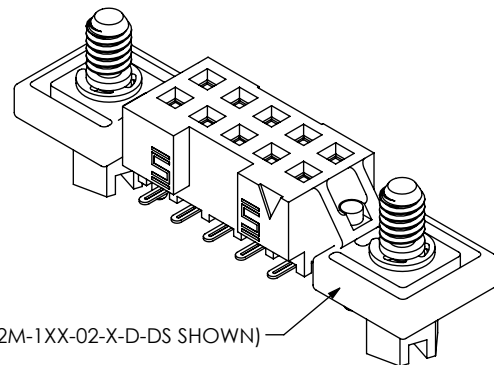

(S2M-1XX-02-X-D-DS SHOWN)

**PROPRIETARY NOTE**  
THIS DOCUMENT CONTAINS CONFIDENTIAL AND PROPRIETARY INFORMATION AND ALL DESIGN, MANUFACTURING, REPRODUCTION, USE, PATENT RIGHTS AND SALES RIGHTS ARE EXPRESSLY RESERVED BY SAMTEC, INC. THIS DOCUMENT SHALL NOT BE DISCLOSED, IN WHOLE OR PART, TO ANY UNAUTHORIZED PERSON OR ENTITY NOR REPRODUCED, TRANSFERRED OR INCORPORATED IN ANY OTHER PROJECT IN ANY MANNER WITHOUT THE EXPRESS WRITTEN CONSENT OF SAMTEC, INC.

DO NOT SCALE DRAWING

SHEET SCALE: 4:1

**samtec**

520 PARK EAST BLVD, NEW ALBANY, IN 47150  
PHONE: 812-944-6733 FAX: 812-948-5047  
e-Mail: info@SAMTEC.com code: 55322

DESCRIPTION: 2mm DOUBLE ROW SOCKET STRIP

DWG. NO. S2M-1XX-XX-X-D-XX-XX

BY: T NEWTON 09-16-2010 SHEET 3 OF 4

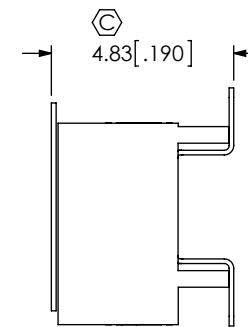
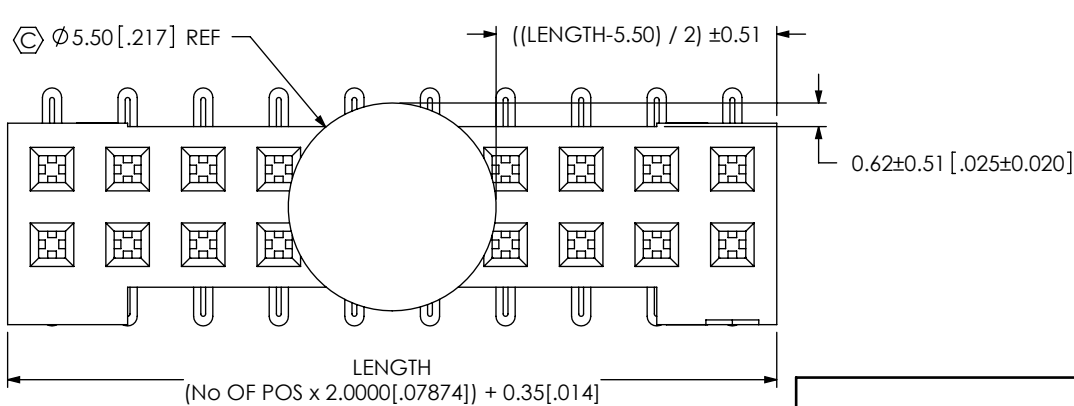

**FIG 3**  
S2M-110-02-X-D-K SHOWN  
(SAME AS FIG 2, EXCEPT AS SHOWN)

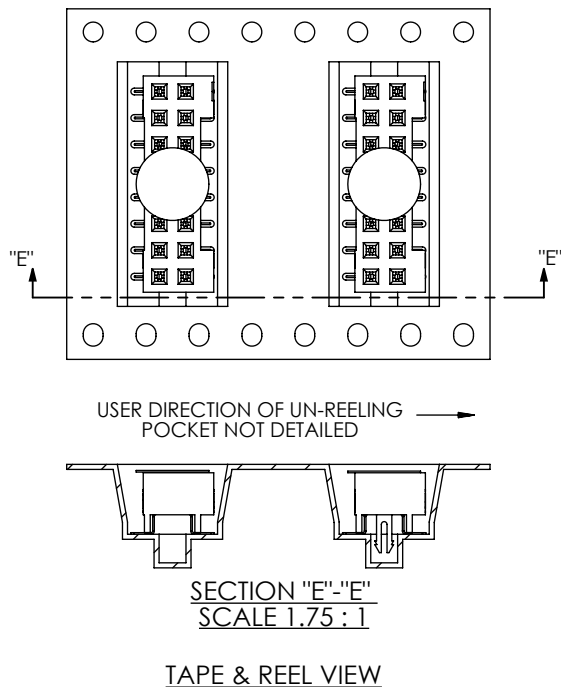

**PACKAGING VIEW**  
(#1 PIN OPPOSITE THE DIRECTION ARROW ON THE TUBE)

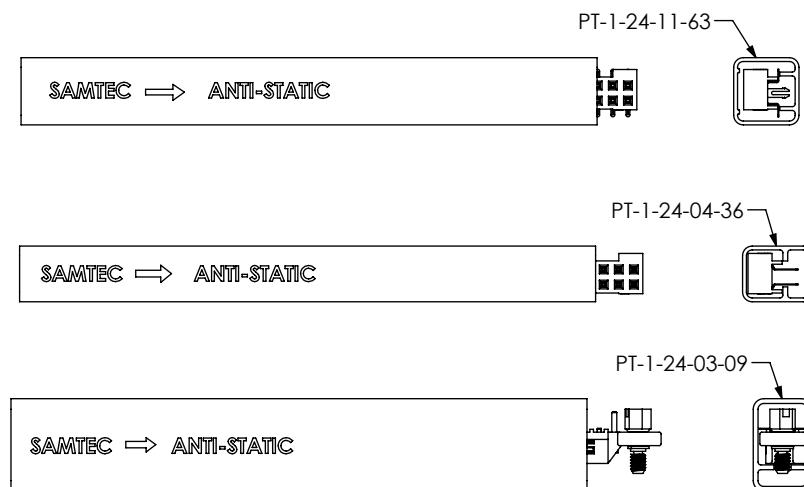

TUBE TABLE		
LEAD STYLE	TUBE	PLUG
-01	PT-1-24-04-36	TP-09
-02	PT-1-24-11-63	TP-24
-XX-DS	PT-1-24-03-09	TP-03

F:\DWG\MISC\MKTG\S2M-1XX-XX-X-D-XX-XX-MKT.SLDDRW

**PROPRIETARY NOTE**  
THIS DOCUMENT CONTAINS CONFIDENTIAL AND PROPRIETARY INFORMATION AND ALL DESIGN, MANUFACTURING, REPRODUCTION, USE, PATENT RIGHTS AND SALES RIGHTS ARE EXPRESSLY RESERVED BY SAMTEC, INC. THIS DOCUMENT SHALL NOT BE DISCLOSED, IN WHOLE OR PART, TO ANY UNAUTHORIZED PERSON OR ENTITY NOR REPRODUCED, TRANSFERRED OR INCORPORATED IN ANY OTHER PROJECT IN ANY MANNER WITHOUT THE EXPRESS WRITTEN CONSENT OF SAMTEC, INC.

DO NOT SCALE DRAWING

SHEET SCALE: 4:1



520 PARK EAST BLVD, NEW ALBANY, IN 47150  
PHONE: 812-944-6733 FAX: 812-948-5047  
e-Mail: info@SAMTEC.com code: 55322

DESCRIPTION:  
2mm DOUBLE ROW SOCKET STRIP

DWG. NO.  
S2M-1XX-XX-X-D-XX-XX

BY: T NEWTON 09-16-2010 SHEET 4 OF 4