

Recommended PCB Layout

Tolerance: $\pm 0.05\text{mm}$

□ Component Outline

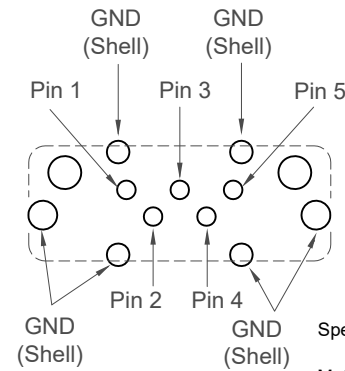

PCB Pin Number Description

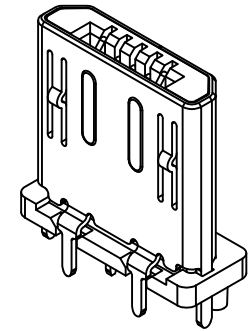

Specifications 规格

Materials 材料:

Plastic Housing 塑胶外壳: LCP, UL94V-0, Black
 Contact Terminal 接触端子: Copper Alloy
 Metallic Shell 金属外壳: Stainless Steel

Plating 电镀:

Underplating 底层电镀: $50\mu\text{m}$ Nickel min.
 Finish 表面处理: Contact Area 接触面积: $30\mu\text{m}$ Gold plating
 Solder Tails 焊接末端: Matte Tin
 Metallic Shell 金属外壳: Nickel

Electrical 电气规格:

Voltage Rating 电压额定值: 30 V AC
 Current Rating 电流额定值: Signal (Pins 2,3,4)信号: 1.0 A.
 Power (Pins 1,5)电源: 1.8A.
 Operating Temperature 工作温度: -30°C to $+85^\circ\text{C}$.
 Contact Resistance 接触电阻值: 30 m Ω max.
 Insulating Resistance 绝缘电阻值: 1000 M Ω min.
 Dielectric Withstand Voltage 耐压: 500V AC/Minute

Mechanical 机械性规格:

Mating Force 插入力: 35N max.
 Unmating Force 拨出力: 8N min.
 Durability 耐久性: 10,000 cycles

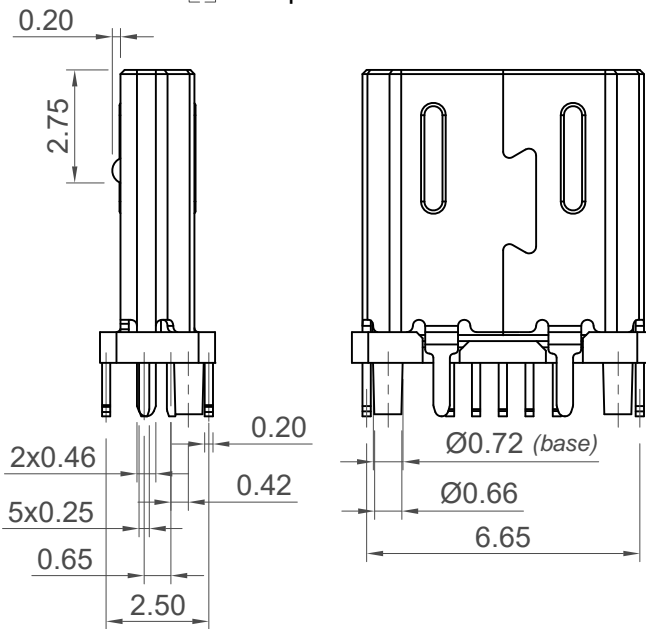
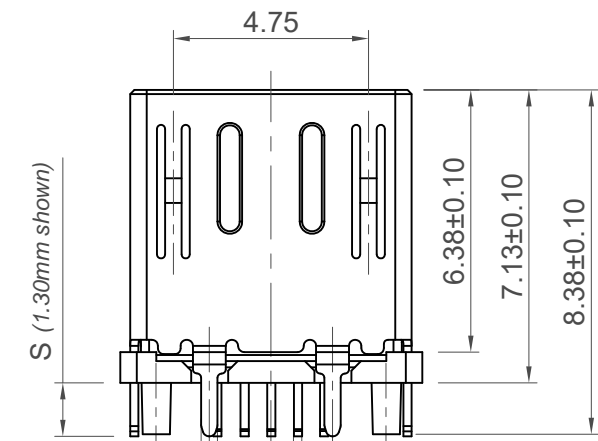

Designed to comply with physical, electrical and environmental requirements of Micro USB Standard (USB2.0)

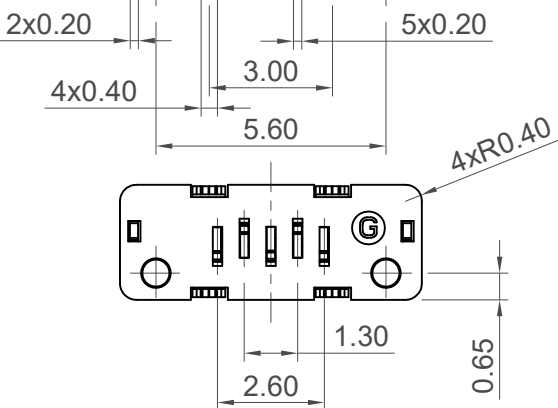

Ordering Grid

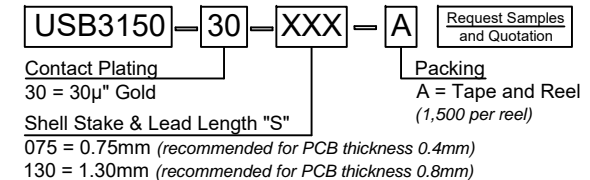

Part Number: USB3150
 Product Description: μ USB Plug - Type B, Through-Hole Vertical, with Shell Stakes and Locating Pegs

By	AJO	Tolerances (Except as Noted)	Units:
Detail	Drawing Release	Length	Metric (mm)
Revision	A1	Angle	
Date	10/08/15	$X.X \pm 0.10$	$X^\circ \pm 2.0^\circ$
		$X.XX \pm 0.05$	$X.X^\circ \pm 1.0^\circ$



This drawing is confidential and copyright of Global Connector Technology, Ltd (GCT). This drawing must not be copied or disclosed without written consent. E & OE



Not to Scale	Drawn By AJO	Sheet No. 1/2
--------------	--------------	---------------

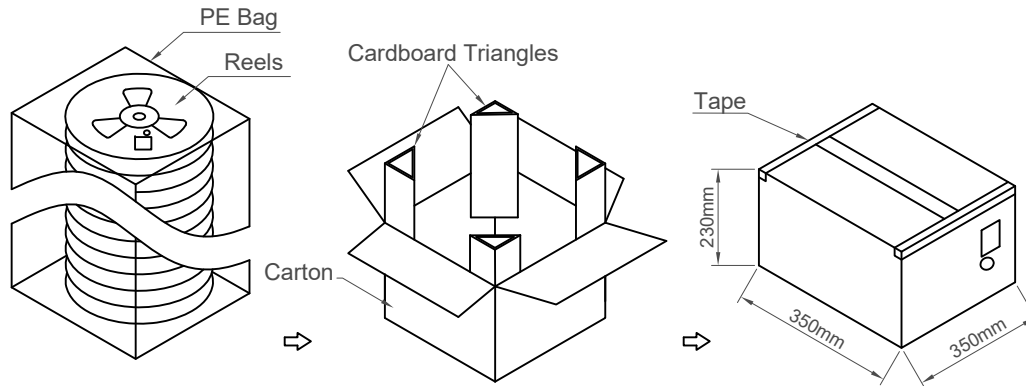
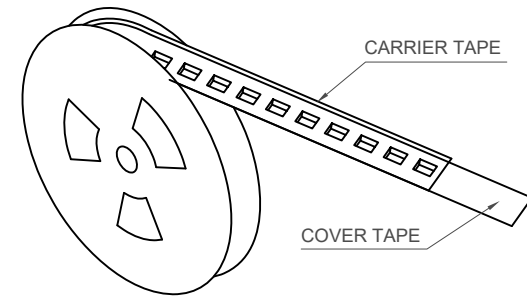
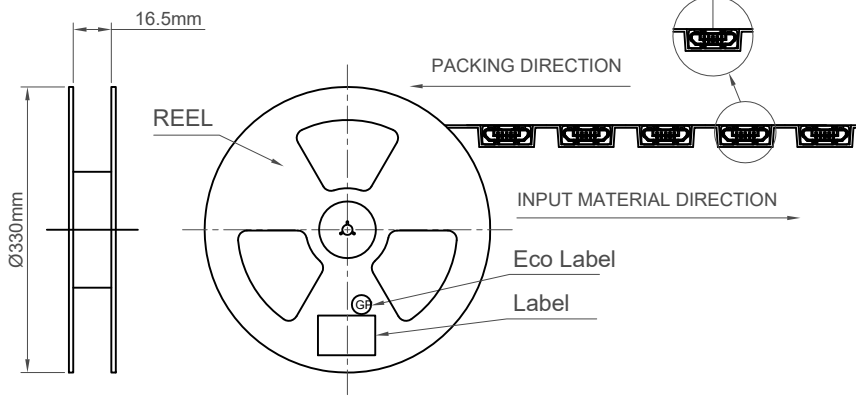
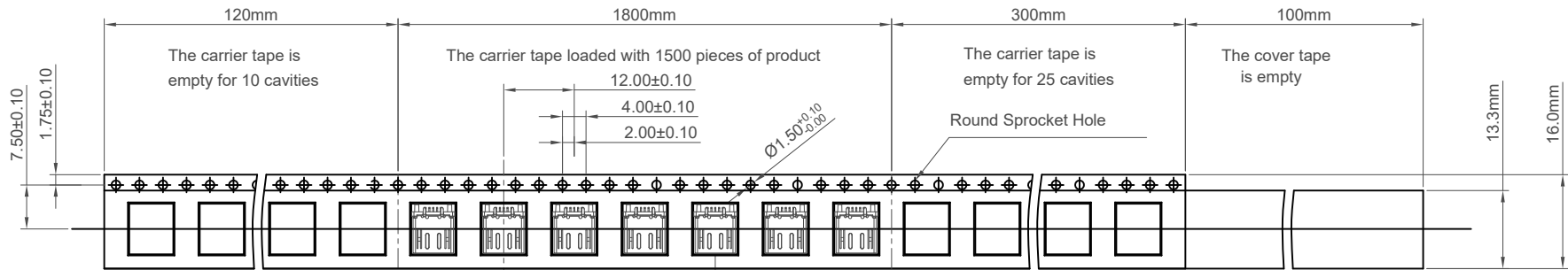

Part Number	Specification	Q'ty
Carrier Tape	16.0mm (W) x 18.42m (L)	10
Cover Tape	13.3mm (W)	185.2m
Reel	330 x 21mm	10
Bag	400 x 400 x 400mm, PE	1
Cardboard Triangles	430 x 215 x 3mm	4
Carton	350 x 350 x 230mm	1
Desiccant	3.5g	2

Part Number	Pcs./Reel	Reels/Carton	Pcs./Carton
USB3150	1500	10	15000

Part Number USB3150		Product Description µUSB Plug - Type B, Through-Hole Vertical, with Shell Stakes and Locating Pegs	
Drawing Date 30th April 2015			
By AJO	Release A1	Tolerances (Except as Noted) Length X.X ± 0.10 X.XX ± 0.05	Units: Metric (mm) Angle X.° ± 2° X.X° ± 1°
Detail	Date 10/08/15	3rd Angle Projection	
This drawing is confidential and copyright of Global Connector Technology, Ltd (GCT). This drawing must not be copied or disclosed without written consent. E & OE			



Not to Scale	Drawn By AJO	Sheet No. 2/2
--------------	-----------------	------------------