

DRAWING FILE NO. AA1-B0-34-615-5D1-C		REV 07-19-17
REVISIONS		
DATE	DESCRIPTION	
07-19-17	DRAWING CREATED	

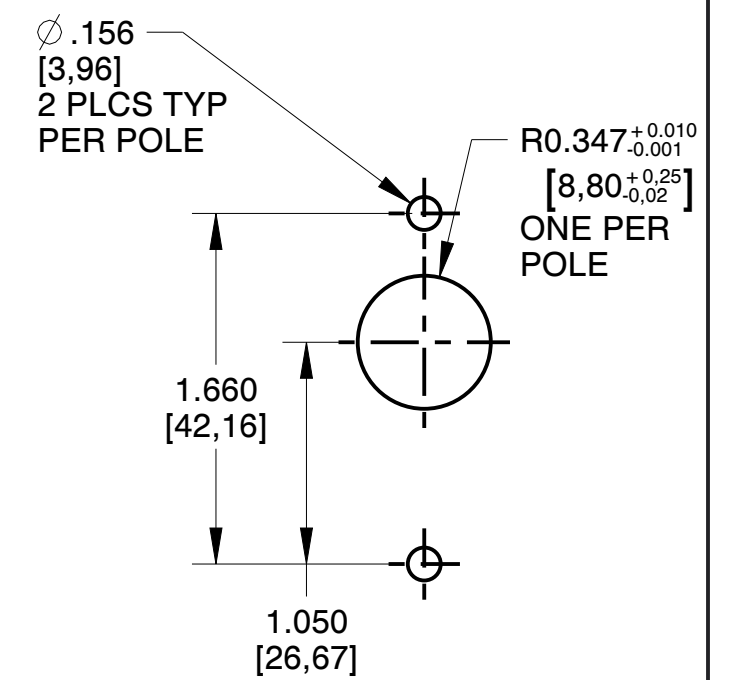
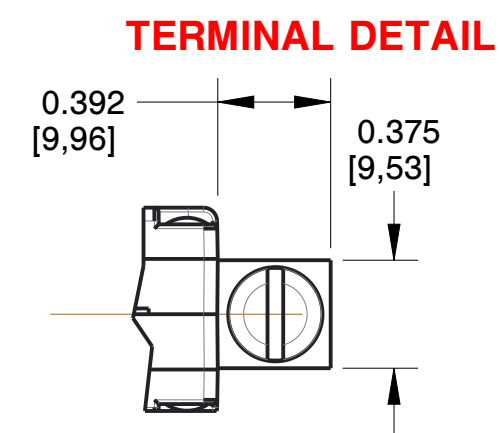
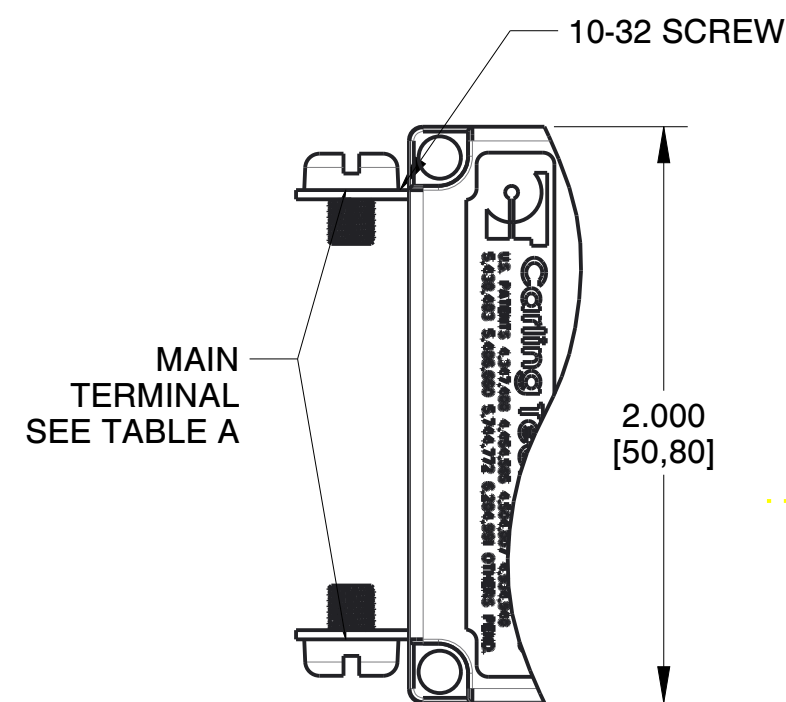
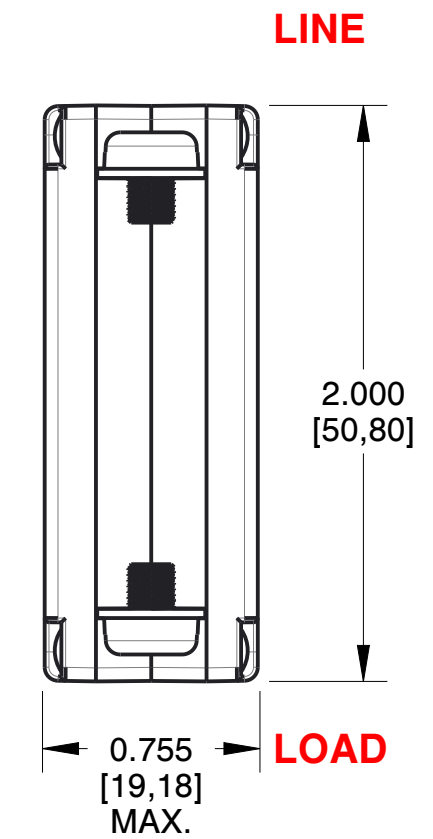
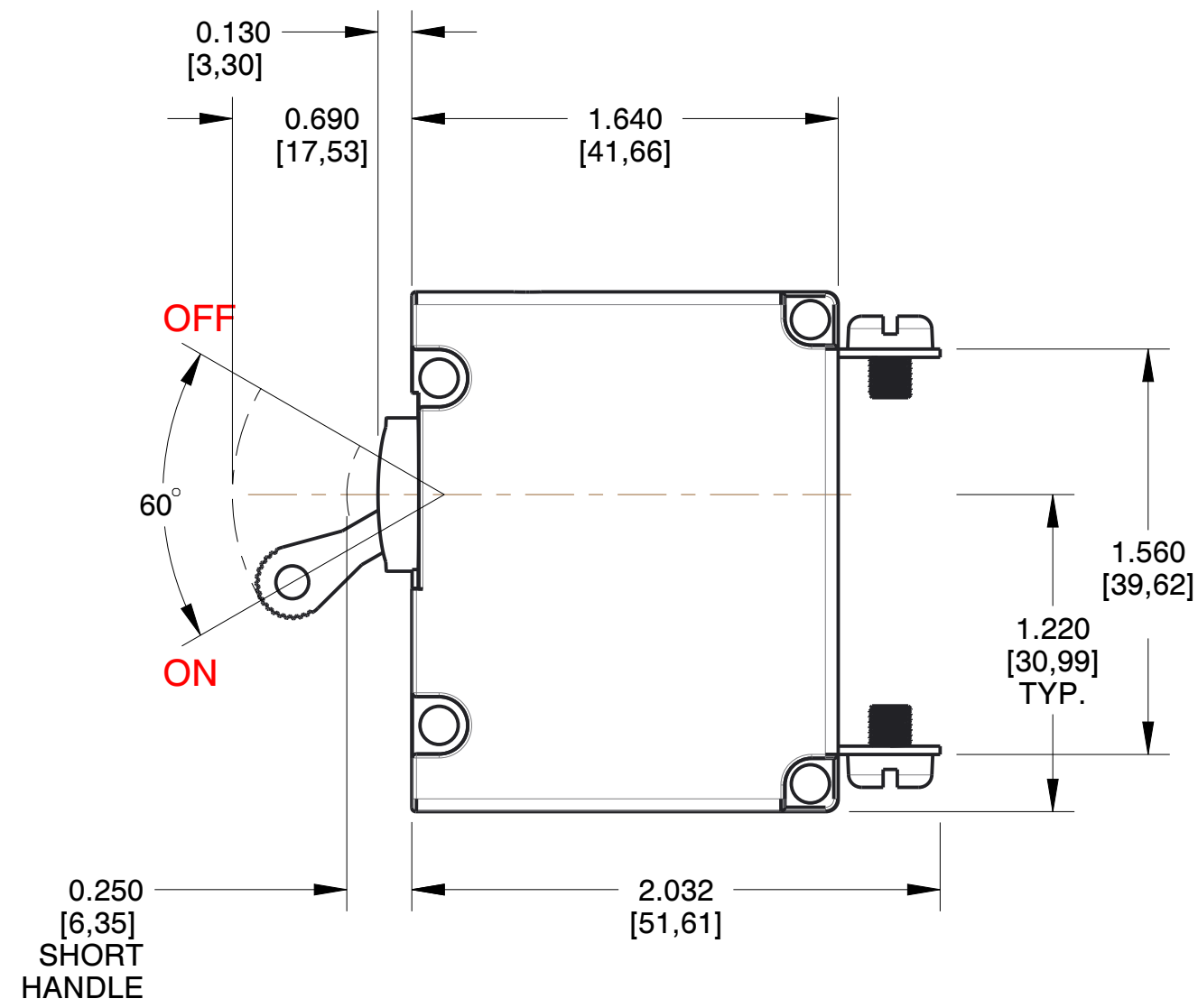
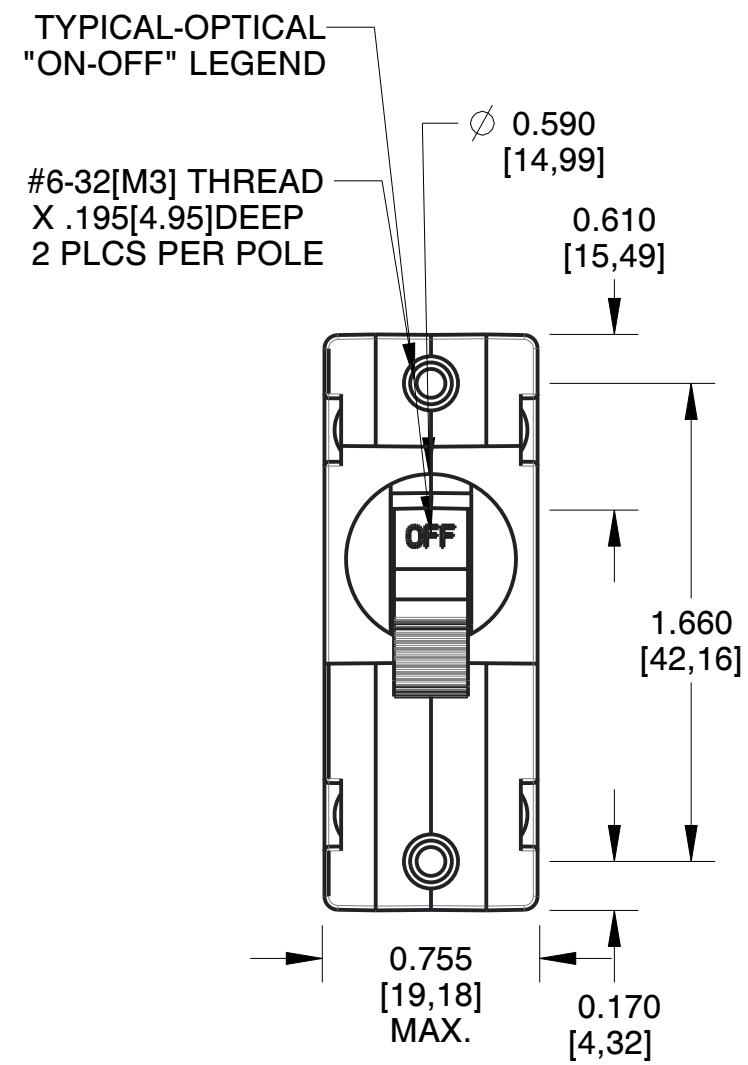

**PANEL CUTOUT DETAIL**

**Carling Technologies**  
Innovative Designs. Powerful Solutions.

60 JOHNSON AVE  
PLAINVILLE, CT 06062, USA  
PHONE: (860) 793-9281  
SALES: SALES@CARLINGTECH.COM  
APPLICATION SUPPORT: TEAM2@CARLINGTECH.COM

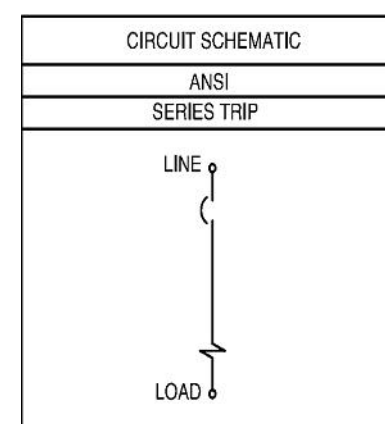

TABLE A TIGHTENING TORQUE SPECIFICATIONS	
THREAD SIZE	TORQUE
#6-32 & M3 MOUNTING HARDWARE	7-9- IN-LBS [0.8-1.0 NM]
#8-32 & M4 THREAD TERMINAL SCREW	12-15 IN-LBS [1.4-1.7 NM]
#10-32 & M5 THREAD TERMINAL SCREW	15-20 IN-LBS [1.7-2.3 NM]

**PROPRIETARY NOTICE**  
NOTICE TO ALL PERSONS RECEIVING THIS DRAWING: THIS DOCUMENT IS THE PROPERTY OF CARLING TECHNOLOGIES, INC. AND IS NOT TO BE DISCLOSED, REPRODUCED IN WHOLE OR IN PART OR USED FOR MANUFACTURING PURPOSES BY ANYONE WITHOUT THE CONSENT OF CARLING TECHNOLOGIES, INC.

**DISCLAIMER**  
MANUFACTURER RESERVES THE RIGHT TO CHANGE PRODUCT SPECIFICATIONS WITHOUT PRIOR NOTICE.

**A-SERIES  
CIRCUIT\_BREAKER**

DO NOT SCALE DRAWING  
UNLESS OTHERWISE SPECIFIED  
DIMENSIONS: IN [MM]  
TOLERANCES: ± .020 [0.51]

DRAWING FILE NO. AA1-B0-34-615-5D1-C SIZE C  
PRODUCT SERIES: A-SERIES C.B. SHEET 1 OF 1