

THIS COPY IS PROVIDED ON A RESTRICTED BASIS AND IS NOT TO BE USED IN ANY WAY DETRIMENTAL TO THE INTERESTS OF PANDUIT CORP.

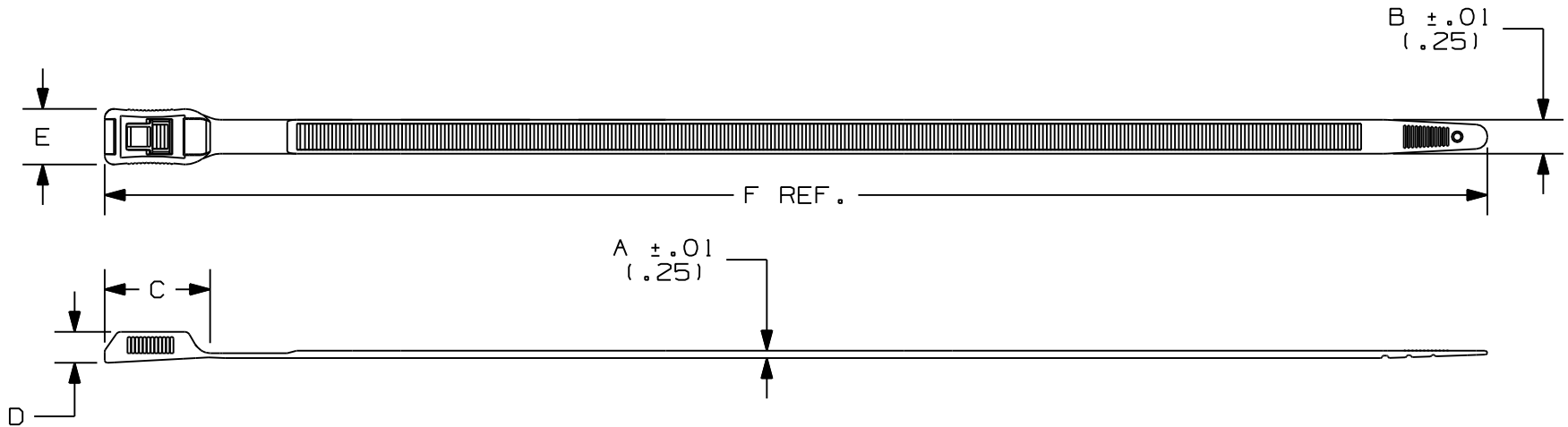

PANDUIT PART NO.	BUNDLE DIA.		A in (mm)	B in (mm)	C in (mm)	D in (mm)	E in (mm)	F in (mm)	MIN. LOOP TENSILE* lbs. (N)	CROSS SECTION	WEIGHT 100 pcs lbs (g)
	MIN. in (mm)	MAX. in (mm)									
HV965	.39 (10)	2.6 (65)	.076 (1.9)	.350 (8.9)	1.093 (27.7)	.318 (8.0)	.571 (14.5)	10.43 (265)	160 (710)	LIGHT HEAVY	1.02 (462)
HV9100	.39 (10)	3.9 (100)	.076 (1.9)	.350 (8.9)	1.093 (27.7)	.318 (8.0)	.571 (14.5)	14.43 (367)	160 (710)	LIGHT HEAVY	1.36 (617)
HV9150	.39 (10)	5.9 (150)	.076 (1.9)	.350 (8.9)	1.093 (27.7)	.318 (8.0)	.571 (14.5)	20.65 (525)	160 (710)	LIGHT HEAVY	1.84 (845)
HV9250	.39 (10)	9.8 (250)	.076 (1.9)	.350 (8.9)	1.093 (27.7)	.318 (8.0)	.571 (14.5)	33.12 (841)	160 (710)	LIGHT HEAVY	2.85 (1295)

\* PER SAE AS23190

CONFORMS TO EN50146

- MINIMUM INSTALLATION TEMP: -25°C
- MAXIMUM APPLICATION TEMP: 85°C
- MINIMUM APPLICATION TEMP: -60°C
- MINIMUM LOOP TENSILE STRENGTH: 710N
- FLAME APPLICATION TIME: 10s

CAD FILENAME/LAYERS

DIMENSIONS IN PARENTHESIS ARE IN METRIC

PANDUIT CORP. TINLEY PARK, ILLINOIS

HYPER-V IN-LINE TIE

UNLESS OTHERWISE SPECIFIED,  
DIMENSIONAL TOLERANCES ARE:  
(.X) ± .1 (XXX) ± .02  
(.XX) ± .02 ANGLES ± 5°

UNLESS OTHERWISE SPECIFIED,  
ALL DIMENSIONS ARE GIVEN  
IN INCHES, THIRD ANGLE PROJECTION.

DRAWN BY  
FAB

MAT'L:

SCALE  
NONE

DATE  
4/07/06

NYLON 6.6

DRAWING NO.  
SS-27504

DWG  
A  
SIZE

4	10/31/06	ERW		ADDED EN50146 NOTES	27504	4					
REV	DATE	BY	CHK	DESCRIPTION	ECN	R	CUST	SUP			