

THIS DRAWING IS UNPUBLISHED. RELEASED FOR PUBLICATION 2007
 © COPYRIGHT 2007 ALL RIGHTS RESERVED.

REVISIONS				DATE	DWN	APVD
P	LTR	DESCRIPTION				
Y9		TIN PLATING RANGE ADDED AND NEW SILVER PLATED PRELIMINARY PART 3-928776-6 ADDED	21MAR2017	KJK	PS	

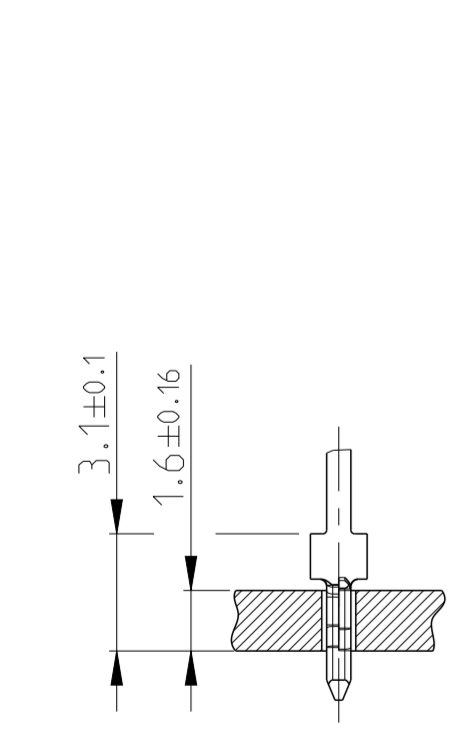

ROTATION PERMITTED
 VERDREHUNG ERLAUBT

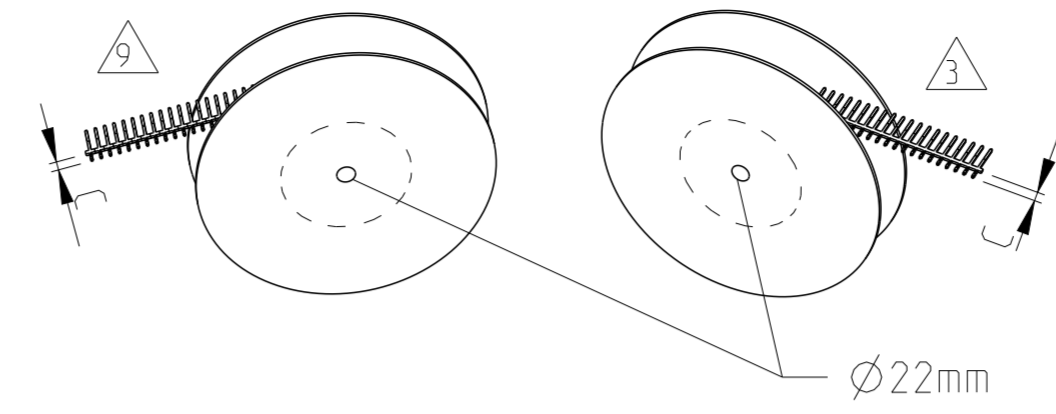
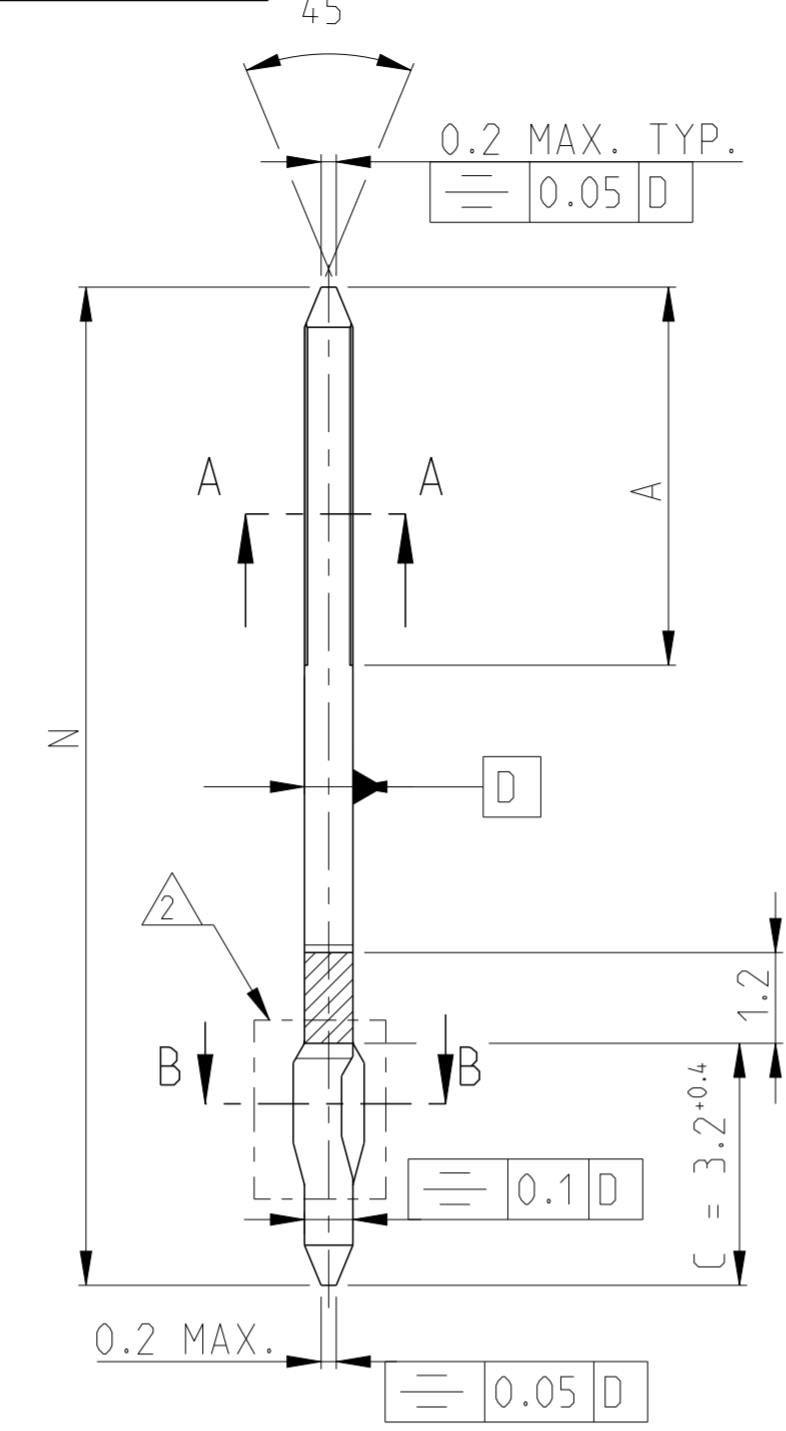
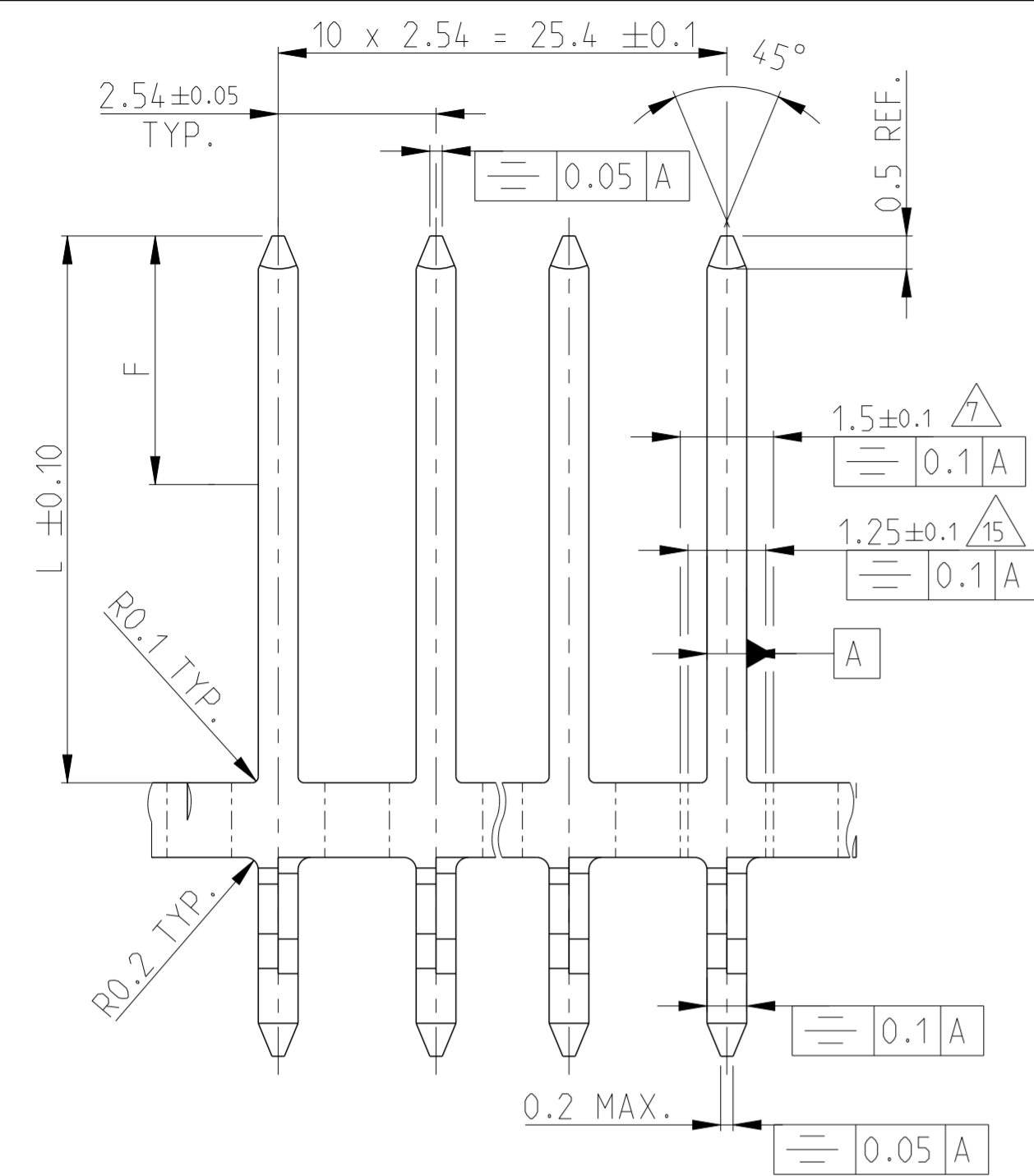
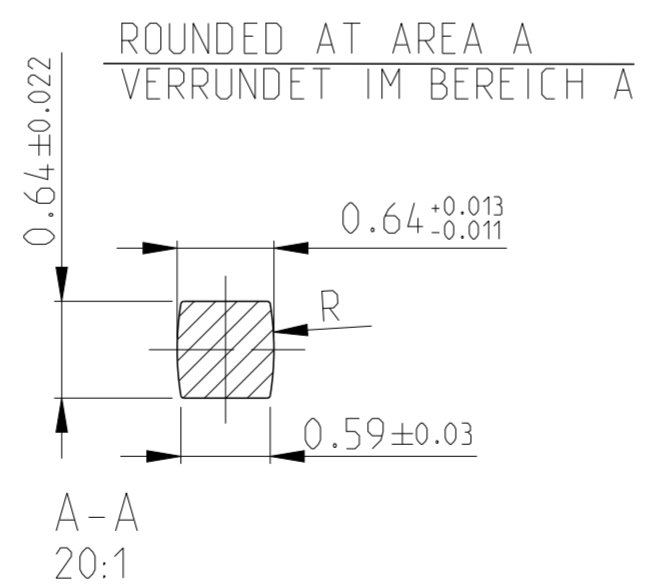
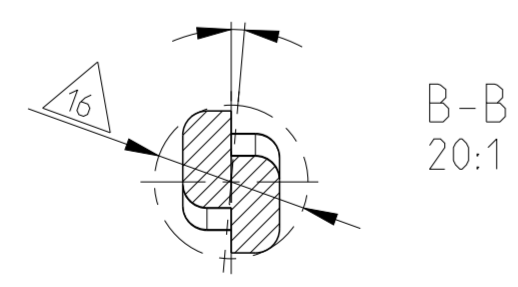

SURFACE	A	F	L	REV.	ORDER NO. (STRIP)	ORDER NO. (LOOSE PIECE)	REEL THICKN.	ENVELOPE CIRCLE
20	11.4	7.0	12.4	1	3-928776-6	-	35	Ø1.13±0.06
6	8.5	6.0	8.8	A	4-928776-4	-	26	Ø1.13±0.06
1	6.0	5.5	6.25	Y	5-928776-8	-	30	Ø1.05±0.04
1	6.7	6.7	7.05	Y	5-928776-6	-	30	Ø1.05±0.04
13	8.0	8.0	16.8	Y	2-928776-7	2-928836-7	44	Ø1.13±0.06
1	11.4	11.2	12.4	Y	2-928776-6	2-928836-6	35	
1	8.5	5.5	8.8	Y	5-928776-4	5-928836-4	32	
14	4.8	4.8	5.6	A	3-928776-5	-	30	
6	8.5	6.0	8.8	Y	3-928776-4	3-928836-4	32	
6	6.7	6.7	7.05	Y	3-928776-2	3-928836-2	30	
12	4.8	-	5.6	Y	2-928776-5	2-928836-5	30	
10	8.0	-	10.8	Z	2-928776-3	2-928836-3	30	
5	6.7	-	7.05	Y	2-928776-2	2-928836-2	30	
10	19.0	-	20.1	Y	2-928776-1	2-928836-1	44	
1	6.0	5.5	6.25	Y	2-928776-0	2-928836-0	30	
10	4.0	-	4.0	Y	1-928776-9	1-928836-9	30	
10	6.0	-	8.3	Y	1-928776-8	1-928836-8	32	
1	8.0	8.0	16.8	Y	1-928776-7	1-928836-7	44	
10	11.4	-	12.4	Y	1-928776-6	1-928836-6	35	
19	4.8	4.8	5.6	Y	1-928776-5	1-928836-5	30	
14	8.5	8.5	8.8	Y	1-928776-4	1-928836-4	32	
14	8.0	8.0	10.8	Y	1-928776-3	1-928836-3	35	
1	6.7	6.7	7.05	Y	1-928776-2	1-928836-2	30	
1	19.0	19.0	20.1	Y	1-928776-1	1-928836-1	44	

REFER SHEET 2 FOR NOTES

THIS DRAWING IS A CONTROLLED DOCUMENT.

DIMENSIONS: mm

TOLERANCES UNLESS OTHERWISE SPECIFIED:

0 PLC	± 0.2
1 PLC	± 0.2
2 PLC	± 0.2
3 PLC	± 0.2
4 PLC	±
ANGLES	± 3°

MATERIAL: CuSn

SEE NOTES

APVD: G.FELDMER 15 JUN 1986

PRODUCT SPEC: 108-18012

APPLICATION SPEC: -

WEIGHT: -

CUSTOMER DRAWING

DWN: A.HOFFMANN 15 JUN 1986

CHK: M.SCHAARSCHEMIDT 15 JUN 1986

APVD: G.FELDMER 15 JUN 1986

NAME: AMPMODU II ACTION PIN FOR HOLE DIAMETER 0.9mm

STE TE Connectivity

SIZE: A2

CAGE CODE: 00779

DRAWING NO: 928776

RESTRICTED TO: -

SCALE: 10:1

SHEET: 1 OF 2

REV: Y9

LOC		DIST		REVISIONS			
P	LTR	DESCRIPTION	DATE	DWN	APVD		
	-	SEE SHEET 1	-	-	-		

NOTES:

1 AT AREA F MIN 0.8 µm GOLD OVER MIN 1.2 µm NICKEL AT AREA N;
AT AREA C 3.0 -6.0 µm TIN OVER MIN 1.2 µm NICKEL

2 PRESS-IN AREA FOR 1.6mm PCB
REQUIREMENTS FOR PCB HOLE

PLATED HOLE:
DRILL-Ø: 1.0 ±0.025
Cu-THICKN.: 25 - 50 µm
Sn-THICKN.: 4 - 10 µm
FINISHED HOLE-Ø: 0.9 ±0.07

UNPLATED HOLE:
DRILL-Ø: 1.0 ±0.025
FOR SOLDER APPLICATION

ALTERNATIVE-PLATING:
Cu-THICKN.: 25 - 50 µm
Ni-THICKN.: 1.3 - 5 µm
Au-THICKN.: 0.05 - 0.2 µm

9 3 REEL UNIT 50.000 PIECES. REEL-Ø 600mm / Ø588mm
REEL THICKNESS SEE TABLE

4 SOLDERABILITY ACC. TO IEC 60068 - 2 - 20; TEST Ta

5 AT AREA N 3.0-6.0 µm TIN OVER MIN 1.2 µm NICKEL

6 AT AREA F 1-2 µm TIN; AT AREA C 3.0-6.0 µm TIN
OVER MIN 1.2 µm NICKEL

15 7 CUT AREA FOR LOOSE PIECE PARTS DURING THE STITCHING INTO PCB
DIMENSION IS DETERMINED BY THE TOOL OF THE STITCHING MACHINE

8 1000 PIECES ARE PACKED INTO SHOCK-PROOF BOX
AND CLOSED WITH COVER

10 AT AREA N MIN. 2.5 µm TIN OVER MIN 1.2 µm NICKEL

12 AT AREA N 1-2 µm TIN OVER MIN 1.2 µm NICKEL

13 AT AREA F 2-4 µm TIN OVER MIN 1.2 µm NICKEL AT AREA N;
AT AREA C MIN. 1.2 µm TIN OVER MIN 1.2 µm NICKEL

14 AT AREA F MIN 0.8 µm GOLD OVER MIN 1.2 µm NICKEL AT AREA N;
AT AREA C 1.3-2.5 µm TIN OVER MIN 1.2 µm NICKEL

17 OBSOLETE PARTS: OBSOLETE CIS STREAMLINING PER D.RENAUD/D.SINISI

18 OBSOLETE

19 AT AREA F MIN. 1.2 µm GOLD OVER MIN 1.2 µm NICKEL AT AREA N;
AT AREA C 1.3-2.5 µm TIN OVER MIN 1.2 µm NICKEL

20 AT AREA F 1.5-5.0 µm SILVER (WEIGHT% ≥98.0) OVER MIN 1.2 µm NICKEL AT AREA N
AT AREA C 3.0-6.0 µm TIN OVER MIN 1.2 µm NICKEL

21 PRELIMINARY PART

1 IM BEREICH F MIN. 0.8 µm GOLD ÜBER MIN. 1.2 µm NICKEL IM BEREICH N;
IM BEREICH C 3.0-6.0 µm ZINN ÜBER MIN. 1.2 µm NICKEL

2 EINPRESSZONE FÜR 1.6mm LEITERPLATTE
ANFORDERUNG AN DIE LEITERPLATTENBOHRUNG

PLATTIERTES LOCH:
BOHR-Ø: 1.0 ±0.025
Cu-DICKE: 25 - 50 µm
Sn-DICKE: 4 - 10 µm
FERTIGLOCH-Ø: 0.9 ±0.07

NICHT PLATTIERTES LOCH:
BOHR-Ø: 1.0 ±0.025
ZUM LÖTEN

ALTERNATIV-PLATING:
Cu-DICKE: 25 - 50 µm
Ni-DICKE: 1.3 - 5 µm
Au-DICKE: 0.05 - 0.2 µm

9 3 ROLLENEINHEIT 50.000 STIFTE. ROLLEN-Ø 600mm / Ø588mm
ROLLENDICKE SIEHE TABELLE

4 LÖTBARKEIT NACH IEC 60068 - 2 - 20; PRÜFUNG Ta

5 IM BEREICH N 3.0-6.0 µm ZINN ÜBER MIN. 1.2 µm NICKEL

6 IM BEREICH F 1-2 µm ZINN; IM BEREICH C 3.0-6.0 µm ZINN
ÜBER JE MIN. 1.2 µm NICKEL

15 7 SCHNITTSTELLE FÜR EINZELSTIFT BEIM EINSETZEN IN PCB
MAß IST DURCH WERKZEUG AN DER JEWEILIGEN
EINSETZMASCHINE VORGEGEBEN

8 1000 STIFTE IN STOBSICHERE SCHACHTEL VERPACKT
UND MIT DECKEL VERSCHLOSSEN

10 IM BEREICH N MIN. 2.5 µm ZINN ÜBER MIN. 1.2 µm NICKEL

12 IM BEREICH N 1-2 µm ZINN ÜBER MIN. 1.2 µm NICKEL

13 IM BEREICH F 2-4 µm ZINN ÜBER 1.2 µm NICKEL IM BEREICH N;
IM BEREICH C MIN. 1.2 µm ZINN ÜBER MIN. 1.2 µm NICKEL

14 IM BEREICH F MIN. 0.8 µm GOLD ÜBER MIN. 1.2 µm NICKEL IM BEREICH N;
IM BEREICH C 1.3-2.5 µm ZINN ÜBER MIN. 1.2 µm NICKEL

17 OBSOLETE PARTS: OBSOLETE CIS STREAMLINING PER D.RENAUD/D.SINISI

18 OBSOLETE

19 IM BEREICH F MIN. 1.2 µm GOLD ÜBER MIN. 1.2 µm NICKEL IM BEREICH N;
IM BEREICH C 1.3-2.5 µm ZINN ÜBER MIN. 1.2 µm NICKEL

20 IM BEREICH F 1.5-5.0 µm SILBER (GEWICHT% ≥98.0) ÜBER MIN 1.2 µm NICKEL IM BEREICH N;
IM BEREICH C 3.0-6.0 µm ZINN ÜBER MIN. 1.2 µm NICKEL

21 VORLÄUFIGER TEIL

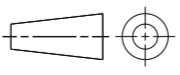
THIS DRAWING IS A CONTROLLED DOCUMENT.		DWN A.HOFFMANN	15 JUN 1986	 TE Connectivity	
DIMENSIONS: mm		CHK M.SCHAARSCHEIDT	15 JUN 1986		
TOLERANCES UNLESS OTHERWISE SPECIFIED:		APVD G.FELDMEIER	15 JUN 1986		
		PRODUCT SPEC	108-18012		
MATERIAL	CuSn	FINISH	SEE NOTES	NAME	AMPMODU II ACTION PIN FOR HOLE DIAMETER 0.9mm
		WEIGHT	-	SIZE	A2
		CUSTOMER DRAWING		CAGE CODE	100779
		SCALE	10:1	DRAWING NO	G-928776
				RESTRICTED TO	-
				SHEET	2 OF 2
				REV	Y9