

TOLERANCE UNLESS OTHERWISE SPECIFIED  
 DIAMETERS  $\epsilon$

ROUGHNESS - 32 CIA  
 DIAMETERS TO BE CONCENTRIC WITHIN -  
 HOLD NORMAL AND PARALLEL FACES WITHIN -

REMOVE ALL BURRS AND BREAK ALL SHARP EDGES  
 DIMENSIONS ARE BEFORE PLATING OR FINISH

DRAWN IN ACCORDANCE WITH BS. 308.  
 THIRD ANGLE PROJECTION. DO NOT SCALE.  
 DIMENSIONS ARE IN MILLIMETRES.

DRAWING No. 59-900091

ISS. A

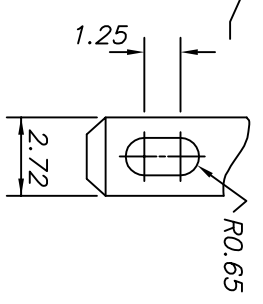
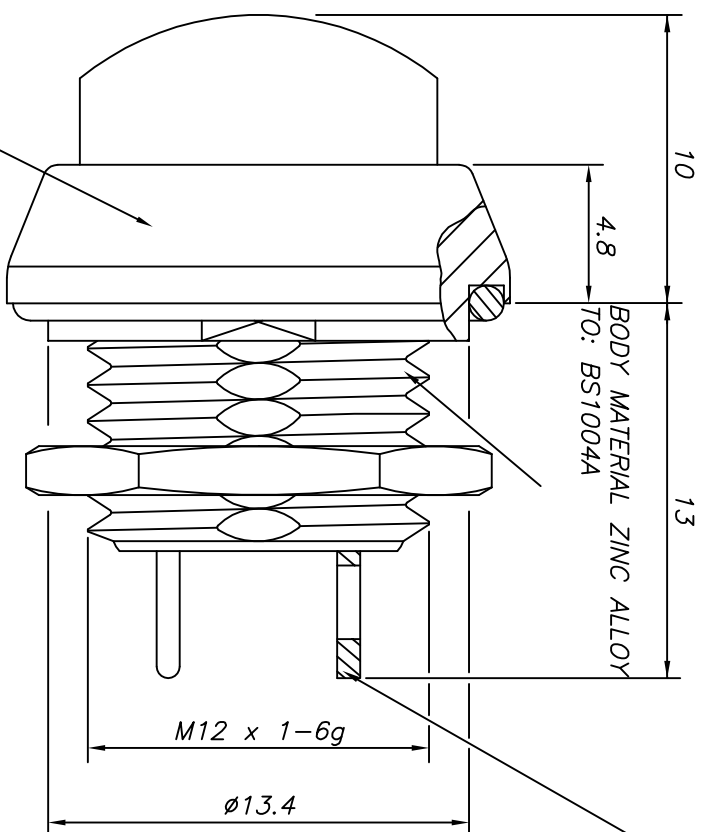
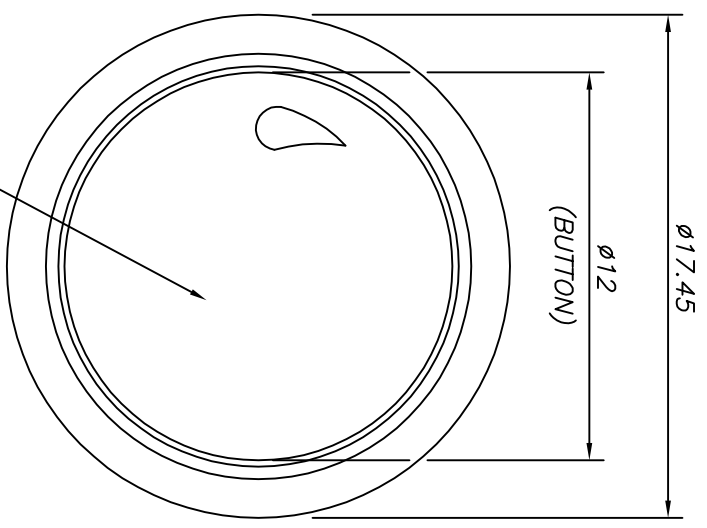

SUGGESTED PANEL CUTOUT

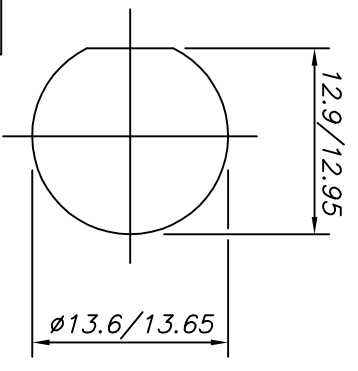

BEZEL FINISH: BLACK P.T.F.E.

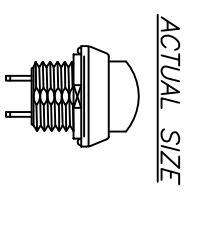

- ELECTRICAL**
- DIELECTRIC STRENGTH 1000VAC
  - INSULATION RESISTANCE 1G Ohms
  - CONTACT RESISTANCE (INITIAL) 50m Ohms
  - CURRENT RATING:-
  - @ 32VAC RESISTIVE 400mA
  - @ 50VDC RESISTIVE 100mA
  - @ 125VAC RESISTIVE 125mA
  - LIFE (MINIMUM) 500,000 CYCLES
  - SWITCHING POWER (MAXIMUM) 16VA AC
- MECHANICAL**
- TRAVEL (NOMINAL) 2.3mm
  - LIFE (MINIMUM) 1,000,000 CYCLES
  - OPERATING FORCE (NOMINAL) 3N
  - ENVIRONMENTAL & PHYSICAL
  - INGRESS PROTECTION IP67
  - SHOCK 100G
  - OPERATING TEMP RANGE -55°C TO +125°C
  - CONTACTS GOLD PLATED - NICKEL

CAD SYSTEM No: 1		DIRECTORY NAME:		CAD DRAWING No: 599091TA.DWG	
ISS.	CHANGE NOTE No.	DATE	DRAWN	ISS.	CHANGE NOTE No.
A	ECN86015	29.11.95	BV		
MATERIAL & SPEC.			SEE GA.		
DRAWN			CHKD.	APPR.	SCALE
BV			NE	ND	5:14.6.96
DATE			TITLE		
6.96			MINIATURE SEALED		
RAISED/ROUND BEZEL P/B			DRAWING No.		
			59-900091		
			ISS.		
			A		

**ITTW Switches**  
 Leon Switches, Chicago Switch, RC/JUD Switches  
 © 1996  
 The Copyright in this drawing and in the article shown belongs to ITW Switches and no reproduction in whole or in part of the drawing or the articles shown may be made without prior written permission.

A3