

RECOMMENDED PCB LAYOUT  
(WITH AND WITHOUT PEGS)  
RECOMMENDED PCB THICKNESS: 1.00±0.10

CIRCUIT SIZE	DIM.A	DIM.B	DIM.C	DIM.D
20	13.90	9.00	12.40	12.22
30	18.90	14.00	17.40	17.22
40	23.90	19.00	22.40	22.22
50	28.90	24.00	27.40	27.22
60	33.90	29.00	32.40	32.22
64	35.90	31.00	34.40	34.22
70	38.90	34.00	37.40	37.22
80	43.90	39.00	42.40	42.22
84	45.90	41.00	44.40	44.22
90	48.90	44.00	47.40	47.22
100	53.90	49.00	52.40	52.22
110	58.90	54.00	57.40	57.22
120	63.90	59.00	62.40	62.22

**NOTES:**

- HOUSING MATERIAL: G.F. THERMOPLASTIC; UL RATING: 94V-0; COLOR: WHITE  
NOTE: HOUSING COLOR FOR - 1664 (ONLY) IS BLACK  
TERMINAL MATERIAL: PHOSPHOR BRONZE; 0.205 THICK  
VACCUM CAP MATERIAL: STAINLESS STEEL; 0.255 THICK
- PLATING ON CONTACTS IS AS FOLLOWS:  
0.00076 MINIMUM GOLD PLATING IN CONTACT AREA,  
0.0019 MINIMUM TIN PLATING IN TERMINAL AREA,  
OVER NICKEL PLATING OVERALL.  
  
\*THE PRIMARY SHIPPING CARTON WILL BE LABELED "COMPLAINT TO RoHS DIRECTIVE 2002/95/EC AND ELV ANNEX II OF DIRECTIVE 2000/53/EC". CARTONS WITHOUT THIS LABEL MAY CONTAIN PRODUCT WITH LEAD.
- THIS PART, WHEN MATED WITH MOLEX 1.0mm PLUG CONNECTOR SERIES 71436, CONFORMS TO MOLEX PRODUCT SPECIFICATION PS-71436-9999. REFER TO CHART ON SHEET 2 FOR MATED STACK HEIGHTS FOR THIS RECEPTACLE.
- PACKAGING SPECIFICATIONS: REFER TO CHART ON SHEET 2.
- PEGS ARE OPTIONAL. REFER TO CHART ON SHEET 2.
- VACCUM PICK & PLACE CAP IS OPTIONAL. REFER TO CHART ON SHEET 2.
- THIS PART CONFORMS TO EIA STANDARD 700 AAAB FOR 1.0mm TWO-PART CONNECTORS FOR USE WITH PARALLEL PRINTED BOARDS.
- COPLANARITY OF SMT TAILS: 0.10 MAX.
- 64-CIRCUIT RECEPTACLE ASSEMBLY WITH PEGS AND VACCUM CAP SHOWN FOR ILLUSTRATION PURPOSES ONLY.
- DATA CODE STAMP IS WEEK, YEAR LOCATED APPROXIMATELY WHERE SHOWN,

SYMBOLS				THIS DRAWING CONTAINS INFORMATION THAT IS PROPRIETARY TO MOLEX ELECTRONIC TECHNOLOGIES, LLC AND SHOULD NOT BE USED WITHOUT WRITTEN PERMISSION			
▽ = 0	mm	SCALE	4:1	CURRENT REV DESC: REDRAWN IN NX			
▽ = 0	GENERAL TOLERANCES (UNLESS SPECIFIED)			<b>molex</b> SALES ASSY, 1.0MM BOARD TO BOARD RECEPTACLE CONNECTOR 7.30 HIGH PRODUCT CUSTOMER DRAWING			
▽ = 0	ANGULAR TOL ± 0.5°						
▽ = 0	4 PLACES	±					
▽ = 0	3 PLACES	±					
▽ = 0	2 PLACES	± 0.13		EC NO: 173770 DRWN: TPREMO 2018/03/13 CHK'D: KLANG 2018/03/23 APPR: KLANG 2018/03/23			
▽ = 0	1 PLACE	± 0.25		INITIAL REVISION: DRWN: REED 1995/04/03 APPR: BIXLER 1995/04/03			
▽ = 0	0 PLACES	±		DOCUMENT NUMBER: 714391000 DOC TYPE: PSD DOC PART: 000 REVISION: A			
▽ = 0	DRAFT WHERE APPLICABLE MUST REMAIN WITHIN DIMENSIONS			MATERIAL NUMBER: SEE TABLE CUSTOMER: GENERAL MARKET SHEET NUMBER: 1 OF 2			
▽ = 0	THIRD ANGLE PROJECTION			DRAWING: C-SIZE SERIES: 71439			

STANDARD

CIRCUIT SIZE	RECEPTACLE ASSY. MATERIAL NUMBER	PEGS	PICK & PLACE CAP	PACKAGING SPEC. NUMBER	PACKAGING TYPE
64	71439-1164	YES	NO	PK-70873-0601	TUBE
64	71439-1364	YES	YES	PK-70873-0607	TUBE
64	71439-1464	YES	YES	PK-70873-063	TAPE & REEL
64	71439-1564	NO	NO	PK-70873-0606	TUBE
64	71439-1664	NO	YES MATTE FINISH	PK-70873-063	TAPE & REEL
64	71439-1764	NO	YES	PK-70873-0606	TUBE
64	71439-1864	NO	YES	PK-70873-063	TAPE & REEL

RECOMMENDED PLUG/RECEPTACLE COMBINATION FOR MATED STACK HEIGHT PER EIA STANDARD 700 AAAB

MATED STACK HEIGHT	RECEPTACLE HEIGHT	RECEPTACLE SERIES NO.	PLUG HEIGHT	PLUG SERIES NO.
11.00	7.30	71439-1***	3.30	71436-1***
12.00	7.30	71439-1***	4.30	71436-2***

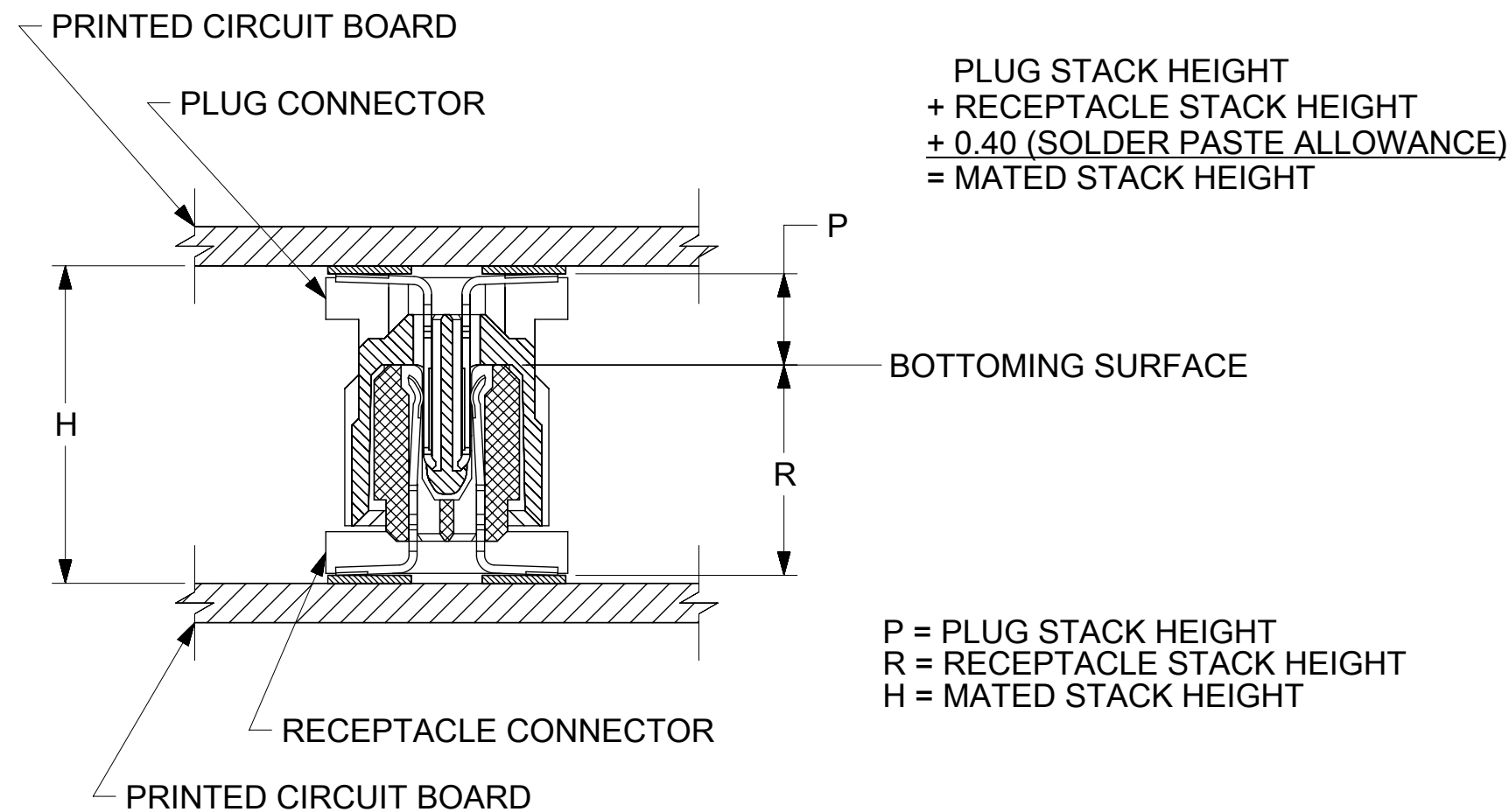

THIS DRAWING CONTAINS INFORMATION THAT IS PROPRIETARY TO MOLEX ELECTRONIC TECHNOLOGIES, LLC AND SHOULD NOT BE USED WITHOUT WRITTEN PERMISSION											
SYMBOLS		DIMENSION UNITS	SCALE	CURRENT REV DESC: REDRAWN IN NX							
▽ = 0 ▽ = 0 ▽ = 0 ▽ = 0 ▽ = 0 ▽ = 0 ▽ = 0 ▽ = 0 ▽ = 0		mm	---	EC NO: 173770 DRWN: TPREMO 2018/03/13 CHK'D: KLANG 2018/03/23 APPR: KLANG 2018/03/23							SALES ASSY, 1.0MM BOARD TO BOARD RECEPTACLE CONNECTOR 7.30 HIGH
▽ = 0 ▽ = 0 ▽ = 0 ▽ = 0 ▽ = 0 ▽ = 0 ▽ = 0 ▽ = 0 ▽ = 0		GENERAL TOLERANCES (UNLESS SPECIFIED) ANGULAR TOL ± 0.5° 4 PLACES ± 3 PLACES ± 2 PLACES ± 0.13 1 PLACE ± 0.25 0 PLACES ±			INITIAL REVISION: DRWN: REED 1995/04/03 APPR: BIXLER 1995/04/03			PRODUCT CUSTOMER DRAWING			
▽ = 0 ▽ = 0 ▽ = 0 ▽ = 0 ▽ = 0 ▽ = 0 ▽ = 0 ▽ = 0 ▽ = 0		DRAFT WHERE APPLICABLE MUST REMAIN WITHIN DIMENSIONS			THIRD ANGLE PROJECTION	DRAWING	SERIES	MATERIAL NUMBER	CUSTOMER	SHEET NUMBER	
						C-SIZE	71439	SEE TABLE	GENERAL MARKET	2 OF 2	