

Sep.1.2018 Copyright 2018 HIROSE ELECTRIC CO., LTD. All Rights Reserved.
 In case that the application demands a high level of reliability, such as automotive,
 please contact a company representative for further information.

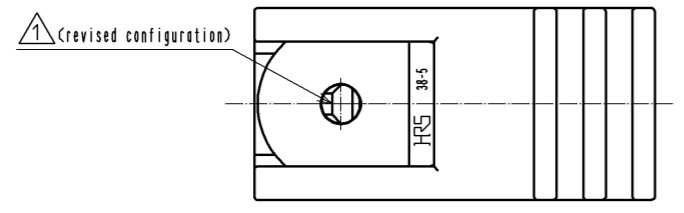

- NOTES 1. APPLICABLE CRIMPING TOOL:
 JIS C9711 IZUMISEIKI CO., LTD. 9H-60 OR REC 150F.
- ⚠ WARNING 2. THE CONNECTOR IS NOT HOT PLUGGABLE. ⚠
3. REFER TO ASSEMBLY PROCEDURE MANUAL (ATAD-C0294). ⚠
4. REFER TO HANDLING PROCEDURE MANUAL (ATAD-C0307). ⚠
- ⚠ WARNING 5. KEEP YOUR FINGERS AND OTHER CONDUCTORS FROM COMING IN CONTACT WITH REF. No. ② IN ELECTRICALLY CHARGED CONDITIONS IN ORDER TO AVOID ELECTRICAL SHOCK AND SHORT-CIRCUIT. ⚠
- ⚠ WARNING 6. MAKE SURE THAT THE CONNECTOR IS INSERTED TO THE END AND LOCKED WHEN MATED. CONFIRM THAT THE CONNECTOR IS NOT UNINTENTIONALLY RELEASED BY PULLING THE CABLE WITH LIGHT FORCE TO PREVENT INCOMPLETE MATING CONDITION. ⚠
7. CRIMP TERMINALS AS SHOWN BELOW ARE ALSO APPLICABLE. ⚠
 NICHIFU CO., LTD. R 38-5. JST CO., LTD. 38-5.
- ATTENTIONS PRIOR TO USE :
- DIMENSIONS SHALL SATISFY THAT OF IN REF. No. 2, AND NO DEFORMATION OR CONTAMINATION IS OBSERVED.
 - CONTACT RESISTANCE MUST BE BELOW THE STANDARD VALUE.
 - USE ONLY TIN PLATING TERMINAL.
- ⚠ WARNING • EVALUATE PRIOR TO USE, AS TIN PLATING CONDITION COULD AFFECT THE PERFORMANCE.

PARTS NO. ②

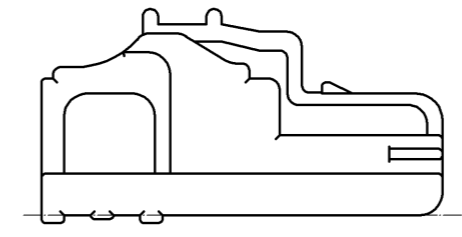
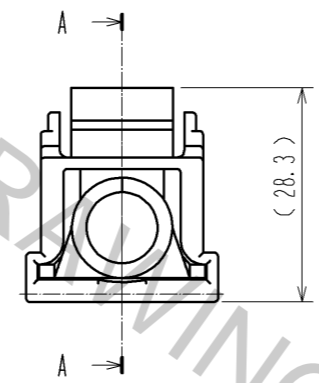
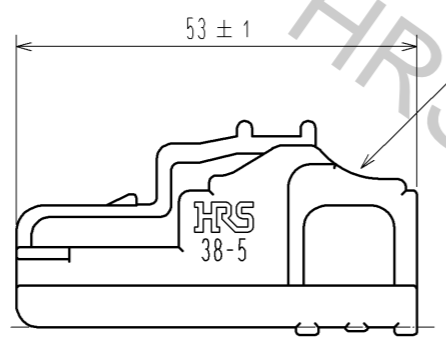
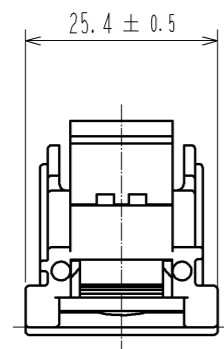
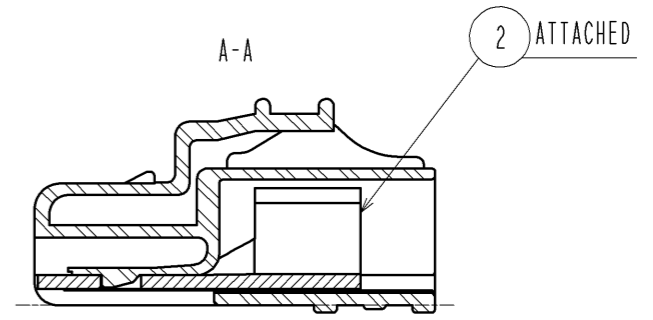
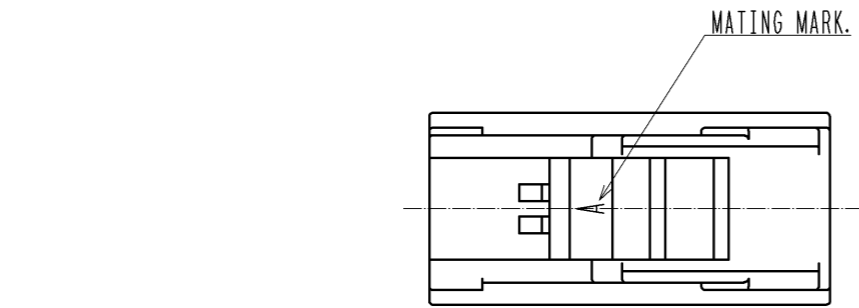
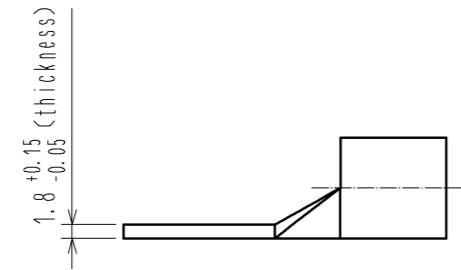
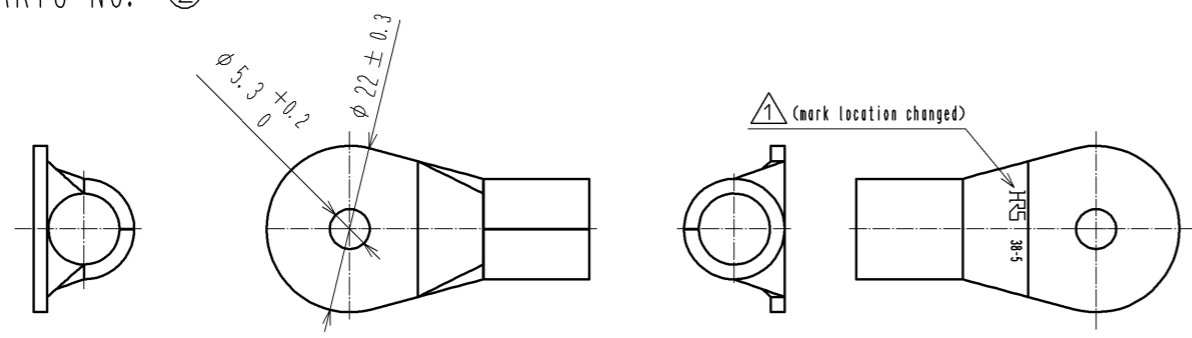

1	PBT	UL94V-0 (BLACK)	2	COPPER ALLOY	TIN PLATING 1 μm min.
NO.	MATERIAL	FINISH . REMARKS	NO.	MATERIAL	FINISH . REMARKS
UNITS mm		SCALE 1 : 1	COUNT 1	DESCRIPTION OF REVISIONS DIS-C-003173	DESIGNED KN. IKEHARA
HIROSE ELECTRIC CO., LTD.		APPROVED : SU. OBARA 12.08.22	DESIGNED NO.	EDC3-117803-00	
		CHECKED : HY. KOBAYASHI 12.08.22	PART NO.	EF1-38P-1PCA	
		DESIGNED : HS. KAWASHIMA 12.08.22	CODE NO.	CL142-0002-6-00	
		DRAWN : KN. IKEHARA 12.08.06		1/1	