

ISS.	AMEND	DATE
1	ISSUED	28/07/2011
2	NOTE 3 ADDED	06/10/2011
3	LAYOUT O/LINE ADDED	14/03/2012
4	NOTE 4 WAS FCR681465P	30/06/2014

PC LAYOUT
(COMPONENT SIDE
-SOCKET OMITTED
FOR CLARITY)

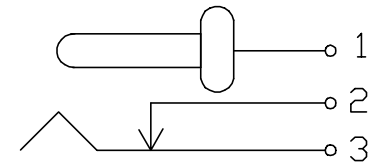

SCHMATIC

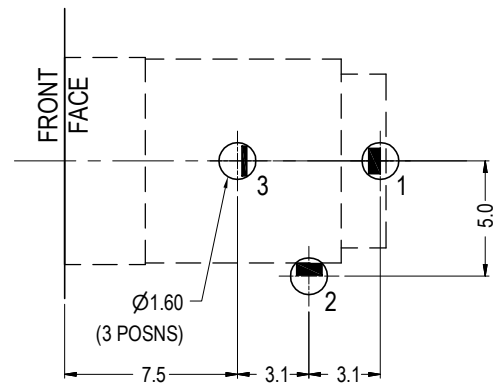
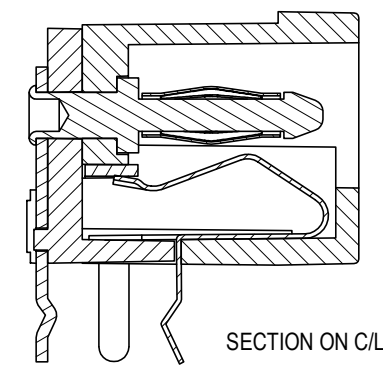
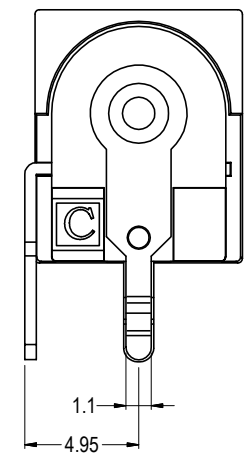
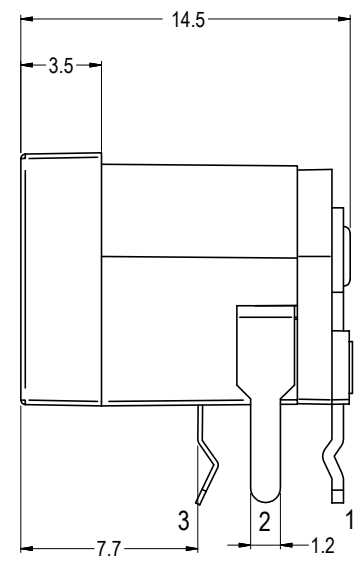
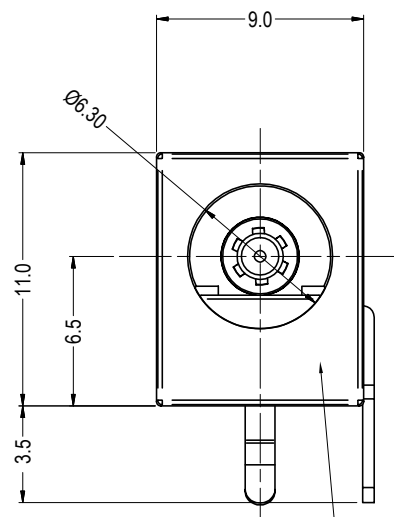

ALTERNATIVE
LOGO POSITION (FCR)

NOTES:-

- SUITABLE FOR USE WITH Ø2.1mm OR Ø2.5mm DC PLUG.
- RATED: 5A / 12V DC.
LIFE: 5,000 INSERTIONS MINIMUM.
INSULATION RESISTANCE BETWEEN ANY OPEN CONTACT
>100MW @ 500V DC.
- HOUSING MATERIAL: PBT 30% GF TO UL94 V-0 (3.2mm)
(CHANG CHUN PLASTIC PBT4830)
- FC681465P REPLACES FCR681465P

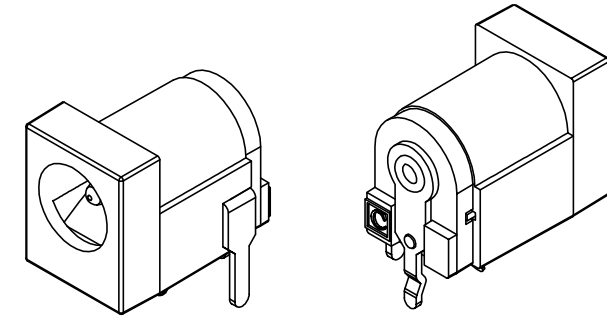

RoHS
COMPLIANT

TOLERANCE
NO DEC. PLACE ±
1 DEC. PLACE ±
2 DEC. PLACE ±
HOLE Ø ±
ANGLES ±
UNLESS
OTHERWISE STATED

Cliff Electronic Components Ltd.

DIMENSIONS IN MILLIMETERS UNLESS OTHERWISE STATED. WORK TO DIMENSIONS. REMOVE ALL BURRS. IF IN DOUBT ASK.

3rd ANGLE PROJECTION:

DO NOT SCALE

76 Holmehorpe Avenue, Holmehorpe Industrial Estate,
Redhill, Surrey, RH1 2PF, England, UK
Tel: 01737-771375 Fax: 01737-766012 Website: www.cliffuk.co.uk

MATERIAL: PBT / BRASS / PhBrz / BeCu

TITLE: DC10LP SOCKET (PCB MOUNT)

THE CONTENTS OF THIS DOCUMENT MUST NOT BE COPIED OR DISCLOSED TO A 3rd PARTY WITHOUT WRITTEN PERMISSION OF CLIFF UK. © 2011

FINISH: AS MOULDED / SILVER PLATED TAGS

DRAWN: NJB

DRWG. No. **FC681465P**

FORM: A4DRWGH

APPROVED: DPJ