

Sep.1.2018 Copyright 2018 HIROSE ELECTRIC CO., LTD. All Rights Reserved.
 In case that the application demands a high level of reliability, such as automotive,
 please contact a company representative for further information.

| 1 | | 2 | | | 3 | | | 4 | | |
|-------|--------------------------|----|------|------|-------|--------------------------|----|------|------|--|
| COUNT | DESCRIPTION OF REVISIONS | BY | CHKD | DATE | COUNT | DESCRIPTION OF REVISIONS | BY | CHKD | DATE | |
| △ | | | | | △ | | | | | |
| △ | | | | | △ | | | | | |
| △ | | | | | △ | | | | | |

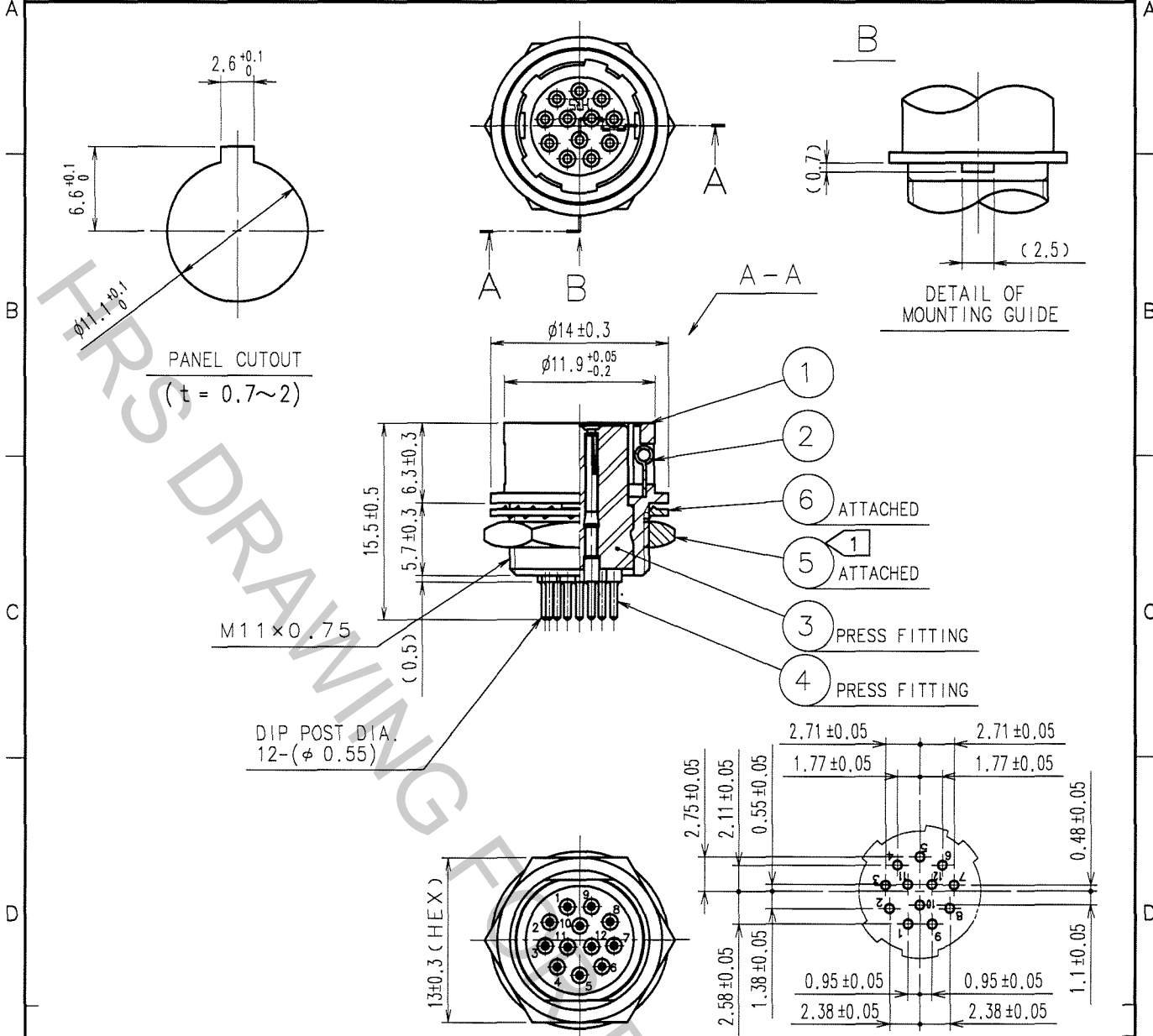

| NO. | MATERIAL | FINISH, REMARKS | NO. | MATERIAL | FINISH, REMARKS |
|-----|-----------------|----------------------------|-----|------------------|--|
| 3 | POLYAMIDE | (BLACK) UL94V-0 | 6 | PHOSPHOR BRONZE | NICKEL PLATING |
| 2 | STAINLESS STEEL | | 5 | BRASS | NICKEL PLATING |
| 1 | ZINC ALLOY | MATTE FINISH NICKEL PLATED | 4 | BERYLLIUM COPPER | GOLD PLATING 0.2 μ m min. NICKEL UNDER PLATING 2 μ m min. |

| | | | | | | |
|----------------------|--|---------------------|------------------------|----------------------|---------------------|----------|
| CODE NO. (OLD) CL | | DRAWN D. Matsume | DESIGNED D. Matsume | CHECKED E. Kurita | APPROVED M. Sato | RELEASED |
| | | 05.11.14 | 05.11.14 | 05.11.14 | 05.11.15 | |

| | | |
|-------------------------------|-------------------------------|-------------------------------|
| SCALE 2 : 1 UNITS mm | DRAWING NO. EDC4-009047-73 | PART NO. HR10-10R-12SA(73) |
| | HIROSE ELECTRIC CO., LTD. | CODE NO. CL110-0049-5-73 |

| |
|----|
| TO |
| R |
| |
| |