

Oct.1.2018 Copyright 2018 HIROSE ELECTRIC CO., LTD. All Rights Reserved.
 In case that the application demands a high level of reliability, such as automotive,
 please contact a company representative for further information.

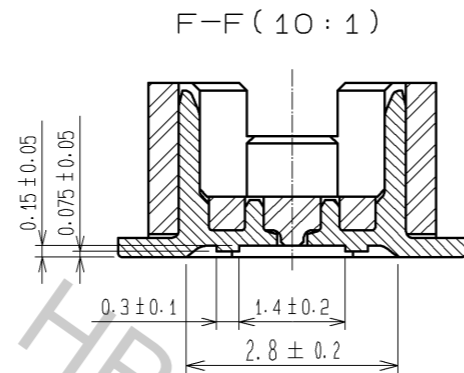

CODE No.	CONTACT	A	B	C	D	E
CL537-0826-8-81	10	4.7	2.0	2.8	3.2	2.8
CL537-0921-9-81	14	5.7	3.0	3.8	4.2	3.8
CL537-0828-3-81	20	7.2	4.5	5.3	5.7	5.3
CL537-0830-5-81	30	9.7	7.0	7.8	8.2	7.8
CL537-0837-4-81	32	10.2	7.5	8.3	8.7	8.3
CL537-0831-8-81	36	11.2	8.5	9.3	9.7	9.3
CL537-0832-0-81	40	12.2	9.5	10.3	10.7	10.3
CL537-0834-6-81	50	14.7	12.0	12.8	13.2	12.8
CL537-0836-1-81	60	17.2	14.5	15.3	15.7	15.3
CL537-0838-7-81	80	22.2	19.5	20.3	20.7	20.3

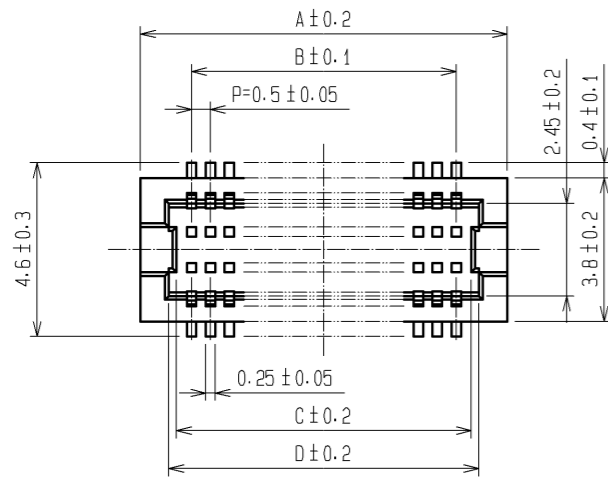
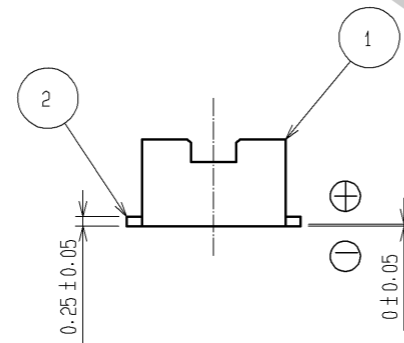
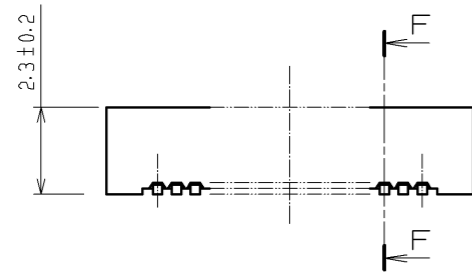

RECOMMEND METAL MASK PATTERN (10:1)

RECOMMENDED LAND PATTERN (10:1)

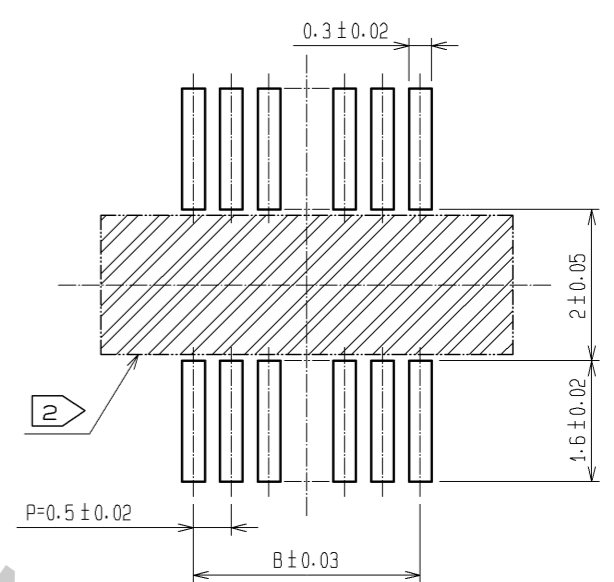
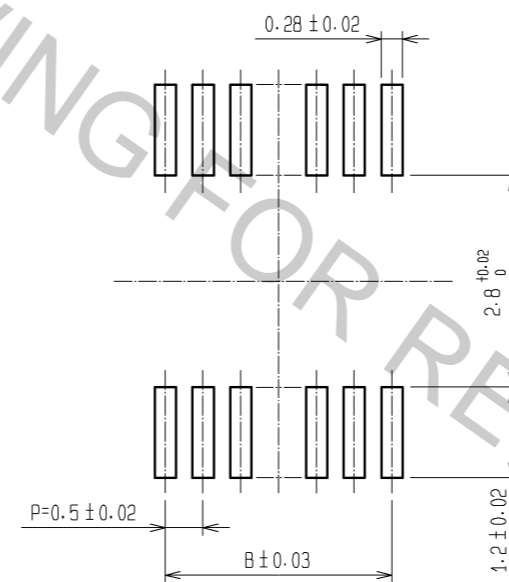

RECOMMENDED THICKNESS OF SOLDER PASTE : 120 μm

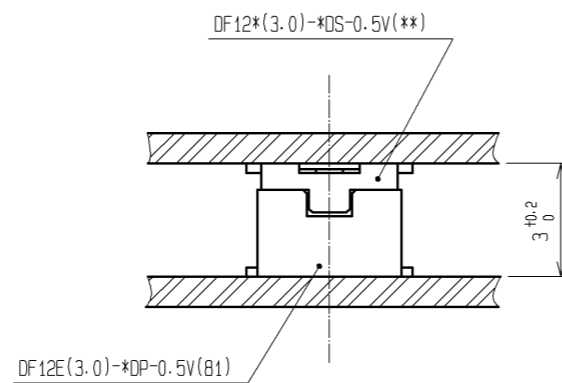
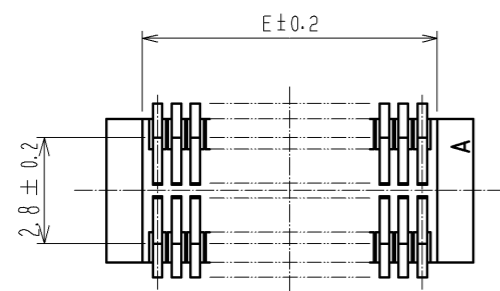

NOTES 1 LEAD CO-PLANARITY SHALL BE 0.08 mm MAX.
 2 IF THERE IS PATTERN ON PART, THERE IS A POSSIBILITY THAT IT WILL MAKE CONTACT WITH THE LEADS.

2	PHOSPHOR BRONZE	CONTACT AREA:GOLD PLATED 0.2μm min	6	PS	CLEAR (REINFORCEMENT COLLAR)			
		LEAD AREA:GOLD PLATED 0.015μm min	5	PS	BLACK (PLASTIC REEL)			
		OTHERS(UNDER PLATING):NICKEL PLATED 2μm min	4	POLYESTER	CLEAR (COVER TAPE)			
1	POLYAMIDE	UL94V-0, NATURAL (BEIGE)	3	PS	CLEAR (EMBOSSED CARRIER TAPE)			
NO.	MATERIAL	FINISH . REMARKS	NO.	MATERIAL	FINISH . REMARKS			
UNITS mm		SCALE 5 : 1	COUNT 	DESCRIPTION OF REVISIONS		DESIGNED	CHECKED	DATE
HRS HIROSE ELECTRIC CO., LTD.		APPROVED : KH. IKEDA	11. 12. 12	DRAWING NO. EDC3-160394-77				
		CHECED : TS. MIYAZAKI	11. 12. 12	PART NO. DF12E(3.0)-*DP-0.5V(81)				
		DESIGNED : YH. MICHIDA	11. 12. 12	CODE NO. CL537				
		DRAWN : KR. AJITO	11. 12. 09					

Oct.1.2018 Copyright 2018 HIROSE ELECTRIC CO., LTD. All Rights Reserved.
 In case that the application demands a high level of reliability, such as automotive,
 please contact a company representative for further information.

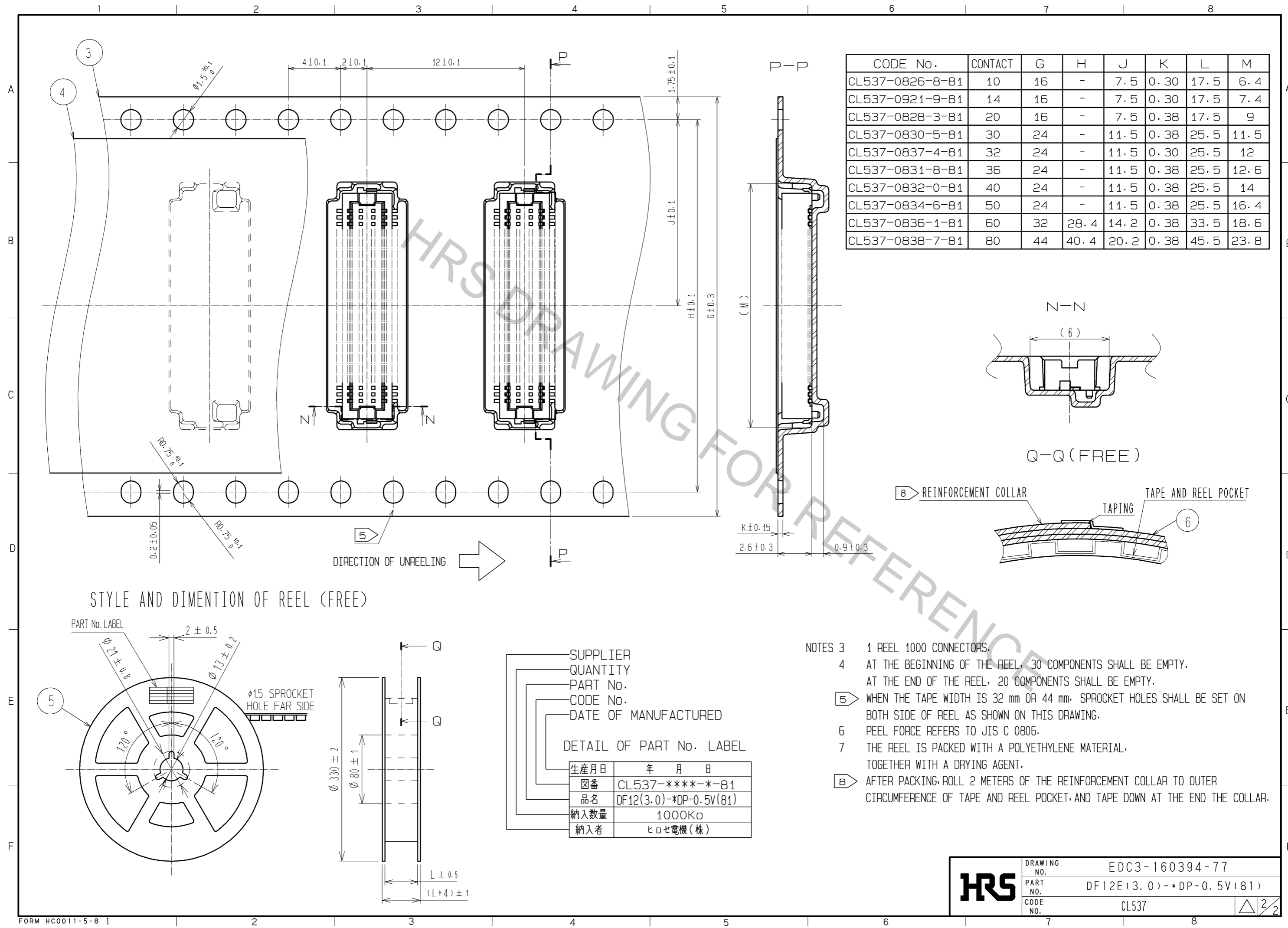

CODE No.	CONTACT	G	H	J	K	L	M
CL537-0826-8-81	10	16	-	7.5	0.30	17.5	6.4
CL537-0921-9-81	14	16	-	7.5	0.30	17.5	7.4
CL537-0828-3-81	20	16	-	7.5	0.38	17.5	9
CL537-0830-5-81	30	24	-	11.5	0.38	25.5	11.5
CL537-0837-4-81	32	24	-	11.5	0.30	25.5	12
CL537-0831-8-81	36	24	-	11.5	0.38	25.5	12.6
CL537-0832-0-81	40	24	-	11.5	0.38	25.5	14
CL537-0834-6-81	50	24	-	11.5	0.38	25.5	16.4
CL537-0836-1-81	60	32	28.4	14.2	0.38	33.5	18.6
CL537-0838-7-81	80	44	40.4	20.2	0.38	45.5	23.8

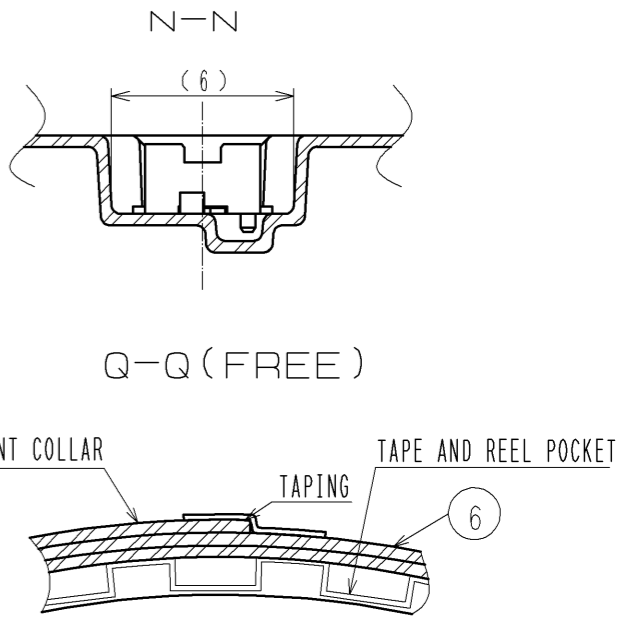

STYLE AND DIMENTION OF REEL (FREE)

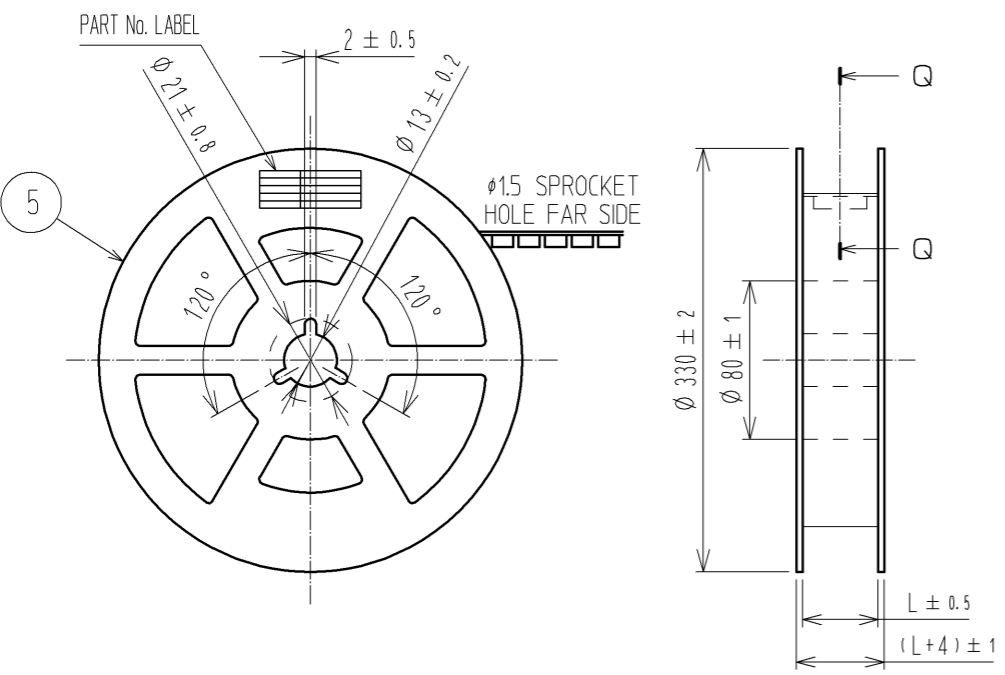

SUPPLIER
 QUANTITY
 PART No.
 CODE No.
 DATE OF MANUFACTURED

DETAIL OF PART No. LABEL

生産月日	年 月 日
図番	CL537-****-*-81
品名	DF12(3.0)-*DP-0.5V(81)
納入数量	1000K \square
納入者	ヒロセ電機(株)

- NOTES 3 1 REEL 1000 CONNECTORS.
 4 AT THE BEGINNING OF THE REEL, 30 COMPONENTS SHALL BE EMPTY.
 AT THE END OF THE REEL, 20 COMPONENTS SHALL BE EMPTY.
 5 WHEN THE TAPE WIDTH IS 32 mm OR 44 mm, SPROCKET HOLES SHALL BE SET ON BOTH SIDE OF REEL AS SHOWN ON THIS DRAWING.
 6 PEEL FORCE REFERS TO JIS C 0806.
 7 THE REEL IS PACKED WITH A POLYETHYLENE MATERIAL, TOGETHER WITH A DRYING AGENT.
 8 AFTER PACKING, ROLL 2 METERS OF THE REINFORCEMENT COLLAR TO OUTER CIRCUMFERENCE OF TAPE AND REEL POCKET, AND TAPE DOWN AT THE END THE COLLAR.

HRS	DRAWING NO.	EDC3-160394-77
	PART NO.	DF12E(3.0)-*DP-0.5V(81)
	CODE NO.	CL537